

**DIAMOND
PRODUCTS**

CONCRETE SAW

PARTS LIST

MODEL

CC1800XL

**ELECTRIC & HYDRAULIC
UNITS**

June 2011

Part #1801037

RECOMMENDED POWER CORD GAUGE

HORSE POWER	PHASE	VOLTS	AMPS	50 Ft. CORD	100 Ft. CORD	150 Ft. CORD	200 Ft. CORD
5hp	1ph	230v	23A	#10	#8	#6	#4
5hp	3ph	230v	12A	#14	#12	#10	#8
5hp	3ph	460v	6A	#14	#14	#12	#10
7.5hp	1ph	230v	33A	#8	#8	#6	#4
10hp	3ph	230v	24A	#10	#8	#6	#4
10hp	3ph	460v	12A	#14	#12	#10	#8
20hp	3ph	230v	52A	#6	#6	#4	#2
20hp	3ph	460v	26A	#10	#8	#6	#4
25hp	3ph	230v	58A	#6	#6	#4	#2
25hp	3ph	460v	29A	#10	#8	#6	#4
30hp	3ph	230v	74A	#6	#4	#2	#1
30hp	3ph	460v	37A	#8	#6	#4	#2
40hp	3ph	460v	48A	#8	#6	#4	#2
50hp	3ph	460v	62A	#4	#4	#2	#0

CAUTION: Use of a wire gauge that is too small will cause loss of power or overheating and will damage the electric motor.

TABLE OF CONTENTS

DESCRIPTION	PAGE
Common Parts	4 - 7
Axle Assemblies	8 - 9
Transmission Assembly	10 - 11
Blade Shaft Assembly, Electric Units	12 - 14
Blade Shaft Assembly, Hydraulic Units	15
Pointer Assemblies	16 - 17
230 Volt, 7.5HP, Single Phase	18 - 22
230Volt, 10HP, 3Phase	24 - 28
460 Volt, 10HP, 3Phase	30 - 34
575 Volt, 10HP, 3Phase	36 - 40
Weight Bar Option	41
Hydraulic Motor, 1.16 CI	42 - 43
Hydraulic Motor, 1.55 CI	44 - 45
Hydraulic Motor, 1.94 CI	46 - 47
Blade Guard Assemblies	48 - 50
Brake Option	51
Warranty	Rear Cover

REFERENCE: SERVICE FILTERS & BELTS

2500037	Blade Shaft Belt (4) for Electric/Hydraulic Motors	(Gates #3VX375)
2500635	Transmission Belt for Electric Motors	(Gates #4L-420)
2500632	Transmission Belt for Hydraulic Motors	(Gates #4L-410)

6048960: CC1800 XL, COMMON PARTS

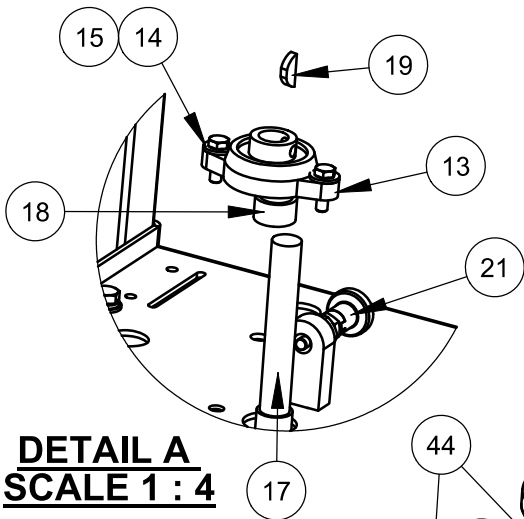

DETAIL A
SCALE 1 : 4

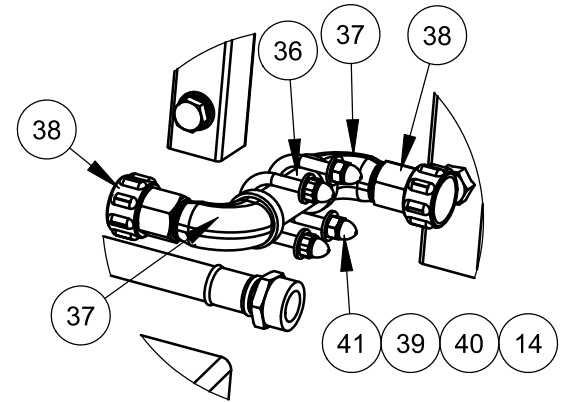

DETAIL E
SCALE 1 : 4

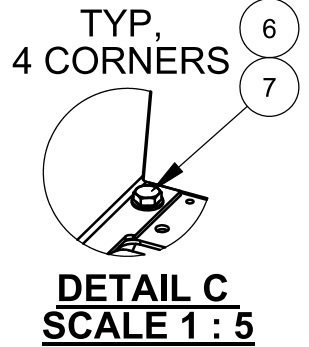
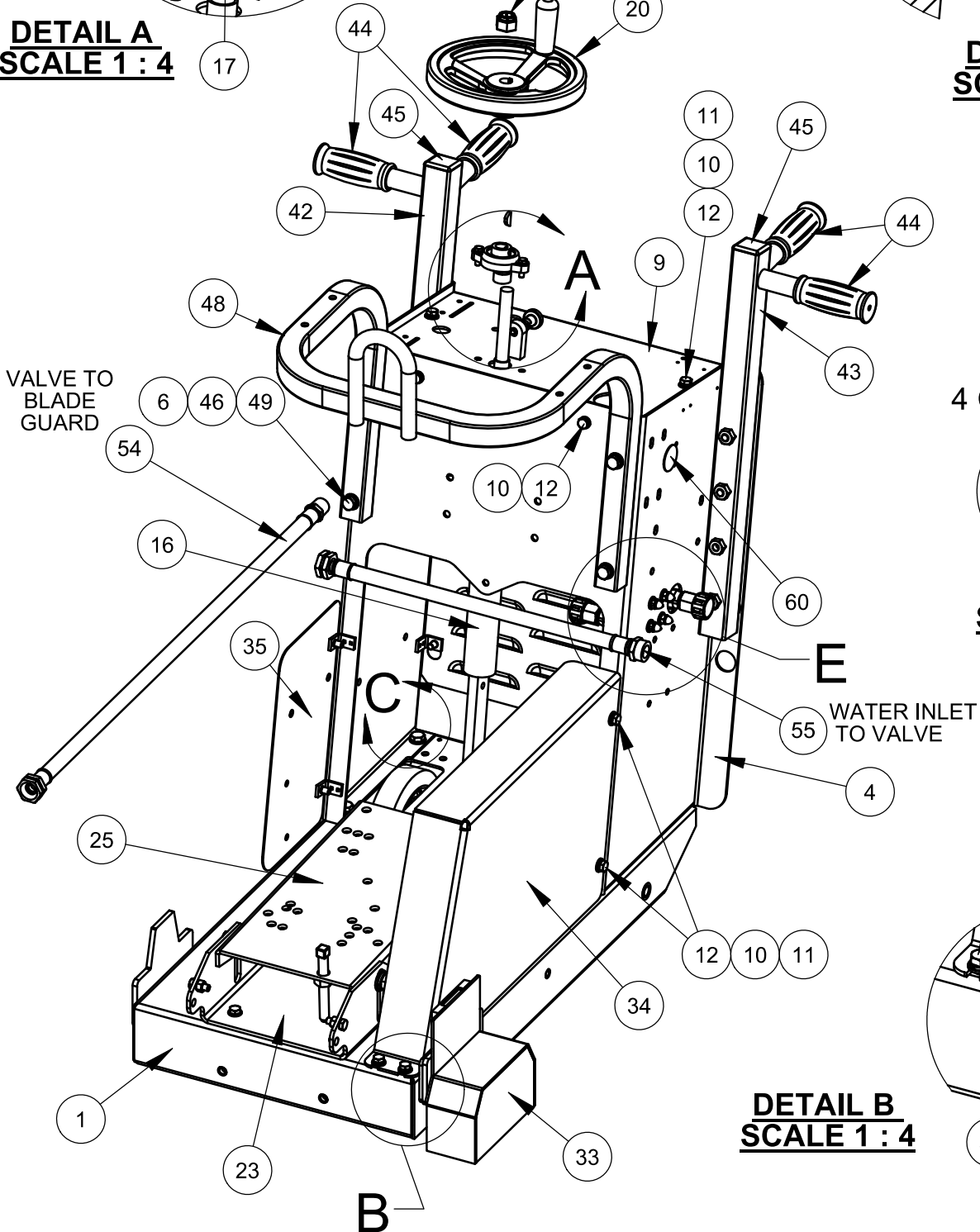

DETAIL C
SCALE 1 : 5

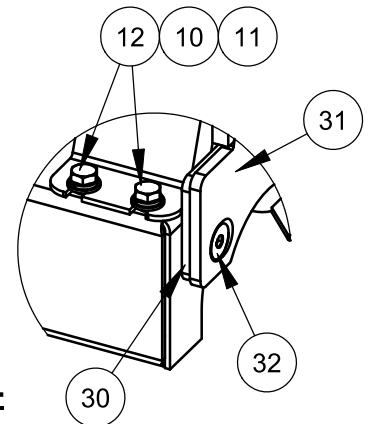

DETAIL B
SCALE 1 : 4

6048960: CC1800 XL, COMMON PARTS

ITEM NO.	PART NUMBER	QTY.	DESCRIPTION
1	6048859	1	Frame Weldment, CC1800
2	6048956	1	Axle Assembly
3	6048104	1	Axle Assembly
4	6048331	1	Frame Upright Weldment
5	2900056	2	Set Screw, Soc. Hd., 1/4-20 x 1/4"
6	2900014	16	Flat Washer, 3/8" SAE
7	2900314	4	Cap Screw, Hex Hd., M10-1.5 x 20mm
8	2900304	4	Lock Nut, M10-1.5 Nylon Insert
9	6049044	1	Control Panel Weldment
10	2900031	16	Lock Washer, 5/16" Split
11	2900022	26	Flat Washer, 5/16" SAE
12	2900329	24	Cap Screw, Hex Hd., M8-1.25 x 20mm
13	2500807	1	Bearing, 5/8", Two Bolt Flange
14	2900009	6	Flat Washer, 1/4" SAE
15	2900310	2	Cap Screw, Hex Hd., M6-1.0 x 20mm
16	6047928	1	Adjustment Shaft W/Grease Fitting
17	6047929	1	Adjustment Screw
18	6047931	1	Spacer Tube 7/8 x 1/2
19	2900352	1	Woodruff Key, 5/32 x 3/4, #506
20	2500800	1	Handwheel, 8"
21	2400138	1	Indexing Plunger 1/2-13
22	2900355	1	Lock Nut, 5/8-18, Flex Top
23	6048060	1	Engine Base Mount
24	2900303	8	Lock Nut, M8-1.25 Nylon Insert
25	6048059	1	Engine Base Weldment
26	2900058	4	Flat Washer, 1/2" SAE
27	2900084	4	Lock Washer, 1/2" Split
28	2900330	4	Cap Screw, Hex Hd., M12-1.75 x 30mm
29	2900332	1	Setscrew, Sq. Hd., M12 x 100mm
30	6048915	1	Tapered Guard Mount Spacer
31	6048908	2	Tapered Guard Mount
32	2900744	4	Capscrew, Flat Hd., M10 x 25mm
33	6048906	1	Shaft Guard
34	6048329	1	Belt Guard
35	6048328	1	Slurry Shield
36	3201737	1	1/2" NPT x 3", Nipple
37	3200013	4	Street Elbow, 1/2" NPT
38	3200022	2	Fitting, 1/2" F. Pipe to 3/4" F. Garden
39	2900241	2	U-Bolt, 3/4" Pipe
40	2900125	4	Hex Nut, 1/4-20
41	2900827	4	Acorn Nut, High Crown, 1/4-20
42	6048601	1	Handlebar
43	6048602	1	Handlebar
44	2500636	4	Handle Grip
45	2503925	2	Cap, 1-1/2" Sq. Tube
46	2900321	8	Lock Washer, M10 Split
47	2901348	4	Cap Screw, Hex Hd., M10 x 55mm
48	6048632	1	Lift Bar Assembly
49	2900318	4	Cap Screw, Hex Hd., M10-1.5 x 50mm
50	3200026	1	Water Valve, 1/2" FPT
51	2900038	2	Lock Washer, #10 Split
52	2900021	2	Machine Screw, Pan Hd., #10-24 x 3/8"
53	3200155	1	Fitting, 1/2" M. Pipe to 3/4" M. Garden
54	2500256	1	Wrench Head
55	6048919	1	Hose Assy., 1/2 x 31.6", Water
56	6048918	1	Hose Assy., 1/2 x 18-1/2", Water
57	2900307	1	Wing Screw, M6 x 16mm
58	6048063	1	Rear Cover Screen
59	2500204	1	Plug, 1/2" Hole
60	2501146	1	Plug, 1-1/4" Hole

6048960: CC1800 XL, COMMON PARTS

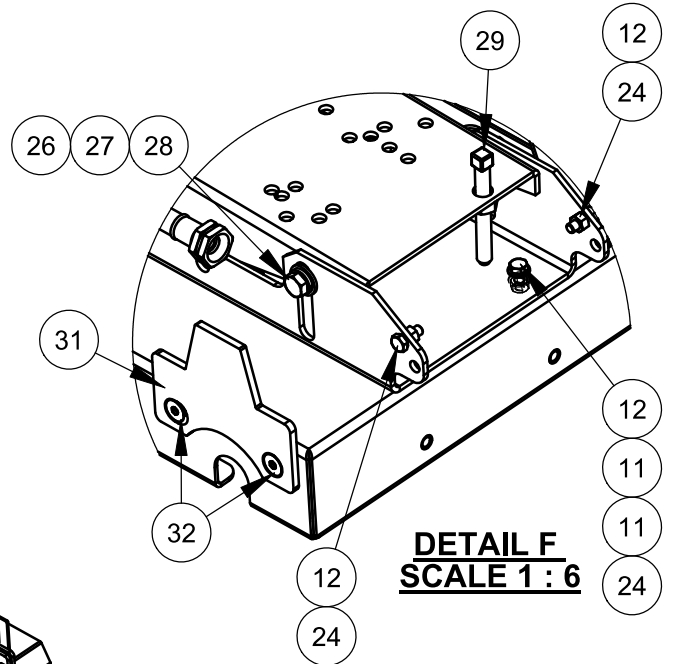
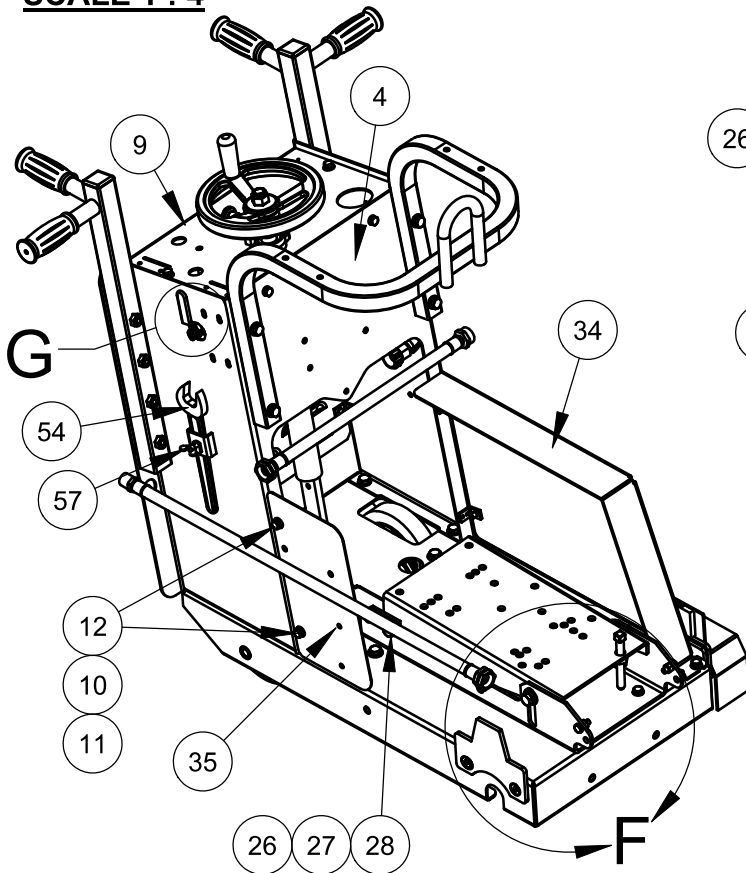
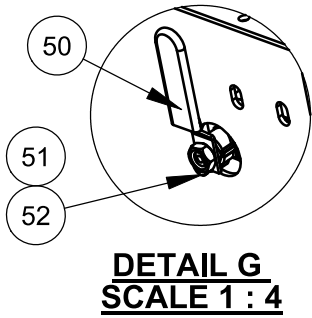
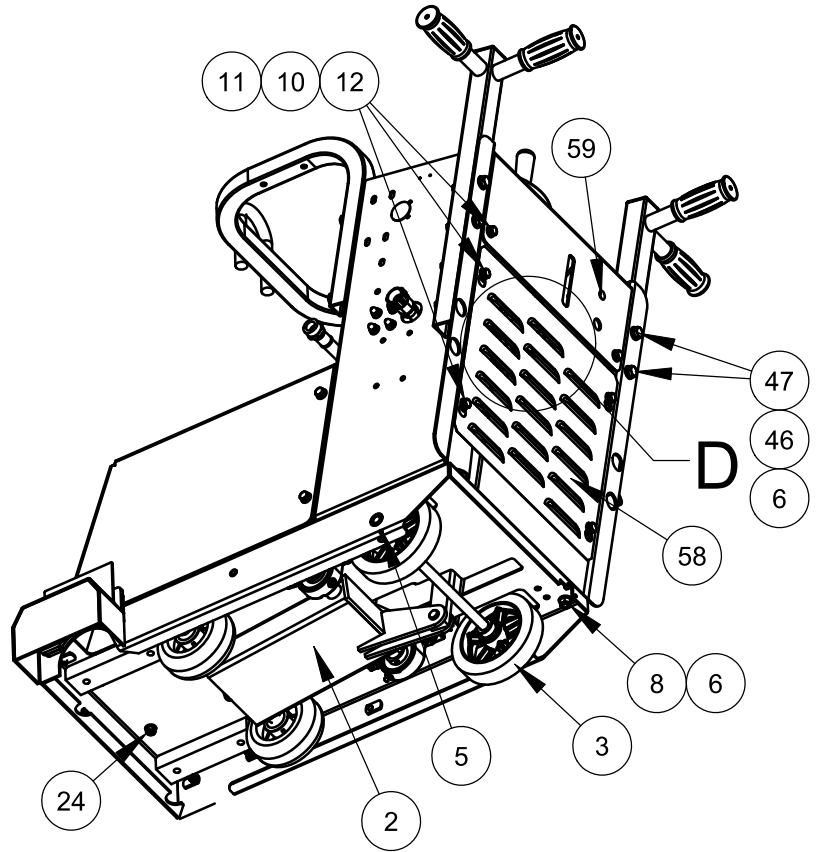
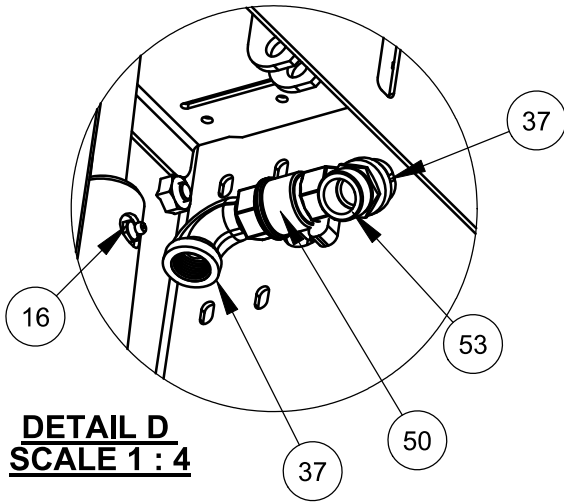

6048960: CC1800 XL, COMMON PARTS

ITEM NO.	PART NUMBER	QTY.	DESCRIPTION
1	6048859	1	Frame Weldment, CC1800
2	6048956	1	Axle Assembly
3	6048104	1	Axle Assembly
4	6048331	1	Frame Upright Weldment
5	2900056	2	Set Screw, Soc. Hd., 1/4-20 x 1/4"
6	2900014	16	Flat Washer, 3/8" SAE
7	2900314	4	Cap Screw, Hex Hd., M10-1.5 x 20mm
8	2900304	4	Lock Nut, M10-1.5 Nylon Insert
9	6049044	1	Control Panel Weldment
10	2900031	16	Lock Washer, 5/16" Split
11	2900022	26	Flat Washer, 5/16" SAE
12	2900329	24	Cap Screw, Hex Hd., M8-1.25 x 20mm
13	2500807	1	Bearing, 5/8", Two Bolt Flange
14	2900009	6	Flat Washer, 1/4" SAE
15	2900310	2	Cap Screw, Hex Hd., M6-1.0 x 20mm
16	6047928	1	Adjustment Shaft W/Grease Fitting
17	6047929	1	Adjustment Screw
18	6047931	1	Spacer Tube 7/8 x 1/2
19	2900352	1	Woodruff Key, 5/32 x 3/4, #506
20	2500800	1	Handwheel, 8"
21	2400138	1	Indexing Plunger 1/2-13
22	2900355	1	Lock Nut, 5/8-18, Flex Top
23	6048060	1	Engine Base Mount
24	2900303	8	Lock Nut, M8-1.25 Nylon Insert
25	6048059	1	Engine Base Weldment
26	2900058	4	Flat Washer, 1/2" SAE
27	2900084	4	Lock Washer, 1/2" Split
28	2900330	4	Cap Screw, Hex Hd., M12-1.75 x 30mm
29	2900332	1	Setscrew, Sq. Hd., M12 x 100mm
30	6048915	1	Tapered Guard Mount Spacer
31	6048908	2	Tapered Guard Mount
32	2900744	4	Capscrew, Flat Hd., M10 x 25mm
33	6048906	1	Shaft Guard
34	6048329	1	Belt Guard
35	6048328	1	Slurry Shield
36	3201737	1	1/2" NPT x 3", Nipple
37	3200013	4	Street Elbow, 1/2" NPT
38	3200022	2	Fitting, 1/2" F. Pipe to 3/4" F. Garden
39	2900241	2	U-Bolt, 3/4" Pipe
40	2900125	4	Hex Nut, 1/4-20
41	2900827	4	Acorn Nut, High Crown, 1/4-20
42	6048601	1	Handlebar
43	6048602	1	Handlebar
44	2500636	4	Handle Grip
45	2503925	2	Cap, 1-1/2" Sq. Tube
46	2900321	8	Lock Washer, M10 Split
47	2901348	4	Cap Screw, Hex Hd., M10 x 55mm
48	6048632	1	Lift Bar Assembly
49	2900318	4	Cap Screw, Hex Hd., M10-1.5 x 50mm
50	3200026	1	Water Valve, 1/2" FPT
51	2900038	2	Lock Washer, #10 Split
52	2900021	2	Machine Screw, Pan Hd., #10-24 x 3/8"
53	3200155	1	Fitting, 1/2" M. Pipe to 3/4" M. Garden
54	2500256	1	Wrench Head
55	6048919	1	Hose Assy., 1/2 x 31.6", Water
56	6048918	1	Hose Assy., 1/2 x 18-1/2", Water
57	2900307	1	Wing Screw, M6 x 16mm
58	6048063	1	Rear Cover Screen
59	2500204	1	Plug, 1/2" Hole
60	2501146	1	Plug, 1-1/4" Hole

Front Axle Assembly 6048956

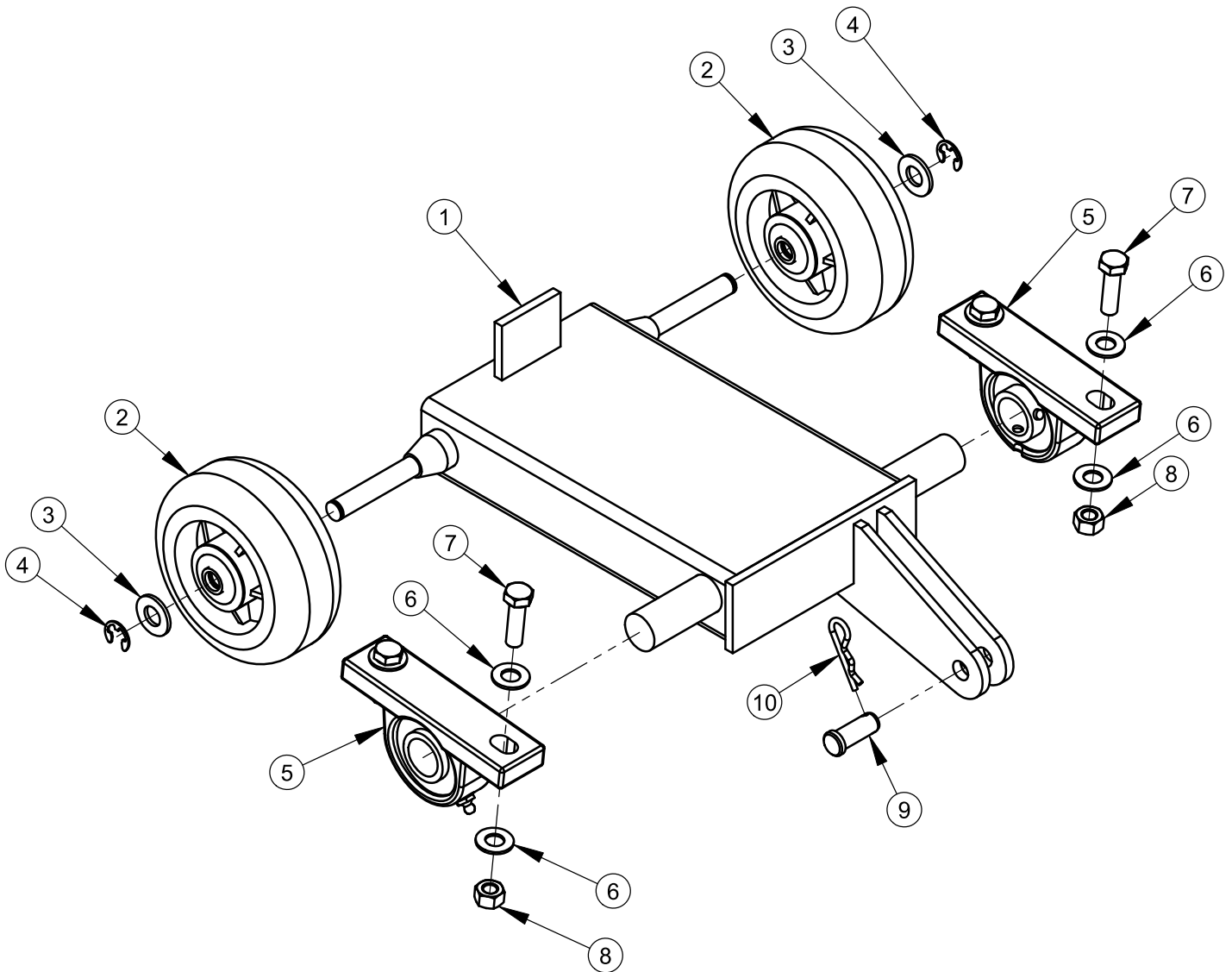

ITEM	PART NO.	QTY.	DESCRIPTION
1	6048635	1	Axle Weldment
2	2502194	2	Wheel
3	2900058	2	Flat Washer, 1/2" SAE
4	2503700	2	Retaining Ring, 1/2" External E-Type
5	2500013	2	Bearing, 1" Pillowblock
6	2900956	8	Flat Washer, 7/16" SAE
7	2900315	4	Cap Screw, Hex Hd., M10-1.5 x 35mm
8	2900304	4	Lock Nut, M10-1.5 Nylon Insert
9	2900266	1	Clevis Pin, 1/2 x 1-1/4"
10	2900276	1	Hairpin Cotter, 1/8" x 1/2" to 3/4"

Rear Axle Assembly 6048104

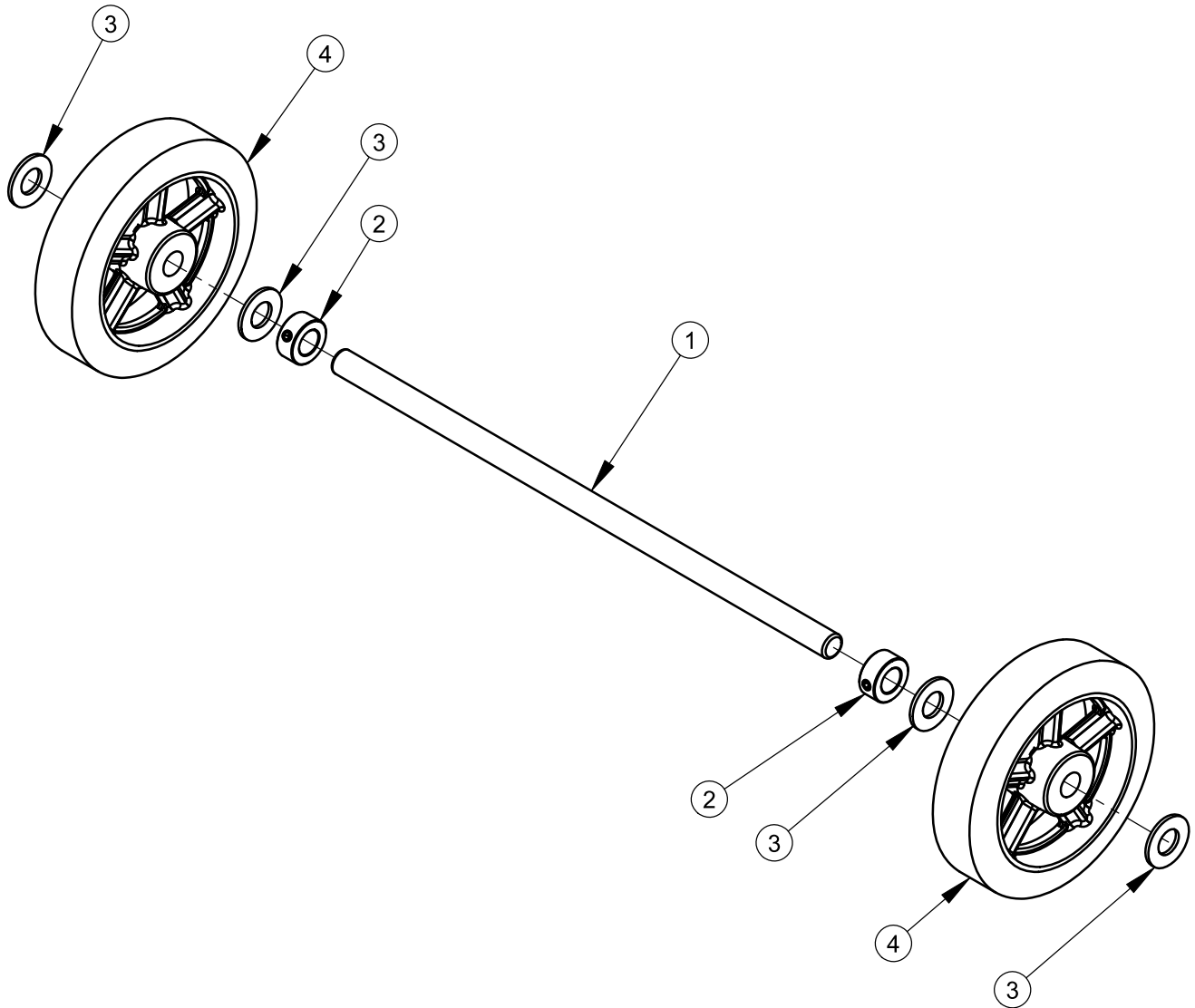

ITEM	PART NO.	QTY.	DESCRIPTION
1	6048105	1	Rear Axle
2	2500008	2	Set Collar, 5/8" with Set Screw
3	2900002	4	Flat Washer, 5/8" SAE
4	2500003	2	Wheel 6" x 1-1/2" x 5/8"

Transmission Assembly

#6048108

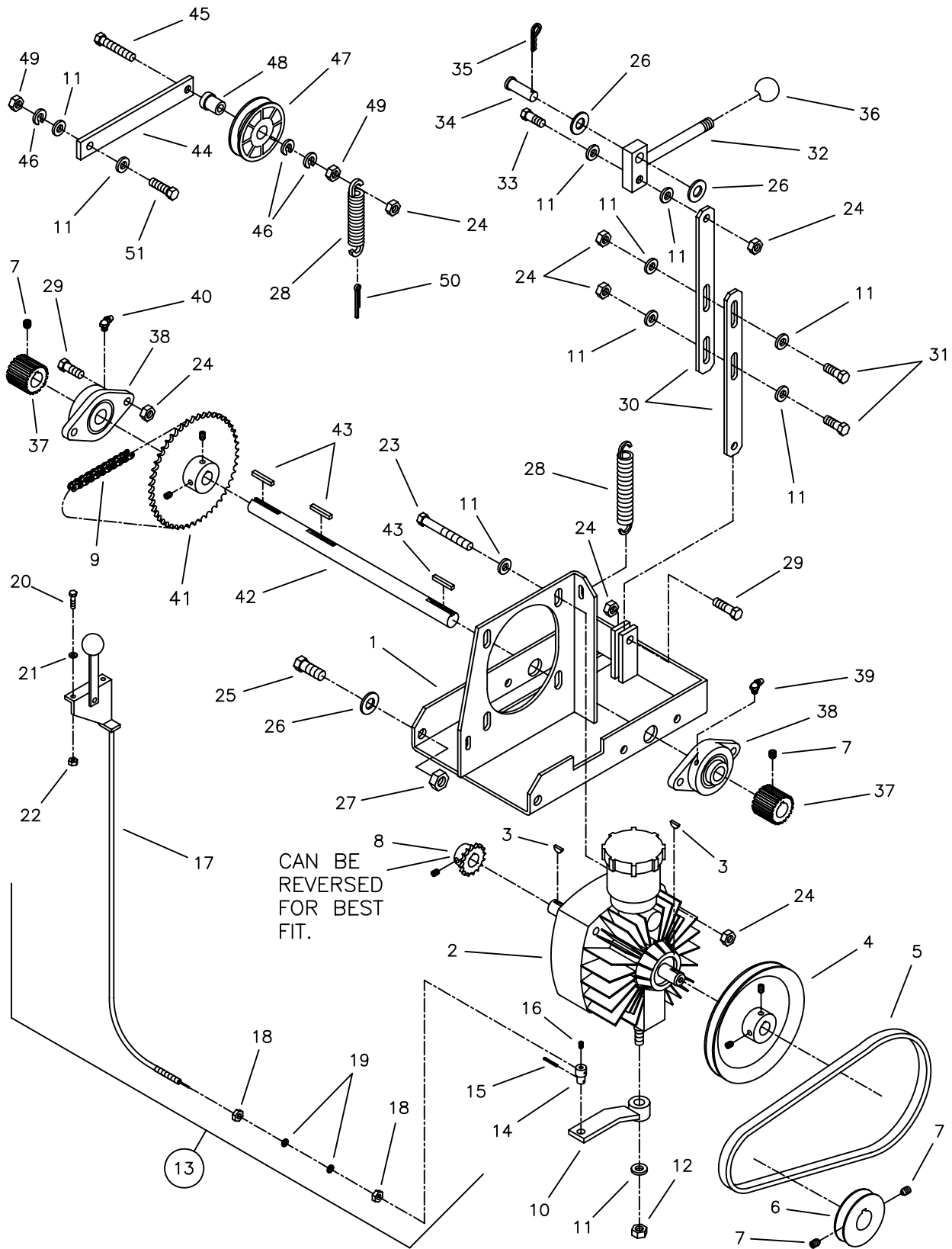

6048108: CC1800XL, Transmission
(Includes All Except Items #5 and #6)

ITEM	PART NO.	QTY	DESCRIPTION
1	6048066	1	Transmission Platform Weldment
2	2600015	1	Transmission
	2700523	1	(Oil Reservoir Only)
3	2900068	2	Woodruff Key #404, 1/8" Wide x 1/2" Dia.
4	2500016	1	Pulley, 6" Dia. with Setscrews
5	2500632	1	V-Belt, 4L-410 (16BV, 20BV, 20H)
	2500635	1	V-Belt, 4L-420 (7.5E, 10E)
	2500033	1	V-Belt, 4L-430 (13BV, 13H)
6	6048196	1	Accessory Drive Pulley, 1" Bore (13BV, 13H, 16BV, 20BV)
	6048195	1	Accessory Drive Pulley, 1-1/8" Bore (20H Only)
7	2900036	4	Setscrew, Soc. Hd., 5/16"-18 x 1/4"
8	2500017	1	Sprocket, 12 Teeth with Setscrew
9	6048232	1	#35 Chain, 63 Pitch
10	6048211	1	Shift Lever
11	2900014	13	Flat Washer, 3/8" SAE
12	2900018	1	Lock Nut, 3/8"-16 Nylon
13	6048106	1	Transmission Speed Control Assembly (Includes #14 - #22)
14	6048212	1	Pivot Pin
15	2900034	1	Cotter Pin, 3/32" x 3/4"
16	2900059	1	Setscrew, Soc. Hd., #10-32 x 1/4"
17	2500076	1	Transmission Speed Control
18	2900186	2	Hex Nut, 1/4"-28
19	2900009	2	Flat Washer, 1/4" SAE
20	2900309	2	Capscrew, Hex Hd., M5 x 20mm
21	2900016	2	Flat Washer, #10 USS
22	2900301	2	Lock Nut, M5 Nylon
23	2900319	4	Capscrew, Hex Hd., M10 x 80mm
24	2900304	13	Lock Nut, M10 Nylon
25	2900330	2	Capscrew, Hex Hd., M12 x 30mm
26	2900058	4	Flat Washer, 1/2" SAE
27	2900327	2	Lock Nut, M12 Nylon
28	2500070	2	Spring, 3/4" Dia. x 4"
29	2900223	5	Capscrew, Hex Hd., M10 x 30mm
30	6048065	2	Linkage
31	2900333	2	Capscrew, Hex Hd., M10 x 25mm
32	6048057	1	Engagement Lever
33	2900315	1	Capscrew, Hex Hd., M10 x 35mm
34	2900277	1	Clevis Pin, 1/2" Dia. x 1-1/2"
35	2900276	1	Hair Pin Cotter, 1/2"
36	2400007	1	Knob, 1/2"-20
37	6048235	2	Wheel Drive
38	2500011	2	Flange Block Bearing, 3/4"
39	2900061	1	Grease Fitting, 1/4"-28 x 90°
40	2900184	1	Grease Fitting, 1/4"-28 x 45°
41	2500018	1	Sprocket, 48 Teeth with Setscrews
42	6048228	1	Drive Shaft
43	6010170	3	Key, 3/16" Sq. x 1"
44	6048085	1	Idler Arm
45	2900337	1	Capscrew, Hex Hd., M10 x 50mm (Full Thread)
46	2900321	3	Lock Washer, M10 Split
47	2500074	1	Idler Pulley With Bushing #48
48	2500246	1	Bushing Only
49	2900325	2	Hex Nut, M10
50	2900055	1	Cotter Pin, 3/16" x 1"
51	2900317	1	Capscrew, Hex Hd., M10 x 45mm

6040503 Blade Shaft Assembly
230/460 Volt Electric Saws

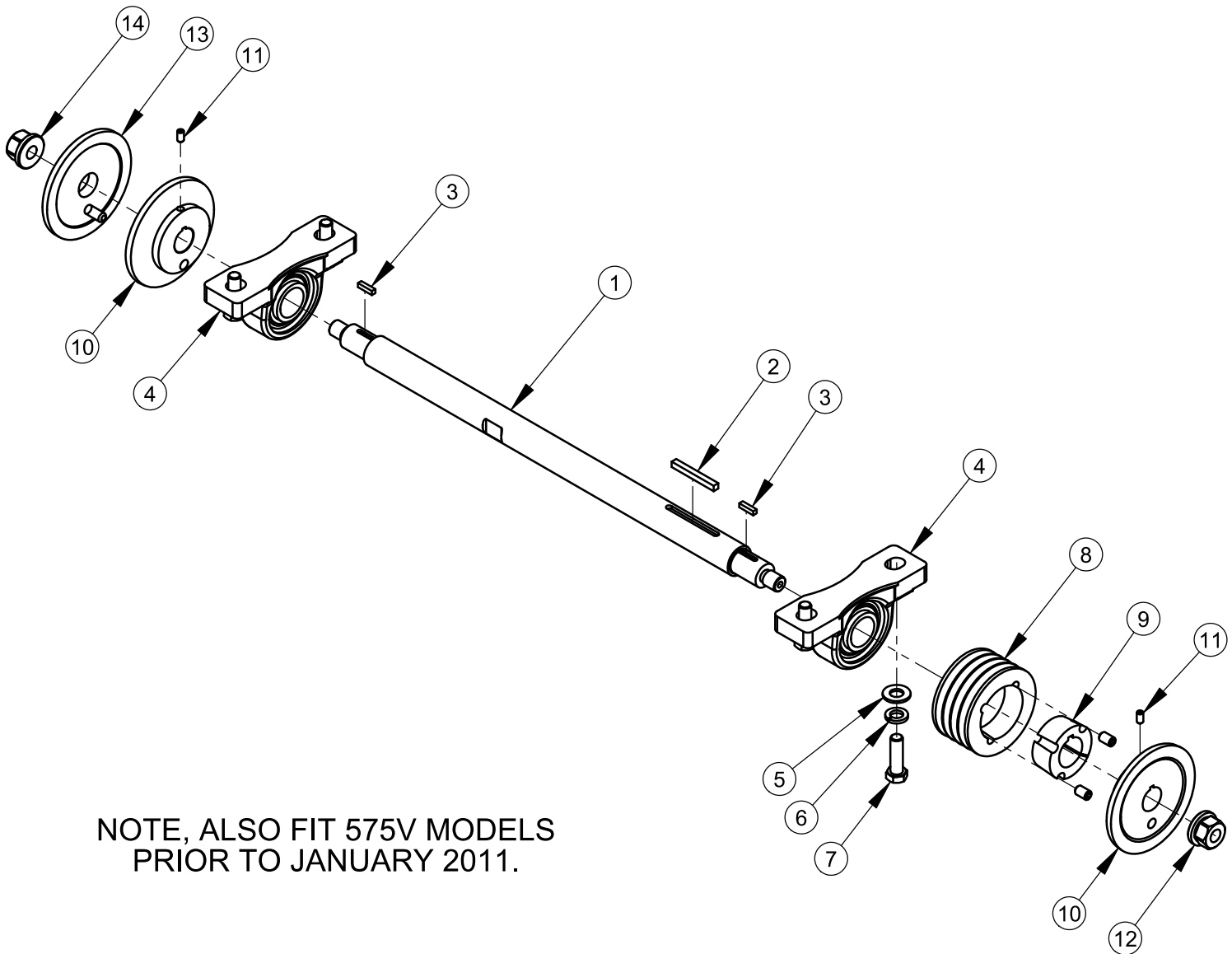

NOTE, ALSO FIT 575V MODELS
 PRIOR TO JANUARY 2011.

ITEM	PART NO.	QTY.	DESCRIPTION
1	6048865	1	Blade Shaft
2	6048134	1	Key, 1/4" Sq. x 2-1/4"
3	6048018	2	Key, 3/16" Sq. x 3/4"
4	2500365	2	Pillow Block Bearing, 1-1/4"
5	2900058	4	Flat Washer, 1/2" SAE
6	2900084	4	Lock Washer, 1/2" Split
7	2900331	4	Cap Screw, Hex Hd., M12-1.75 x 40mm
8	2500621	1	Sheave, 3V-3.65-4 Groove (1610)
9	2500337	1	Taper Bushing, 1-1/4"
10	6048008	2	Inner Flange 4-1/2"
11	2900076	2	Set Screw, Soc. Hd., 1/4-20 x 1/2"
12	2900065	1	Flange Nut, 5/8-11 R.H.
13	6048009	1	Outer Flange, 4-1/2" w/ Pin
14	2900066	1	Flange Nut, 5/8-11, L. Hand

6040524 BLADE SHAFT ASSEMBLY, 575V ELECTRIC UNITS.

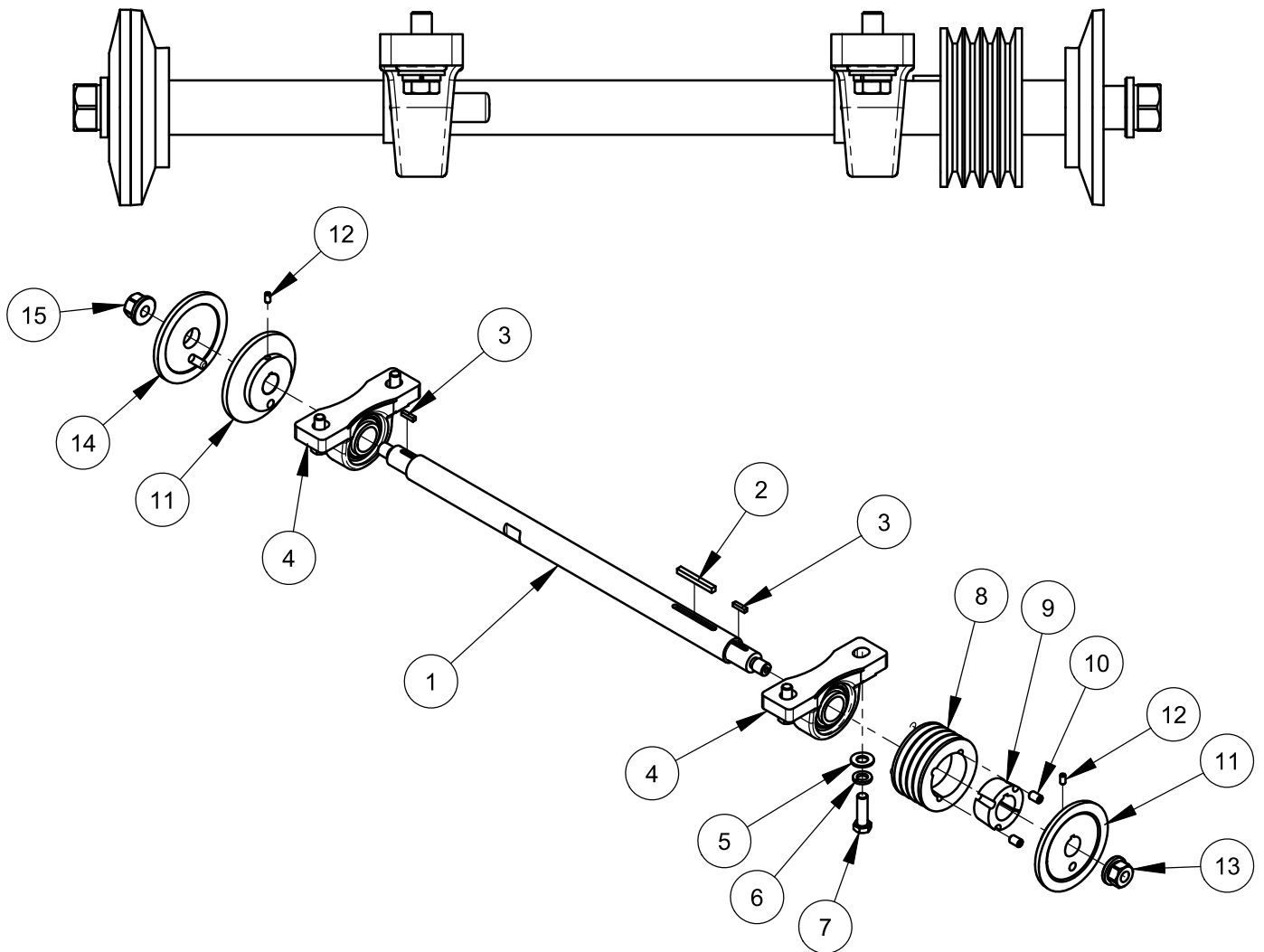

ITEM	PART NO.	QTY.	DESCRIPTION
1	6048880	1	Blade Shaft
2	6048134	1	Key, 1/4" Sq. x 2-1/4"
3	6048018	2	Key, 3/16" Sq. x 3/4"
4	2500365	2	Pillow Block Bearing, 1-1/4"
5	2900058	4	Flat Washer, 1/2" SAE
6	2900084	4	Lock Washer, 1/2" Split
7	2900331	4	Cap Screw, Hex Hd., M12 x 40mm
8	2500621	1	Sheave, 3V-3.65-4 Groove (1610)
9	2500337	1	Taper Bushing, 1-1/4"
10	2900484	2	Set Screw, Soc. Hd., 3/8-16 x 5/8"
11	6048008	2	Inner Flange 4-1/2"
12	2900076	2	Set Screw, Soc. Hd., 1/4-20 x 1/2"
13	2900065	1	Flange Nut, 5/8-11 R.H.
14	6048009	1	Outer Flange, 4-1/2" w/ Pin
15	2900066	1	Flange Nut, 5/8-11, L. Hand

6040518 BLADE SHAFT ASSEMBLY, 24" BLADE

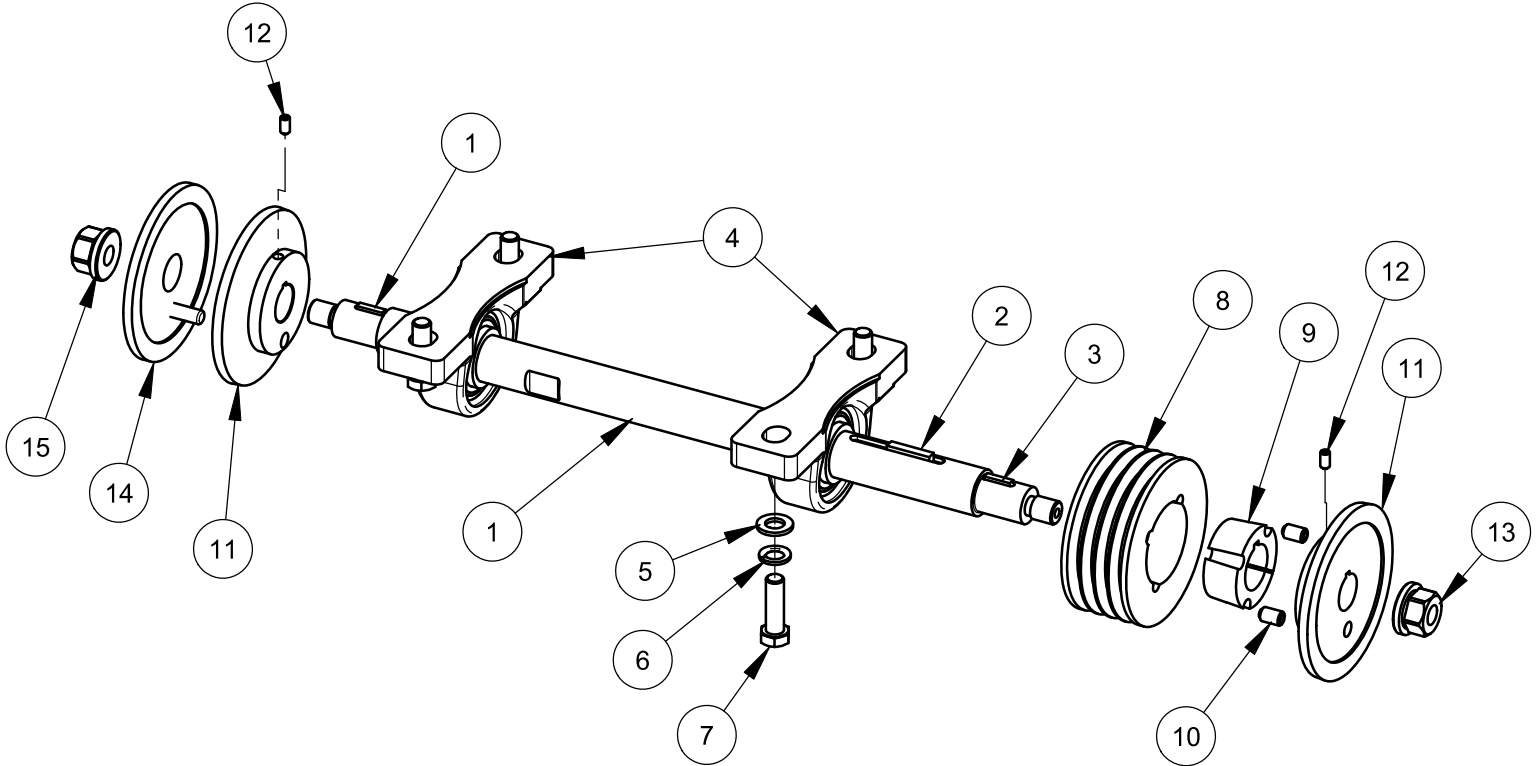
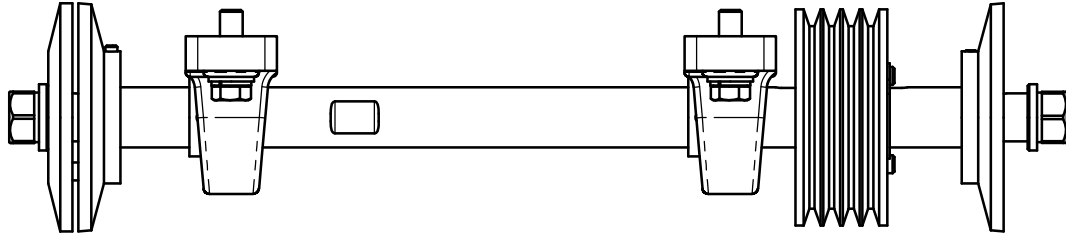

ITEM	PART NO.	QTY.	DESCRIPTION
1	6048866	1	Blade Shaft
2	6010169	1	Key, 1/4" Sq. x 1-1/4"
3	6048018	2	Key, 3/16" Sq. x 3/4"
4	2500365	2	Pillow Block Bearing, 1-1/4"
5	2901357	4	Flat Washer, M12
6	2900699	4	Lock Washer, M12 Split
7	2900331	4	Cap Screw, Hex Hd., M12 x 40mm
8	2506315	1	Sheave, 3V-4.50-4 Groove
9	2500337	1	Taper Bushing, 1-1/4"
10	2900484	2	Set Screw, Soc. Hd., 3/8-16 x 5/8"
11	6048238	2	Inner Flange, 4-3/4"
12	2900076	2	Set Screw, Soc. Hd., 1/4-20 x 1/2"
13	2900065	1	Flange Nut, 5/8-11 R.H.
14	6048240	1	Outer Flange, 4-3/4", W/Pin
15	2900066	1	Flange Nut, 5/8-11, L. Hand

Blade Shaft Assembly
Hydraulic Units
6040502

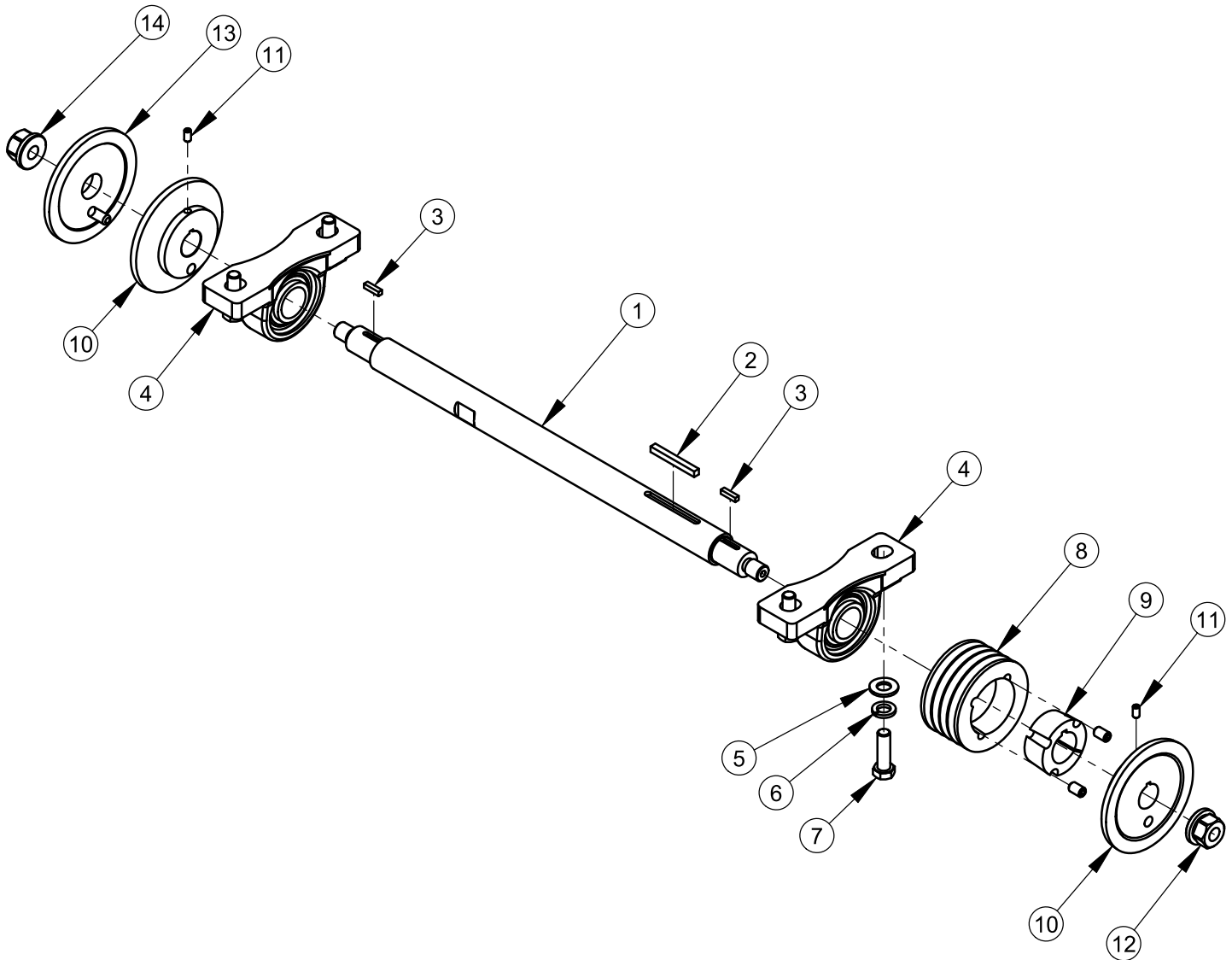

ITEM	PART NO.	QTY.	DESCRIPTION
1	6048866	1	Blade Shaft
2	6048134	1	Key, 1/4" Sq. x 2-1/4"
3	6048018	2	Key, 3/16" Sq. x 3/4"
4	2500365	2	Pillow Block Bearing, 1-1/4"
5	2900058	4	Flat Washer, 1/2" SAE
6	2900084	4	Lock Washer, 1/2" Split
7	2900331	4	Cap Screw, Hex Hd., M12-1.75 x 40mm
8	2500621	1	Sheave, 3V-3.65-4 Groove (1610)
9	2500337	1	Taper Bushing, 1-1/4"
10	6048008	2	Inner Flange 4-1/2"
11	2900076	2	Set Screw, Soc. Hd., 1/4-20 x 1/2"
12	2900065	1	Flange Nut, 5/8-11 R.H.
13	6048009	1	Outer Flange, 4-1/2" w/ Pin
14	2900066	1	Flange Nut, 5/8-11, L. Hand

6047994 Pointer Assembly, Electric Units

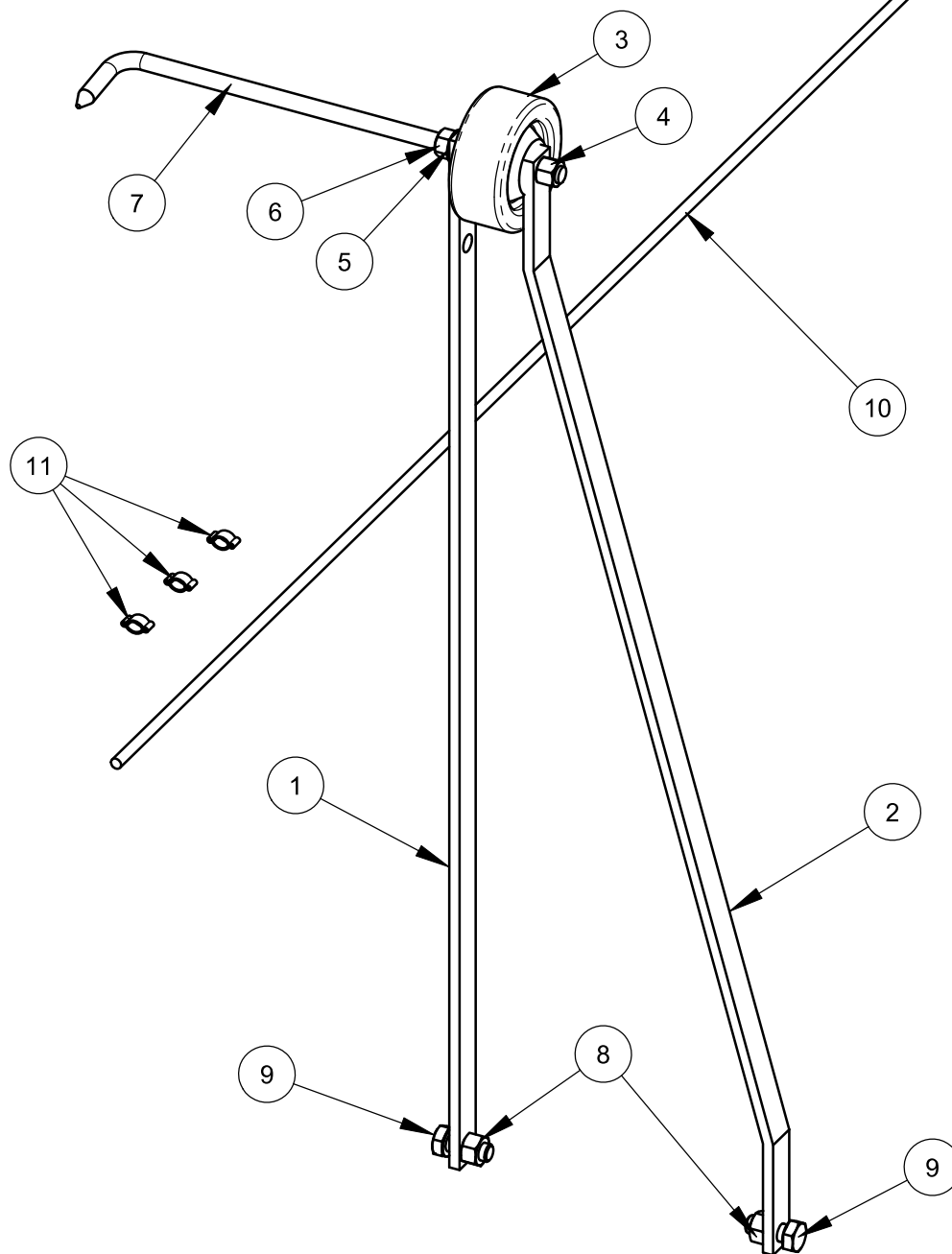

ITEM	PART NO.	Default/QTY.	DESCRIPTION
1	6048069	1	Pointer Bar - Straight
2	6048070	1	Pointer Bar - Offset
3	2500624	1	Wheel, 3"
4	2900018	1	Lock Nut, 3/8-16 Nylon
5	2900321	1	Lock Washer, M10 Split
6	2900033	1	Hex Nut, 3/8-16
7	2900743	1	Pointer Rod, 11"
8	2900304	2	Lock Nut, M10-1.5 Nylon Insert
9	2900333	2	Cap Screw, Hex Hd., M10 x 25mm
10	6048078	1	Rope, 1/4 x 78"
11	3200221	3	Pinch Clamp, Two Ear

6048080 Pointer Assembly, Gas & Hydraulic Units

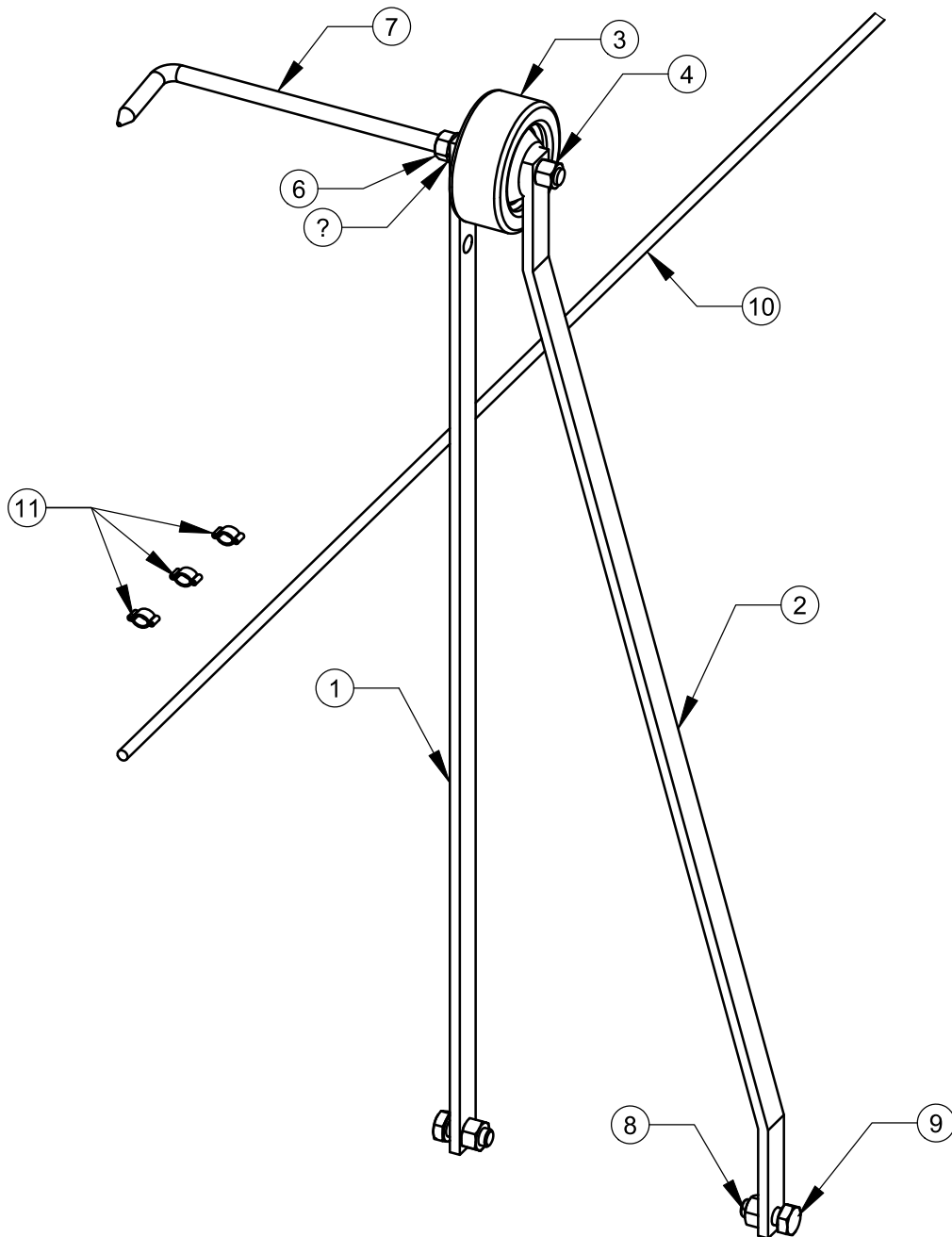

ITEM NO.	PART NUMBER	Defau lt/QT Y.	DESCRIPTION
1	6048069	1	Pointer Bar - Straight
2	6048070	1	Pointer Bar - Offset
3	2500624	1	Wheel, 3"
4	2900018	1	Lock Nut, 3/8-16 Nylon
5	2900006	1	Lock Washer, 3/8" Split
6	2900033	1	Hex Nut, 3/8-16
7	2900032	1	Pointer Rod
8	2900304	2	Lock Nut, M10-1.5 Nylon Insert
9	2900333	2	Cap Screw, Hex Hd., M10 x 25mm
10	6048078	1	Rope, 1/4 x 78"
11	3200221	3	Pinch Clamp, Two Ear

6048971 CC1800 XL ELECTRIC MOTOR OPTION, 7-1/2 HP, 230V, 1-PHASE

DETAIL B
SCALE 1 : 2

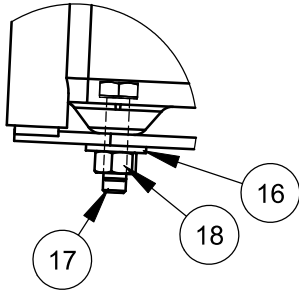

DETAIL A
SCALE 1 : 2

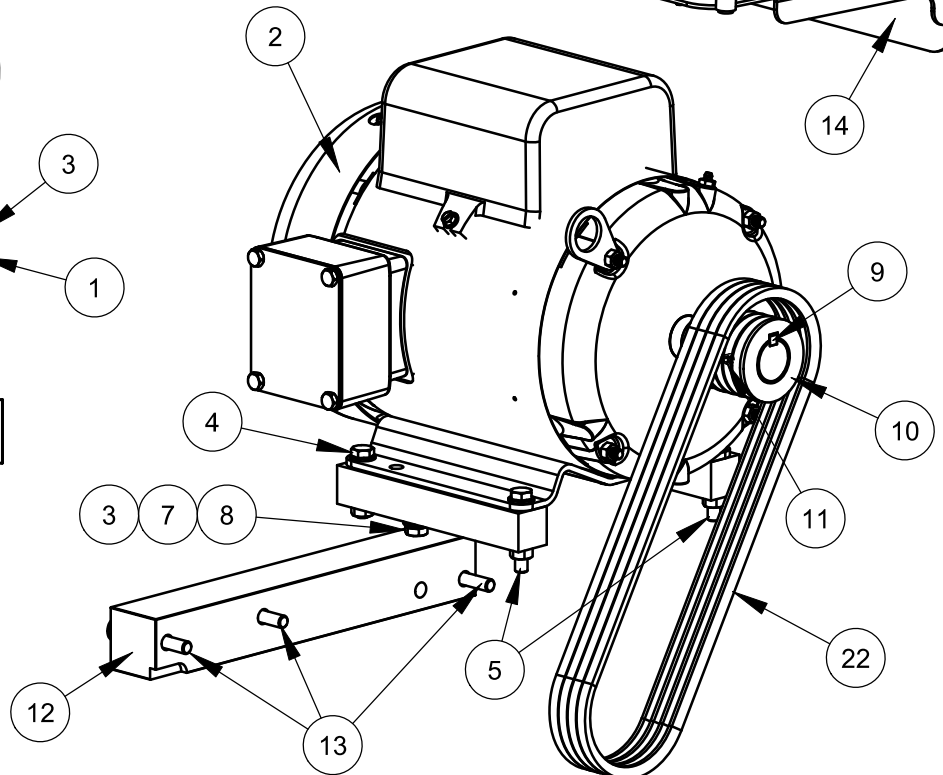
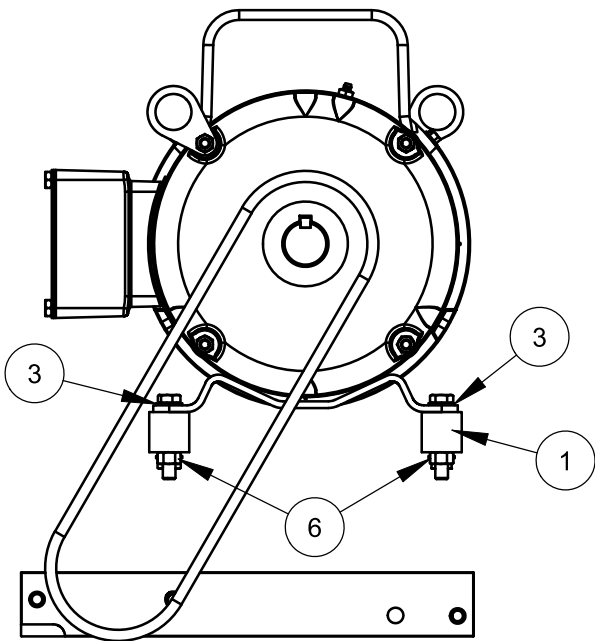
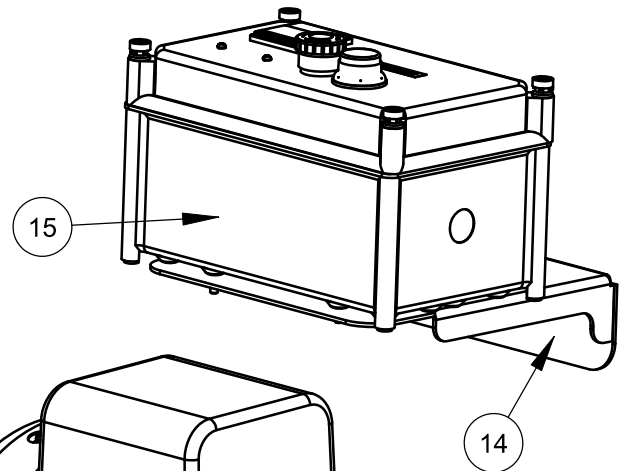
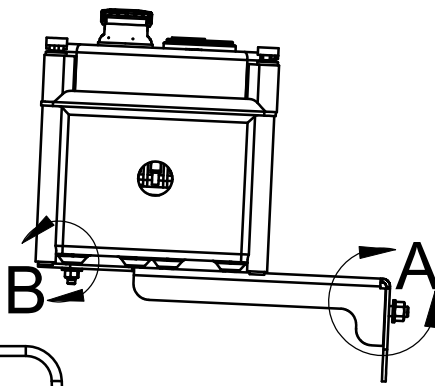
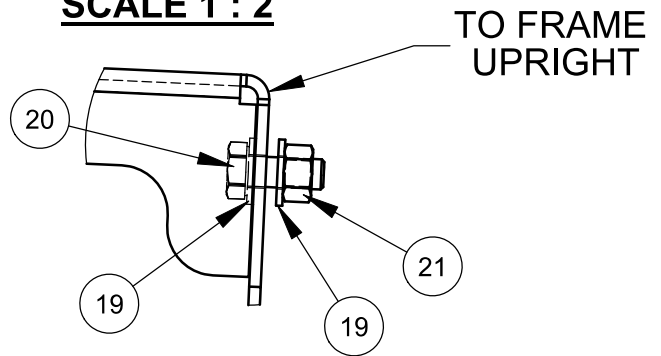

6048971 CC1800 XL ELECTRIC MOTOR OPTION, 7-1/2 HP, 230V, 1-PHASE

ITEM NO.	PART NUMBER	QTY.	DESCRIPTION
1	6048100	2	Motor Spacer
2	2600186	1	Motor, 7.5hp 1 Phase Baldor
3	2900014	6	Flat Washer, 3/8" SAE
4	2900318	2	Cap Screw, Hex Hd., M10 x 50mm
5	2900338	2	Cap Screw, Hex Hd., M10 x 60mm
6	2900304	4	Lock Nut, M10 Nylon
7	2900321	2	Lock Washer, M10 Split
8	2900333	2	Cap Screw, Hex Hd., M10 x 25mm
9	6048046	1	Key, 5/16" Sq. x 1-1/2"
10	6048049	1	Sheave 2.65-3V-4 Groove/4L-1 Groove x 1-7/16"
11	2900036	1	Set Screw, Soc. Hd., 5/16-18 x 1/4"
12	6048319	1	Blade Guard Spacer
13	2900908	3	Cap Screw, Flat Hd. Soc., M10 x 80mm
14	6048326	1	Bracket, Electric Box
15	6048355	1	Starter Box Assembly, 7.5HP -1PH, 230V
16	2900009	8	Flat Washer, 1/4" SAE
17	2900311	4	Cap Screw, Hex Hd., M6 x 25
18	2900302	4	Lock Nut, M6 Nylon
19	2900022	4	Flat Washer, 5/16" SAE
20	2900329	2	Capscrew, Hex Hd., M8 x 1.25 x 20mm
21	2900303	2	Lock Nut, M8 Nylon
22	2500037	4	V-Belt, 3VX375

Starter Box Assembly, 7.5 HP, 1-Phase, 230V #6048355

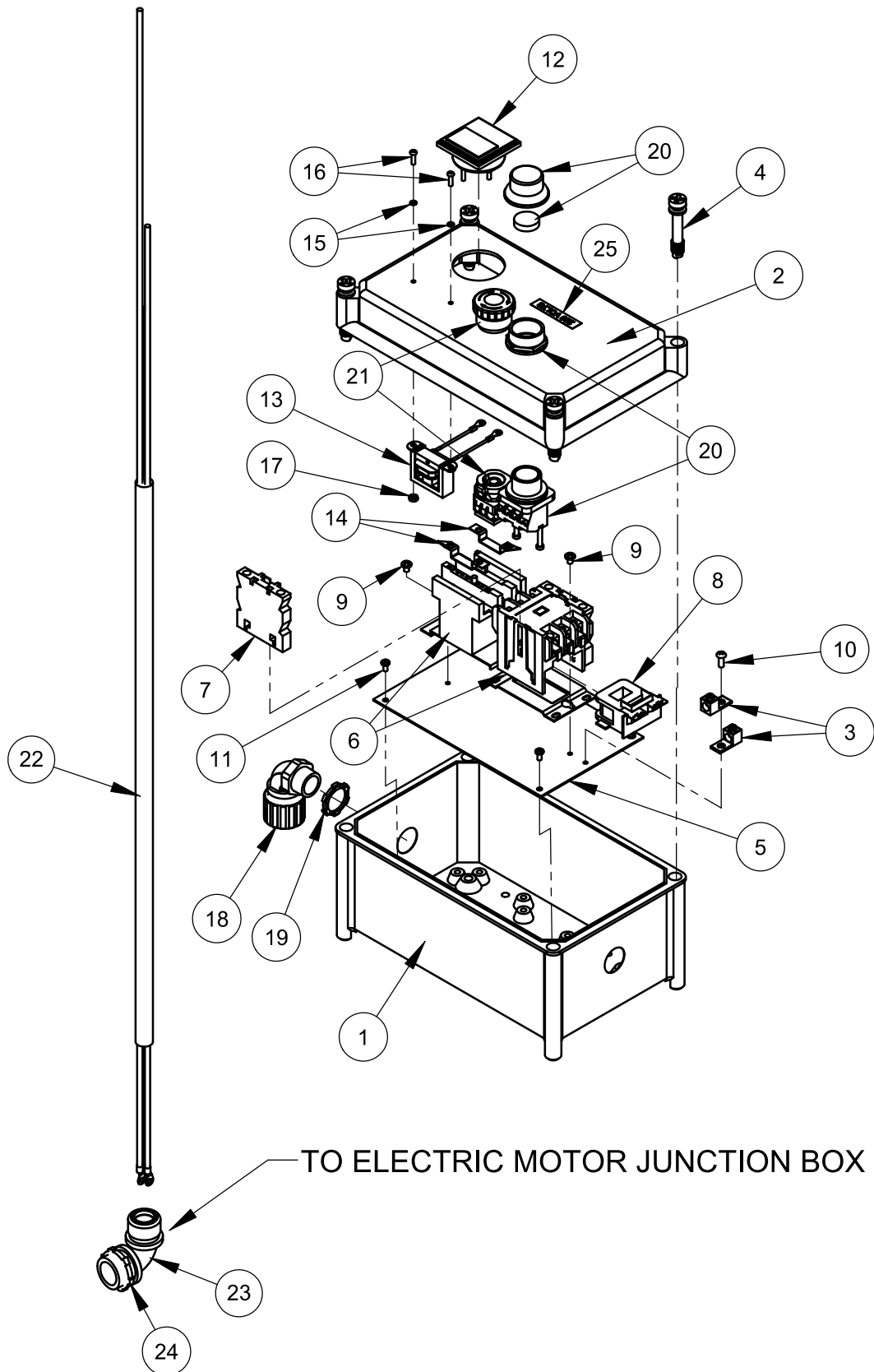

Starter Box Assembly, 7.5 HP, 1-Phase, 230V #6048355

ITEM	PART NO.	QTY.	DESCRIPTION
1	6040300D	1	Starter Box Base
2	6010844	1	Electric Box Cover, 3 Hole
3	2800315	2	Grounding Lug
4	2701414	4	Fastener, Electrical Box Top
5	6040301C	1	Starter Box, Back Panel
6	2800332	1	Starter, 190-240 Volt
7	2800335	2	Auxiliary Contact
8	2701327	1	Coil, 190-240 Volt
9	2900707	2	Machine Screw, Pan Hd., #10-32 x 1/4"
10	2900708	1	Machine Screw, Rd. Hd., #10-32 x 1/2"
11	2900676	4	Machine Screw, Pan Hd., M4 x 8mm
12	2800254	1	Amp Meter, 0-40 AC, 1 Phase
13	2800085	1	Transformer, 115V
14	2700625	2	Heater, # E-67
15	2900092	2	Lock Washer, #6 Split
16	2900090	2	Machine Screw, Rd. Hd., #6-32 x 1/2"
17	2900091	2	Hex Nut, #6-32
18	2802052	1	Connector, 3/4" Cord 90 Deg, Nylon
19	2801304	1	Lock Nut, 3/4"
20	6011305	1	Start Pushbutton Assembly
	2701391	1	Cap, Black Flush
	2701392	1	Contact Block (N.O.)
	2800222	1	Clear Protective Boot
	2701390	1	Pushbutton Operation Body
21	2801367	1	E-Stop Switch
22	6040307	1	Cable Assy., 10 Ga., 3 Wire x 54"
23	2800695	1	Cord Grip, 5/8-3/4", 90 Deg.
24	2800193	1	Lock Nut, 1"
25	1800810	1	Voltage Label, 230V

2800332
INCLUDES
2701327

Starter Box Assembly, 7.5HP, 1-Phase, 230V #6048355

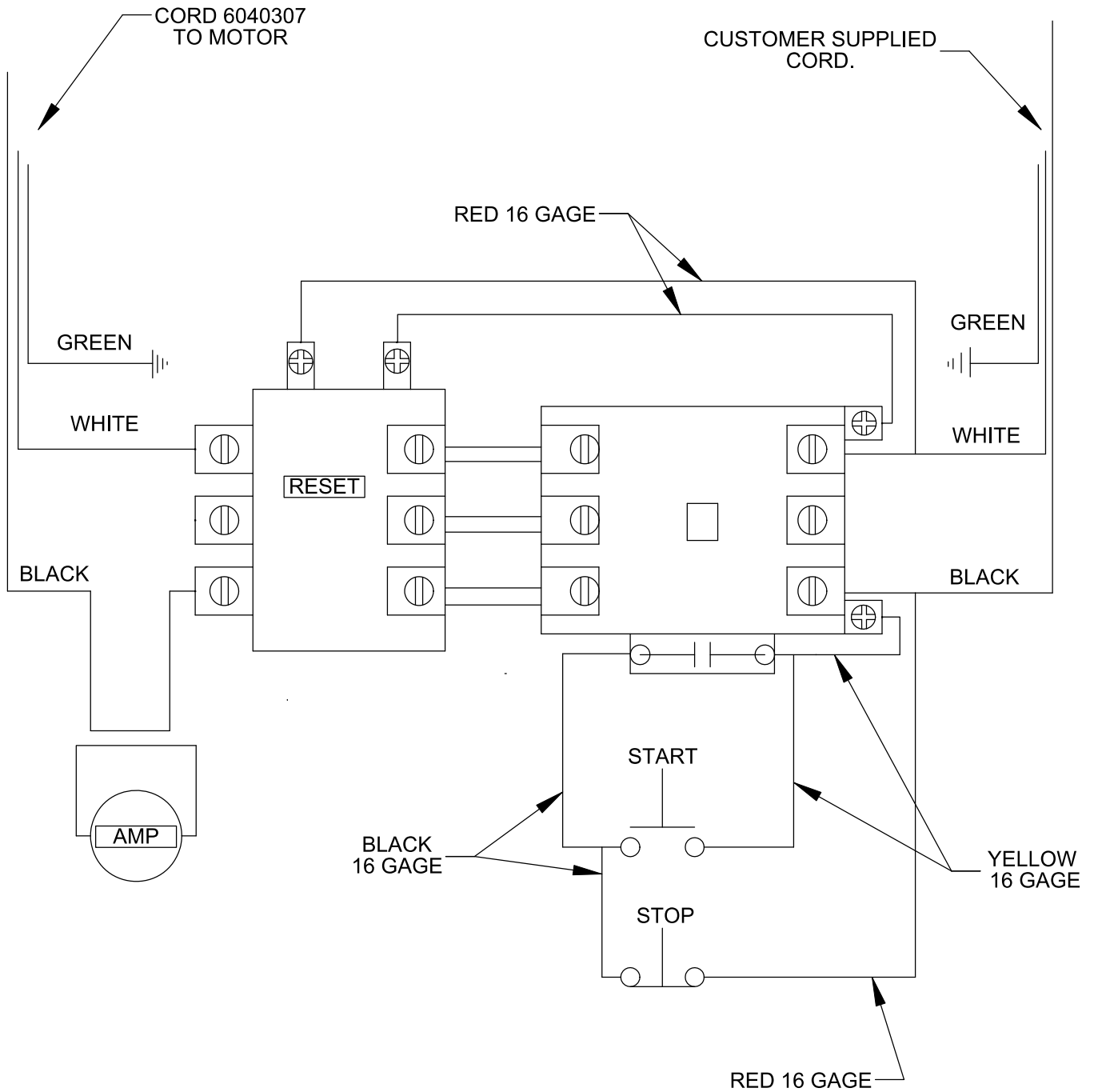

Intentionally Blank

6048972 CC1800 XL ELECTRIC MOTOR OPTION, 10HP, 230V, 3-PHASE

**DETAIL B
SCALE 1:2**

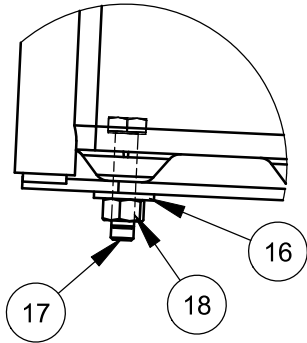

**DETAIL A
SCALE 1:2**

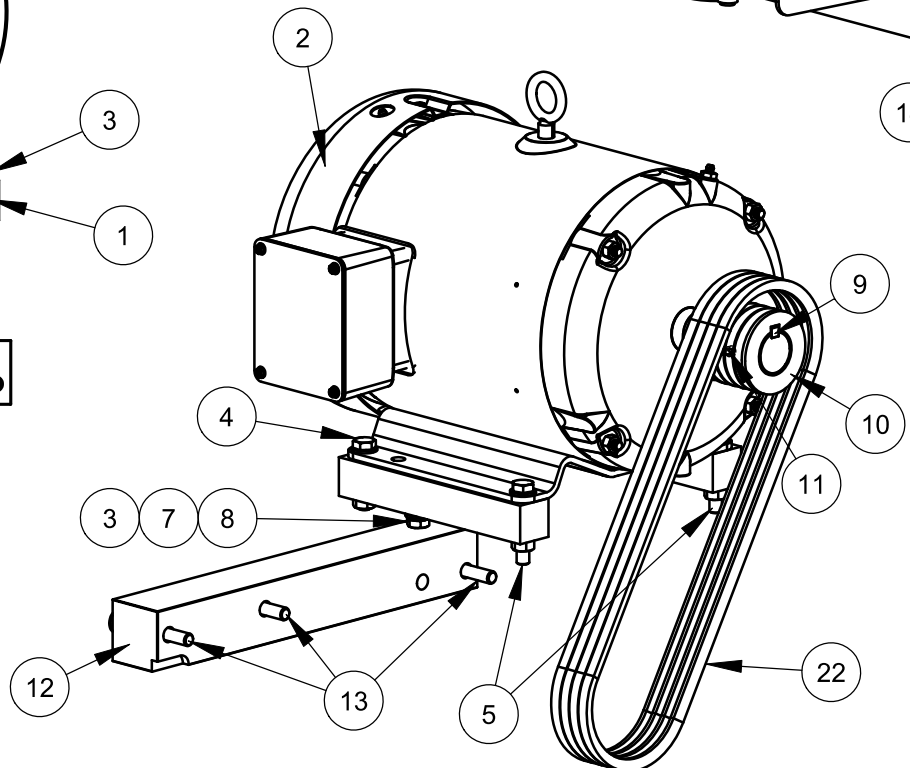
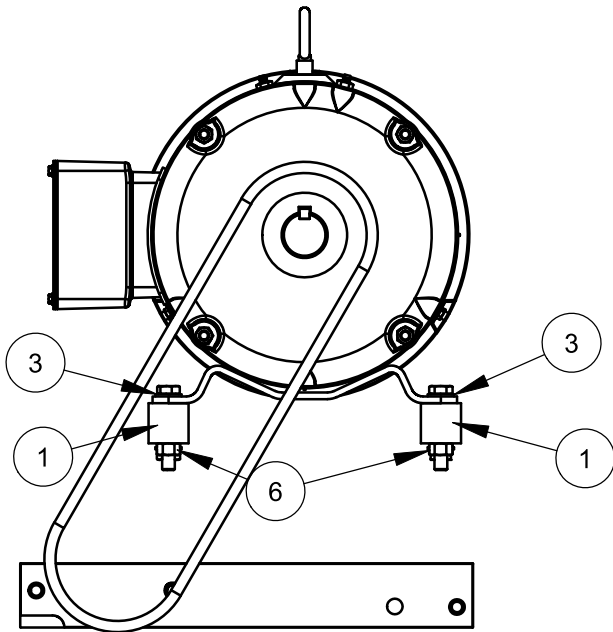
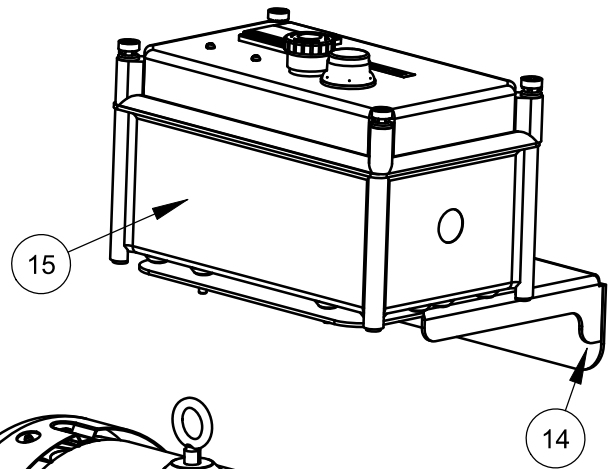
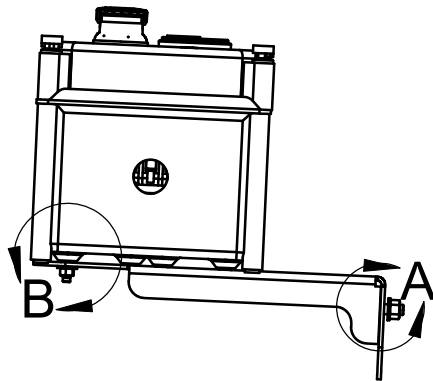
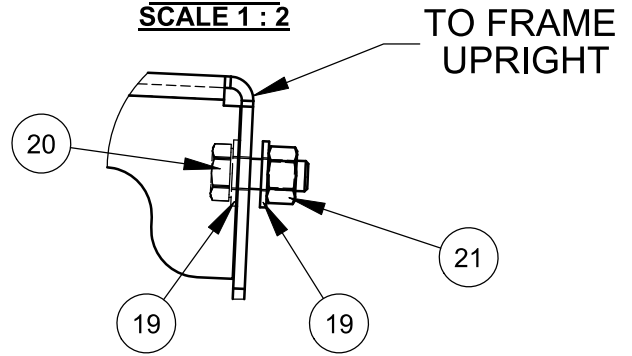

6048972 CC1800 XL ELECTRIC MOTOR OPTION, 10HP, 230V, 3-PHASE

ITEM NO.	PART NUMBER	QTY.	DESCRIPTION
1	6048100	2	Motor Spacer
2	2600187	1	Motor, 10hp 3 Phase Baldor
3	2900014	6	Flat Washer, 3/8" SAE
4	2900318	2	Cap Screw, Hex Hd., M10 x 50mm
5	2900338	2	Cap Screw, Hex Hd., M10 x 60mm
6	2900304	4	Lock Nut, M10 Nylon
7	2900321	2	Lock Washer, M10 Split
8	2900333	2	Cap Screw, Hex Hd., M10 x 25mm
9	6048046	1	Key, 5/16" Sq. x 1-1/2"
10	6048049	1	Sheave 2.65-3V-4 Groove/4L-1 Groove x 1-7/16"
11	2900036	1	Set Screw, Soc. Hd., 5/16-18 x 1/4"
12	6048319	1	Blade Guard Spacer
13	2900908	3	Cap Screw, Flat Hd. Soc., M10 x 80mm
14	6048326	1	Bracket, Electric Box
15	6048300	1	Starter Box Assembly, 10 HP -3PH, 230V
16	2900009	8	Flat Washer, 1/4" SAE
17	2900311	4	Cap Screw, Hex Hd., M6 x 25
18	2900302	4	Lock Nut, M6 Nylon
19	2900022	4	Flat Washer, 5/16" SAE
20	2900329	2	Capscrew, Hex Hd., M8 x 1.25 x 20mm
21	2900303	2	Lock Nut, M8 Nylon
22	2500037	4	V-Belt, 3VX375

Starter Box Assembly, 10 HP, 3-Phase, 230V #6048300

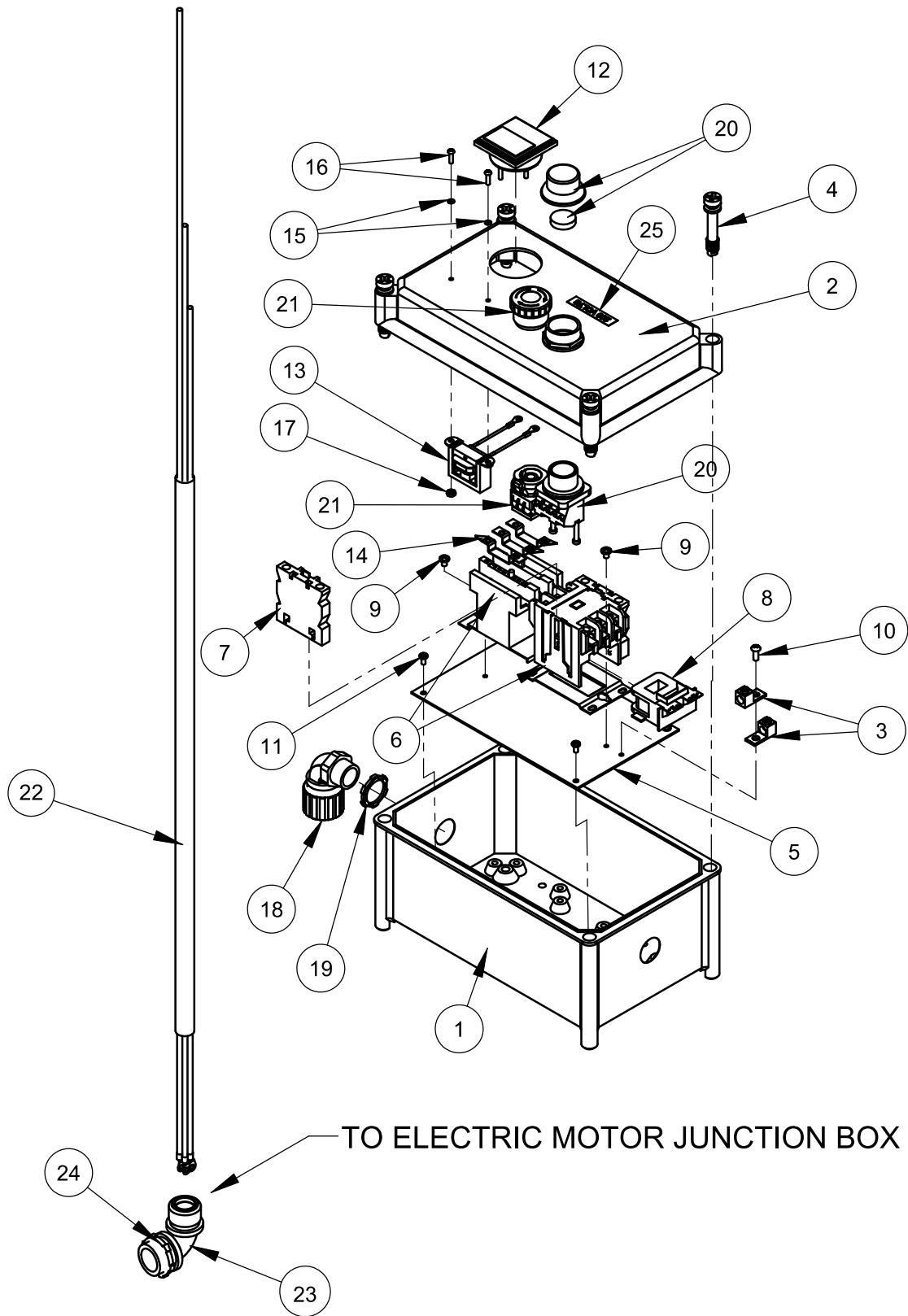

Starter Box Assembly, 10 HP, 3-Phase, 230V #6048300

ITEM NO.	PART NUMBER	QTY.	DESCRIPTION
1	6040300D	1	Starter Box Base
2	6010844	1	Electric Box Cover, 3 Hole
3	2800315	2	Grounding Lug
4	2701414	4	Fastener, Electrical Box Top
5	6040301C	1	Starter Box, Back Panel
6	2800332	1	Starter, 190-240 Volt
7	2800335	2	Auxiliary Contact
8	2701327	1	Coil, 190-240 Volt
9	2900707	2	Machine Screw, Pan Hd., #10-32 x 1/4"
10	2900708	1	Machine Screw, Rd. Hd., #10-32 x 1/2"
11	2900676	4	Machine Screw, Pan Hd., M4 x 8mm
12	2800253	1	Amp Meter, 0-40 AC
13	2800085	1	Transformer, 115V
14	2700625	3	Heater, # E-67
15	2900092	2	Lock Washer, #6 Split
16	2900090	2	Machine Screw, Rd. Hd., #6-32 x 1/2"
17	2900091	2	Hex Nut, #6-32
18	2802052	1	Connector, 3/4" Cord 90 Deg, Nylon
19	2801304	1	Lock Nut, 3/4"
20	6011305	1	Start Pushbutton Assembly
	2701391	1	Cap, Black Flush
	2701392	1	Contact Block (N.O.)
	2800222	1	Clear Protective Boot
	2701390A	1	Pushbutton Operation Body
21	2801367	1	E-Stop Switch
22	6040423	1	Cable Assy., 10 Ga., 4 Wire x 54"
23	2800695	1	Cord Grip, 5/8-3/4", 90 Deg.
24	2800193	1	Lock Nut, 1"
25	1800810	1	Voltage Label, 230V

2800332
INCLUDES
2701327

Starter Box Assembly, 10HP, 3-Phase, 230V 6048300

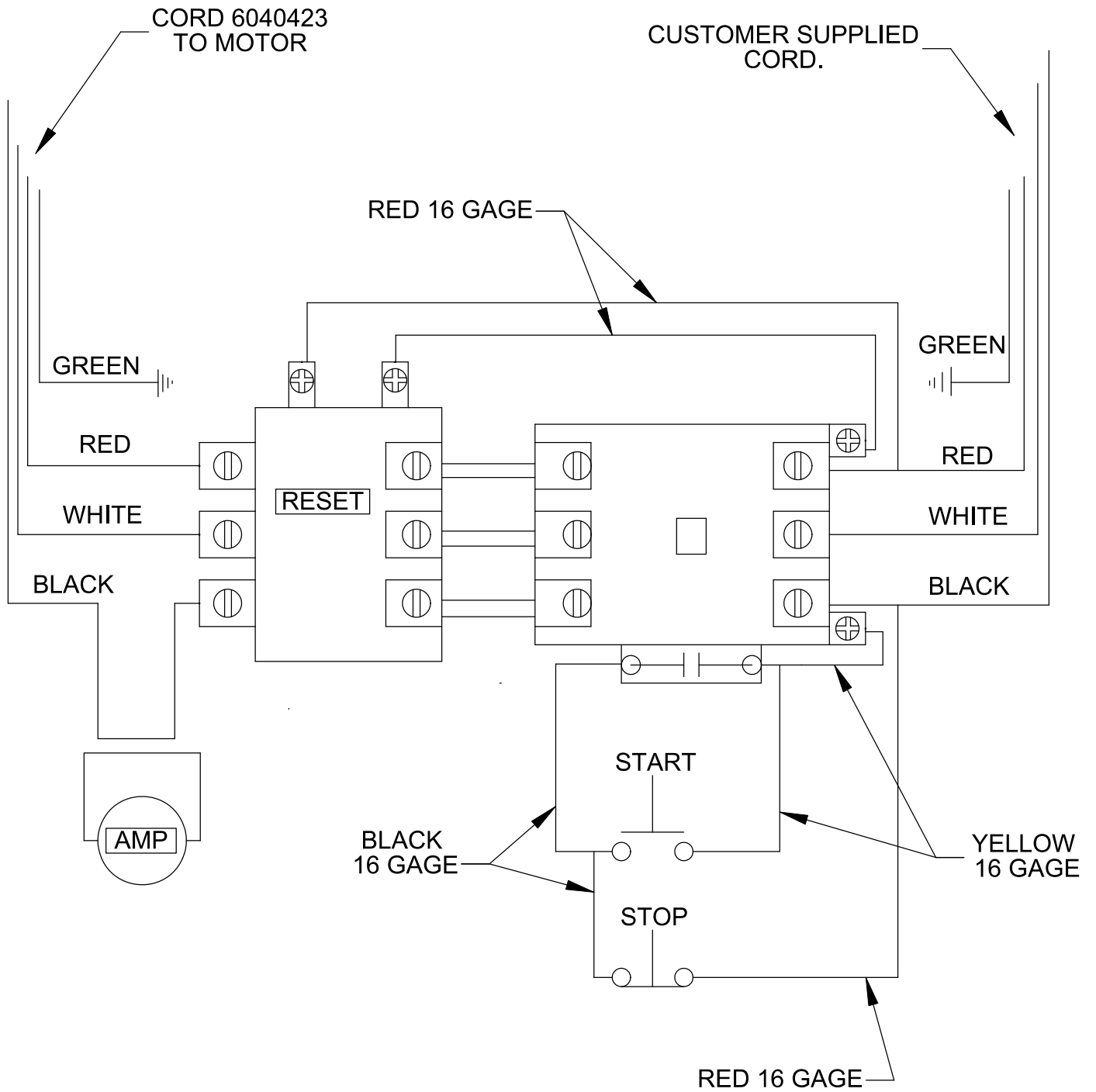

Intentionally Blank

6048973 CC1800 XL ELECTRIC MOTOR OPTION, 10HP, 460V, 3-PHASE

DETAIL B
SCALE 1 : 2

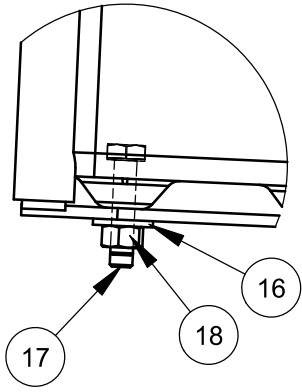

DETAIL A
SCALE 1 : 2

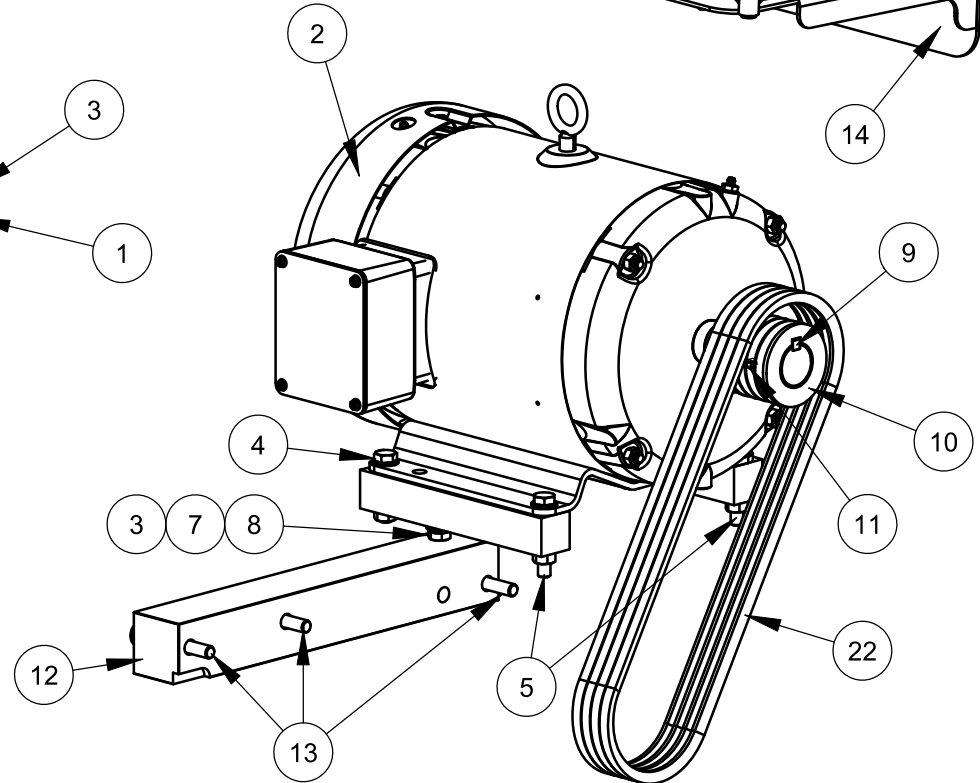
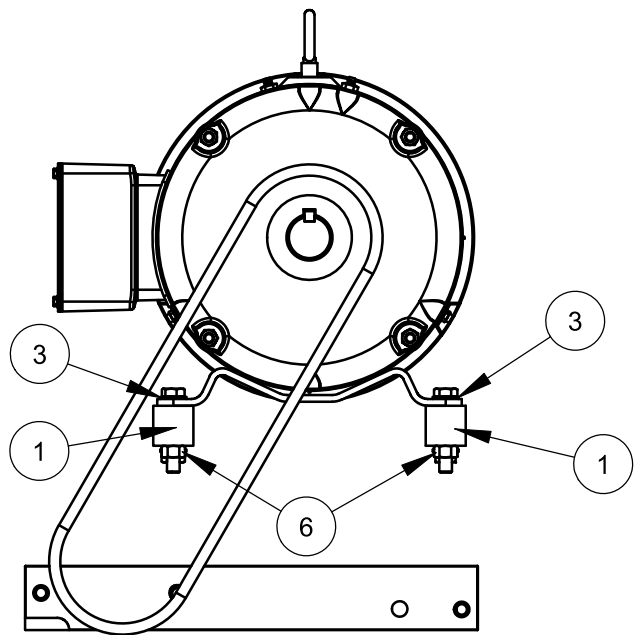
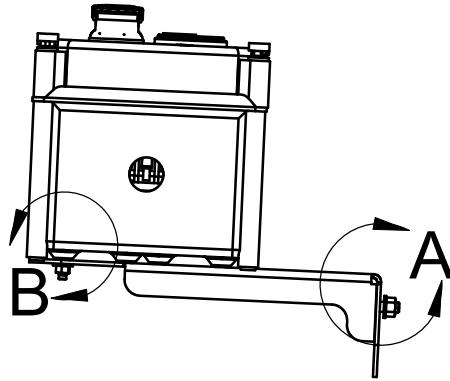
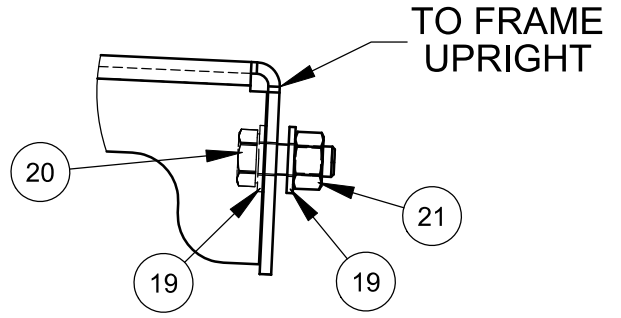

6048973 CC1800 XL ELECTRIC MOTOR OPTION, 10HP, 460V, 3-PHASE

ITEM NO.	PART NUMBER	QTY.	DESCRIPTION
1	6048100	2	Motor Spacer
2	2600187	1	Motor, 10hp 3 Phase Baldor
3	2900014	6	Flat Washer, 3/8" SAE
4	2900318	2	Cap Screw, Hex Hd., M10 x 50mm
5	2900338	2	Cap Screw, Hex Hd., M10 x 60mm
6	2900304	4	Lock Nut, M10 Nylon
7	2900321	2	Lock Washer, M10 Split
8	2900333	2	Cap Screw, Hex Hd., M10 x 25mm
9	6048046	1	Key, 5/16" Sq. x 1-1/2"
10	6048049	1	Sheave 2.65-3V-4 Groove/4L-1 Groove x 1-7/16"
11	2900036	1	Set Screw, Soc. Hd., 5/16-18 x 1/4"
12	6048319	1	Blade Guard Spacer
13	2900908	3	Cap Screw, Flat Hd. Soc., M10 x 80mm
14	6048326	1	Bracket, Electric Box
15	6048306	1	Starter Box Assembly, 10 HP -3PH, 460V
16	2900009	8	Flat Washer, 1/4" SAE
17	2900311	4	Cap Screw, Hex Hd., M6 x 25
18	2900302	4	Lock Nut, M6 Nylon
19	2900022	4	Flat Washer, 5/16" SAE
20	2900329	2	Capscrew, Hex Hd., M8 x 1.25 x 20mm
21	2900303	2	Lock Nut, M8 Nylon
22	2500037	4	V-Belt, 3VX375

Starter Box Assembly, 10 HP, 3-Phase, 460V #6048306

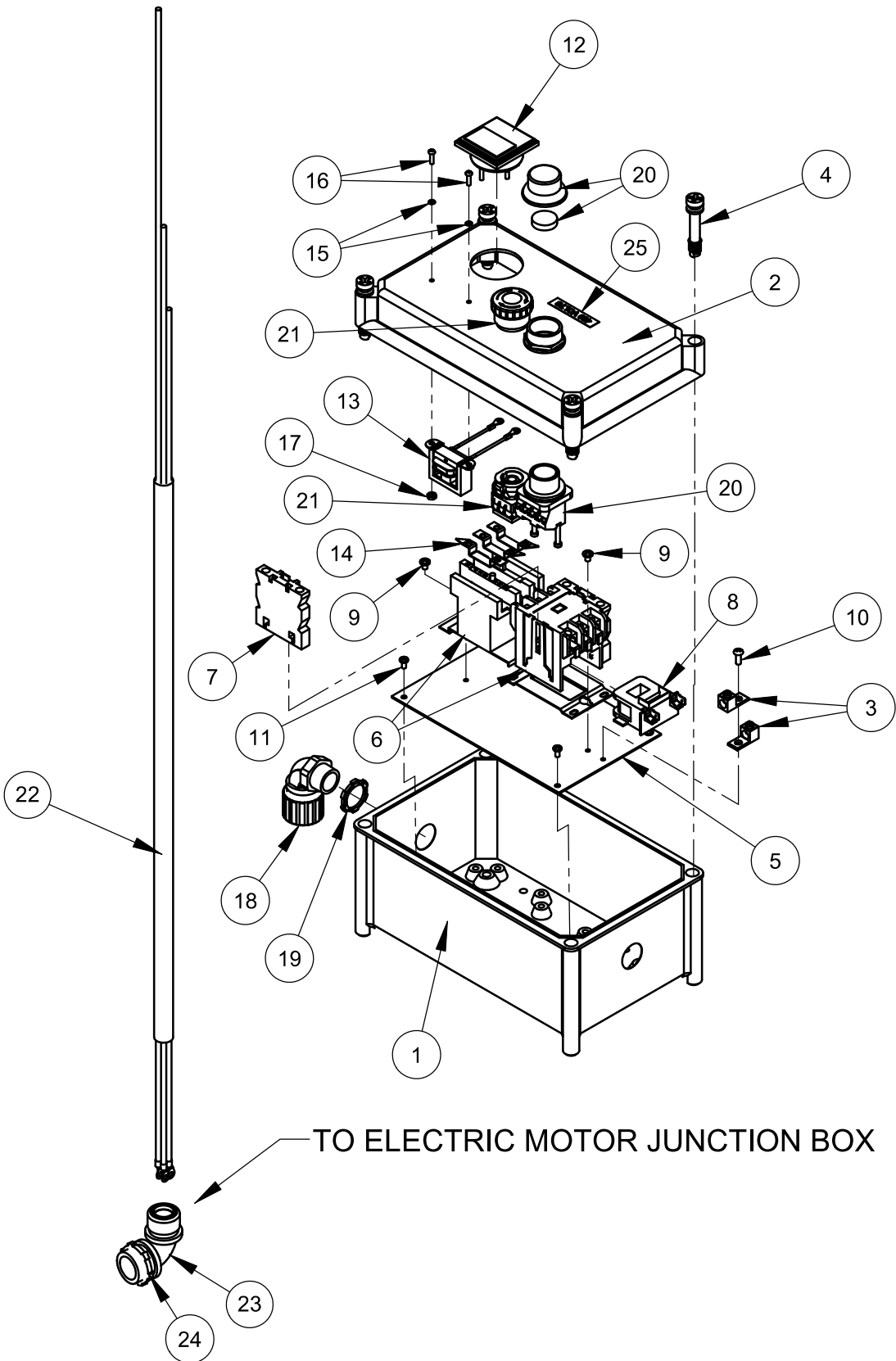

Starter Box Assembly, 10 HP, 3-Phase, 460V #6048306

ITEM	PART NO.	QTY.	DESCRIPTION
1	6040300D	1	Starter Box Base
2	6010844	1	Electric Box Cover, 3 Hole
3	2800315	2	Grounding Lug
4	2701414	4	Fastener, Electrical Box Top
5	6040301C	1	Starter Box, Back Panel
6	2800881	1	Starter, 380-480 Volt
7	2800335	2	Auxiliary Contact
8	2700889	1	Coil, 380-480V
9	2900707	2	Machine Screw, Pan Hd., #10-32 x 1/4"
10	2900708	1	Machine Screw, Rd. Hd., #10-32 x 1/2"
11	2900676	4	Machine Screw, Pan Hd., M4 x 8mm
12	2800252	1	Amp Meter, 0-20 AC
13	2800085	1	Transformer, 115V
14	2701457	3	Heater, # E57
15	2900092	2	Lock Washer, #6 Split
16	2900090	2	Machine Screw, Rd. Hd., #6-32 x 1/2"
17	2900091	2	Hex Nut, #6-32
18	2802052	1	Connector, 3/4" Cord 90 Deg, Nylon
19	2801304	1	Lock Nut, 3/4"
20	6011305	1	Start Pushbutton Assembly
	2701391	1	Cap, Black Flush
	2701392	1	Contact Block (N.O.)
	2800222	1	Clear Protective Boot
	2701390	1	Pushbutton Operation Body
21	2801367	1	E-Stop Switch
22	6040423	1	Cable Assy., 10 Ga., 4 Wire x 54"
23	2800695	1	Cord Grip, 5/8-3/4", 90 Deg.
24	2800193	1	Lock Nut, 1"
25	1800811	1	Voltage Label, 460V

2800881
INCLUDES
2700889

Intentionally Blank

CC1800 XL ELECTRIC MOTOR OPTION, 10HP, 575V, 3 PH. 6049029

**DETAIL B
SCALE 1 : 2**

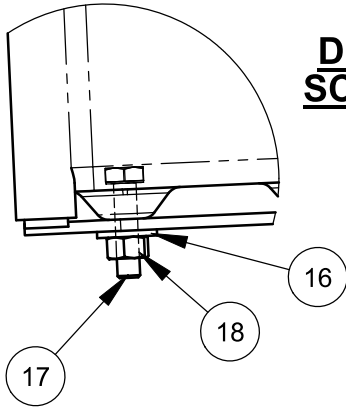

**DETAIL A
SCALE 1 : 2**

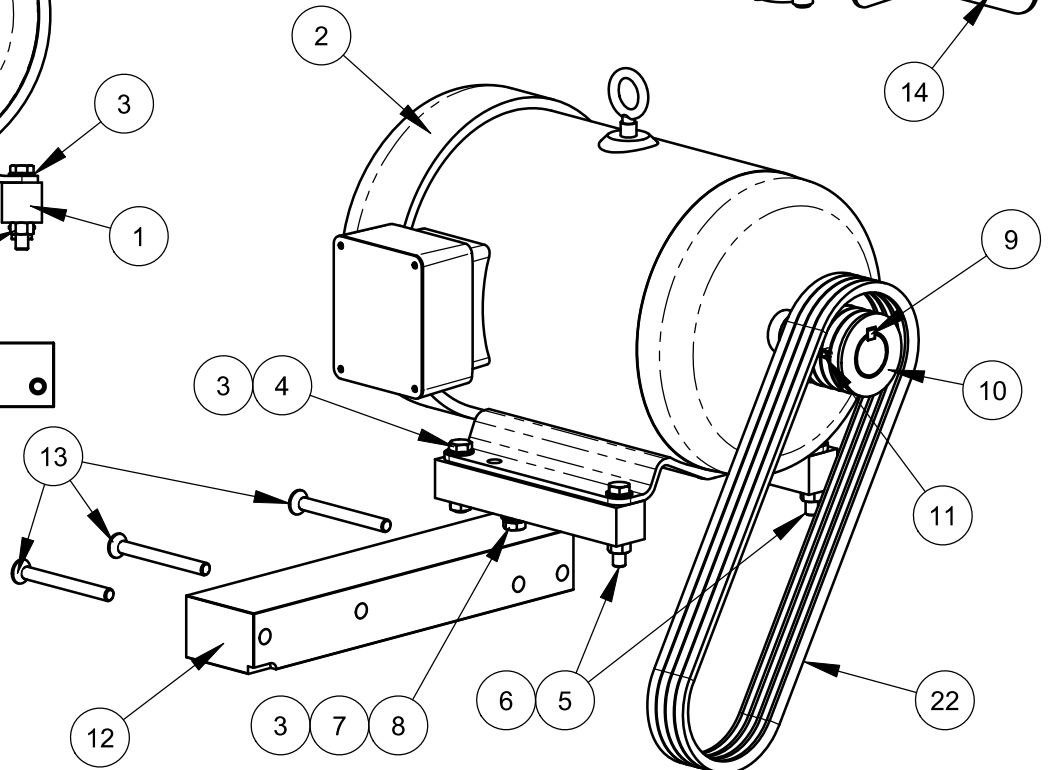
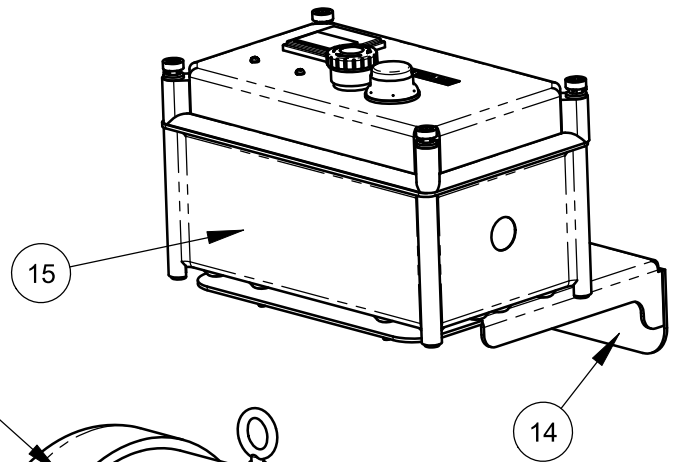
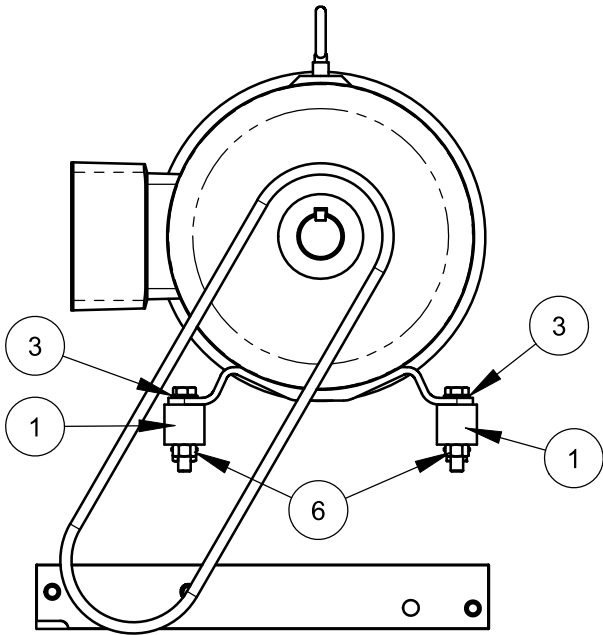
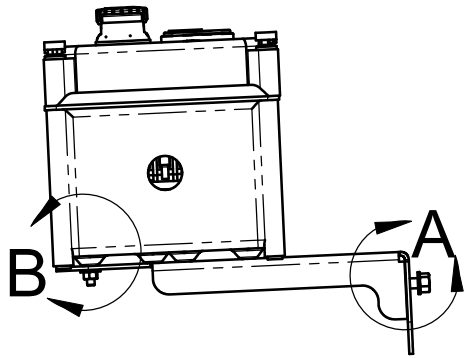
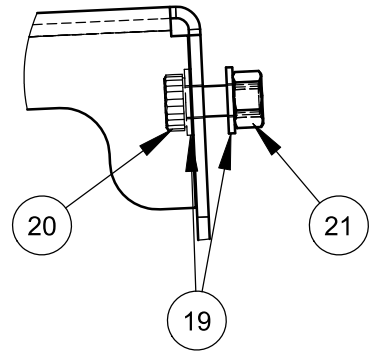

CC1800 XL ELECTRIC MOTOR OPTION, 10HP, 575V, 3-PH. 6049029

ITEM	PART NO.	QTY.	DESCRIPTION
1	6048100	2	Motor Spacer
2	2600703	1	Motor, 10 HP, 575V, 3 PH. Baldor
3	2900014	6	Flat Washer, 3/8" SAE
4	2900318	2	Cap Screw, Hex Hd., M10 x 50mm
5	2900338	2	Cap Screw, Hex Hd., M10 x 60mm
6	2900304	4	Lock Nut, M10 Nylon
7	2900321	2	Lock Washer, M10 Split
8	2900333	2	Cap Screw, Hex Hd., M10 x 25mm
9	6048046	1	Key, 5/16" Sq. x 1-1/2"
10	6048049	1	Sheave 2.65-3V-4 Groove/4L-1 Groove x 1-7/16"
11	2900036	1	Set Screw, Soc. Hd., 5/16-18 x 1/4"
12	6047308	1	Blade Guard Spacer, 3"
13	2901507	3	Cap Screw, Flat Hd., Soc., M10 x 100mm
14	6048326	1	Bracket, Electric Box
15	6048927	1	Starter Box Assembly, 10 HP -3PH, 575V
16	2900009	8	Flat Washer, 1/4" SAE
17	2900311	4	Cap Screw, Hex Hd., M6 x 25
18	2900302	4	Lock Nut, M6 Nylon
19	2900022	4	Flat Washer, 5/16" SAE
20	2900329	2	Capscrew, Hex Hd., M8 x 1.25 x 20mm
21	2900303	2	Lock Nut, M8 Nylon
22	2500037	4	V-Belt, 3VX375

Starter Box Assembly, 10 HP, 3-Phase, 575V #6048927

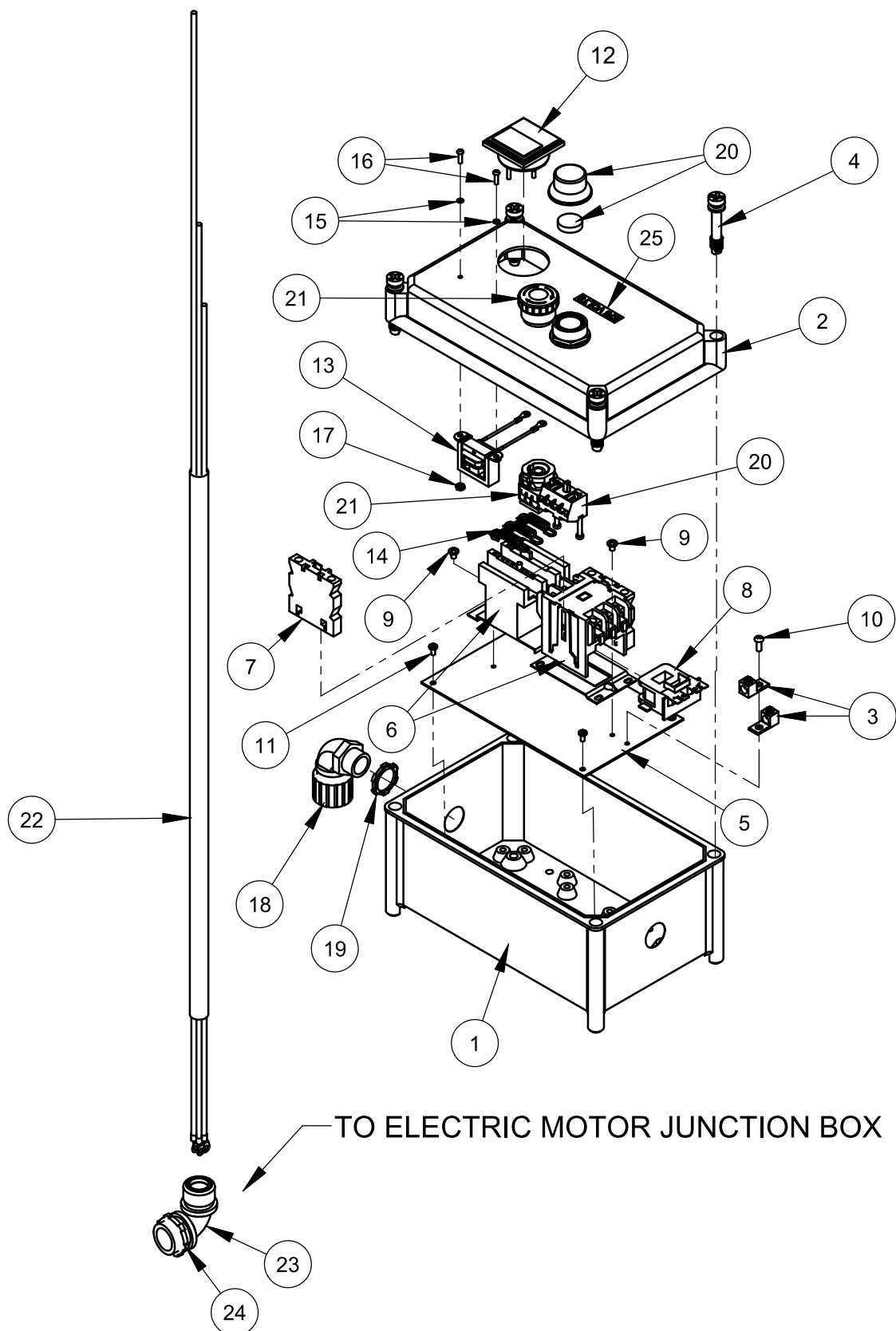

Starter Box Assembly, 10 HP, 3-Phase, 575V #6048927

ITEM NO.	PART NUMBER	QTY.	DESCRIPTION
1	6040300D	1	Starter Box Base
2	6010844	1	Electric Box Cover, 3 Hole
3	2800315	2	Grounding Lug
4	2701414	4	Fastener, Electrical Box Top
5	6040301C	1	Starter Box, Back Panel
6	2802051	1	Starter, 550-600 Volt
7	2800335	2	Auxiliary Contact
8	2800277	1	Coil, 550-600V
9	2900707	2	Machine Screw, Pan Hd., #10-32 x 1/4"
10	2900708	1	Machine Screw, Rd. Hd., #10-32 x 1/2"
11	2900676	4	Machine Screw, Pan Hd., M4 x 8mm
12	2800252	1	Amp Meter, 0-20 AC
13	2800085	1	Transformer, 115V
14	2800276	3	Heater, # E53
15	2900092	2	Lock Washer, #6 Split
16	2900090	2	Machine Screw, Rd. Hd., #6-32 x 1/2"
17	2900091	2	Hex Nut, #6-32
18	2802052	1	Connector, 3/4" Cord 90 Deg, Nylon
19	2801304	1	Lock Nut, 3/4"
20	6011305	1	Start Pushbutton Assembly
	2701391	1	Cap, Black Flush
	2701392	1	Contact Block (N.O.)
	2800222	1	Clear Protective Boot
	2701390	1	Push Button Body
21	2801367	1	E-Stop Switch
22	6040423	1	Cable Assy., 10 Ga., 4 Wire x 54"
23	2800695	1	Cord Grip, 5/8-3/4", 90 Deg.
24	2800193	1	Lock Nut, 1"
25	1800812	1	Voltage Label, 575V

2802051
INCLUDES
2800277

Starter Box Assembly, 10 HP, 3-Phase, 575V #6048927

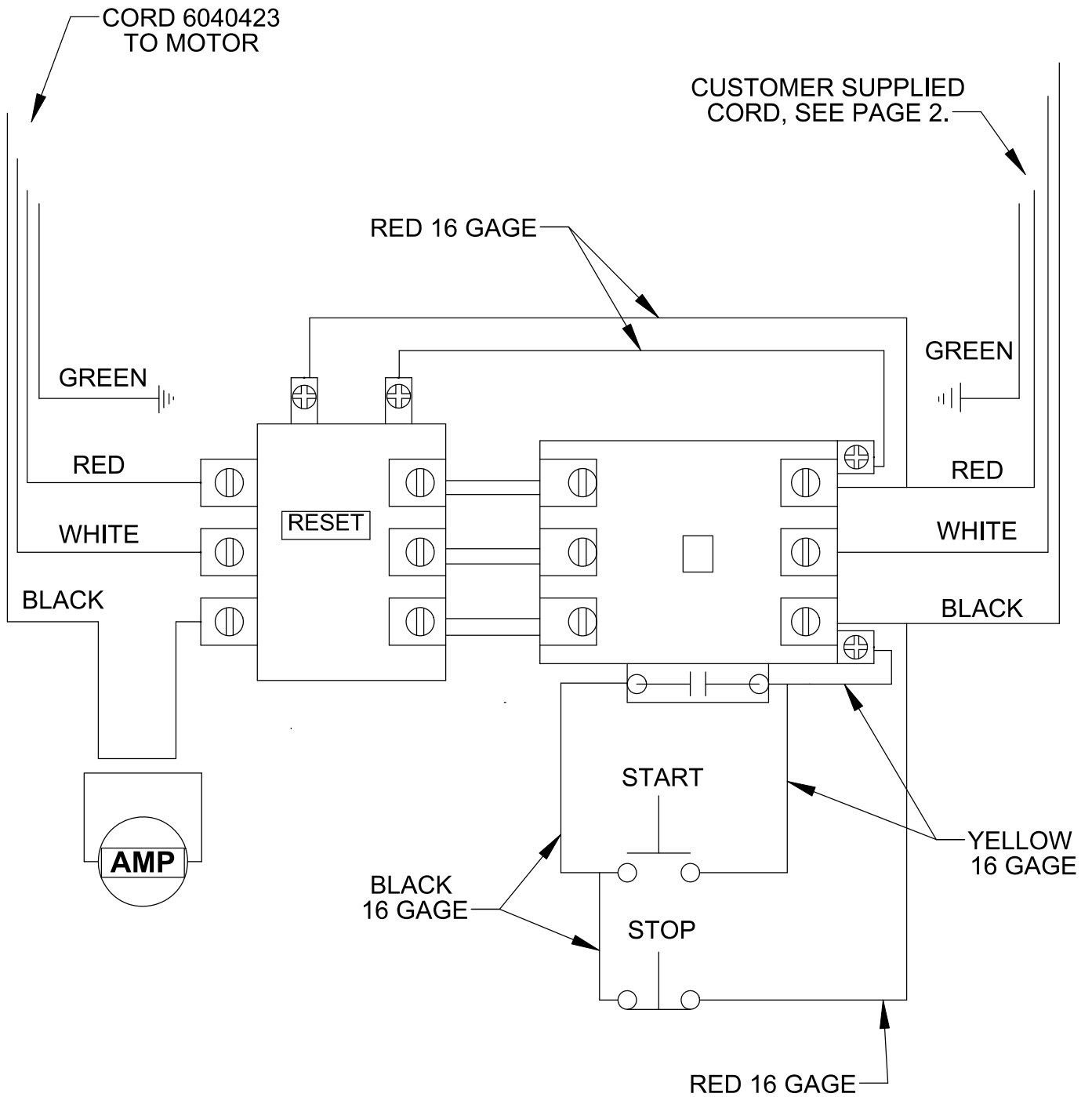

Weight Bar Assembly
#6048959

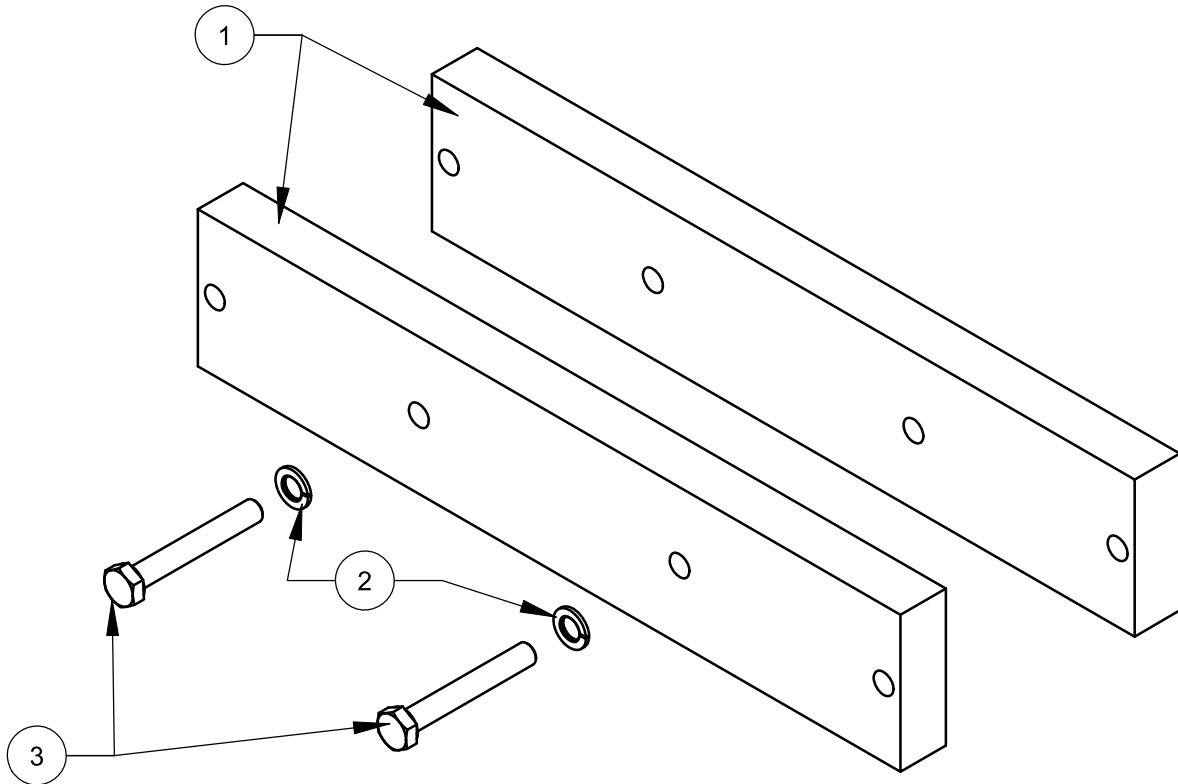

ITEM NO.	PART NUMBER	QTY.	DESCRIPTION
1	6048067	2	Saw Weight, 13 Pound
2	2900321	2	Lock Washer, M10 Split
3	2900334	2	Cap Screw, Hex Hd., M10 x 70mm

6054000: HYDRAULIC MOTOR OPTION, 1.16 CI / REV

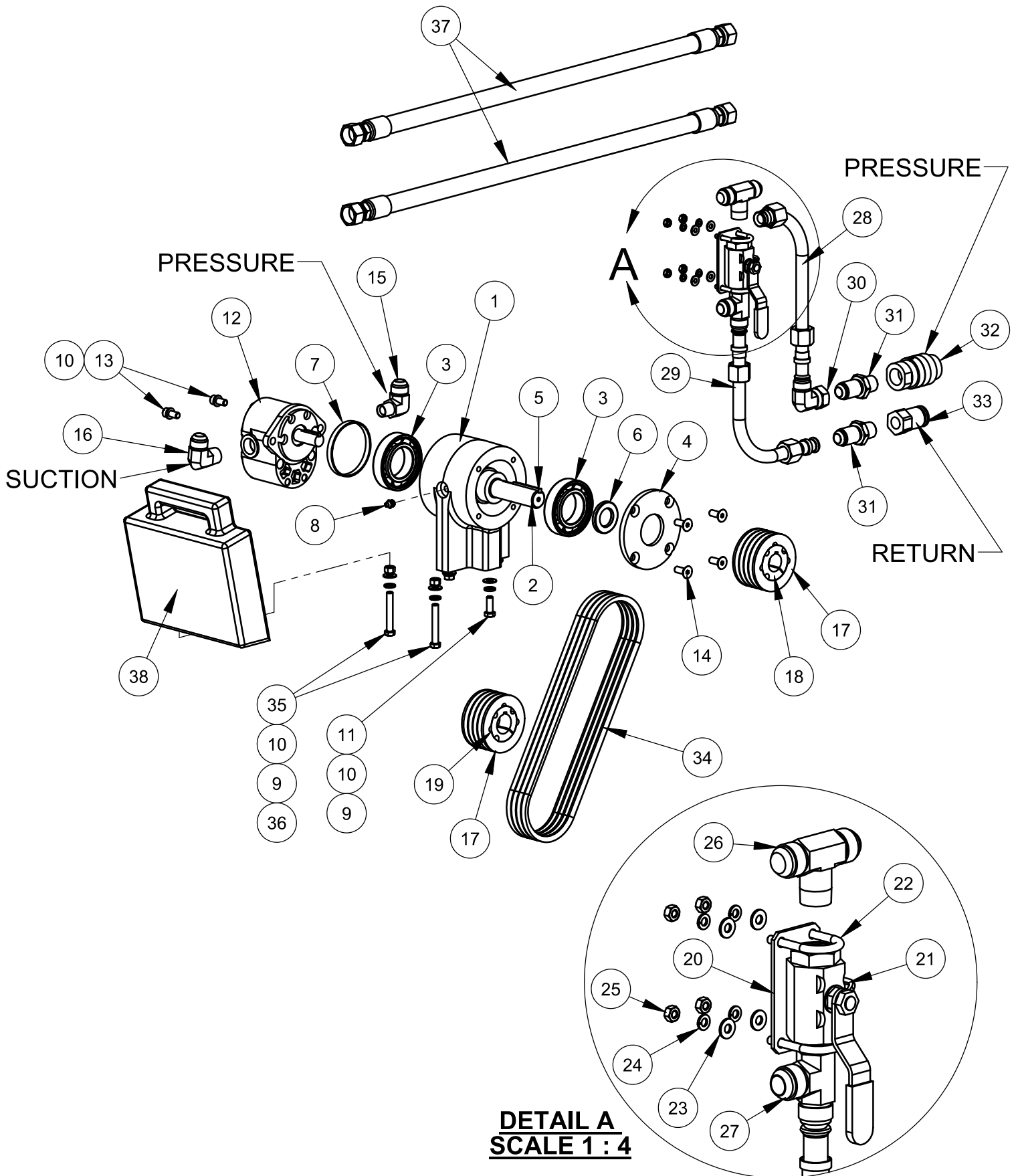

6054000: HYDRAULIC MOTOR OPTION, 1.16 CI / REV

ITEM NO.	PART NUMBER	QTY.	DESCRIPTION
1	6048115	1	Pillow Block
2	6048116	1	Hydraulic Spindle Shaft
3	2500686	2	Bearing, 50mm x 90mm x 20mm
4	6048117	1	Seal Plate
5	6048134	1	Key, 1/4" Sq. x 2-1/4"
6	3200004	1	Seal, 1-1/8" x 2" x 1/4"
7	4699901	1	Shim For Hydraulic Spindle Shaft
8	2900062	1	Grease Fitting, 1/8" NPT
9	2900014	6	Flat Washer, 3/8" SAE
10	2900006	8	Lock Washer, 3/8" Split
11	2900005	4	Cap Screw, Hex Hd., 3/8-16 x 1"
12	2600062	1	Hydraulic Motor, Danfoss 1.16 cu. in.
13	2900976	2	Cap Screw, Soc. Hd., 3/8-16 x 3/4"
14	2900235	4	Cap Screw, Flat Hd., 3/8-16 x 1"
15	3200110	1	Elbow, 1/2" M. Pipe to 3/4" M. JIC
16	3200086	1	Elbow, 3/4" M. Pipe to 3/4" M. JIC
17	2500621	2	Sheave, 3V-3.65-4 Groove (1610)
18	2500031	1	Taper Bushing, 1-1/8" w/Set Screws
19	2500337	1	Taper Bushing, 1-1/4"
20	2502192	1	Shim Plate
21	3200005	1	Ball Valve, 3/4" Pipe
22	2900369	2	U-Bolt, 3/4" Pipe
23	2900009	4	Flat Washer, 1/4" SAE
24	2900024	4	Lock Washer, 1/4" Split
25	2900125	4	Hex Nut, 1/4-20
26	3201738	1	3/4" MPT X 3/4" MJIC TEE
27	3200509	1	Run Tee, 3/4" M. Pipe x 3/4" M. JIC
28	6048633	1	Hydraulic Tube Assy., 3/4"
29	6048634	1	Hydraulic Tube Assy., 3/4"
30	3200417	1	Elbow, 3/4" F. JIC to 3/4" M. JIC
31	3200398	2	3/4" MPT x 3/4" MJIC Bulkhead Fitting
32	3200100	1	Coupler, 3/4" Quick Disconnect
33	3200101	1	Nipple, 3/4" Quick Disconnect
34	2500037	4	V-Belt, 3VX375
35	2900521	2	Tap Bolt, Hex Hd., 3/8-16 x 2-1/2"
36	2900033	2	Hex Nut, 3/8-16
37	6048845	2	Hose Assy, 3/4 x 33-1/2"
38	6048255	1	Saw Weight

6054001: HYDRAULIC MOTOR OPTION, 1.55 CI / REV

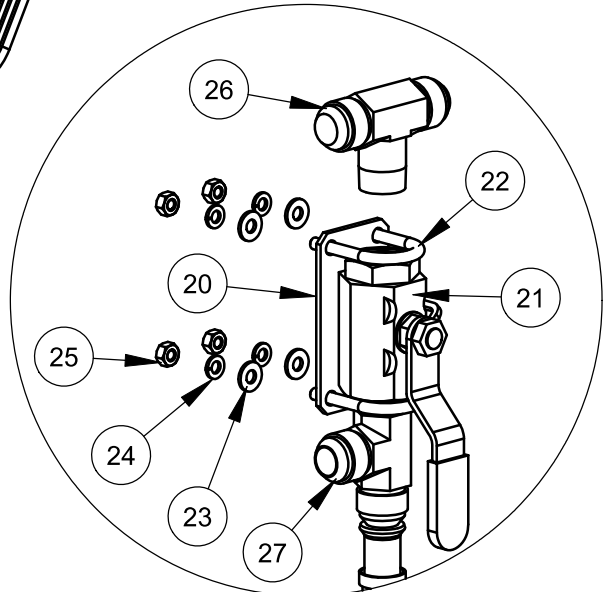
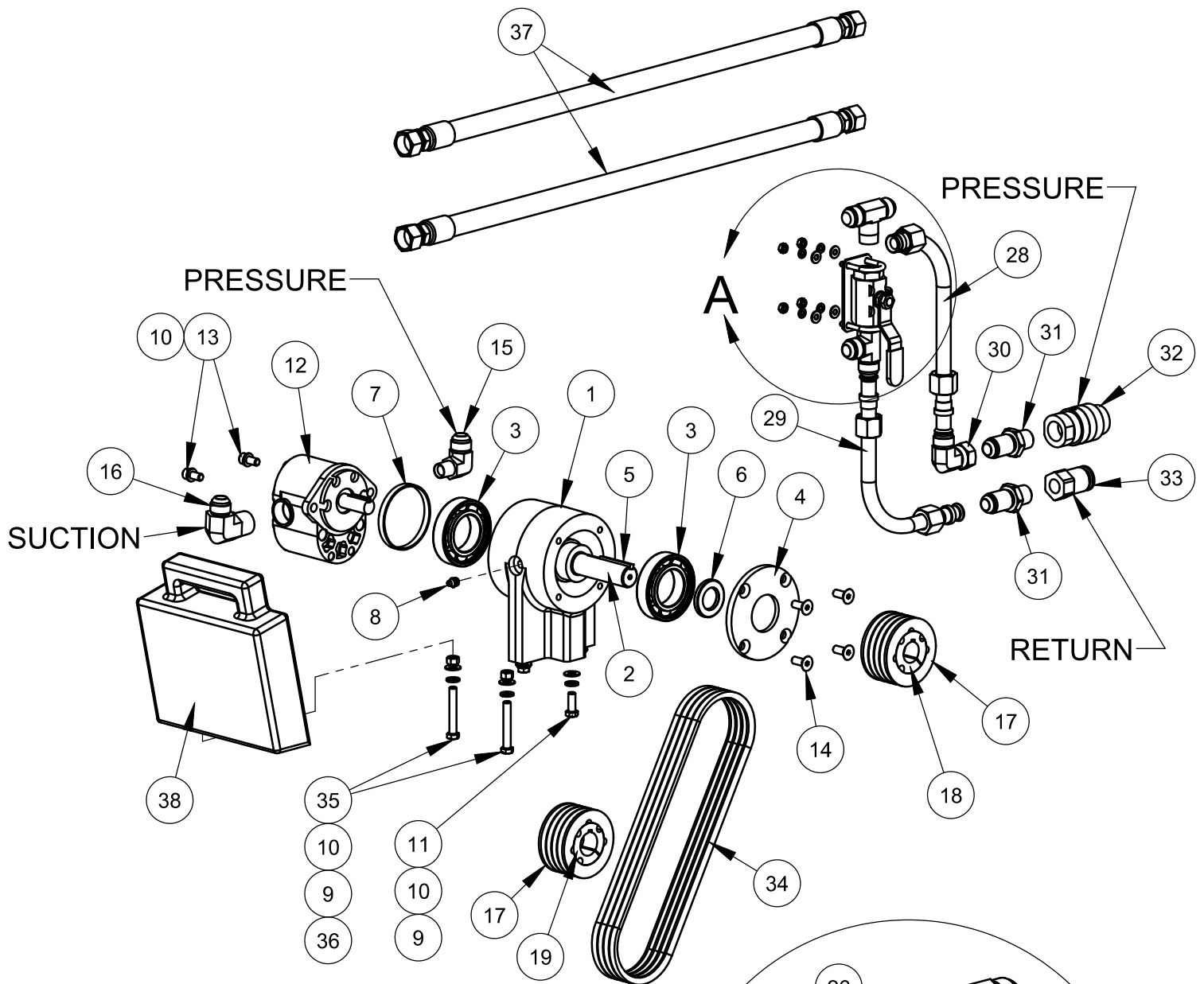

DETAIL A
SCALE 1 : 4

6054001: HYDRAULIC MOTOR OPTION, 1.55 CI / REV

ITEM NO.	PART NUMBER	QTY.	DESCRIPTION
1	6048115	1	Pillow Block
2	6048116	1	Hydraulic Spindle Shaft
3	2500686	2	Bearing, 50mm x 90mm x 20mm
4	6048117	1	Seal Plate
5	6048134	1	Key, 1/4" Sq. x 2-1/4"
6	3200004	1	Seal, 1-1/8" x 2" x 1/4"
7	4699901	1	Shim For Hydraulic Spindle Shaft
8	2900062	1	Grease Fitting, 1/8" NPT
9	2900014	6	Flat Washer, 3/8" SAE
10	2900006	8	Lock Washer, 3/8" Split
11	2900005	4	Cap Screw, Hex Hd., 3/8-16 x 1"
12	2600063	1	Hydraulic Motor, Danfoss 1.55 cu. in.
13	2900976	2	Cap Screw, Soc. Hd., 3/8-16 x 3/4"
14	2900235	4	Cap Screw, Flat Hd., 3/8-16 x 1"
15	3200110	1	Elbow, 1/2" M. Pipe to 3/4" M. JIC
16	3200111	1	Elbow, 1" M. Pipe to 3/4" M. JIC
17	2500621	2	Sheave, 3V-3.65-4 Groove (1610)
18	2500031	1	Taper Bushing, 1-1/8" w/Set Screws
19	2500337	1	Taper Bushing, 1-1/4"
20	2502192	1	Shim Plate
21	3200005	1	Ball Valve, 3/4" Pipe
22	2900369	2	U-Bolt, 3/4" Pipe
23	2900009	4	Flat Washer, 1/4" SAE
24	2900024	4	Lock Washer, 1/4" Split
25	2900125	4	Hex Nut, 1/4-20
26	3201738	1	3/4" MPT X 3/4" MJIC TEE
27	3200509	1	Run Tee, 3/4" M. Pipe x 3/4" M. JIC
28	6048633	1	Hydraulic Tube Assy., 3/4"
29	6048634	1	Hydraulic Tube Assy., 3/4"
30	3200417	1	Elbow, 3/4" F. JIC to 3/4" M. JIC
31	3200398	2	3/4" MPT x 3/4" MJIC Bulkhead Fitting
32	3200100	1	Coupler, 3/4" Quick Disconnect
33	3200101	1	Nipple, 3/4" Quick Disconnect
34	2500037	4	V-Belt, 3VX375
35	2900521	2	Tap Bolt, Hex Hd., 3/8-16 x 2-1/2"
36	2900033	2	Hex Nut, 3/8-16
37	6048845	2	Hose Assy, 3/4 x 33-1/2"
38	6048255	1	Saw Weight

6054002: HYDRAULIC MOTOR OPTION, 1.94 CI / REV

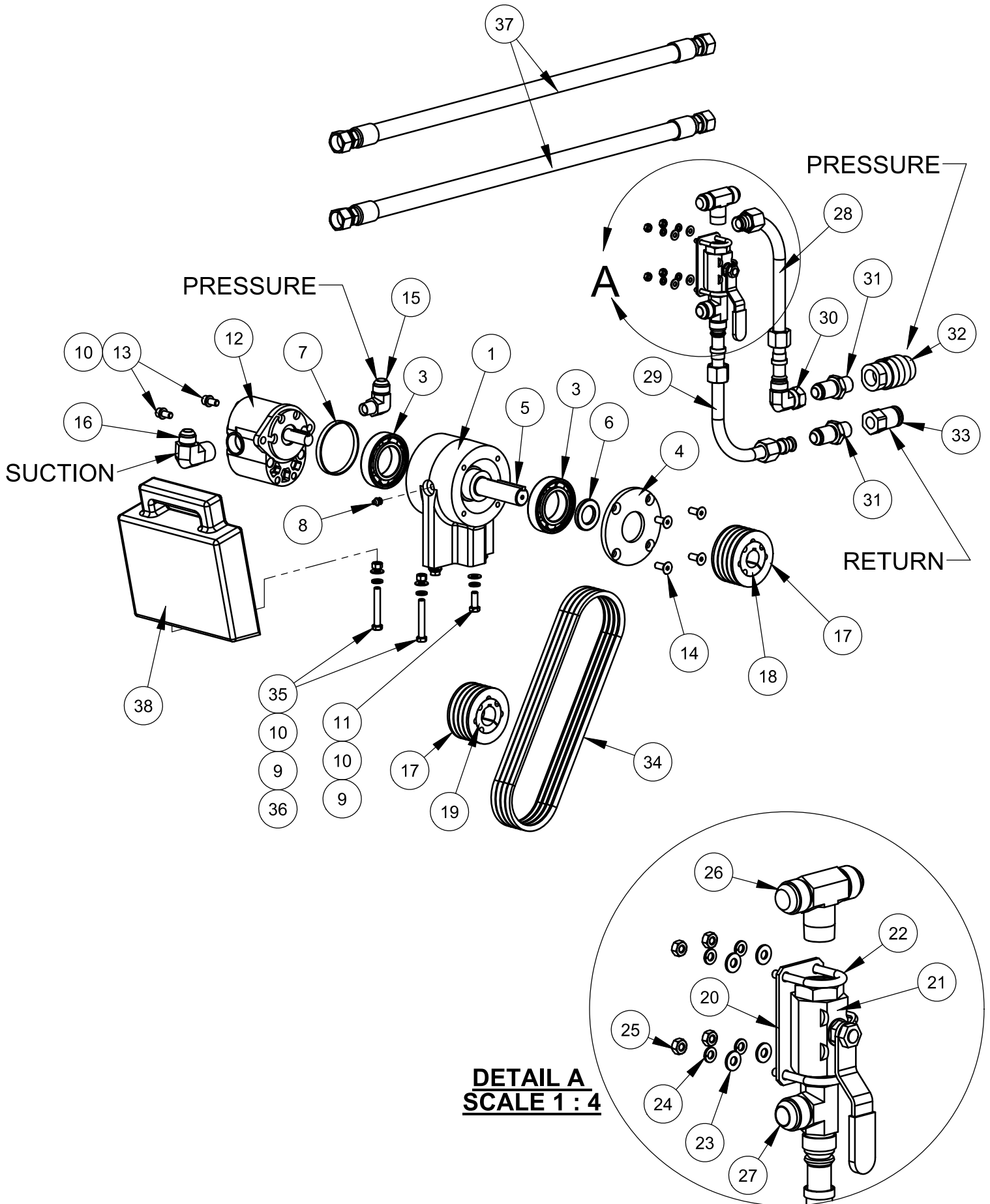

6054002: HYDRAULIC MOTOR OPTION, 1.94 CI / REV

ITEM NO.	PART NUMBER	QTY.	DESCRIPTION
1	6048115	1	Pillow Block
2	6048116	1	Hydraulic Spindle Shaft
3	2500686	2	Bearing, 50mm x 90mm x 20mm
4	6048117	1	Seal Plate
5	6048134	1	Key, 1/4" Sq. x 2-1/4"
6	3200004	1	Seal, 1-1/8" x 2" x 1/4"
7	4699901	1	Shim For Hydraulic Spindle Shaft
8	2900062	1	Grease Fitting, 1/8" NPT
9	2900014	6	Flat Washer, 3/8" SAE
10	2900006	8	Lock Washer, 3/8" Split
11	2900005	4	Cap Screw, Hex Hd., 3/8-16 x 1"
12	2600064	1	Hydraulic Motor, Danfoss 1.94 cu. in.
13	2900976	2	Cap Screw, Soc. Hd., 3/8-16 x 3/4"
14	2900235	4	Cap Screw, Flat Hd., 3/8-16 x 1"
15	3200110	1	Elbow, 1/2" M. Pipe to 3/4" M. JIC
16	3200111	1	Elbow, 1" M. Pipe to 3/4" M. JIC
17	2500621	2	Sheave, 3V-3.65-4 Groove (1610)
18	2500031	1	Taper Bushing, 1-1/8" w/Set Screws
19	2500337	1	Taper Bushing, 1-1/4"
20	2502192	1	Shim Plate
21	3200005	1	Ball Valve, 3/4" Pipe
22	2900369	2	U-Bolt, 3/4" Pipe
23	2900009	4	Flat Washer, 1/4" SAE
24	2900024	4	Lock Washer, 1/4" Split
25	2900125	4	Hex Nut, 1/4-20
26	3201738	1	3/4" MPT X 3/4" MJIC TEE
27	3200509	1	Run Tee, 3/4" M. Pipe x 3/4" M. JIC
28	6048633	1	Hydraulic Tube Assy., 3/4"
29	6048634	1	Hydraulic Tube Assy., 3/4"
30	3200417	1	Elbow, 3/4" F. JIC to 3/4" M. JIC
31	3200398	2	3/4" MPT x 3/4" MJIC Bulkhead Fitting
32	3200100	1	Coupler, 3/4" Quick Disconnect
33	3200101	1	Nipple, 3/4" Quick Disconnect
34	2500037	4	V-Belt, 3VX375
35	2900521	2	Tap Bolt, Hex Hd., 3/8-16 x 2-1/2"
36	2900033	2	Hex Nut, 3/8-16
37	6048845	2	Hose Assy, 3/4 x 33-1/2"
38	6048255	1	Saw Weight

14" Blade Guard Assembly #6048912

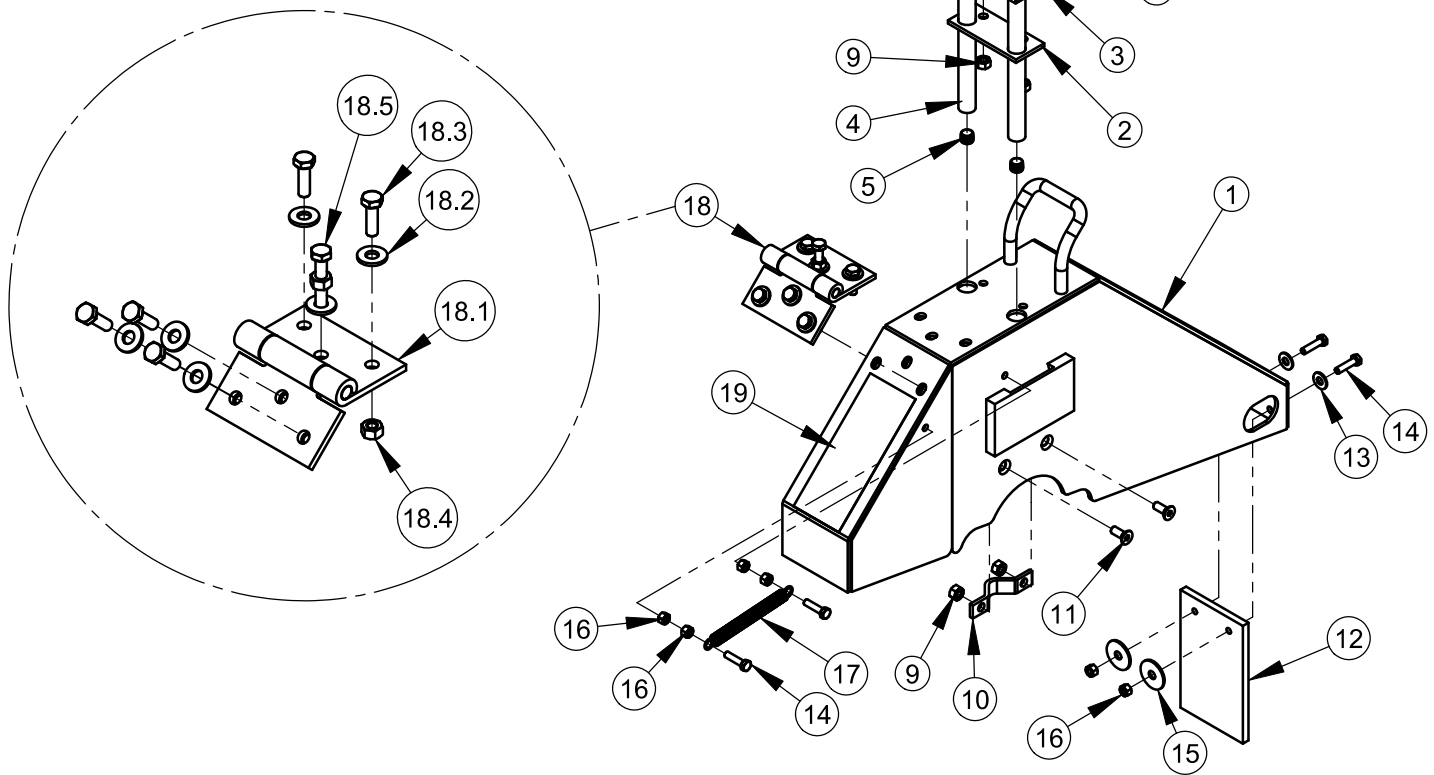

ITEM	PART NO.	QTY.	DESCRIPTION
1	6048911	1	14" Blade Guard
2	2500829	1	Water Manifold Gasket
3	6048123	1	Water Manifold
4	6048283	2	Water Tube for 14" Guard
5	3200001	3	Plug, 1/8" NPT
6	3200002	1	Fitting, 3/8" M. Pipe to 3/4" M. Garden
7	2900009	2	Flat Washer, 1/4" SAE
8	2900244	2	Cap Screw, Hex Hd., M6 x 45mm
9	2900302	6	Lock Nut, M6 Nylon
10	6048155	2	Water Tube Clamp
11	2900308	4	Cap Screw, Flat Hd. Soc., M6 x 16mm
12	6048039	1	Splash Flap
13	2900016	2	Flat Washer, #10 USS
14	2900309	4	Cap Screw, Hex Hd., M5 x 20mm
15	2900083	2	Fender Washer, 1/4" I.D. x 1-1/4" O.D.
16	2900301	6	Lock Nut, M5 Nylon
17	2500066	1	Spring, 3/8 X .055 X 3"
18	6048026	1	Hinge Assy., Metric Fasteners
18.1	2500270	1	Blade Guard Hinge
18.2	2900009	6	Flat Washer, 1/4" SAE
18.3	2900310	5	Cap Screw, Hex Hd., M6 x 20mm
18.4	2900302	7	Lock Nut, M6 Nylon
18.5	2900312	1	Cap Screw, Hex Hd., M6 x 35mm
19	1800001	1	Warning Label

20" Blade Guard Assembly
#6048904

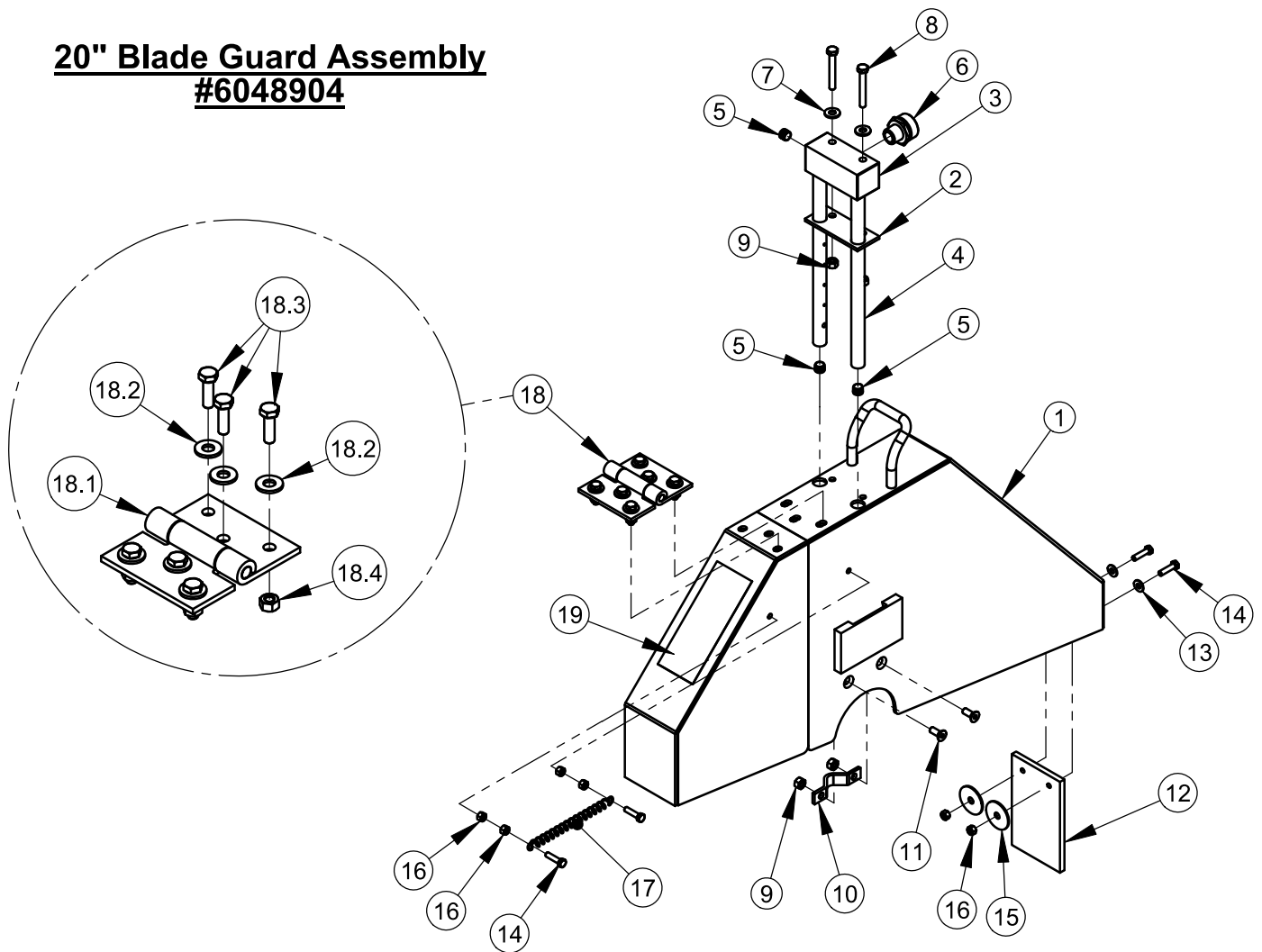

ITEM	PART NO.	QTY.	DESCRIPTION
1	6048905	1	20" Blade Guard
2	2500829	1	Water Manifold Gasket
3	6048123	1	Water Manifold
4	6010085	2	Water Tube for 20" Guard
5	3200001	3	Plug, 1/8" NPT
6	3200002	1	Fitting, 3/8" M. Pipe to 3/4" M. Garden
7	2900009	2	Flat Washer, 1/4" SAE
8	2900244	2	Cap Screw, Hex Hd., M6 x 45mm
9	2900302	6	Lock Nut, M6 Nylon
10	6048155	2	Water Tube Clamp
11	2900308	4	Cap Screw, Flat Hd. Soc., M6 x 16mm
12	6048039	1	Splash Flap
13	2900016	2	Flat Washer, #10 USS
14	2900309	4	Cap Screw, Hex Hd., M5 x 20mm
15	2900083	2	Fender Washer, 1/4" x 1-1/4"
16	2900301	6	Lock Nut, M5 Nylon
17	2500067	1	Spring, 3/8" x 4"
18	6048027	1	Hinge Assy., Metric Fasteners
18.1	2500270	1	Blade Guard Hinge
18.2	2900009	6	Flat Washer, 1/4" SAE
18.3	2900310	6	Cap Screw, Hex Hd., M6 x 20mm
18.4	2900302	6	Lock Nut, M6 Nylon
19	1800001	1	Warning Label

24" BLADE GUARD ASSEMBLY: 6048258

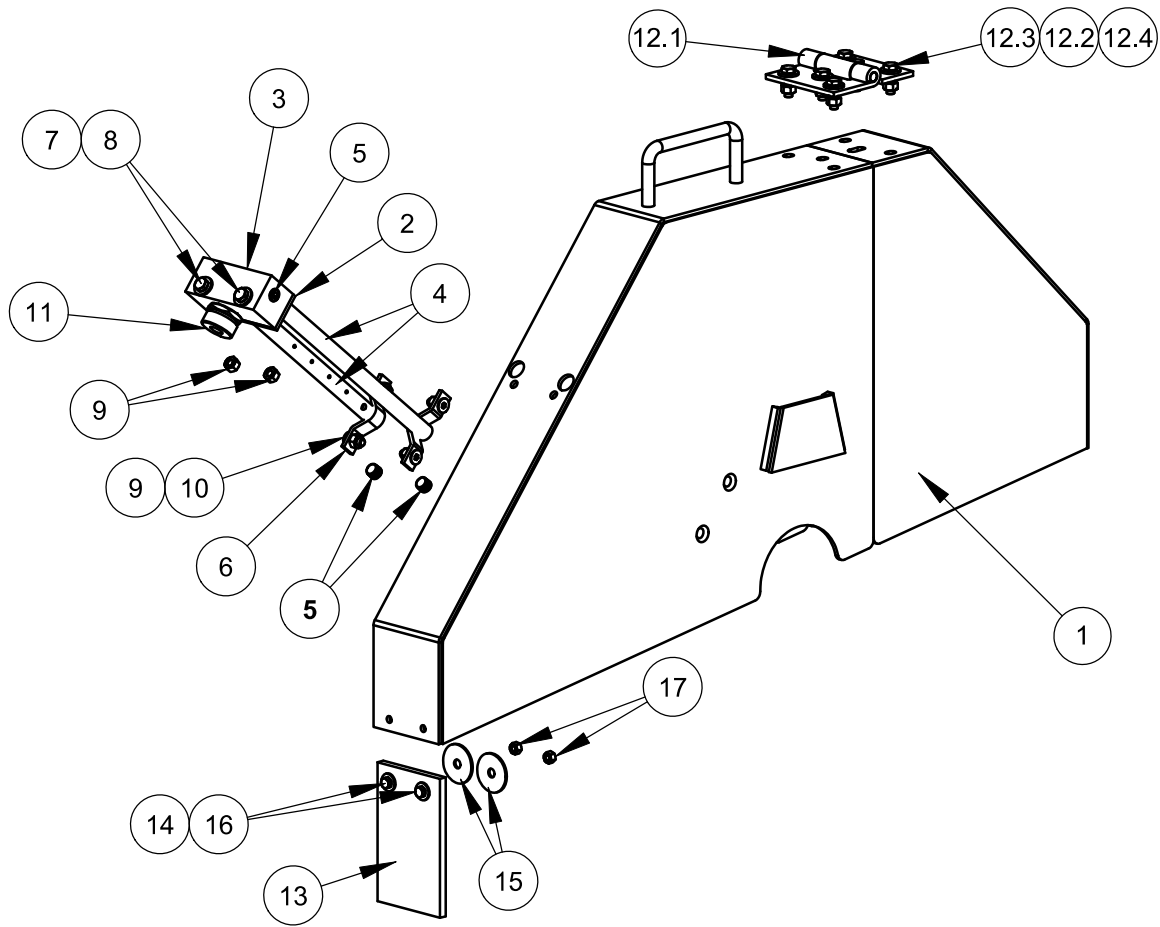

ITEM NO.	PART NUMBER	DESCRIPTION	QTY.
1	6048257	24" Blade Guard	1
2	2500829	Water Manifold Gasket	1
3	6048123	Water Manifold	1
4	6010085	Water Tube for 20" Guard	2
5	3200001	Plug, 1/8" NPT	3
6	6048155	Water Tube Clamp	2
7	2900009	Flat Washer, 1/4" SAE	2
8	2900244	Cap Screw, Hex Hd., M6 x 45mm	2
9	2900302	Lock Nut, M6 Nylon	6
10	2900308	Cap Screw, Flat Hd. Soc., M6 x 16mm	4
11	3200002	Fitting, 3/4" M. Pipe to 3/4" M. Garden	1
12	6048027	Hinge Assy., Metric Fasteners	1
12.1	2500270	Blade Guard Hinge	1
12.2	2900009	Flat Washer, 1/4" SAE	6
12.3	2900310	Cap Screw, Hex Hd., M6 x 20mm	6
12.4	2900302	Lock Nut, M6 Nylon	6
13	6048039	Splash Flap	1
14	2900016	Flat Washer, #10 USS	2
15	2900083	Fender Washer, 1/4" x 1-1/4"	2
16	2900309	Cap Screw, Hex Hd., M5 x 20mm	2
17	2900301	Lock Nut, M5 Nylon	2

6048873 BRAKE OPTION

**Attach Below Frame
Behind Right Rear Tire**

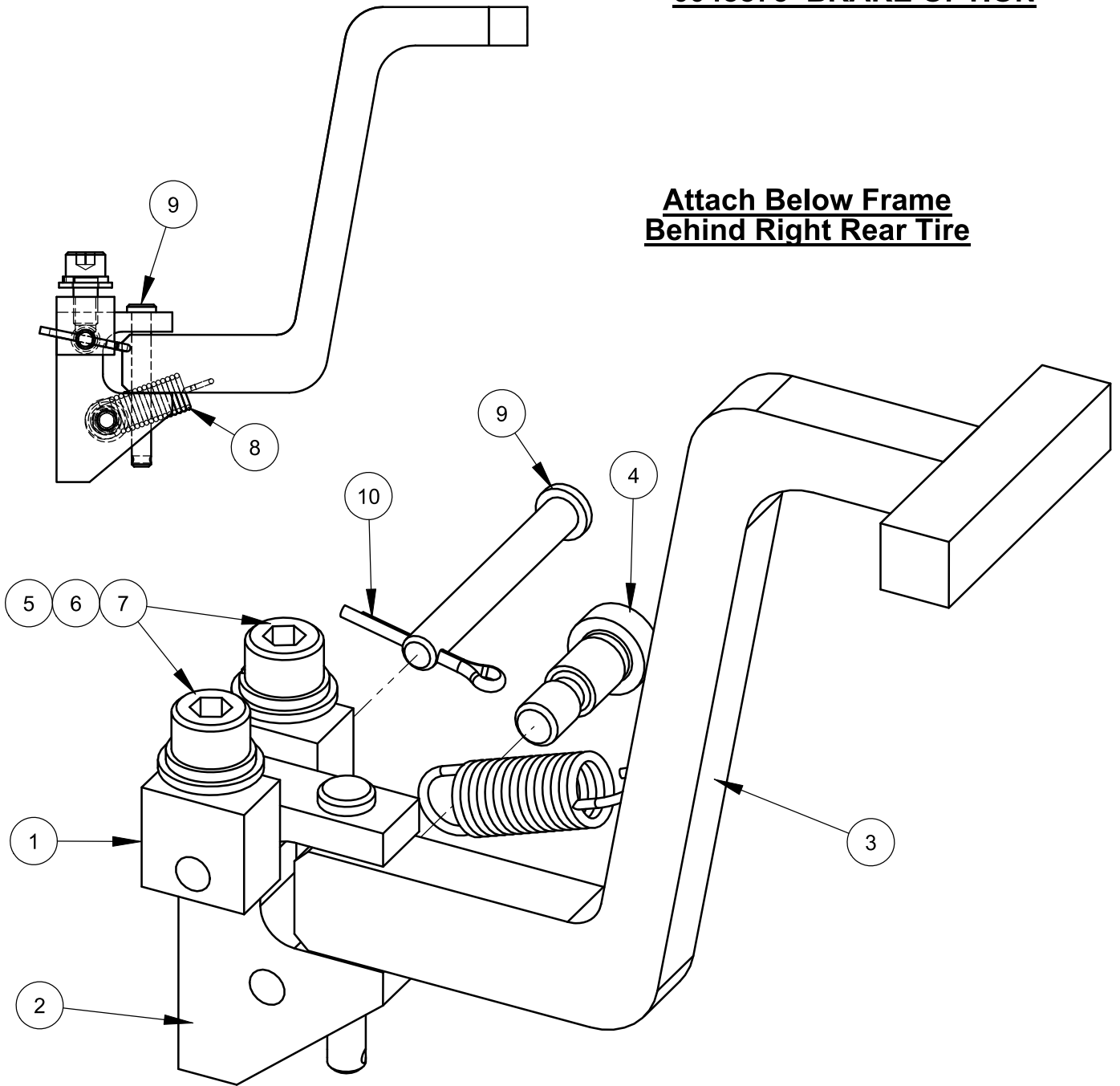

ITEM	PART NO.	QTY.	DESCRIPTION
1	6048868	2	Clevis Plate
2	6048867	1	Plate, Brake Pivot
3	6048869	1	Brake Pedal Weldment
4	2900672	1	Shoulder Screw, 3/8" x 1/2" (5/16-18)
5	2900022	2	Flat Washer, 5/16" SAE
6	2900031	2	Lock Washer, 5/16" Split
7	2900267	2	Cap Screw, Soc. Hd., M8-1.25 x 16mm
8	2500068	1	Spring, .063 x .50 x 1.75
9	2901404	2	1/4 x 2.0" Clevis Pin
10	2900034	1	Cotter Pin, 3/32" x 3/4"

EQUIPMENT AND PARTS WARRANTY

Diamond Products warrants all equipment manufactured by it against defects in workmanship or materials for a period of one (1) year from the date of shipment to Customer.

The responsibility of Diamond Products under this Warranty is limited to replacement or repair of defective parts at Diamond Products' Elyria, Ohio factory, or at a point designated by it, of such parts as shall appear to us upon inspection at such parts, to have been defective in material or workmanship, with expense for transportation and labor borne by Customer.

In no event shall Diamond Products be liable for consequential or incidental damages arising out of the failure of any Product to operate properly.

Integral units such as engines, electric motors, batteries, transmissions, etc., are excluded from this Warranty and are subject to the prime manufacturer's warranty.

THIS WARRANTY IS IN LIEU OF ALL OTHER WARRANTIES, EXPRESSED OR IMPLIED, AND ALL SUCH OTHER WARRANTIES ARE HEREBY DISCLAIMED.



333 Prospect Street, Elyria, Ohio 44035
(440) 323-4616 • (800) 321-5336 • Fax (440) 323-8689
www.diamondproducts.com