

A-202

Pulse Vac



**3706 Mill Creek Drive NE
Comstock Park, MI 49321
VOICE: (616) 447-9076
FAX: (616) 447-9078
E-mail: info@bwmanufacturing.com
www.bwmanufacturing.com**

Version 09/2014

Part# W-0028

INTRODUCTION

FORWARD

WARNING READ THIS MANUAL CAREFULLY PRIOR TO OPERATING THE EQUIPMENT IN ORDER TO UNDERSTAND HOW TO OPERATE AND SERVICE THE EQUIPMENT CORRECTLY. FAILURE TO PROPERLY REVIEW THIS MANUAL COULD RESULT IN PERSONAL INJURY OR EQUIPMENT DAMAGE.

This manual should be considered a permanent part of the equipment and should remain with the equipment at all times. Please note the following:

Measurements in this manual are given in metric and standard U.S. measurement equivalents.

Use only correct replacement parts and fasteners. Fasteners may require specific tools.

Right and left hand sides are determined by facing forward while sitting in the seat behind the steering wheel.

THIRD-PARTY MANUFACTURER INFORMATION

This equipment contains an engine manufactured by a third-party manufacturer. This engine may be covered by the manufacturer's standard factory warranty and the manufacturer may require that all repairs and/or service be completed pursuant to its warranty terms and conditions. Please refer to the product manual and Warranty Breakdown for additional information on this warranty and any registration requirements.

TERMS AND CONDITIONS OF SALE

1. **Parties.** "Seller" means **BW Manufacturing, Inc.** "Buyer" means any entity or individual purchasing goods from Seller.
2. **Terms and Conditions of Sale.** These Terms and Conditions of Sale define the relationship of Buyer and Seller and apply to all sales of equipment (including, but not limited to Shotblasters, Scarifiers, Diamond Grinders/Polishers, Concrete Dust Collection Systems, and Trailers), components incorporated into equipment, parts, supplies, materials or other personal property (individually and collectively, "Equipment") by Seller to Buyer. Buyer acknowledges and agrees that these Terms and Conditions of Sale are incorporated in, and are a part of, any contract of sale and each quotation, purchase order, invoice, and any other document relating to the sale of Equipment by Seller to Buyer (these documents are collectively referred to as the "Agreement").
3. **Quotation Expiration.** Written quotations signed by Seller are valid for a period of 30 days unless otherwise noted by Seller.
4. **Pricing.** Prices for Equipment and other related information shown in any Seller product publication, including but not limited to catalogs, brochures, and websites, are subject to change without notice. Prices do not include related freight charges, use tax, sales tax, excise tax, value-added tax, or similar taxes, or charges of any nature whatsoever imposed by any governmental authority unless otherwise expressly noted by Seller.
5. **Taxes.** Prices quoted do not include (and Buyer shall pay) all taxes and fees of any kind that may be levied or imposed on either party by federal, state, municipal, or other governmental authorities in connection with the sale or delivery of the Equipment by Seller.
6. **Terms of Payment.** Unless Buyer has obtained credit approval from Seller, payment is due and payable to Seller in cash on completion of Seller's delivery obligation (COD). For Buyers with credit approval, any amounts due by Buyer to Seller that are unpaid on or after 30 days of Seller's invoice will bear interest at the simple interest rate of 2 percent (2%) per month or the maximum rate permitted by law, whichever is less. The accrual or payment of any interest as provided above will not constitute a waiver by Seller of any rights and remedies in connection with a default by Buyer. Buyer will pay all court costs, attorney fees, and other costs incurred by Seller in collecting past-due amounts, including interest. If shipment or delivery of Equipment is delayed by or at the request of Buyer, payment will remain due in full on the original delivery date for Buyers without credit approval or 30 days from the date of Seller's invoice for Buyers with credit approval. In either such event, Seller may impose, and Buyer shall pay, storage charges and other incidental expenses incurred by Seller as a result of the delay in addition to any interest on late payments as described above.
7. **Security Interest.** As security for payment of all amounts due to Seller, Buyer grants to Seller a security interest in all Equipment sold by Seller to Buyer, and Seller will have all rights of a secured party under the Uniform Commercial Code with respect to the Equipment. Buyer appoints Seller as its attorney-in-fact with authority, at Seller's option, to take actions as Seller deems reasonable in the circumstance to perfect the above security interest in any one or more jurisdictions, and Buyer shall pay all applicable filing fees.
8. **Limited Express Warranty.** For a period of ninety (90) days from the completion of Seller's delivery obligation under this Agreement, Seller warrants that a limited selection of components manufactured by Seller and incorporated into the Equipment will be free of defects in material and workmanship. A complete list of components covered under this warranty ("Warranty Breakdown") is available at www.bwmanufacturing.com/warrantybreakdown and is incorporated in its entirety into this Agreement. In the event Buyer has a claim related to the components covered under this warranty, Buyer shall be bound by the then-current Warranty Breakdown. Buyer's sole remedy for breach of this warranty is limited to repair and replacement, within the warranty period, of defective components manufactured by Seller and covered under this warranty pursuant to the Warranty Breakdown. Buyer is responsible for all shipping costs arising out of any warranty service provided by Seller. SELLER EXPRESSLY DISCLAIMS AND EXCLUDES ALL OTHER WARRANTIES, EXPRESS OR IMPLIED, WITH REGARDS TO THE EQUIPMENT AND/OR COMPONENTS MANUFACTURED BY SELLER AND INCORPORATED INTO THE EQUIPMENT, WHICH ARE NOT INCLUDED IN THE ABOVE REFERENCED WARRANTY, INCLUDING THE WARRANTIES OF MERCHANTABILITY AND FITNESS FOR A PARTICULAR PURPOSE. BUYER ASSUMES FULL RESPONSIBILITY THAT THE EQUIPMENT PURCHASED UNDER THE AGREEMENT MEETS THE SPECIFICATIONS AND/OR INTENDED USE OF BUYER, AND SELLER MAKES NO REPRESENTATION WITH RESPECT THERETO.
9. **Disclaimer of Third-Party Component Warranties.** THE SOLE REMEDY AVAILABLE TO BUYER WITH RESPECT TO DEFECTS IN THE COMPONENTS MANUFACTURED BY THIRD PARTIES WILL BE AGAINST THE THIRD PARTY MANUFACTURER UNDER ANY APPLICABLE MANUFACTURER'S WARRANTY TO THE EXTENT AVAILABLE TO BUYER. WITH REGARDS TO COMPONENTS MANUFACTURED BY THIRD PARTIES AND INCORPORATED INTO THE EQUIPMENT, SELLER MAKES NO WARRANTY, EXPRESS OR IMPLIED, RELATING TO THE COMPONENTS, WHETHER BASED ON BREACH OF WARRANTY OR CONTRACT, NEGLIGENCE, STRICT LIABILITY OR OTHERWISE, INCLUDING WITHOUT LIMITATION ANY IMPLIED WARRANTIES OF MERCHANTABILITY OR FITNESS FOR A PARTICULAR PURPOSE.

10. **No Consequential Damages.** IN NO EVENT WILL SELLER BE LIABLE OR RESPONSIBLE FOR ANY SPECIAL, INCIDENTAL, CONSEQUENTIAL, EXEMPLARY, OR PUNITIVE DAMAGES, OR FOR EXPENSE OCCASIONED BY THE USE OF DEFECTIVE EQUIPMENT.

11. **Delivery.** Any delivery dates or other schedule of performance by Seller are approximations, and the sole obligation of Seller with respect to the schedule of delivery or performance will be to use commercially reasonable efforts to deliver the Equipment, or otherwise to perform, consistent with the reasonable demands of its business. In any event, Seller will have no liability to Buyer or any other person for delays in performance due to strikes or labor disputes of any type; accidents, fire, floods, acts of God, or actions by governmental authorities; acts, omissions, or delays of Buyer or any other third party; shortages of labor; or without limitation of the above, for any causes reasonably beyond the control of Seller.

12. **Title and Risk of Loss.** Title to and risk of loss to the Equipment will pass to Buyer on delivery by Seller F.O.B. Seller's place of business, located at 3706 Mill Creek Dr. NE, Comstock Park, Michigan, 49321.

13. **Inspection and Acceptance.** Buyer will have two (2) days from the date of delivery to inspect the Equipment for defects and nonconformance and to notify Seller, in writing, of any defects, nonconformance, or rejection of the Equipment. After this period, Buyer will be deemed to have irrevocably accepted the Equipment. After acceptance, Buyer will have no right to reject the Equipment for any reason or to revoke acceptance. Seller is not responsible for damage to the Equipment arising out of the shipment of the Equipment to Buyer. Claims for damage due to shipping must be made by Buyer to the freight carrier.

14. **Return of Equipment.** All returns will be pursuant to Seller's instructions. Buyer must contact Seller for a Return Material Authorization (RMA) before returning any Equipment. All returns must reference the RMA number along with the original invoice number and the reason for return.

15. **Cancellation or Termination.** In the event of cancellation of the Agreement by Buyer, or in the event of default under the Agreement by Buyer that is not cured within 30 days after notice by Seller, Buyer will pay to Seller on demand all direct and indirect costs (including, without limitation, all applicable restocking or cancellation charges, including reimbursement for direct costs assessed by the manufacturer) incurred directly or indirectly by Seller in connection with the Agreement, all as reasonably determined by Seller, plus any lost profit. In no event, however, will any amount payable by Buyer under the Agreement exceed the total price payable by Buyer for the Equipment.

16. **Modifications and Waiver—Entire Agreement.** The Agreement contains the entire agreement between Seller and Buyer and can be modified or rescinded only by a writing signed by both parties. If any term of the Agreement is held invalid or unenforceable, all other terms of the Agreement shall remain in effect. Any document submitted by Buyer to Seller confirming its intention to purchase Equipment described in the Agreement will be deemed to constitute a confirmation and acceptance of the Agreement, even if the document states terms in addition to or different from those in the Agreement. All agreements between Seller and Buyer will be solely under the terms and conditions of the Agreement and Seller objects to any and all additional or different terms contained in any document submitted to Seller by Buyer. Any execution by Seller of any other document submitted by Buyer in connection with the purchase of Equipment does not constitute acceptance of or agreement to any terms and conditions in addition to or different from those contained in the Agreement, but will constitute only acknowledgment of receipt of the document. In addition, Buyer's acceptance of these terms shall be conclusively presumed by Buyer's (i) acceptance of delivery of or (ii) payment for Equipment covered under the Agreement.

17. **Compliance with Laws.** Buyer will be responsible for compliance with any and all federal, state, or local laws or regulations respecting safety or respecting use of the Equipment and shall indemnify and hold Seller harmless from and against any and all claims of violations of laws or regulations or other claims of personal injury or property damage directly or indirectly related to the installation, maintenance, or operation of the Equipment.

18. **Export Control.** Equipment supplied by Seller may be subject to various export laws and regulations. It is the responsibility of the exporter and Buyer to comply with all laws and regulations. If any required export authorization is denied, Seller will be relieved of any further obligation related to the sale and delivery of the Equipment.

19. **Governing Law and Venue.** This Agreement will be governed by and construed in accordance with the laws of the State of Michigan. Buyer submits to personal jurisdiction in Michigan. Seller and Buyer agree that any action arising out of the sale of goods or services in accordance with this document will be brought, heard, and decided in a court located in Kent County, Michigan and that this venue is convenient. .

20. **Authority.** Each signatory represents that it has all requisite authority to execute the Agreement on behalf of its principal and that the Agreement is fully enforceable against the principal in accordance with its terms.

B W MANUFACTURING, INC.

GENERAL SAFETY & HAZARDOUS MATERIALS WARNING

WARNING SURFACE PREPARATION EQUIPMENT CAN BE DANGEROUS IF NOT OPERATED PROPERLY. THE OPERATOR IS RESPONSIBLE FOR THE SAFE OPERATION OF THIS EQUIPMENT. The operator must carefully read and follow any warnings or safety instructions provided with the equipment prior to operating the equipment. Do not remove any safety devices or warnings on the equipment.

WARNING FLOOR AND/OR DECK SURFACES MAY BE COATED WITH OR CONTAMINATED BY HAZARDOUS MATERIALS. Typical examples of hazardous materials include (i) tile mastic (likely to contain *asbestos*); (ii) stained areas near electrical equipment (potentially containing *PCBS*); (iii) paint (potentially containing *lead*); (iv) stained floor areas in chemical or other industrial facilities (potentially containing toxic *pesticides, cleaning fluids, solvents, or other harmful chemicals*).

WARNING Preparation equipment is used to remove surface material from a variety of surfaces. The surface preparation process often generates large amounts of dust and other small particles, which are released into the air. WHEN A SURFACE CONTAINS HAZARDOUS MATERIALS, EXPOSURE TO THE DUST GENERATED BY THE PREPARATION EQUIPMENT MAY POSE A HEALTH RISK. INSPECT ALL SURFACES FOR POSSIBLE CONTAMINATES PRIOR TO USING PREPARATION EQUIPMENT AND CONSULT HAZARDOUS MATERIAL EXPERTS AND GOVERNMENT AUTHORITIES BEFORE OPERATING PREPARATION EQUIPMENT ON SURFACES SUSPECTED OF CONTAINING HAZARDOUS MATERIALS.

WARNING BW MANUFACTURING, INC. IN NO WAY REPRESENTS THAT ITS PREPARATION EQUIPMENT IS SUITABLE OR APPROVED FOR REMOVING HAZARDOUS MATERIALS FROM CONTAMINATED SURFACES. DO NOT ATTEMPT TO USE ANY PREPARATION EQUIPMENT MANUFACTURED BY BW MANUFACTURING, INC. ON ANY CONTAMINATED SURFACE. It is the responsibility of the preparation equipment operator and/or the contractor using the preparation equipment to inspect the proposed worksite for contaminants and obtain approval from contamination experts and/or government authorities before using BW Manufacturing, Inc. preparation equipment. It is also the responsibility of any contractor using preparation equipment to inform its employees or subcontractors of all potential health risks associated with operating preparation equipment and to ensure its employees or subcontractors are protected from exposure to harmful materials.

BW MANUFACTURING, INC. IS NOT RESPONSIBLE FOR ANY INJURY, ILLNESS, DEATH, OR PROPERTY DAMAGE THAT MAY RESULT FROM IMPROPER USE OF ITS PREPARATION EQUIPMENT OR OTHER PRODUCTS

B W MANUFACTURING, INC.

NEW FILTER APPLICATIONS

New filters will flow noticeable dust for the first 10 to 15 minutes of use or until the filter is adequately coated with material. The filter cleans to 99.950 efficiency at 2 microns and therefore the filter will allow a minimal amount of dust through the filter on every pulsation cycle even after filter is fully loaded.

Further tests have shown that humidity and concrete dampness will affect the efficiency of the pulsation system to clean the filter.

- Stock filter included with A-202 Pulse Vac is part #10129-B
- Optional filter is a Moisture Resistant “Duct Back” Filter part # 10129-D
- Optional filter is a HEPA filter part # 10129-H (*Special Order*)



10129-B

Filter (Blend) (*Standard*)
99.7% Efficiency @ .05 Microns

10129-D

Moisture Resistant (*Optional*)
99% Efficiency @ 1-2 Microns

10129-H

HEPA (*Special Order*)
99.995% Efficiency @ .03 Microns

WARRANTY BREAKDOWN

Item	NONE	90 DAYS	1YEAR	2 YEARS	WARRANTED BY:
Chassis			○		B W Mfg., Inc.
Engine (gas)			○		Honda Power
Engine (gas)				○	Subaru Robin
Engine (220V)			○		Leeson Elect.
Compressor			○		B W Mfg., Inc.
Dust Filters	○				B W Mfg., Inc.

WARRANTY CONTACT INFORMATION

B W Mfg., Inc.	B W Manufacturing, Inc.
	Voice: 616-447-9076
	Fax: 616-447-9078
	E-mail: info@bwmanufacturing.com
	<i>Warranty does not include travel time</i>
Subaru Robin	Subaru Robin
	940 Lively Blvd.
	Wood Dale, IL 60191-1204
	Phone: 800-277-6246
	<i>E-mail: website.warranty@robinamerica.com</i>
Honda Power Equipment Group	Honda Power Equip. Group
	4900 Marconi Dr.
	Alpharetta, GA 30005-8847
	Phone: 770-497-6400
	<i>Website: www.honda-engines.com</i>
Leeson Elect.	Leeson Electric Corp.
	2100 Washington Street
	P.O. Box 241
	Grafton, WI 53024-0241
	Phone: 262-377-8810
	E-mail: leeson@leeson.com

A-202 PULSE VAC OPERATING & MAINTENANCE INSTRUCTIONS

Starting Instructions For Models Equipped With A Gas Engine

Begin by turning the gas valve to the OPEN position (1), then place the power switch in the ON position (2), adjusting the choke (3), place throttle in wide open position (4), and pull the starting handle (5 *not shown*). As motor begins to run you will need to adjust the choke (3) until the engine runs smoothly.

To turn off engine, start by placing the power switch (2) in the OFF position, and return the gas valve (1) to the CLOSE position.

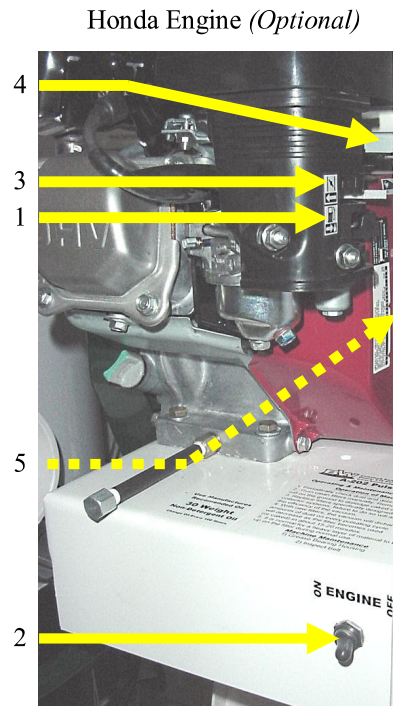
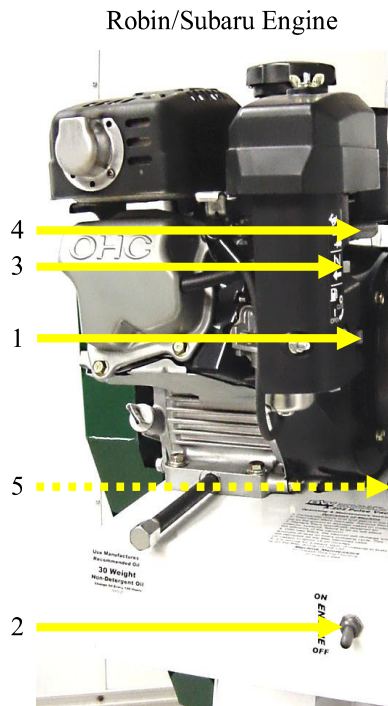

Gas Engine Maintenance Instructions

Clean engine air filter every day
Change engine oil after first 20 hours of operation and every 100 afterward.

Starting Instructions For Models Equipped With An Electric Engine

220V Single Phase

Plug unit into a 220 volt, 30 amp service and turn on machine using ON/OFF Switch (6).

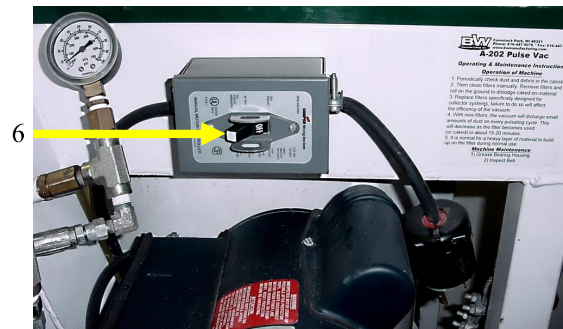

A-202 PULSE VAC OPERATING & MAINTENANCE INSTRUCTIONS

Greasing The Blower Bearing Housing

Grease every 8 hours (A)

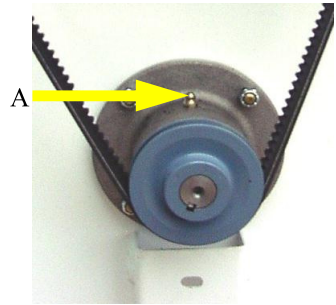

Filter Inspection & Maintenance

Routine inspection of filters (B)

To Clean Filter Manually:

Rotate the filter and gently tap the filter sides on the ground. Adverse conditions on the filters such as heavy grease, oil, glues, and moisture may require more frequent manual cleaning or replacement.

*(Using filters that are **not designed** for collector systems will cause a decrease in vacuum and will reduce paddle and liner life).*

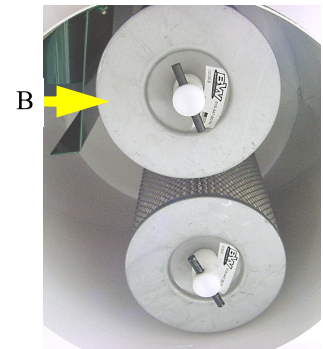

Generation 1

Unloader Valve Settings

Valve #1 is set at 80 PSI (C)

Valve #2 is set at 70 PSI (D)

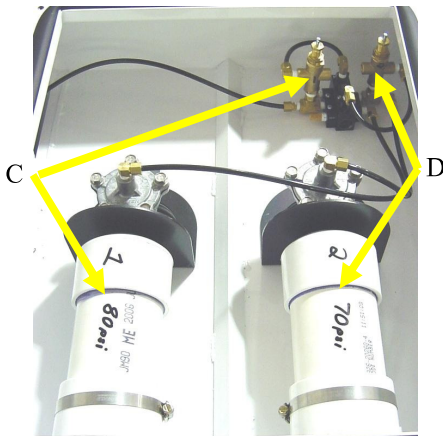

Generation 2

Unloader Valve Settings

Valve #1 is preset at factory (E)

Valve #2 is preset at factory (F)

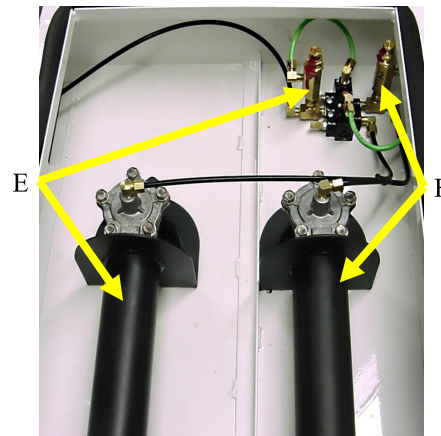

Gas Engine & Air Compressor Maintenance

Using manufactures recommended oil (30 Weight Non-Detergent Oil) changing every 100 hours of operation (G).

Check compressor air filter (H) and engine air filter (I) every 8 hours of operation.



A-202 PULSE VAC OPERATING & MAINTENANCE INSTRUCTIONS

Dust Drum Removal and Installation

To remove drum for emptying, start by turning the winch handle counter clockwise (1) to lower the drum. Once there is slack in the cable, unhook the pulley (2) from either side of the drum and push chassis of vacuum back. Once drum is clear of the chassis it is ready to be emptied of debris and dust.

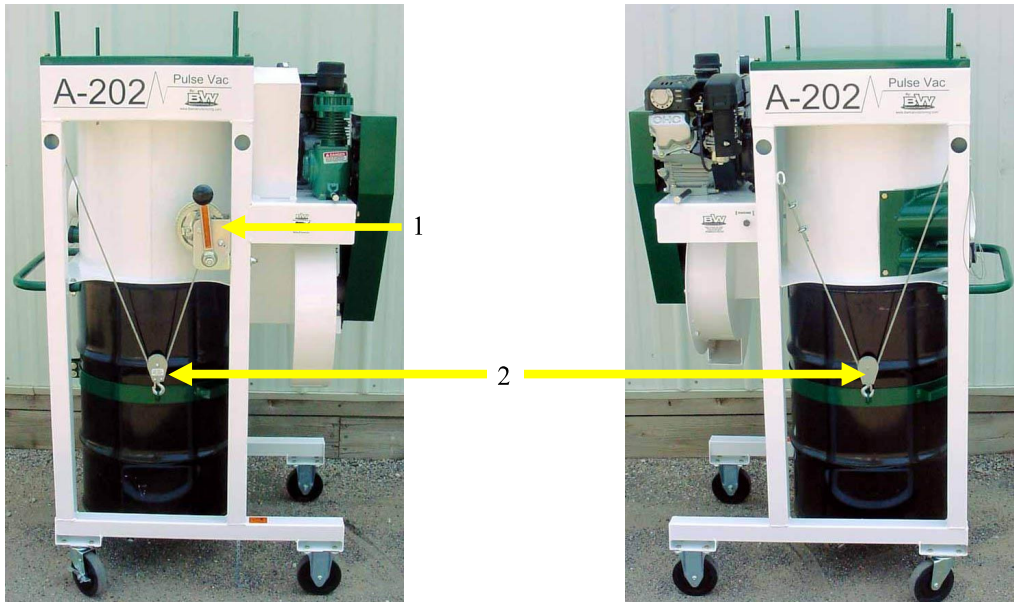

A-202 PULSE VAC PARTS

- 1. W-36-AS Belt Guard
- 2. A-8578 Engine (Gas/Robin-Subaru)
A-8607 Motor 220V (Electric - *Not Shown*)
- 3. B-1647 Wire Rope Clip
- 4. W-23-AS Collector Lid
- 5. W-31-AS Intake Assembly
- 6. W-0017 Caster (Stationary)
- 7. W-0019 Caster (Swivel)



Dia. A-202-1

- 1. I-130 Winch
- 2. W-06-AS Collector Body
- 3. W-0001-AS Drum Assembly
- 4. I-143 Pulley W/Hook
- 5. W-35 Handle

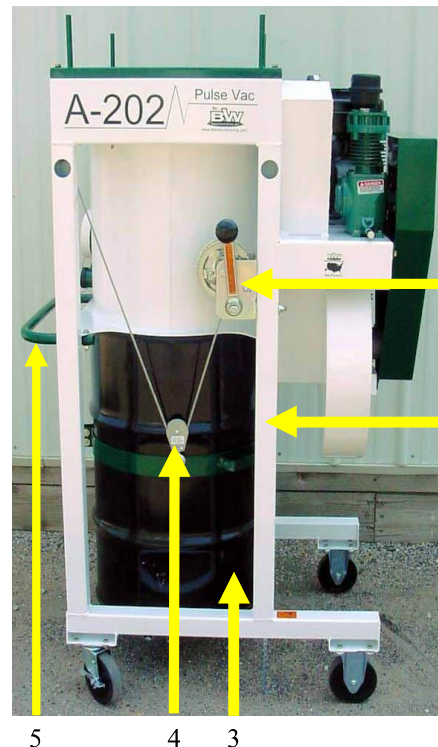

Dia. A-202-2

A-202 PULSE VAC PARTS

- 1. W-0023 Pulley
- 2. W-31-AS Intake Pipe
- 3. I-147-AS Cap 5"
- 4. W-0016 Cap 2"
- 5. I-163 Lanyard
- 6. W-27-AS Drum Strap
- 7. W-49 Lid seal (*not shown*)
- 8. W-50 Drum deal (*not shown*)

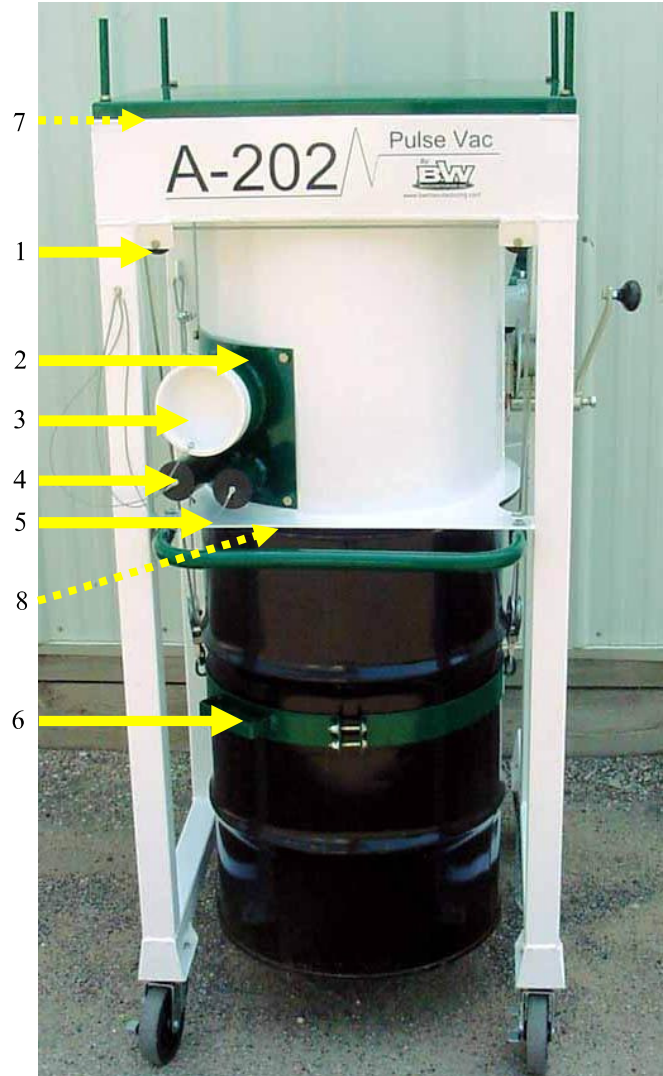

Dia. A-202-3

- 1. W-34-AS Dust Deflector
- 2. 10129-B Filter (blend)
- 10129-D Filter (moisture resistant) (optional)
- 10129-H Filter (HEPA) (optional - *special order*)
- 3. V-122-AS Filter Nut

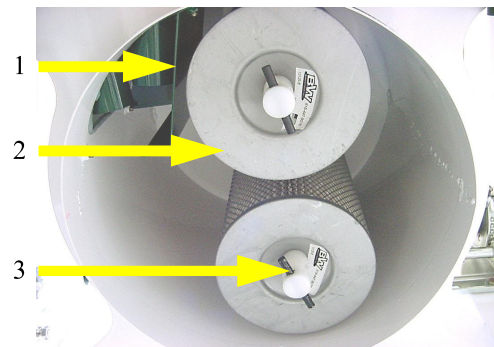

Dia. A-202-4

A-202 PULSE VAC PARTS

1. W-02-AS Air Tank (*DISCONTINUED*)
2. W-18-AS Air Tank Mount (*DISCONTINUED*)
3. W-52 Popet Valve
4. V-1031 Air Fitting (90 deg.)

Generation 1

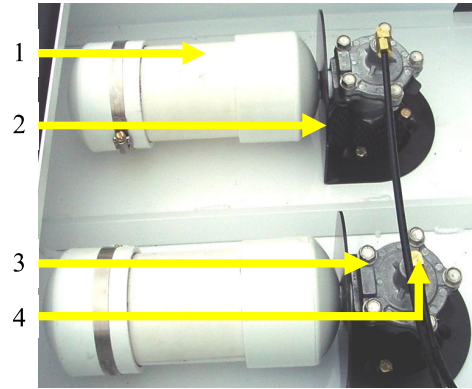

Dia. A-202-5

1. W-18-1AS Air Tank Mount
2. W-52 Popet Valve
3. V-1031 Air Fitting (90 deg.)

Generation 2

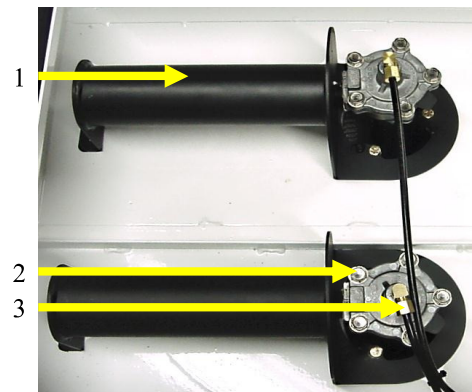

Dia. A-202-6

1. V-1019 Orifice Bushing
2. W-52 Popet Valve
3. W-53 Popet Valve Repair Kit

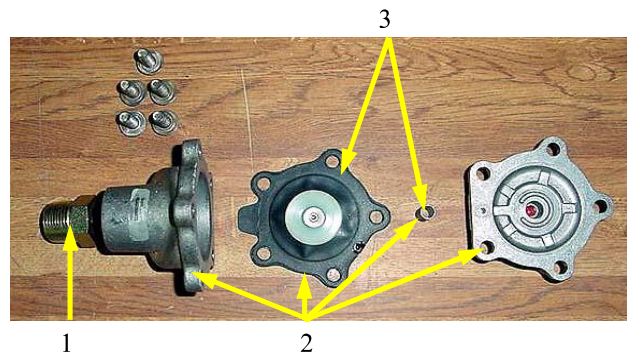

Dia. A-202-7

Generation 1

1. W-0009 Unloader Valve
(please verify which pressure setting you need)
2. W-0008 Pilot Valve

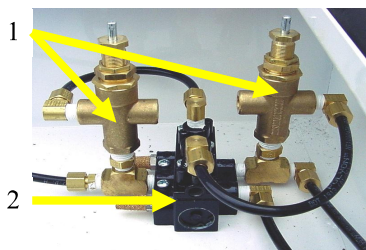

Generation 2

1. W-0031 Low Pressure Unloader Valve
2. W-0032 High Pressure Unloader Valve
3. W-0008 Pilot Valve

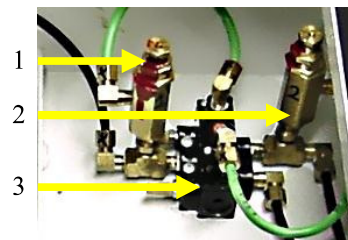

Dia. A-202-8

Unit can be purchased as an assembly using part number **W-0008-AS**

A-202 PULSE VAC PARTS

- 1. I-127 Motor Sheave (Gas)
- R-117 Motor Sheave (220V)
- 2. I-126 Idler Pulley
- 3. D-1311 Belt Tensioner
- 4. W-0027 Belt
- 5. I-128-A Blower Sheave
- 6. W-37-AS Blower Mount

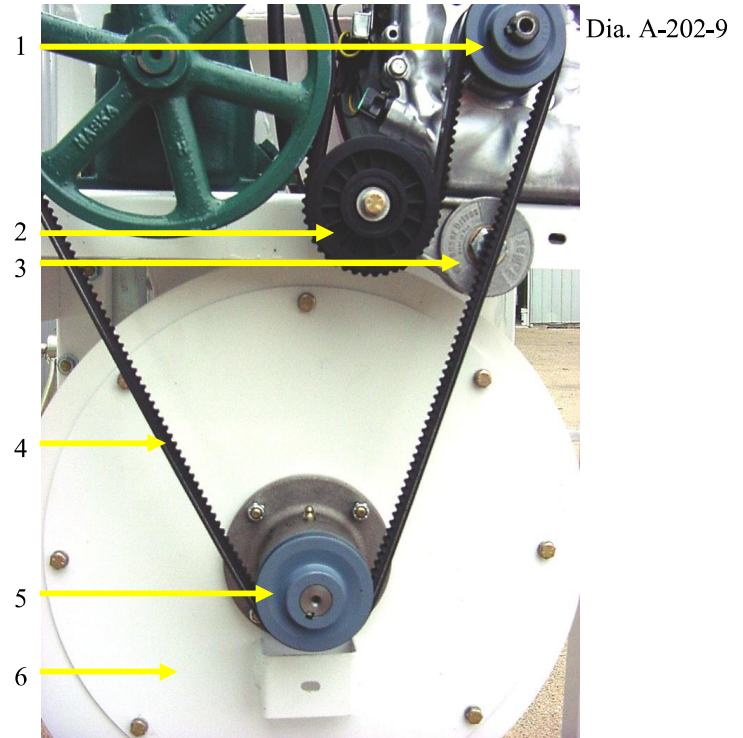

- 1. D-1205 Blower Fan
- 2. 1/4-20X1 Blower Fan Bolt
- 3. R-36 Blower Hub
- 4. D-1290 Blower Fan Bearing
- 5. D-1309 Blower Fan Main Shaft Snap Ring
- 6. O-02-V Blower Fan Main Shaft

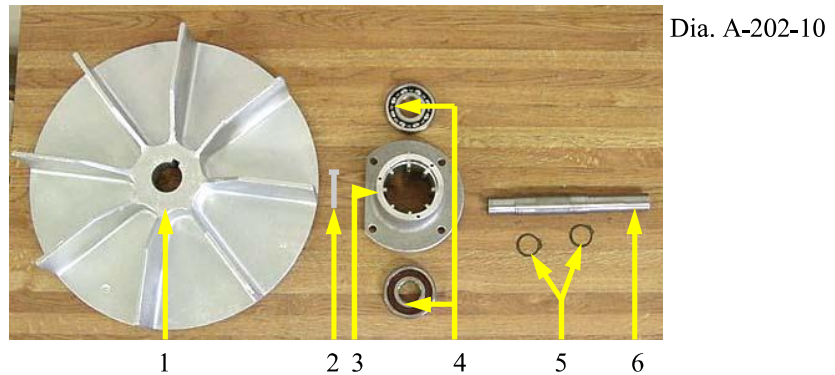

A-202 PULSE VAC PARTS

- 1. M-05 Air Compressor
- 2. A-8578 Gas Engine (*Robin/Subaru*)
- 3. I-144-FE Compressor Air Filter
- 4. I-157 Engine Air Filter & Foam Pre-Filter (*Robin/Subaru*)

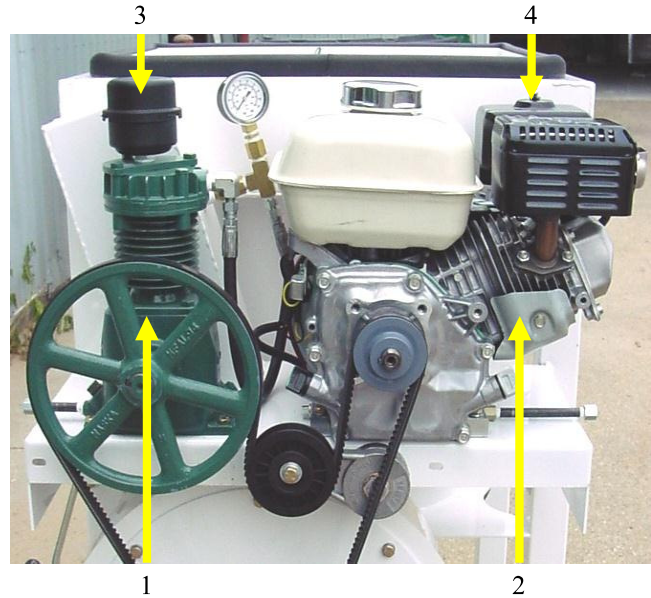

Dia. A-202-11

- 1. V-1022 Pressure Gauge
- 2. I-106 Fitting
- 3. I-154 Snubber
- 4. I-154-B Snubber Filter
- 5. C-1645 Adapter
- 6. I-158 Unloader Valve
- 7. C-1764 Adapter

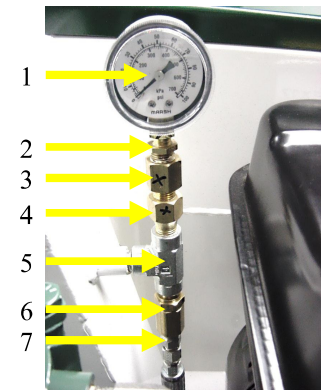

Dia. A-202-12

- 1. C-1776 Compressor Fitting
- 2. W-59 Air Compressor Air Line

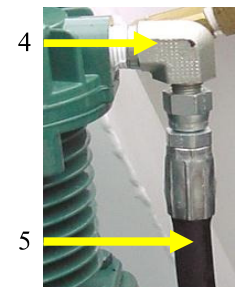

Dia. A-202-13

- 1. V-1018 Brass Nipple
- 2. W-0006 Adapter
- 3. C-1623 Pressure Relief Valve
- 4. V-1031 Fitting (90 Degree)

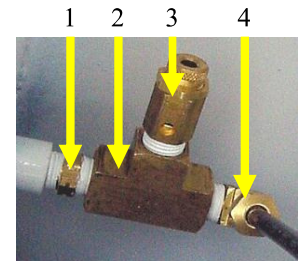

Dia. A-202-14

A-202 PULSE VAC PARTS



I-122
5" x 15' Vac Hose



V-1084
2" x 15' Vac Hose



10129-B
Filter (Blend) (Standard)
99.7% Efficiency @ .05 Microns

10129-D
Moisture Resistant (Optional)
99% Efficiency @ 1-2 Microns

10129-H
HEPA (*Special Order*)
99.995% Efficiency @ .03 Microns



W-0002
30 Gallon Drum Liner (4 mil)

A-202 PULSE VAC

Page
Left
Intentionally
Blank