



COMP cooler

Personal Thermal Regulation Technology
To Keep Your Body Cool and Comfortable in Harsh Conditions!

On line Shopping



www.compcooler.shop

simonsun@compcooler.com

Designed in USA
Made in China

Motorcycle Rider Solo Ice Chest Cooler System

Model: COMP-BMCS-746L

Operation Manual

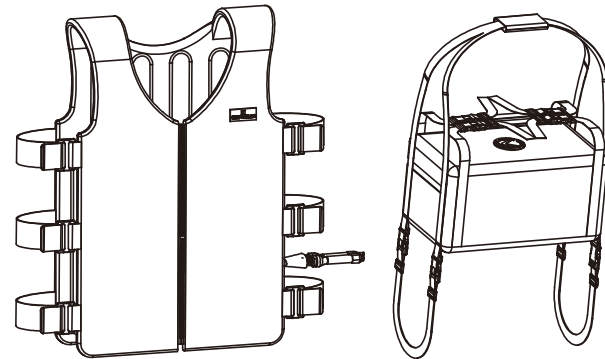

COMP cooler

PERSONAL THERMAL TECHNOLOGY

COMPCOOLER

Personal Thermal Technology

Personal Liquid Circulation Cooling System

- Liquid Cooling Garment
- ICE Water Cooling Unit
- Mini Chiller Cooling Unit

Reduce body core temperature and decrease the incidence of thermal stress while increase comfort, safety, focus and endurance.

Contents

System Description.....	1
Components.....	2
Component Description.....	3
Performance.....	4
Garment Sizing.....	4
System Preparation.....	5-6
System Operation.....	6-7
Maintenance.....	7
Storage.....	7
Optional Components.....	8
Safety.....	8
Warranty.....	8
Certifications.....	8

System Description:

The Compcooler ICE Chest Cooling System combines a tubing-lined vest with a liquid cooling system housed in a ice chest to form a tethered thermal regulation device. Although this cooling system is highly transportable, it is designed for use in stationary applications whereby the ice chest is located away from the User's person but connected with tubing.

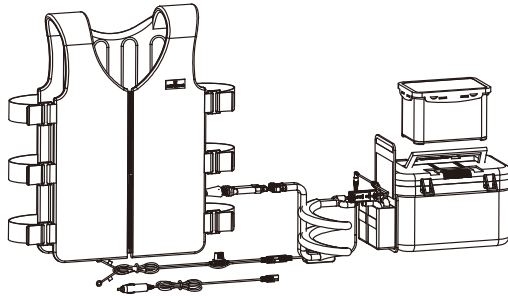

The vest is a highly engineered breathable mesh garment that weighs a mere 0.5KG (1.1 lbs.), dry weight. It consists of a soft mesh outer fabric and inner liner which is easy to don and comfortable to wear against the body. A zipper and adjustable tabs provide a snug fit for maximum thermal transfer. The liquid cooling system is a separate ice chest that weighs 1.5KG (3.3 lbs.), dry weight. It contains a 3.0-liter removable ice container, circulation pump, power source, and power switch. When operating, it's audible output is 45dBA.

Cooling energy is provided by freezing the water in the ice container. This is easily accomplished by removing the 3.0L container from the ice chest, filling it with water and then placing the container in a freezer. Once frozen, the container is easily replaced in the ice chest and connected to the cooling system's pump using quick-connect fittings. Power is derived from either a 7.4V battery pack, a 12VDC adapter (to run off vehicle power) or 110-220VAC adapter. Users turn the switch on and the pump circulates cold water in a continuous loop between the ice chest and vest. Users can expect a cooling duration anywhere from 3 to 4 hours depending on ambient temperatures and workload.

Additional ice containers and battery packs can be purchased for prolonged cooling. A flow control pump for regulating the cooling temperature is also available as an option to the standard On/Off pump.

Components List

COMP-BMCS-746L-NF (On/Off Operation)

Item	Description	Quantity
1	Liquid cooling vest	1
2	Ice chest, 6.0L	1
3	3.0L ice container	1
4	Soft pack with straps; houses the ice chest	1
5	Water pump, simple ON/OFF operation	1
6	Extension tubing, 3ft	1
7	7.4V power adapter, 12VDC or 110-220VAC	1
8	Manual	1
	Rechargeable battery 7.4V 2200mAh and charger	Optional

COMP-BMCS-746L-FC (Flow Control Operation)

Item	Description	Quantity
1	Liquid cooling vest	1
2	Ice chest, 6.0L	1
3	3.0L ice container	1
4	Soft pack with straps; houses the ice chest	
4	Water pump, flow control operation	1
5	Extension tubing, 3ft	1
6	7.4V power adapter, 12VDC or 110-220VAC	1
7	Manual	1
	Rechargeable battery 7.4V 2200mAh and charger	Optional

Component Description

Liquid Cooling Vest:

1. Outer Fabric; Soft stretch mesh
2. Liner; Soft stretch mesh
3. Cooling Channel; Silicone micro-tubing
4. Front Zipper
5. Adjustable tabs
6. Aluminum manifold
7. Male quick-connect fittings

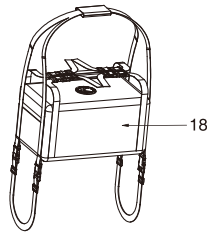
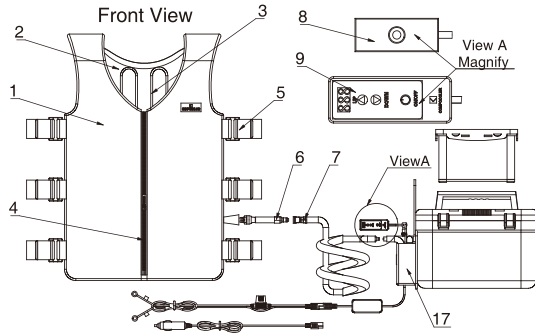

Back View

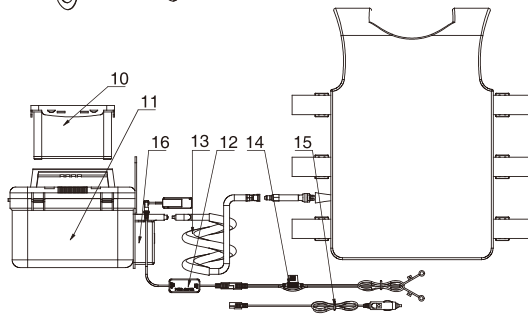

Ice Chest Circulation System:

8. Power Switch: simple ON/Off operation
9. Flow Controller (Optional)
10. 3.0L Container
11. 6.0L Ice Chest
12. 7.4V to 12V Adapter
13. Extension tubing
14. Battery Tender 12VDC with 5.0A Fuse
15. Car cigar power cable 12VDC with 5.0A fuse
16. 7.4V pump, 500ml/min
17. Soft pump pack
18. Soft Chest pack with straps

Performance:

Combined Vest and Backpack

- Cooling time:
 - 3-4 hours with 6.0L chest
 - 8-10 hours with 25.0L chest
- Circulation: 500ml/min
- Temperature range: 2° - 10°C (36 - 50°F)
- Operation ambient: 0 - 65°C (32 - 149°F)

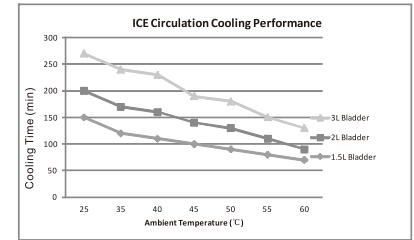

Rechargeable battery, 7.4V 2.2A

- Battery life: 8 hours
- Charging time: 3-5 hours

Rechargeable battery, 7.4V 5A

- Battery life: 20 hours
- Charging time: 4-5 hours

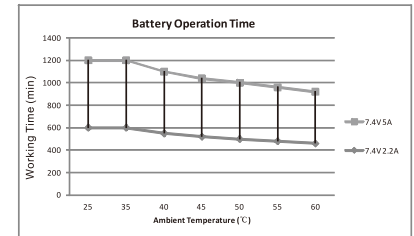

Garment Sizes

Garment can expand 15% (max 15cm/6") with adjustable tabs.

Feature	XS/S	M/L	XL/XXL	3XL/4XL
Chest	84cm/33.1"	100cm/39.4"	108cm/42.5"	126cm/49.6"
Length	64cm/25.2"	68cm/26.8"	70cm/27.6"	73cm/28.8"



System Preparation

1. Power:

1.1 12VDC Power Supply: First connect the wire assembly to the power source using either of the options shown below. Route and secure the wire assembly in a manner that prevents damage from heat or snagging.

Connect the SAE plug of the wire assembly to the mating SAE plug of the Power Adapter. Leave enough length on the 4017 DC plug end such that it can be connected to the ice chest.

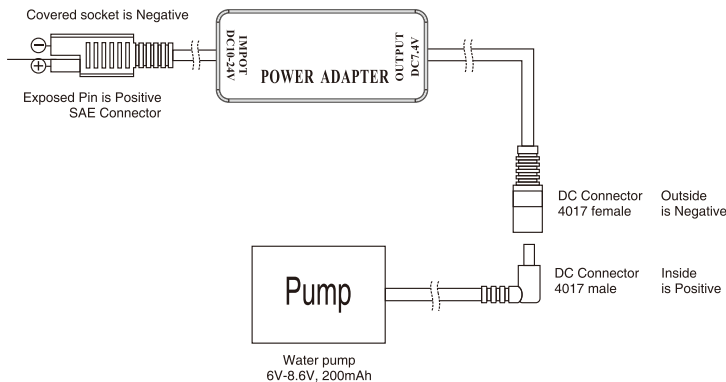
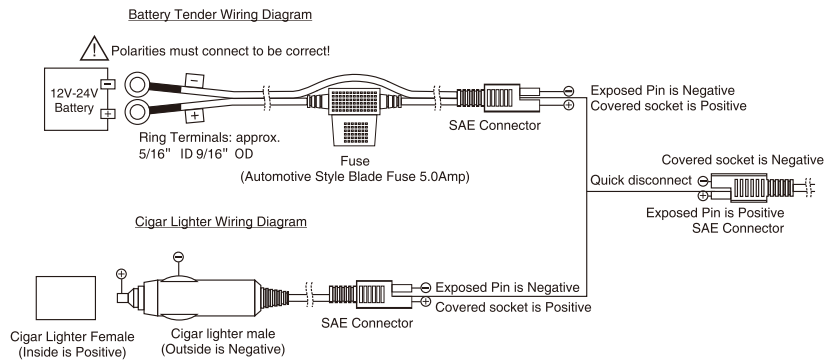

1.2 Rechargeable Battery (if purchased): Charge the battery using the included charging cord. LED lights on the battery housing indicate charging progress. A red light indicates the battery is still charging. A green light indicates the battery is fully charged. Reference Figure (A).

Pressing “Remaining Battery Capacity” on the battery indicates, by percentage, how full the battery is. 3 Led lights indicate 80-100% capacity, 2 lights indicate 60-80% capacity and 1 light indicate $\leq 50\%$ capacity. Reference illustration at right.

Typical charge time to ‘full’ is 4 hours. A fully charged battery will operate up to 8 hours.



2. Ice Container:

Open the 3.0L container and fill it with water.

Place the water-filled container in a freezer and allow the water to completely freeze for optimum performance. Note: Ice cubes can also be used if there is not enough time to wait for a frozen container. In this case, add ice cubes to the cooler and top off with water. While ice cubes will provide adequate performance, the cooling time will be reduced.

3. Mount the Ice Chest and Extension Tubing:

Place the ice chest in the soft pack and close it shut. Secure the soft pack in place (ie: on the motorcycle) using the attached straps. Secure the extension tubes using the attached Velcro straps in a manner that prevents damage from heat or snagging. The extension tubes should be positioned such that there is adequate length to connect to both the pump (on the ice chest) and the vest.

System Operation

- 1. Install ice container;** Open the lids of both the soft pack and the empty ice chest. Place the frozen 3.0L container in the ice chest and then top off the ice chest with 1000ml (1.0 qt.) water. Close the lids to the ice chest and soft pack.
- 2. Power connection;** connect the plug from the power source (ie: battery or 12VDC source) to the pump.
- 3. System check;** before donning, connect the tubes on the vest to the tubes on the ice chest using the quick-connect fittings. An audible ‘click’ of the quick-connect fittings ensures a proper connection. Note: orientation of the tubes does not matter. Turn the system ‘On’ using the On/Off switch. An audible sound of the pump and visual inspection of flowing water near the inlet fitting are initial signs of a properly operating system. At this point check the pump and quick-connect fittings for leaks. Any leaks must be remedied before donning the system. After performing the system check, disconnect the vest from the pump using the quick-connect fittings.

4. **Don the vest;** Once donned, zip the vest and adjust the tabs to create a snug fit. For optimal cooling performance, wear the vest against bare skin.
5. **Connect vest to ice chest;** connect the tubes on the vest to the tubes on the ice chest using the quick-connect fittings. An audible 'click' of the quick-connect fittings ensures a proper connection.
6. **Start cooling;** Press the On/Off switch located on the left breast to start the cold water circulation. Press the On/Off switch again to stop circulation.

Maintenance

The preferred cleaning method for the vest is to use a damp cloth for stain removal. Machine washing with cold water on a gentle or delicate cycle is also acceptable using a laundry bag. Hang drying is the only acceptable drying method.

Do not use bleach, an iron or place the vest in a machine dryer.

The ice chest and 3.0L container can be cleaned with a mild soap, like dish detergent.

Storage

Ice chest and 3.0L container; Empty all water and wipe dry. If possible, leave lids open during storage.

Vest; Connect the vest to the pump on the ice chest. Press the On/Off switch to restart circulation and the pump will push the water from the cooling channels in the vest to the ice chest. Remove vest and empty the remaining water.

Hang-dry the bladder and vest in a cool, dry place for a minimum of 10 hours before long-term storage.

Battery Storage

- Keep in a clean, dry, and ventilated room at 0°C-35°C (32°F-95°F)
- Keep away from any heat source
- Do not touch corroded contacts or elements
- Charge stored batteries every 6 months
- Keep batteries out of children's reach

 Do not use batteries if any damage or abnormalities are observed

Restarting the system; after long term storage, charge the battery and fill the bladder with clean water. Assemble the system as described under System Operation (page 6) and run the unit for a minimum of 10 minutes to reactive pump.

Optional Components

1. Pumps:
 - On/Off type; 500ml/min water flow. Reference Figure A.
 - Flow Control type; 3 flow selections at 200, 350 or 500ml/min. Reference Figure B.
2. Batteries:
 - 7.4V 2.2A battery. Reference Figure C.
 - 7.4V 5.0A battery. Reference Figure D.
3. Extension tubing:
 - Extension tubing with screw-in fitting and female quick fitting 3ft
 - Extension tubing with screw-in fitting and female quick fitting 6ft



Figure A



Figure B



Figure C



Figure D



Safety:



Warning: It is important to become thoroughly familiar with the operating characteristics of the Ice chest cooler system. It is the owner's responsibility to assure proper User training of the cooling system including component knowledge, system preparation, system operation and maintenance. Disregarding this warning can result in injury to the operator and severe mechanical damage to the unit.

Warranty:

Compcooler warrants this product to be free from defects in workmanship and materials, under normal residential use and conditions, for a period of one (1) year from the date of shipment. Shipping and handling fees are to be paid for by the customer. The manufacturer agrees, at its option during the warranty period, to repair any defect in material or workmanship or to furnish a repaired or refurbished product of equal value in exchange without charge (except for fees for shipping, handling, packing, return postage, and insurance which will be incurred by the customer). Such repair or replacement is subject to verification of the defect or malfunction and proof of purchase as confirmed by showing the model number on original dated sales receipt.

Certifications

