

Waistpack ICE Water Cooling System

Model: COMP-BWCS-7415V

Operation Manual

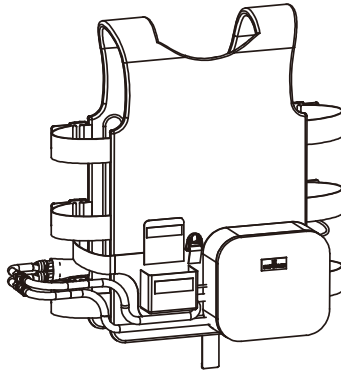

COMPCOOLER

PERSONAL THERMAL TECHNOLOGY

COMPCOOLER

Personal Thermal Technology

Personal Liquid Circulation Cooling System

- Liquid Cooling Garment
- ICE Water Cooling Unit
- Mini Chiller Cooling Unit

Reduce body core temperature and decrease the incidence of thermal stress while increase comfort, safety, focus and endurance.

Contents

System Description.....	1
Components.....	2
Component Description.....	2-3
Performance.....	4
Garment Sizing.....	4
System Preparation.....	5
System Operation.....	5-6
Maintenance.....	6
Storage.....	6-7
Optional Components.....	7
Safety.....	8
Warranty.....	8
Certifications.....	8



System Description:

The Compcooler Waistpack Ice Cooling System combines a tubing-lined vest with a liquid cooling system housed in a detachable waistpack to form a self-contained and convenient thermal regulation device.

The vest is a highly engineered breathable mesh garment that weighs a mere 0.5KG (1.1 lbs.), dry weight. It consists of a soft mesh outer fabric and inner liner which is easy to don and comfortable to wear against the body. A zipper and adjustable tabs provide a snug fit for maximum thermal transfer. The liquid cooling system is a detachable waistpack that weighs 1.5KG (3.3 lbs.), dry weight. It contains a 1.5-liter removable water bladder, circulation pump, rechargeable battery, and On/Off switch. When operating, it's audible output is 45dBa.

Cooling energy is provided by freezing the water in the bladder. This is easily accomplished by removing the bladder from the system using quick-connect fittings, and then placing the bladder in a freezer. Once frozen, the bladder is easily re-attached to the system using the quick-connect fittings. With a charged battery pack, Users turn the switch on and the pump circulates cold water in a continuous loop between the bladder and vest. With the included 1.5-liter bladder, Users can expect a cooling duration anywhere from 1 to 2 hours depending on ambient temperatures and workload. Additional bladders and battery packs can be purchased for prolonged cooling.

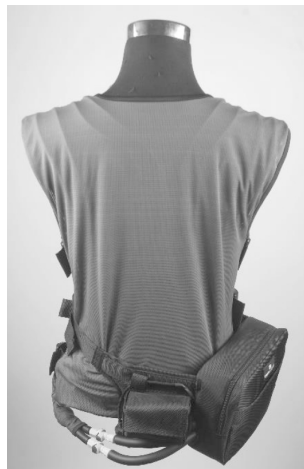

Components List

COMP-BWCS-7415NF (On/Off Operation)

Item	Description	Quantity
1	Liquid cooling vest	1
	Waistpack Circulation System:	
2	• Water pump, simple ON/OFF operation	1
3	• Battery 7.4V 2200mAh	1
4	• 3.0L Bladder	1
5	Battery charger 110-220V	1
6	Manual	1

COMP-BWCS-7415FC (Flow Control Operation)

Item	Description	Quantity
1	Liquid cooling vest	1
	Waistpack Circulation System:	
2	• Water pump, flow control operation	1
3	• Battery 7.4V 2200mAh	1
4	• 3.0L Bladder	1
5	Battery charger 110-220V	1
6	Manual	1

Component Description

Liquid Cooling Vest:

1. Outer Fabric; Soft stretch mesh
2. Liner; Soft stretch mesh
3. Cooling Channel; Silicone micro-tubing
4. Aluminum manifold
5. Male quick-connect fittings
6. Front Zipper
7. Adjustable tabs

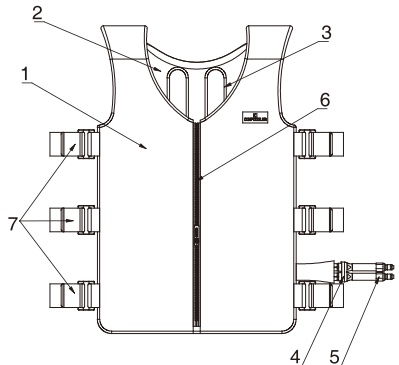

Waistpack Circulation System:

- 8. Waistpack, black oxford outer color
- 9. Waistpack pack flap with reflective insulation liner
- 10. 1.5L Bladder with quick release fittings
- 11. 7.4V pump, 500ml/min
- 12. 7.4V 2200mAh rechargeable Li-Ion battery
- 13. Power Switch: simple On/Off operation
- 14. Female quick-connect fittings
- 15. Waterproof zipper
- 16. Bladder with female quick-connect fittings

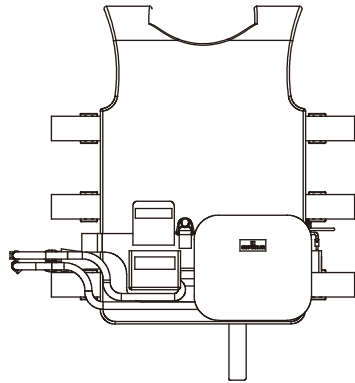
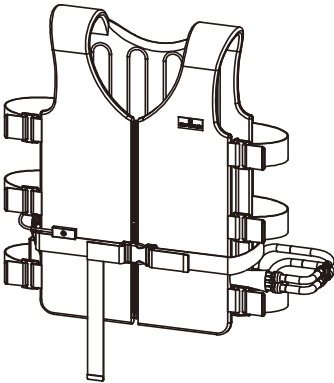
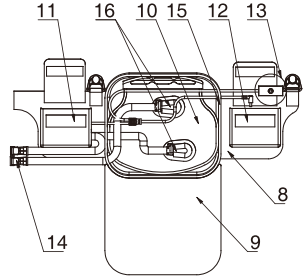

**View of waistpack
donned with vest**

Performance:

Combined Vest and Waistpack

- Cooling time:
 - 1-2 hours with 3.0L frozen bladder
 - **0.5-1** hours with ice cubes
- Circulation: 500ml/min
- Temperature range: 2° - 10°C (36 - 50°F)
- Operation ambient: 0 - 60°C (32 - 140°F)

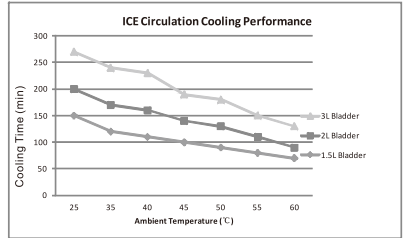

Rechargeable battery, 7.4V 2.2A

- Battery life: 8 hours
- Charging time: 3-5 hours

Rechargeable battery, 7.4V 5A

- Battery life: 20 hours
- Charging time: 4-5 hours

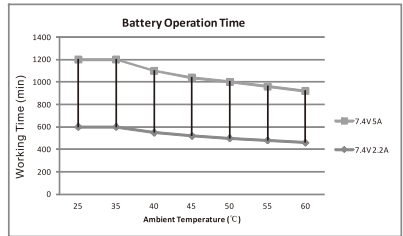

Garment Sizes

Garment can expand 15% (max 15cm/6") with adjustable tabs.

Feature	XS/S	M/L	XL/XXL	3XL/4XL
Chest	84cm/33.1"	100cm/39.4"	108cm/42.5"	126cm/49.6"
Length	64cm/25.2"	68cm/26.8"	70cm/27.6"	73cm/28.8"



System Preparation

1. **Battery:** Charge the battery using the included charging cord. LED lights on the battery housing indicate charging progress. A red light indicates the battery is still charging. A green light indicates the battery is fully charged. Reference Figure C.

Pressing “Remaining Battery Capacity” on the battery indicates, by percentage, how full the battery is. 3 Led lights indicate 80-100% capacity, 2 lights indicate 60-80% capacity and 1 light indicate \leq 50% capacity. Reference illustration at right.

Typical charge time to ‘full’ is 4 hours. A fully charged battery will operate up to 8 hours.



2. **Bladder:**

Unzip the waistpack and remove the bladder from the system by depressing the quick-connect fittings that attach the bladder to the vest.

Remove the plastic roll-top slider at the top of the bladder and fill it with water. Take care not to exceed the fill line. The remaining air pocket in the bladder is required for the system to work properly.

Lay the bladder flat in a freezer and allow the water to completely freeze for optimum performance. Note: Ice cubes can also be used if there is not enough time to wait for a frozen bladder. In this case, add ice cubes to the bladder and top off with water, taking care not to exceed the fill line. While ice cubes will provide adequate performance, the cooling time will be reduced.

Note: if bladder is not laid flat, or if it was over-filled with water, the quick-connect fittings may freeze and not allow circulation. If such an instance occurs, simply pour tepid water on the quick-connect fittings until the water in these fittings is melted.

System Operation

1. **Attach Bladder;** Once frozen, remove the roll-top slider on the bladder and add 100-200ml water. This water serves as the initial coolant that flows through the pump and vest tubing. With the waistpack unzipped, re-assemble the roll top and attach the bladder to the pump in the waistpack using the quick-connect fittings. An audible ‘click’ of the quick-connect fittings ensures a proper connection. Zip the waistpack closed.
2. **Battery connection;** Connect the battery with the pump using the provided plug.

System Operation, Cont'd

3. **System check;** before donning, connect the tubes on the vest to the tubes on the waistpack using the quick-connect fittings. An audible 'click' of the quick-connect fittings ensures a proper connection. Note: orientation of the tubes does not matter. Turn the system 'On' using the On/Off switch. An audible sound of the pump and visual inspection of flowing water near the inlet fitting are initial signs of a properly operating system. At this point check the bladder and quick-connect fittings for leaks. Any leaks must be remedied before donning the system. After performing the system check, disconnect the vest from the waistpack using the quick-connect fittings.
4. **Don the vest;** Once donned, zip the vest and adjust the tabs to create a snug fit. For optimal cooling performance, wear the vest against bare skin.
5. **Don the waistpack;** Secure the waistpack with the provided belt and make adjustments for a comfortable fit. The included shoulder strap can also be used to reduce the weight load.
6. **Connect vest to waistpack;** connect the tubes on the vest to the tubes on the waistpack using the quick-connect fittings. An audible 'click' of the quick-connect fittings ensures a proper connection.
7. **Start cooling;** Press the On/Off switch located on the waist belt to start the cold water circulation. Press the On/Off switch again to stop circulation.



Maintenance

The preferred cleaning method for the vest is to use a damp cloth for stain removal. Machine washing with cold water on a gentle or delicate cycle is also acceptable using a laundry bag. Hang drying is the only acceptable drying method.

Do not use bleach, an iron or place the vest in a machine dryer.

Storage

Waistpack Circulation System; Disconnect the bladder from the waistpack and empty the water.

Vest; Connect the empty bladder to the pump in the waistpack. Position the vest upside down. Press the On/Off switch to restart circulation and the pump will push the water from the cooling channels in the vest to the bladder. Remove bladder again and empty the remaining water.

Hang-dry the bladder and vest in a cool, dry place for a minimum of 10 hours before long-term storage.

Storage, Cont'd

Battery Storage

- Keep in a clean, dry, and ventilated room at 0°C-35°C (32°F-95°F)
- Keep away from any heat source
- Do not touch corroded contacts or elements
- Charge stored batteries every 6 months
- Keep batteries out of children's reach



Do not use batteries if any damage or abnormalities are observed

Restarting the system; after long term storage, charge the battery and fill the bladder with clean water. Assemble the system as described under System Operation (page 6) and run the unit for a minimum of 10 minutes to reactive pump.

Optional Components

1. Pumps:

- On/Off type; 500ml/min water flow. Reference Figure A.
- Flow Control type; 3 flow selections at 200, 350 or 500ml/min. Reference Figure B.



Figure A



Figure B

2. Batteries:

- 7.4V 2.2A battery. Reference Figure C.
- 7.4V 5.0A battery. Reference Figure D.



Figure C



Figure D

Safety:



Warning: It is important to become thoroughly familiar with the operating characteristics of the Waistpack ICE Water Cooling System. It is the owner's responsibility to assure proper User training of the cooling system including component knowledge, system preparation, system operation and maintenance. Disregarding this warning can result in injury to the operator and severe mechanical damage to the unit.

Warranty:

Compcooler warrants this product to be free from defects in workmanship and materials, under normal residential use and conditions, for a period of one (1) year from the date of shipment. Shipping and handling fees are to be paid for by the customer. The manufacturer agrees, at its option during the warranty period, to repair any defect in material or workmanship or to furnish a repaired or refurbished product of equal value in exchange without charge (except for fees for shipping, handling, packing, return postage, and insurance which will be incurred by the customer). Such repair or replacement is subject to verification of the defect or malfunction and proof of purchase as confirmed by showing the model number on original dated sales receipt.

Certifications

Certifications	<p>CE, UL, FDA, FCC, RoHS, PSE</p> <p>     RoHS  </p>
----------------	--

Quality System	  
----------------	--

Customer service:

simonsun@compcooler.com



COMP cooler

Personal Thermal Technology,
Keep you body cool and comfortable in harsh conditions!

On line Shopping



www.compcooler.shop

simonsun@compcooler.com

Designed in USA
Made in China