

05.0513.01Rev. 04

COMPRESSED

AIR ADVISORS ONLINE, INC.

YOUR COMPRESSED AIR PARTNER

www.compressedairadvisors.com



SCHULZ

Schulz of America, Inc.

3420 Novis Pointe

Acworth, GA 30101

Phone # (770) 529 4731 / 32

Fax # (770) 529 4733

sales@schulzamerica.com

www.schulzamerica.com

AIR COMPRESSOR OWNER'S MANUAL

AIR COMPRESSOR OWNER'S MANUAL

TABLE OF CONTENTS

SAFETY GUIDELINES	1
HAZARD SYMBOLS	1
PRECAUTIONS & WARNINGS	1
DESCRIPTION OF OPERATION	2
PRINCIPLES OF COMPRESSION CYCLES	2
APPLICATIONS	2
SYSTEM COMPONENTS	3
INSTALLATION	3
ELECTRICAL DIAGRAM	5
AIR DISTRIBUTION NETWORK TYPICAL INSTALLATION DIAGRAM	11
START-UP CHECKLIST	12
BREAK-IN PROCEDURES	12
MAINTENANCE SCHEDULE	13
SERVICE PROCEDURES	14
TROUBLESHOOTING	17
LIMITED WARRANTY	18
TECHNICAL DATA 360VL15X	19
AIR COMPRESSOR PARTS	19
BARE PUMP PARTS	20
TECHNICAL DATA 580VL20X	21
AIR COMPRESSOR PARTS	21
BARE PUMP PARTS	22
TECHNICAL DATA 580VL20X- NS	23
AIR COMPRESSOR PARTS	23
BARE PUMP PARTS	24
TECHNICAL DATA 580VV20X	25
AIR COMPRESSOR PARTS	25
BARE PUMP PARTS	26
TECHNICAL DATA 580HV20X	27
AIR COMPRESSOR PARTS	27
BARE PUMP PARTS	28
TECHNICAL DATA 7.580VL30X	29
AIR COMPRESSOR PARTS	29
BARE PUMP PARTS	30
TECHNICAL DATA 7.580VV30X	31
AIR COMPRESSOR PARTS	31
BARE PUMP PARTS	32
TECHNICAL DATA 7.580HV30X	33
AIR COMPRESSOR PARTS	33
BARE PUMP PARTS	34
TECHNICAL DATA 10120HL40X	35
AIR COMPRESSOR PARTS	36
BARE PUMP PARTS	37
TECHNICAL DATA 10120HW40X	38
AIR COMPRESSOR PARTS	39
BARE PUMP PARTS	40
TECHNICAL DATA 15120HW60X	41
AIR COMPRESSOR PARTS	42
BARE PUMP PARTS	43
TECHNICAL DATA 20120HWV80X	44
AIR COMPRESSOR PARTS	45
BARE PUMP PARTS	46
ENVIRONMENTAL GUIDANCE AND RECOMMENDATIONS	47

SAFETY GUIDELINES

HAZARD SYMBOLS

Throughout this manual we have identified key safety hazards. The following symbols identify the level of hazard seriousness.

 **DANGER** Immediate hazard which will result in severe personal injury or death.

 **WARNING** Hazards or unsafe practices that could result in severe personal injury or death.

 **CAUTION** Hazards or unsafe practices that could result in minor personal injury or product or property damage.

PRECAUTIONS & WARNINGS

Air compressors are high-speed mechanical equipment requiring caution in operation to minimize harm to property and personnel. There are many obvious safety rules that must be observed in the operation of this type of equipment. Therefore not all safety precautions that must be observed with compressors and compressed air systems are listed here. Failure to follow any of these warnings may result in severe personal injury, death, property damage and/or compressor damage.

- Air from this compressor will cause severe injury or death if used for breathing or food processing. Air used for these processes must meet O.S.H.A. 29 C.F.R. 1910.134 or F.D.A 178.3570 regulations.
- This compressor is designed for use in the compression of normal atmospheric air only. No other gases, vapors or fumes should be exposed to the compressor intake, nor processed through the compressor.
- Turn off and lockout/tagout (per O.S.H.A. regulation 1910.147) the main power switch, then release all pressure from the system, before attempting to service or perform maintenance procedures.
- Relieve all pressure internal to the compressor prior to servicing per O.S.H.A. regulation 1910.147. Do not depend on check valves to hold system pressure.
- A properly sized safety relief valve must be installed in the discharge piping before (downstream) any shut-off valve, heat exchanger, orifice or any potential blockage point. Failure to install a safety relief valve could result in rupturing or explosion of some compressor or safety component.
- Do not operate the compressor over the A.S.M.E. pressure vessel rating for the receiver or the service rating of the compressor, whichever is lower.
- Do not change the pressure setting of the safety relief valve, restrict function of the safety relief valve or replace the safety relief valve with a plug. Over pressurization of some system or compressor component can occur, resulting in severe personal injury, death and property damage.
- Do not operate the unit with any of its safety guards, shields, or screens removed.
- Do not attempt to service any part of the unit while the compressor is operating.
- Never use plastic pipe or rubber hose not specifically rated for the necessary pressure and temperature, or lead-in soldered joints in any part of the compressed air system.
- Do not remove or paint over any DANGER!, WARNING!, CAUTION! or instructional materials attached to the compressor. Lack of information regarding hazardous conditions can cause property damage or personal injury, or death.

SAFETY GUIDELINES

- Provisions should be made to have the owners manual readily available to the operator and maintenance personnel. If for any reason any part of the manual becomes illegible or the manual is lost, have it replaced immediately. The owners manual should be read periodically to refresh one's memory. It may prevent a serious or fatal accident.
- Never use a flammable or toxic solvent for cleaning the air filter or any parts.
- Make a general overall inspection of the unit daily and correct any unsafe conditions.
- Never play with compressed air. Reckless behavior of any kind involving compressed air can cause serious personal injury.
- Periodically check all pressure relief valves for proper operation.
- Any alterations to the compressor must have prior factory approval.

DESCRIPTION OF OPERATION

PRINCIPLES OF COMPRESSION CYCLES

A reciprocating compressor is a piston type pump that develops pressure from the action of a piston moving through a cylinder. The cylinder, or cylinders, may be vertical, horizontal, or angular.

SINGLE STAGE - When air is drawn in from the atmosphere and compressed to its final pressure in a single stroke, the compressor is referred to as a "single stage" pump. During the downstroke of a single stage compressor, air is drawn through an intake valve in the head of the compressor and into the cylinder. At the bottom of the stroke, the intake valve closes and air is trapped in the cylinder. The air is then compressed in the cylinder during the upstroke of the piston.

TWO STAGE - Compressing air to higher pressure it is accomplished by using multiple stages. During the downstroke of the piston of a "**two stage**" pump, air is drawn through an intake valve in the head of the compressor, into the low-pressure cylinder and compressed during the upstroke of the piston. The compressed air is then released through a discharge valve in the head of the compressor to an intercooler where the heat resulting from compression is allowed to dissipate. The cooler compressed air is then drawn into a second compression cylinder, the high pressure cylinder, for compression to final pressure. From here the compressed air is released through a discharge valve to an air receiver tank. In one revolution of the crankshaft a compression cycle is completed.

APPLICATIONS

Single stage compressors normally runs in the 95 up to 125 psi range. These pressure settings are designed to provide working air in the 90 up to 100 psi range that most air tools operate. These compressors are generally used in lighter duty applications such as in your garage at home.

A two-stage compressor normally run in the 145 up to 175 psi range. The higher-pressure setting of the two-stage unit is required in commercial and industrial applications that have tools and equipment such as in-ground lifts and tire changers that need air at higher pressure than a single stage compressor can provide. Two stage compressors are generally better suited for commercial use for several other important reasons. First, this high-pressure air is store in the tank as "available energy" so the compressor runs less. Secondly, two stage compressors run at much lower discharge temperatures so that you have cooler, dryer air in the shop air system. The two-stage compressor is more versatile because it gives the shop owner the ability to use the higher pressures when necessary but also use air regulated down of the 90 up to 100 psi range for normal air tools.

ENVIRONMENTAL GUIDANCE AND RECOMMENDATIONS

1. Disposal of Liquid Effluents

The presence of liquid effluents or non-treated condensation from tank and separator in rivers, lakes or in other water receiving bodies may adversely affect the aquatic life and the water quality as well.

The condensation withdrawn from the tank and separator, daily, according to the Preventive Maintenance Chapter, must be kept in a container and/or in an appropriate collecting network for further treatment.

Schulz, the manufacturer of the product, recommends that the liquid effluent produced inside the receiver of the compressor or condensed separator should be adequately treated through processes that aim at protecting the environment and the healthy quality of life of the population, complying with the country's current regulation requirements.

Among the treatment methods available, one may choose the physical-chemical, chemical, and biological ones. The treatment may be carried out by the company itself or by outsourcing.

2. Draining the Lubricant Oil from the Compressor Unit

The disposal of the lubricant oil coming from the lubricant oil change located in the crankcase of the piston compressor must meet technical requirements, as well as the regulation requirements of the current legislation of the country the product has been exported to.

3. Disposal of Solid Waste (parts in general and product packages)

The generation of solid waste is an important aspect that must be considered by the users when using and maintaining their piece of equipment. The impacts to the environment may cause meaningful changes in the quality of the soil, in surface and underground water, and in the population's health, due to the inadequate disposal of the discarded residues (on streets, water springs, landfills, etc).

Schulz, the manufacturer of the product, recommends that the waste arising from the product, from its generation, handling, transportation, and treatment to its final disposal should be handled carefully. Appropriate handling should consider the following steps: quantification, qualification, classification, reduction at source, pick-ups and selective pick-ups, recycling, storage, transport, treatment and final destination.

The disposal of solid waste must be carried out according to the regulation requirements of the current legislation of the country the product has been exported to.

TECHNICAL DATA 20120HWV80X

BARE PUMP PARTS

Position	ft.lb	lb.in	N.m
(T1) 49	25	304	34
(T2) 8	58	704	80
(T3) 2	5.8	70	8
(T4) 28	13	158	18
(T5) 12	101	1,215	137
(T6) 14	27.8	334	38
(T7) 23	15	185	21
(T8) 61	12	141	16
(T9) HP-LP 40-41-59	1.6	19	2.2
(T10) LP 40-41-59	3.6	44	5
(T11) 58	22	264	30

TABLE 1 TORQUE SPECIFICATION FOR BOLTS

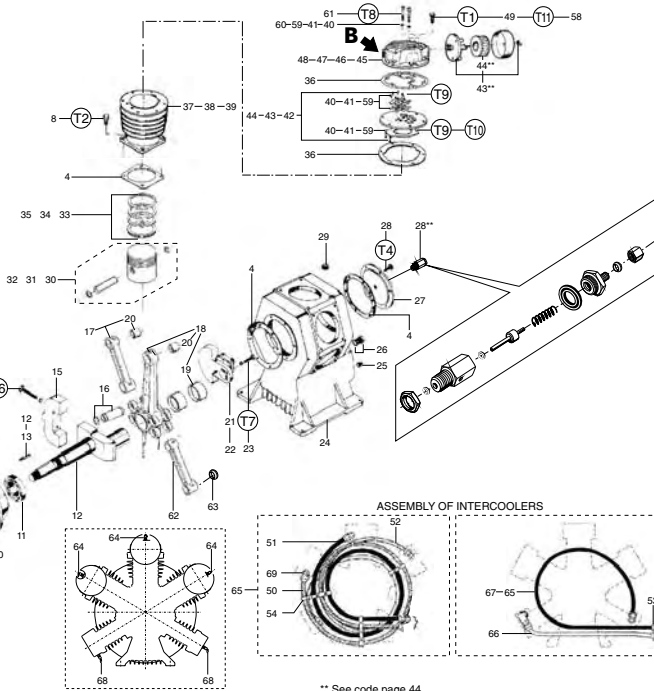
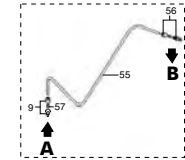

No.	CODE	DENOMINATION	QTY	No.	CODE	DENOMINATION	QTY
1	709 1346 0	Flywheel	01	36	830 1031 0/NA	Upper gasket kt	01
2	20505001	UNC 1/4" x 3/4" head bolt	04	37	709 1306 0	LP 4 3/4" cylinder	03
3	830 1033 0/NA	Flange cover	01	38	709 1308 0	HP 90mm cylinder	01
4	60082501	Crankcase gasket kit	01	39	709 1347 0	HP 2 1/2" cylinder	01
5	830 0932 0	Oil seal	01	40	830 0955 0	LP 4 3/4" valve plate kit	03
6	60154501	Lock washer and nut kit	01	41	830 1002 0	HP 90 mm valve plate kit	01
7	60154502	33109 bearing	01	42	809 1028 0	LP 4 3/4" valve plate	03
8	60259501	NC 1/2" x 1" head bolt	26	43	809 1027 0	HP 90mm valve plate	01
9	20504001	Straight fitting	01	44	809 1029 0	HP 2 1/2" valve plate	01
10	60154501	Flange	01	45	709 1272 0	LP 4 3/4" cylinder cover (with breather)	01
11	60154501	32211 bearing	01	46	709 1423 0	LP 4 3/4" cylinder cover (without breather)	02
12	830 0933 0	Crankshaft kit	01	47	709 1424 0	HP 90mm cylinder cover	10
13	60267503	Key	01	48	709 1389 0	HP 2 1/2" cylinder cover	01
14	20508005	UNF 3/8" x 3" head bolt	02	49	709 1457 0	UNC 3/8" x 1 1/2" head bo t	23
15	830 0934 0	Connecting rod pin kit	01	50	21011004	Short intercooler No 2	01
16	30088502	Connecting rod	04	51	709 1459 0	Medium intercooler No 3	01
17	830 0938 0	Connecting rod	03	52	709 1458 0	Long intercooler No 4	01
18	830 0938 0	Master connecting rod	01	53	21011004	3/4" nut for intercooler	01
19	60152502	Connecting rod inner bushing	02	54	21029003	Intercooler holder	03
20	60152501	Connecting rod bushing	07	55	830 0340 5	1/4" crankcase breather tube	01
21	30007007	Counter weight with centrifugal mechanism	01	56	003 0054 0	1/8" x 1/4" straight connection	01
22	830 0937 0	Counter weight kit with centrifugal mechanism	01	57	830 0599 8	1/4" ring kt	01
23	20501001	UNF 5/16" x 1 1/4" Allen head bolt	02	58	383 0111 0	HP 5/16" x 1 1/2" Allen hex bolt	06
24	003 0029 2	3/8" plug	01	59	830 0957 0	HP 2 1/2" valve plate kit	01
25	830 0775 0	3/4" o 1 level sight kit	01	60	830 1032 0	Washer kit	01
26	709 1316 0	Crankcase cover	01	61	013 0752 0	M6 x 1 x 55 Allen hex bolt	08
27	003 0031 4	3/4" plug	06	62	830 1202 0	Connecting rod with needle bearing	01
28	60273501	LP 4 3/4" piston	01	63	019 0079 0	Needle bearing	02
29	830 1000 0	HP 90mm piston kit	01	64	022 0177 0	LP 1/8" ASME safety valve	03
30	830 0939 0	HP 2 1/2" piston kit	01	65	809 1043 0	Intercooler kit without tube No 1 (item 66)	01
31	000 0077 0	LP 4 3/4" ring kit	01	66	709 1369 0	Discharge tube No 1	01
32	000 0080 0	HP 90mm ring kit	01	67	709 1456 0	Discharge tube No 5	01
33	000 0075 0	HP 2 1/2" ring kit	01	68	022 0215 0	HP 1/8" ASME safety valve	02
34	000 0080 0	HP 90mm ring kit	01	69	21011002	3/4" x 3/4" straight connection	06
35	000 0075 0	HP 2 1/2" ring kit	01				

* Part available in the market - not sold by Schulz
Note: HP high pressure LP low pressure

DESCRIPTION OF OPERATION

SYSTEM COMPONENTS

Pressure Switch - The pressure switch senses the air pressure in the system and automatically starts the motor when the pressure drops below the cut in setting. Once the pump builds the pressure up to the maximum or cut out pressure, the pressure switch shuts off the motor and bleeds down the air pressure between the pump and check valve. This allows the motor to restart in an unloaded mode.

Check Valve - The check valve is a device that allows the air to flow in only one direction. While the compressor is running, the check valve is "open", allowing the air to flow from the pump to the tank. When the compressor stops, the check valve is "closed" and keeps the air in the tank from trying to back up to the pump.

Pressure Relief Valve - This valve is often called a "pop-off" or a "safety relief valve". Its job is to open up and relieve the air pressure in the event the pump did not shut off at the maximum setting.

Tank Drain Valve - This valve, also known as a petcock, is to drain out any condensation in the tank. Since some moisture will form inside the tank every time the compressor runs, it is important to drain the tank daily.

Intake Air Filter - As air is drawn into the compressor pump it must pass through a filter to remove dirt and dust. When the filter element becomes clogged with dirt it creates a high vacuum condition in the cylinder which can cause the oil from the crankcase to be sucked up past the rings and into the tank.

ON/OFF Switch - Starts and stops the air compressor. It is important to remember that in the "On" position, the compressor can start automatically. The compressor should not be turned off in mid-cycle using the switch (except in an emergency) so that the pressure switch is allowed to relieve the head pressure when it turns off the compressor.

Pressure Gauge - The pressure gauge reads the air pressure in the tank or air system.

SHUT OFF Valve - A ball or gate valve that is installed on the tank where the air is going out to the shop air system. This valve is used during scheduled maintenance to separate the compressor from the rest of the air system. It could also be important to quickly shut off the air from the tank in case of a problem like an airline breaking.

Cooling System - Air compressor pumps create remarkable amount of heat as they operate. Because so much heat is generated, the cooling system of the compressor is critical to the life of the pump. Compressor pumps are heavily finned to dissipate heat. Cooling air is blown over the fins by the fan blades designed into the flywheel of the pump. The inter cooler and after cooler lower the air temperature significantly, thereby making it easier to compress the air.

INSTALLATION

Location - The air compressor should be installed in a clean, dry, well lighted, and well ventilated area on a level floor. The flywheel side of the compressor should be towards the wall and the distance between the compressor and the wall should be a minimum of 30" to allow for proper cooling air circulation, inspections, and maintenance.

WARNING Under no circumstances should a compressor be placed in an area that may be exposed to a toxic, volatile or corrosive atmosphere nor should toxic, volatile or corrosive agents be stored near the compressor.

Mounting - Your compressor must be installed according to all applicable State and Local Laws. Shims may be needed to level the legs. Care must be taken when tightening anchor bolts. Uneven torque can lead to excessive vibration that can weaken welds and cause explosions. Tighten three leveled legs equally and leave the fourth nut loose.

INSTALLATION

Air Intake - Do not locate the compressor where it could ingest toxic, volatile or corrosive vapors or extremely dirty air. If a remote inlet filter is going to be installed you must increase one pipe size for every ten feet in length and use a flex hose between the pump and any solid pipe to minimize the potential of damage from vibration.

Piping - The main distribution line should not be any smaller than the pipe size of the shut off valve of the compressor. It is recommended that the shop air system be connected to the air compressor shut off valve with a flexible coupler to reduce the risk of damage from vibration. All airlines should slope to an accessible drain or moisture trap for removal of condensation. Make sure that there are no leaks in the airlines as even small leaks can cause your compressor to run outside of the rated duty cycle. A typical installation is shown on page 11, note that the feeder lines come off of the top of the main distribution line so that moisture can't enter the feeder line.

WARNING ASME coded pressure vessels must not be modified, welded, repaired, reworked or subjected to operating conditions outside the nameplate ratings. Such actions will negate code status, affect insurance status and may cause severe personal injury, death and property damage.

DANGER High voltage may cause personal injury or death. Disconnect and lockout/tagout per O.S.H.A. Regulation 1910.147 all electrical power supplies before opening the electrical enclosure or servicing.

Wiring - Before starting the installation procedure, check that the building's electrical service has an adequate capacity to handle the motor and the same electrical characteristics (voltage, cycle, and phase). Install the compressor as close to the main power supply as possible and follow all National Electric Safety Codes as well as those dictated by State and Local authorities. A qualified electrician must do the electrical installation. Every compressor model has a specific power requirement and the wire size used is critical to a proper installation. The two tables (shown below) are for reference only and should not supersede specific National, State or Local code requirements. The compressor can be manufactured without a *power switch*, according to the product version. **The pressure switch must not be directly connected to the motor but to a control circuit. See "Electrical Diagram" page 5 and 6 to correct installation, according to the product version.**

30 amp circuit		40 amp circuit		60 amp circuit	
0-30 ft.	10 ga	0-25 ft.	8 ga	0-10 ft.	8 ga
31-50 ft.	8 ga	26-50 ft.	6 ga	11-30 ft.	6 ga
51-70 ft.	6 ga	51-75 ft.	4 ga	31-50 ft.	4 ga
71 ft and up: call factory		76 ft and up: call factory		51 ft and up: call factory	

Motor power [hp]		Input supply voltage [V]	Max.fuse (g/LgG)* [A]
single phase	three phase		
3	-	230	50
5	-	230	35
-	5	460	20
7.5	-	230	80
-	7.5	230	50
-	7.5	460	25
-	10	230	63
-	10	460	35
-	15	230	100
-	15	460	50
-	20	230	100
-	20	460	63

Orientalite table for fuses
* type 2 coordination

Orientalite table for wiring

Grounding instructions: This product must be grounded to reduce the risk of an electric shock. Connect the Grounding cable to the motor's terminal, or if there is no terminal to the motor's frame.

WARNING The incorrect installation of the grounding wire connector may result in an electric shock. If it is necessary to replace or repair both the cable and the connector, do not connect or join the grounding wire to the neutral wire or other. The green wire, with or without yellow stripes, is only to the grounding function. In case of doubts regarding the grounding information or whether the product is properly grounded, make sure you contact a qualified electrician to verify the connections.

TECHNICAL DATA 20120HWV80X

AIR COMPRESSOR PARTS

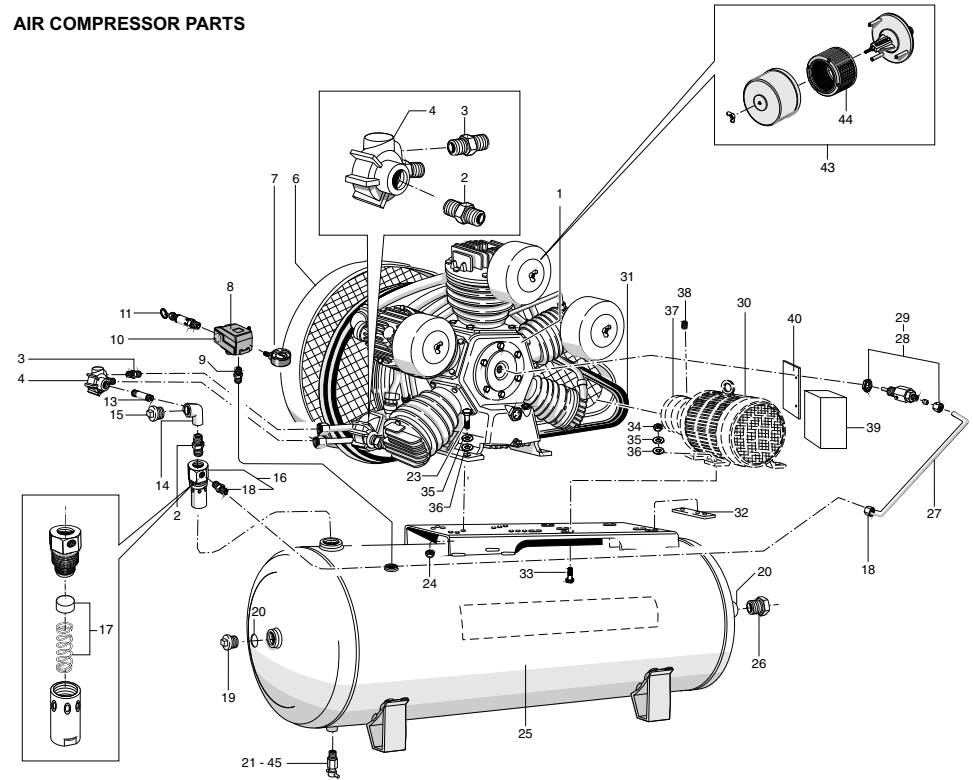

No.	CODE	DENOMINATION	QTY
1	933.9385-0	Bare pump	01
2	003.0036-5	3/4 nipple	02
3	21011001	NPT 3/4 x 1/2 straight connection	04
4	20517005	Upper tubing adaptor	02
6	830.1023-0	Belt guard	01
7	011.0118-0	Pressure gauge	01
8	012.0845-0	Pressure switch	01
9	003.0174-4	1/4 nipple	01
10	012.0723-0	Strain relief	01
11	022.0057-0	1/4 ASME safety valve	01
13	21011006	3/4 x 126mm nipple	01
14	003.0343-0	3/4 side elbow	01
15	003.0031-4	3/4 plug	01
16	60281501	Check valve	01
17	34004508	Check valve kit	01
18	003.0054-3	NPT 1/8 x 1/4 straight connection	01
19	003.0514-0	2 Plug	01
20	023.0339-0	O - ring	02
21	022.0185-0	1/4 tank drain valve	01
23	*	W 1/2 x 1.1/2 hex head bolt	04
24	*	BSW 1/2 hex nut	04
25	25003832A	120 gal. horiz. Tank	01

No.	CODE	DENOMINATION	QTY
26	003.0512-0	2 x 1 reduction bushing	01
27	709.1671-0	1/4 tube	01
28	022.0174-0	Centrifugal unloading valve	01
29	830.1043-0	Centrifugal unloading valve kit	01
30	015.0604-0	Motor 208/230/460V (three-phase)	01
31	004.0022-0	Belt	02
32	21028539	Motor fastening plate	02
33	*	7/16 x 1.3/4 hex head bolt	04
34	*	7/16 hex nut	04
35	*	1/2 lock washer	08
36	*	1/2 washer	08
37	709.1349-0	Pulley	01
38	*	3/8 x 1/2 Allen hex without head	01
39	012.0941-0	Start switch**	01
40	701.0381-0	Support start switch**	01
41	012.0907-0	Start switch pressure switch cord (not shown)**	01
42	012.0910-0	Motor start switch cord (not shown)**	01
43	809.1085-0	3/4 NPT air filter	03
44	007.0118-0	Filter element	03
45	709.1246-0	Hose for tank drain (not shown)	01

* Part available in the market - not sold by Schulz.
** Optional start switch

TECHNICAL DATA 20120HWV80X

MODEL	DISPLACEMENT		MAX PRESSURE		TANK		rpm	Ø PULLEY		BELT SIZE	ELECTRIC MOTOR		DISCHARGE SIZE	O L CAP		WEIGHT WITH MOTOR		COLOR REF	
	cfm	l/min	psig	bar	Geom	Vo lume		2P	inches		mm	hp		kW	VOLTAGE (V)	mi	in qt		lbs
20120HWV80X	80	2,264	175	12	427	113	910	5.7	145	2-B	20	15	Three phase 208/230/460	1"	4,500	4,620	1,370	620	Black (pump) Gray (tank)

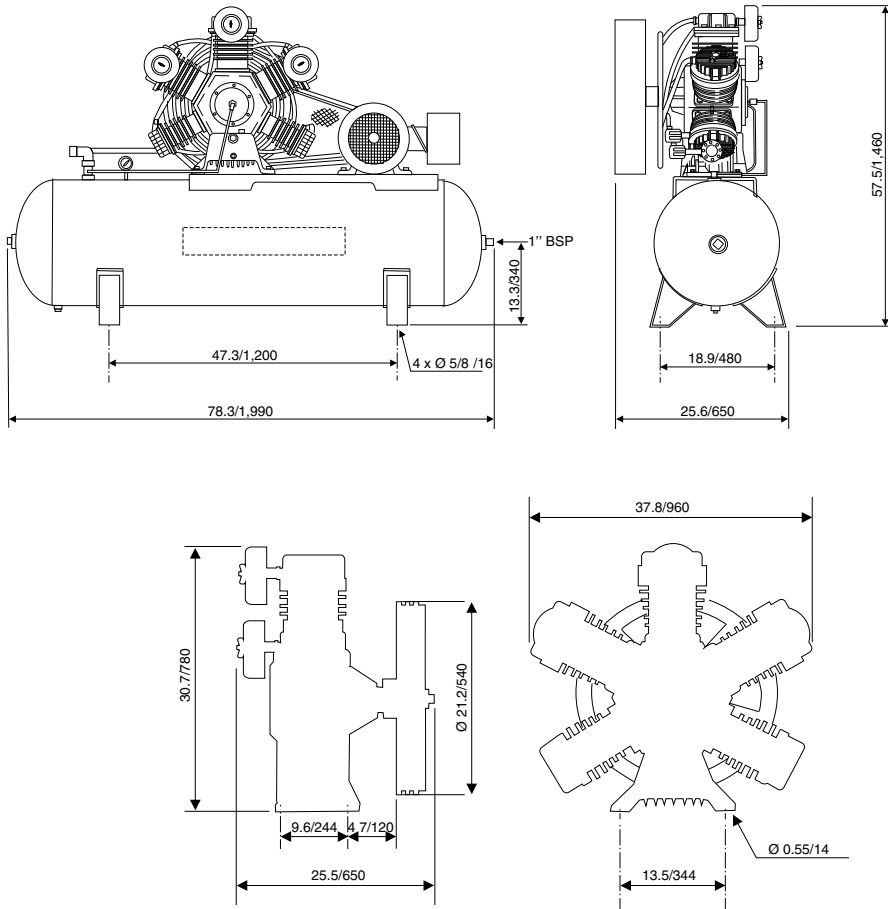

Note: dimensions in inch/mm.

INSTALLATION

ELECTRICAL DIAGRAM

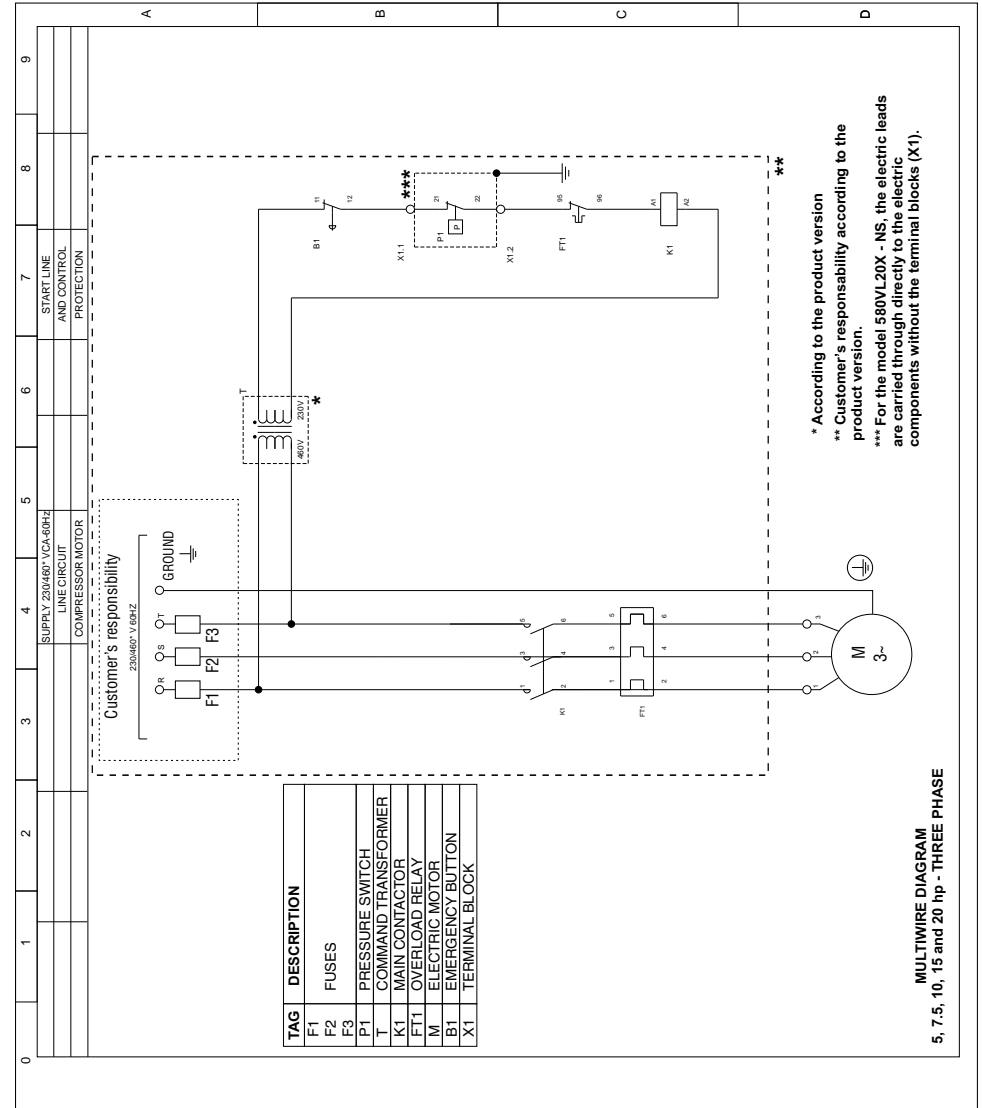

TECHNICAL DATA 15120HW60X

AIR COMPRESSOR PARTS

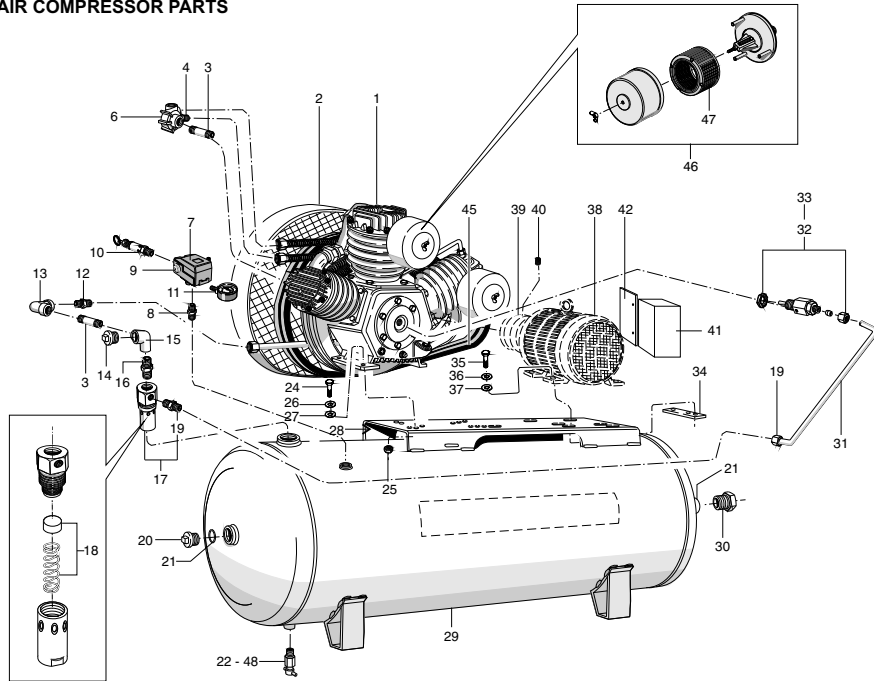

No.	CODE	DENOMINATION	QTY	No.	CODE	DENOMINATION	QTY
1	933.9383-0	Bare pump	01	26	*	1/2 lock washer	04
2	830.1010-0	Belt guard	01	27	*	1/2 washer	04
3	21011009	3/4 x 100mm nipple	02	28	701.0365-0	Support base tank	02
4	21011001	NPT 3/4 x 1/2 straight connection	02	29	25003832A	120 gal hor. tank	01
5	20517005	Upper tubing adaptor	01	30	003.0512-0	2 x 1 reduction bushing	01
6	012.0845-0	Pressure switch	01	31	709.1670-0	1/4 tube	01
7	012.0845-0	Pressure switch	01	32	022.0174-0	Centrifugal unloading valve	01
8	003.0174-4	1/4 nipple	01	33	830.1043-0	Centrifugal unloading valve kit	01
9	012.0723-0	Strain relief	01	34	21028503	Motor fastening plate	02
10	022.0057-0	1/4 ASME safety valve	01	35	*	3/8 x 1.1/2 hex head bolt	04
11	011.0118-0	Pressure gauge	01	36	*	3/8 lock washer	04
12	003.0051-9	NPT 3/4 x 3/4 straight connection	02	37	*	3/8 washer	04
13	60255506	BSP 90° 3/4 elbow	01	38	015.0603-0	Motor 208/230/460V (three-phase)	01
14	003.0031-4	3/4 plug	01	39	709.1325-0	Pulley	01
15	003.0343-0	3/4 side elbow	01	40	*	3/8 x 1/2 Allen hex without head	01
16	003.0036-5	3/4 nipple	01	41	012.0939-0	Start switch**	01
17	60281501	Check valve	01	42	701.0380-0	Support start switch**	01
18	34004509	Check valve kit	01	43	012.0907-0	Start switch pressure switch cord (not shown)**	01
19	003.0054-3	NPT 1/8 x 1/4 straight connection	01	44	012.0909-0	Motor start switch cord (not shown)**	01
20	003.0514-0	2 Plug	01	45	004.0013-0	Belt	02
21	023.0339-0	O ring	02	46	809.1085-0	3/4 NPT air filter	02
22	022.0206-0	1/4 tank drain valve	01	47	007.0118-0	Filter element	02
24	*	W 1/2 x 1.3/4 hex head bolt	04	48	709.1246-0	Hose for tank drain (not shown)	01
25	*	BSW 1/2 hex nut	04				

* Part available in the market - not sold by Schutz.
** Optional start switch

INSTALLATION

LAYOUT

DIRECT ON LINE STARTERS (D.O.L.)

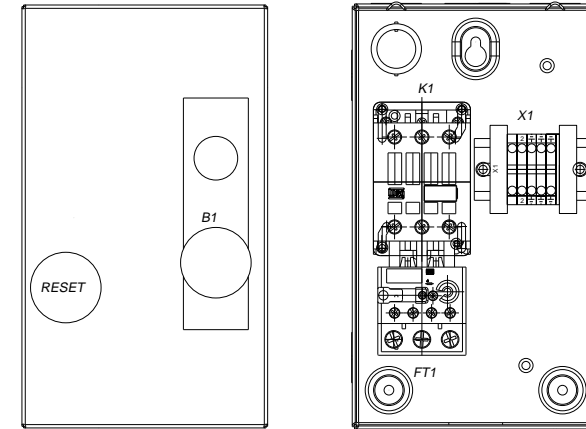

PARTS LAYOUT
5, 7.5, 10, 15 and 20 hp

TAG	DESCRIPTION
K1	MAIN CONTACTOR
FT1	OVERLOAD RELAY
B1	EMERGENCY BUTTON
X1	TERMINAL BLOCKS

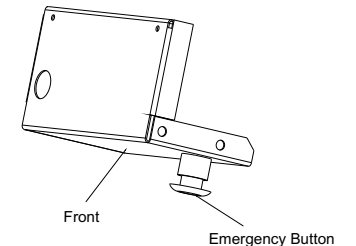
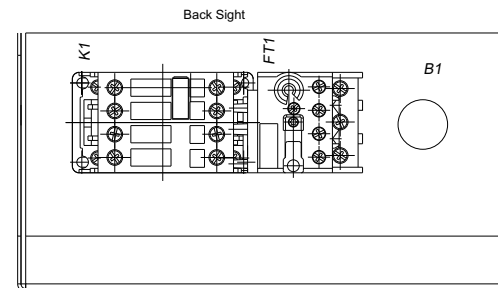

PARTS LAYOUT
5 hp - OPENED D.O.L. STARTER

INSTALLATION

WIRING PROCEDURE
D.O.L. STARTER

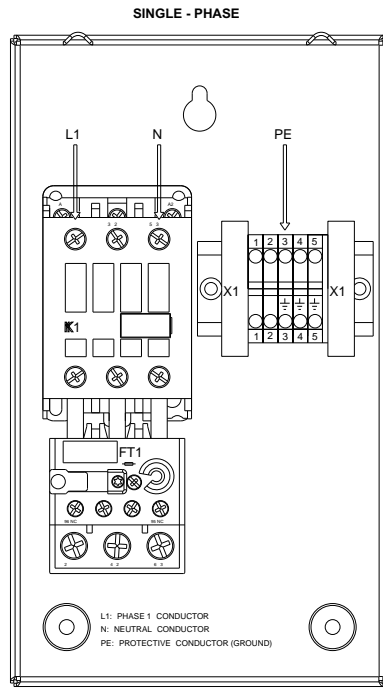

CUSTOMER WIRES LEADS:

MAKE LEADS "L1", "N" AND "PE" TO "1 L1", "5 L3" AND "X1 3" RESPECTIVELY, KEEPING THE OTHERS CONDUCTORS;

MANUFACTORY WIRES LEADS:

- "96 NC" CONNECTED TO "A1"
- "5 L3" CONNECTED TO "A2"
- "1 L1" CONNECTED TO "RED BUTTON"
- "RED BUTTON" CONNECTED TO "X1 2"
- "X1 2" CONNECTED TO "PRESSURE SWITCH"
- "PRESSURE SWITCH" CONNECTED TO "X1 1"
- "X1 1" CONNECTED TO "95 NC"
- "2 T1" CONNECTED TO "3 L2"
- "X1 4" AND "X1 5" CONNECTED TO "PRESSURE SWITCH" AND "MOTOR"
- "4 T2" AND "6 T3" CONNECTED TO "MOTOR"

WARNING:

TURN OFF POWER AND DISCONNECT ALL SUPPLY SOURCE BEFORE SERVICING

TECHNICAL DATA 15120HW60X

MODEL	DISPLACEMENT		MAX PRESSURE		TANK		Q1'	Ø PULLEY		BELT SIZE	ELECTRIC MOTOR		D CHARGE SIZE	OIL CAP		WEIGHT WITH MOTOR		COLOR REF
	cfm	l m n	psig	bar	Geom	Volume		rpm	inches		mm	hp		kw	VOLTAGE [V]	ml	in qt	
15120HW60X	60	1,700	175	12	427	113	1,065	5.9	150	2-B	15	11.3	1"	1,500	1,580	975	442	Black (pump) Gray (tank)

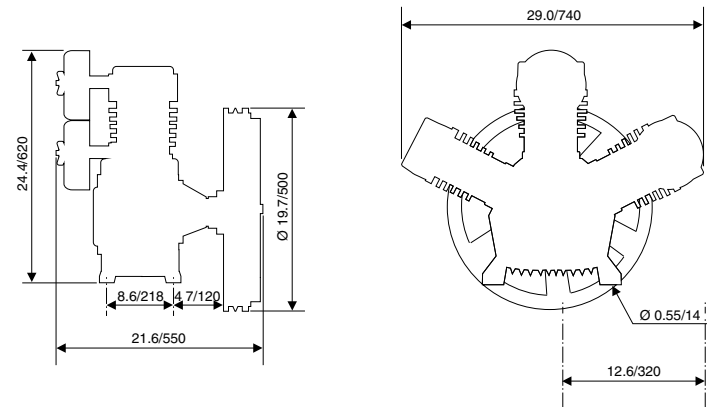
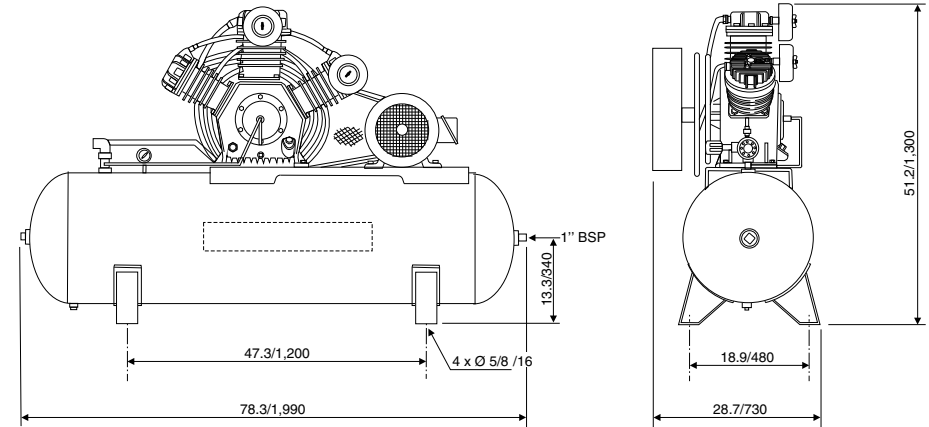

Note: dimensions in inch/mm.

TECHNICAL DATA 10120HW40X

BARE PUMP PARTS

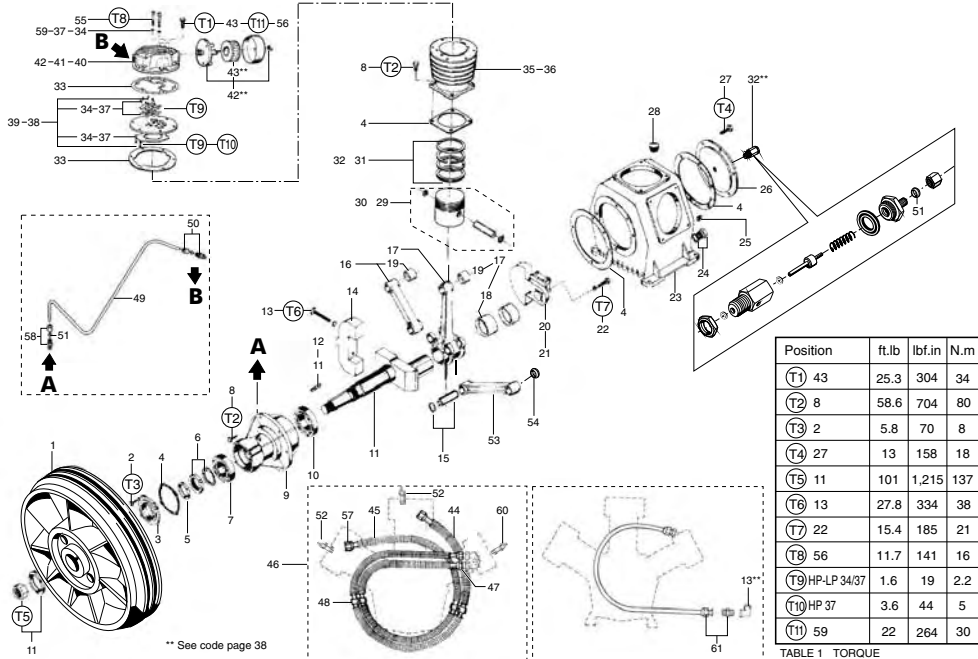

Position	ft.lb	lbf.in	N.m
T1	43	25.3	304
T2	8	58.6	704
T3	2	5.8	70
T4	27	13	158
T5	11	101	1,215
T6	13	27.8	334
T7	22	15.4	185
T8	56	11.7	141
T9	HP-LP 34/37	1.6	19
T10	HP 37	3.6	44
T11	59	22	264

TABLE 1 TORQUE SPECIFICATION FOR BOLTS

No.	CODE	DENOMINATION	QTY	No.	CODE	DENOMINATION	QTY
1	709 1307 0	Flywheel	01	32	000 0077 0	HP 4 3/4" ring kit	02
2	20505001	UNC 1/4" x 3/4" head bolt	04	33	830 1001 0NA	Upper gasket kit	01
3	830 1033 0NA	Flange cover	01	34	830 1002 0	HP 90 mm valve plate kit	01
4	60082501	Crankcase gasket kit	01	35	709 1306 0	LP 4 3/4" cylinder	02
5	830 0932 0	Oil seal	01	36	709 1308 0	HP 90 mm cylinder	01
6	830 0932 0	Lock washer and nut kit	01	37	830 0955 0	LP 4 3/4" valve plate kit	02
7	60154502	33109 bearing	01	38	809 1028 0	LP 4 3/4" valve plate	02
8	60267503	NC 1/2" x 1" head bolt	18	39	809 1027 0	HP 90 mm valve plate	01
9	20504001	Flange	01	40	709 1272 0	LP 4 3/4" cylinder cover with breather	01
10	60154501	32211 bearing	01	41	709 1423 0	LP 4 3/4" cylinder cover	01
11	830 0933 0	Crankshaft kit	01	42	709 1424 0	HP 90 mm cylinder cover	01
12	60267503	Key	01	43	LP UNC 3/8" x 1 1/2" head bolt	12	
13	20508005	UNF 3/8" x 3" head bolt	02	44	709 1322 0/C	No 1 short intercooler	01
14	830 0934 0	Crankshaft counter weight	01	45	709 1322 0/L	No 2 long intercooler	01
15	30008502	Auxiliary connecting rod pin kit	02	46	21011004	Intercooler kit	04
16	830 0930 0	Connecting rod	01	47	21029003	3/4" nut for intercooler	02
17	830 0930 0	Master connecting rod	01	48	830 0340 5	Intercooler holder	02
18	60152502	Connecting rod inner bushing	01	49	003 0054 3	1/4" crankcase breather tube	01
19	30007001	Connecting rod bushing	03	50	NPT 1/8" x 1/4" straight connection	Needle bearing	02
20	830 0937 0	Counter weight with centrifugal mechanism	01	51	830 0599 8	1/4" ring kit	01
21	830 0937 0	Counter weight kit with centrifugal mechanism	01	52	022 0177 0	1/8" LP ASME safety valve	02
22	20501002	UNF 5/16" x 1 1/4" Allen head bolt	02	53	830 1202 0	Connecting rod with needle bearing	01
23	830 0775 0	3/4" oil level sight kit	01	54	019 0079 0	Needle bearing	02
24	003 0029 2	3/8" plug	01	55	013 0752 0	M6 x 1 x 55 Allen hex bolt	05
25	709 1316 0	Crankcase cover	01	56	383 0111 0	HP 5/16" x 1 1/2" Allen hex bolt	06
26	003 0029 2	3/8" plug	01	57	003 0111 6	BSP 90° 3/4" elbow	02
27	60273501	LP 4 3/4" piston	02	58	60255501	Straight fitting	01
28	830 1000 0	HP 90 mm piston	01	59	830 1032 0	Washer kit	01
29	600 0080 0	LP 90 mm ring kit	01	60	022 0215 0	HP 1/8" ASME safety valve	01
30				61	830 1099 0	No 3 aftercooler kit	01

* Part available in the market - not sold by Schulz
 Note: HP = high pressure LP = low pressure

INSTALLATION

WIRING PROCEDURE
 D.O.L. STARTER

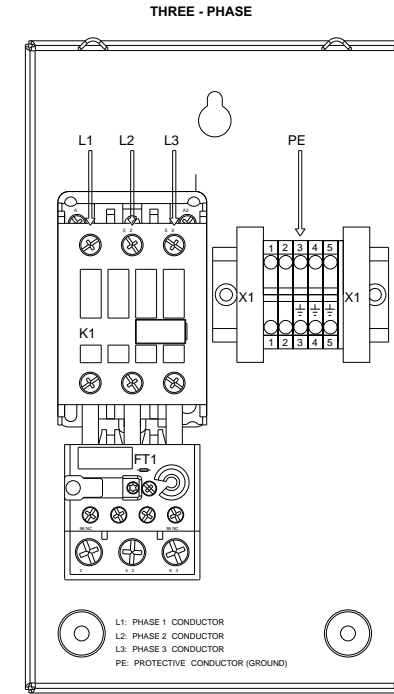

CUSTOMER WIRES LEADS:

MAKE LEADS "L1", "L2", "L3" AND "PE" TO "1 L1", "3 L2", "5 L3" AND "X1 3" RESPECTIVELY, KEEPING THE OTHERS CONDUCTORS;

MANUFACTORY WIRES LEADS:

- "96 NC" CONNECTED TO "A1"
- "5 L3" CONNECTED TO "A2"
- "1 L1" CONNECTED TO "RED BUTTON"
- "RED BUTTON" CONNECTED TO "X1 2"
- "X1 2" CONNECTED TO "PRESSURE SWITCH"
- "PRESSURE SWITCH" CONNECTED TO "X1 1"
- "X1 1" CONNECTED TO "95 NC"
- "X1 4" AND "X1 5" CONNECTED TO "PRESSURE SWITCH" AND "MOTOR"
- "2 T1", "4 T2" AND "6 T3" CONNECTED TO "MOTOR"

WARNING:

TURN OFF POWER BEFORE SERVICING
 COMPRESSOR FLYWHEEL ROTATION SHOULD BE COUNTERCLOCKWISE WHEN FACING FLYWHEEL
 IF COMPRESSOR FLYWHEEL ROTATION IS REVERSED (CLOCKWISE), QUICKLY TURN OFF THE POWER AND DISCONNECT ALL SUPPLY SOURCE AND INTERCHANGE THE "L1" AND "L2" WIRES

NOTE:

The "wiring procedure" is only for reference also "Electrical Diagram" see page 5
 * For the product version in 460V
 The command wiring is carried out by a step down transformer from 460V to 230V as showed on page 5 by "T"

INSTALLATION

WIRING PROCEDURE

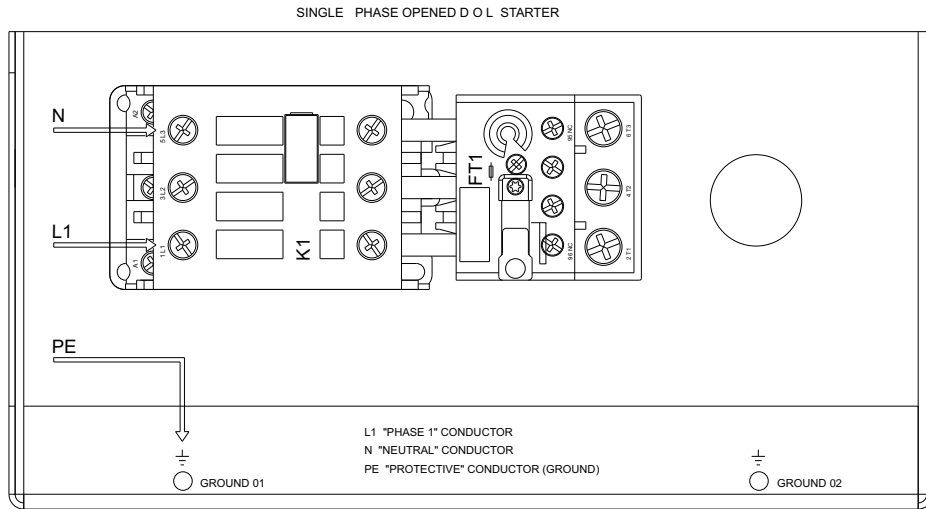

CUSTOMER WIRES LEADS:

MAKE LEADS "L1", "N" AND "PE" TO "1 L1", "5 L3" AND "GROUND 01" RESPECTIVELY, KEEPING THE OTHERS CONDUCTORS;

MANUFACTORY WIRES LEADS:

- "96 NC" CONNECTED TO "A1"
- "5 L3" CONNECTED TO "A2"
- "1 L1" CONNECTED TO "RED BUTTON"
- "RED BUTTON" CONNECTED TO "PRESSURE SWITCH"
- "PRESSURE SWITCH" CONNECTED TO "95 NC"
- "2 T1" CONNECTED TO "3 L2"
- "4 T2" AND "6 T3" CONNECTED TO "MOTOR"
- "GROUND 02" CONNECTED TO "MOTOR"

WARNING:

TURN OFF POWER AND DISCONNECT ALL SUPPLY SOURCE BEFORE SERVICING

TECHNICAL DATA 10120HW40X

AIR COMPRESSOR PARTS

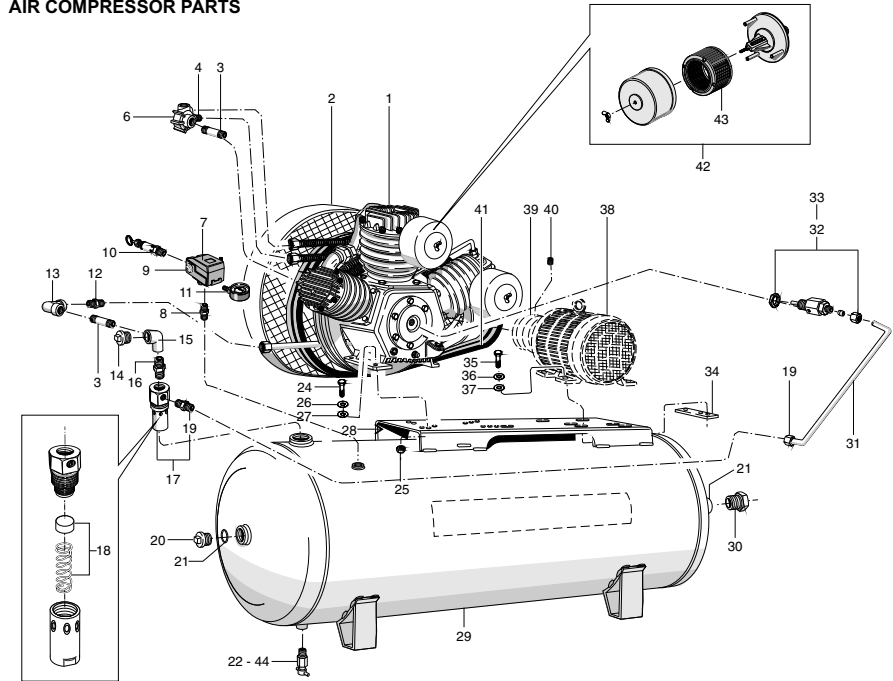

No.	CODE	DENOMINATION	QTY	No.	CODE	DENOMINATION	QTY
1	-	Bare pump	01	24	*	W 1/2 x 1.3/4 hex head bolt	04
2	830.1010-0	Belt guard	01	25	*	BSW 1/2 hex nut	04
3	21011009	3/4 x 100mm nipple	02	26	*	1/2 lock washer	04
4	21011001	NPT 3/4 x 1/2 straight connection	02	27	*	1/2 washer	04
6	20517005	Upper tubing adaptor	01	28	701.0365-0	Support base tank	02
7	012.0845-0	Pressure switch	01	29	25003832A	120 gal hor. tank	01
8	003.0174-4	1/4 nipple	01	30	003.0512-0	2 x 1 reduction bushing	01
9	012.0723-0	Strain relief	01	31	709.1670-0	1/4 tube	01
10	022.0057-0	1/4 ASME safety valve	01	32	022.0174-0	Centrifugal unloading valve	01
11	011.0118-0	Pressure gauge	01	33	830.1043-0	Centrifugal unloading valve kit	01
12	003.0051-9	NPT 3/4 x 3/4 straight connection	02	34	21028503	Motor fastening plate	02
13	60255506	BSP 90° 3/4 elbow	01	35	*	3/8 x 1.1/2 hex head bolt	04
14	003.0031-4	3/4 plug	01	36	*	3/8 lock washer	04
15	003.0343-0	3/4 side elbow	01	37	*	3/8 washer	04
16	003.0036-5	3/4 nipple	01	38	015.0602-0	Motor 208/230/460V (three-phase)	01
17	60281501	Check valve	01	39	709.1675-0	Pulley	01
18	34004508	Check valve kit	01	40	*	5/16 x 3/8 Allen hex without head	02
19	003.0054-3	NPT 1/8 x 1/4 straight connection	01	41	004.0132-0	Belt	02
20	003.0514-0	2 Plug	01	42	809.1085-0	3/4 NPT air filter	02
21	023.0339-0	O ring	02	43	007.0118-0	Filter element	02
22	022.0206-0	1/4 tank drain valve	01	44	709.1246-0	Hose for tank drain (not shown)	01

* Part available in the market - not sold by Schulz.

** Optional start switch

TECHNICAL DATA 10120HW40X

MODEL	DISPLACEMENT		MAX PRESSURE		TANK		Q1	Ø PULLEY		BELT SIZE	ELECTRIC MOTOR		D CHARGE SIZE	OIL CAP		WEIGHT WITH MOTOR		COLOR REF	
	cfm	l m n	psig	bar	Geom	Volume		rpm	inches		mm	2P		hp	kW	VOLTAGE [V]	mi		in qt
10120HW40X	40	1,132	175	12	427	113	710	4.1	105	2-B	10	7.5	Three phase 208/230/460	1"	1,500	1,580	878	397	Black (pump) Gray (tank)

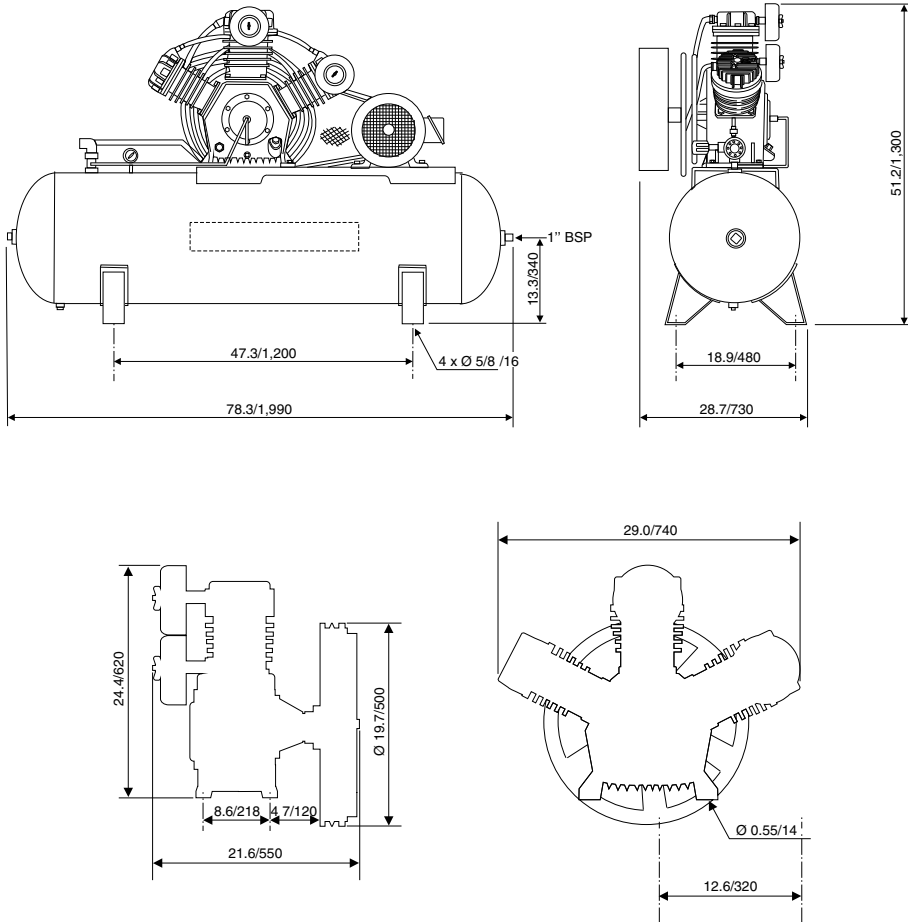

Note: dimensions in inch/mm.

INSTALLATION

AIR DISTRIBUTION NETWORK TYPICAL INSTALLATION DIAGRAM

This diagram is only a guide to a typical air system. Your needs may be different and you should consult a professional for more information regarding your particular installation.

⚠ DANGER **IMPORTANT**
Follow all safety precautions and warnings always turn off and lockout/tagout the main power supply before servicing unit.

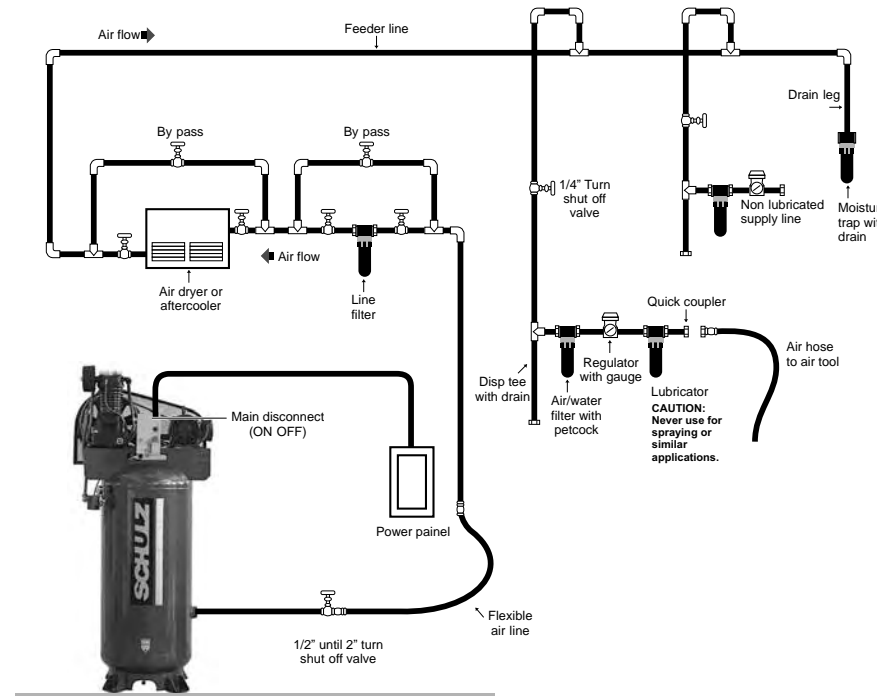

⚠ CAUTION To remove moisture from air line, the main feeder line must run downhill to drain-leg at a rate of 3/4" to 1" every 10'.

⚠ DANGER Recommended pipe and fittings: black iron pipe no smaller than tank outlet size (NPT). For systems over 100 feet in length increase by one pipe size or loop air lines back to receiver.

START-UP CHECKLIST

WARNING Never assume a compressor is safe to work on just because it is not operating. It could restart at any time. Follow all safety precautions and guidelines outlined in this manual.

Go through this checklist **before** you start the compressor for the first time.

WARNING Failure to perform the steps outlined in the start-up checklist, may result in mechanical failure, property damage, serious personal injury or even death.

1. Review Installation parameters in the prior section.

- Double-check these items:
- Distance from walls at least 30".
 - Properly mounted.
 - Flexible coupler between compressor and shop.
 - No toxic, volatile, or corrosive fumes in the area.
 - Correct wire size, fuses, or circuit breakers.

2. Check the oil level in the pump and add if necessary.

3. Check that all pressure relief valves are in place and operational.

4. Check that the air filter is in place and securely mounted.

5. Remove all loose objects and tools around the compressor installation.

6. Open the service valve and any other shut off valves in the air system.

7. On three phase compressors, "bump" the motor to verify that you have the correct rotation (CCW facing the shaft). Reverse if necessary.

BREAK-IN PROCEDURES

After completing the START-UP CHECKLIST you are ready to run the compressor. Always go through this procedure before restarting your unit, if you have moved it to a new location or have had service on the pump or motor.

1. Start the compressor and check for excessive noise or vibration. If there is any condition that appears unsafe, stop the compressor immediately and fix the problem. If the compressor is running normally, allow the unit to pump for ten minutes before closing the service valve and allowing the compressor to pump up and shut off. Check the system for leaks.

2. Pay close attention to the compressor for the first hour of use. It is not necessary to run the compressor "un-loaded" to seat the rings.

3. During the first full day of running the compressor you should note how many times an hour the compressor is starting. During an "average" hour you should check what percent of those 60 minutes the compressor is running. If the compressor starts more than eight times or runs for more than 75 percent of an average hour, you need more air.

TECHNICAL DATA 10120HL40X

BARE PUMP PARTS

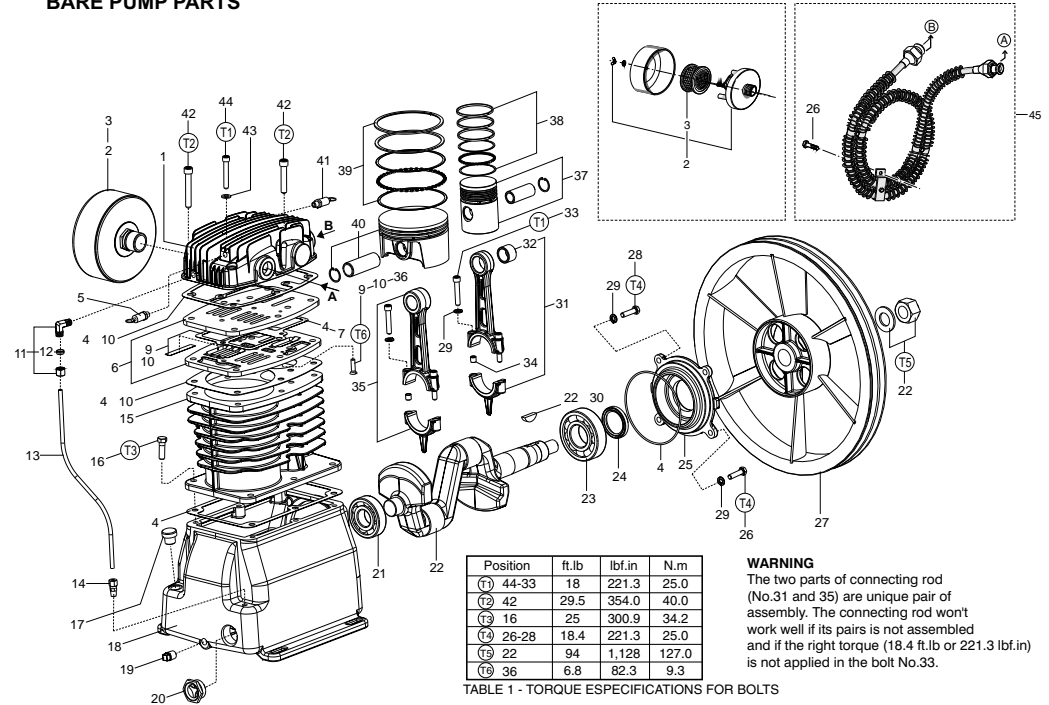

TABLE 1 - TORQUE ESPECIFICATIONS FOR BOLTS

No.	CODE	DENOMINATION	QTY	No.	CODE	DENOMINATION	QTY
1	709.1583-0	Cylinder cover	01	24	60082501	Oil seal	01
2	809.1086-0	1" NPT Air filter	01	25	709.1577-0	Flange	01
3	007.0118-0	Filter element	01	26	709.1611-0	5/16" x 1 1/4" Hex. head bolt**	01
4	830.1090-0/NA	Gasket kit	01	27	709.1611-0	Flywheel	01
5	022.0177-0	LP 1/8" ASME safety valve	01	28	-	5/16" x 1" Hex. head bolt	03
6	809.1061-0	Valve plate	01	29	-	5/16" lock washer	08
7	830.1114-0	Gasket internal plate kit	01	30	709.0147-1	Key	01
9	830.1075-0	Valve plate kit	01	31	830.1093-0	HP connecting rod with needle bearing kit	01
10	830.1076-0	Gasket/valve plate kit (kit)	01	32	019.0028-0	Needle bearing	01
11	003.0005-5	NPT 1/8" x 1/4" elbow	01	33	-	5/16" x 1 3/4" Allen hex. head bolt	04
12	830.0599-8	1/4" ring kit	01	34	809.1082-C	Guide bushing connecting rod	04
13	709.1585-0	Crankcase breather tube	01	35	809.1083-0	LP connecting rod kit	01
14	003.0054-3	NPT 1/8" x 1/4" straight connection	01	36	-	1/4" x 5/8" Flat head bolt	02
15	709.1576-0	Cylinder	01	37	830.1079-0	HP 1/2" piston	01
16	-	3/8" x 1" Hex. head bolt	06	38	830.1078-0	HP 2 1/2" ring kit	01
17	028.0297-0	M18 plug	01	39	830.1091-0	LP 120mm ring kit	01
18	709.1574-0	Crankcase	01	40	016.0121-0	LP 120mm piston	01
19	003.0028-4	1/4" plug	01	41	022.0215-0	HP 1/8" ASME safety valve	01
20	830.0154-2	1" oil level sight	01	42	-	3/8" x 3 Allen hex. head bolt	08
21	019.0007-2	6306 bearing	01	43	830.1083-0	Washer copper kit	01
22	830.1092-0	Crankshaft kit	01	44	-	5/16" x 2" Allen hex. head bolt	02
23	019.0074-0	6308 bearing	01	45	709.1663-0	intercooler kit	01
				46	0030151-5	NPT 3/4" x 3/4" elbow (not shown)	02
				47	21011002	BSP 3/4" x 3/4" straight connection (not shown)	02

* Part available in the market - not sold by Schulz. ** Assembled of the intercooler holder (item 45). Note: HP = high pressure LP = low pressure

TECHNICAL DATA 10120HL40X

AIR COMPRESSOR PARTS

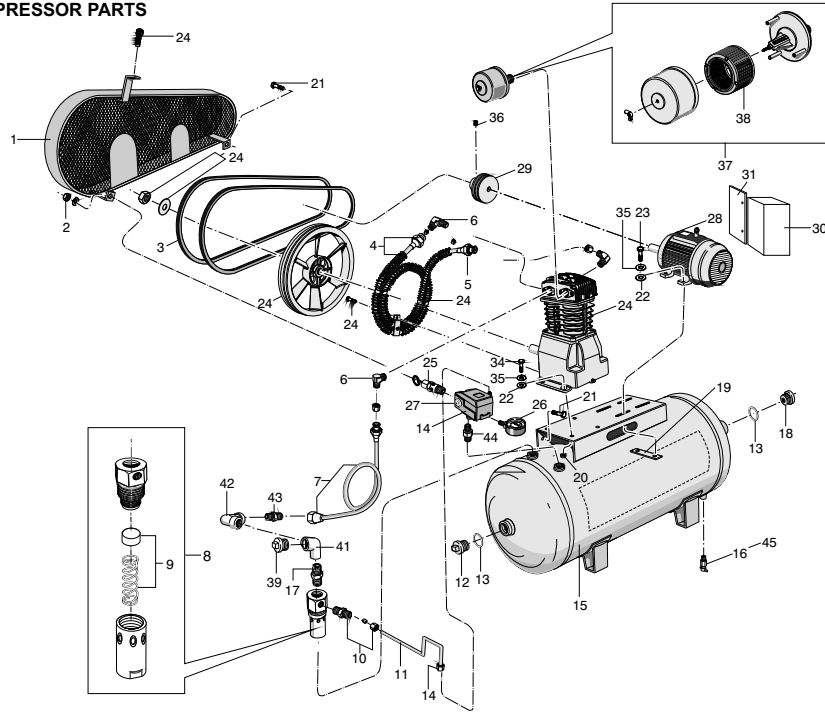

No.	CODE	DENOMINATION	QTY	No.	CODE	DENOMINATION	QTY
1	830.1208-0	Belt guard	01	23	*	3/8 x 1.1/4 hex head bolt	04
2	*	1/4 hex nut	02	24	932.9324-0	Bare pump	01
3	004.0128-0	Belt	02	25	022.0057-0	1/4 ASME safety valve	01
4	709.1663-0	Intercooler	01	26	011.0118-0	Pressure gauge	01
5	21011002	NPT 3/4 straight connection	03	27	012.0723-0	Strain relief	01
6	003.0151-5	BSP 3/4 elbow	03	28	015.0602-0	Motor 208/230/460V (three-phase)	01
7	709.1667-0	Aftercooler	01	29	709.1612-0	Pulley	01
8	60281501	Check valve	01	30	012.0937-0	Start switch**	01
9	34004508	Check valve kit	01	31	701.0379-0	Support start switch**	01
10	003.0005-5	NPT 1/8 x 1/4 elbow	01	32	012.0907-0	Start switch pressure switch cord (not shown)**	01
11	709.1669-0	1/4 Tube	01	33	012.0908-0	Motor start switch cord (not shown)**	01
12	003.0514-0	2 Plug	01	34	*	3/8 x 1.1/2 hex head bolt	04
13	023.0339-0	O ring	02	35	*	3/8 lock washer	08
14	012.0845-0	Pressure switch	01	36	*	3/8 x 1/2 Allen hex without head	01
15	25003832A	120 gal horiz. tank	01	37	809.1086-0	Air filter	01
16	022.0206-0	1/4 tank drain valve	01	38	007.0118-0	Filter element	01
17	003.0036-5	3/4 Nipple	01	39	003.0031-4	3/4 plug	01
18	003.0512-0	2 x 1 Reduction bushing	01	41	003.0343-0	3/4 side elbow	01
19	21028503	Motor fastening plate	02	42	003.0151-5	BSP 90° 3/4 elbow	01
20	*	3/8 hex nut	04	43	21011002	NPT 3/4 x 3/4 straight connection	02
21	*	1/4 x 3/4 hex head bolt	02	44	003.0033-0	1/4 nipple	01
22	*	3/8 Washer	08	45	709.1246-0	Hose for tank drain (not shown)	01

* Part available in the market - not sold by Schulz. ** Optional start switch

BREAK-IN PROCEDURES

- After eight hours of running, check the oil level and look for any oil leaks. Turn the compressor off and bleed down the tank pressure to about 20 psi and open the drain valve to allow all of the moisture to drain from the tank. Allow the pump to cool and torque the head bolts and the bolts which hold the inner and after cooler.
- We recommend that you change your oil after the first 8 hours of operation. This could help remove any small particles in the pump and will improve the life of the pump.
- After the first week of operation follow the guidelines in the MAINTENANCE SCHEDULE.

MAINTENANCE SCHEDULE

THE LIFE OF YOUR COMPRESSOR WILL BE DETERMINED BY HOW IT IS MAINTAINED.

- A clean pump will run cooler, causing less moisture in the tank and lines. Since the cooler the air is, the easier it is to compress, cleaning of the pump will make the motor and pump run less and save you money.
- A clean air filter will allow you to compress more air per cycle. A dirty air filter causes the oil from the crankcase to be sucked up past the piston rings if happens you get MAJOR problems. First, the oil gets into your air system, mixes with the water vapor in the lines and creates a "mayonnaise" that can foul up tools and destroy paint systems with "fish eye". Secondly, the oil becomes baked onto the valve plates where it builds up and cuts the efficiency of the pump dramatically.
- Clean oil at the proper level in the crankcase is your best insurance against pump failure.
- A dry tank will last many more years than a tank with water sitting in it rusting away metal. The tank is a great heat sink and will take out the bulk the moisture that is in your air system if you drain it.

WARNING

Turn off power before servicing and be sure the air tank is unloaded. These instructions are based on normal operating conditions. If the compressor is located in an exceedingly dusty area, increase the frequency of all inspections.

DAILY

- Inspect the compressor visually.
- Check oil level and add some if necessary, before turning the compressor on.
- Drain moisture from the piping system.
- Be sure there is no excessive or unusual vibration or noise.

WEEKLY

- Remove and clean intake air filters; do not wash the filter element.
- Check V-belt for tightness. Belt tension should be adjusted to allow approximately 3/8" to 1/2" (9 to 13 mm) deflection with normal thumb pressure, see Figure page 16.
- Clean cylinders externally, cylinder head, motor, fan blade, tubing, and tank.
- ASME safety valve should be tested manually to see if it is working properly.

MONTHLY

- Check entire system for air leakage around fittings, etc by using water and soap lather.
- Check the pressure switch operation.
- Check for oil contamination and change it if necessary.

MAINTENANCE SCHEDULE

QUARTERLY

- Change the air filter element every 300 working hours or quarterly. (Whichever occurs first).
- Fasten bolts and nuts as required.
- Change oil more frequently if compressor is located in a very dirty environment.
- **WHILE RUNNING IN A PERIOD OF ABOUT 100 WORKING HOURS THE OIL LEVEL SHOULD BE CAREFULLY CHECKED.**

ANNUALLY

- Test and calibrate the pressure switch, pressure gauge and ASME safety valve according to their own technical standards. These parts must be removed from the tank and pump to be tested.
- Inspect and clean the suction and discharge valve(s) plate(s) every 1000 (one thousand) working hours (whichever occurs first), located between the cylinder and its cover and, if necessary, replace it (them) according to the operation conditions.

LUBRICATION

- The first oil change should be made after 8 hours of operation.
- The second oil change after 40 hours of operation.
- The third and following oil changes should be made after 200 hours of operation, or 60 (sixty) days, whichever occurs first.

NOTE:

Heavy Duty and mul i-viscous oils are not adequate for Schulz air compressor's lubrication. The same applies to oils that tend to emulsify. We recommend good industrial oil for air compressors, with rust and oxidation inhibitors and high viscosity level (from 90 to 95), SAE or ISO, as indicated in the table below:

SERVICE PROCEDURES

WARNING Never assume a compressor is safe to work on just because it is not operating. It could restart at any time. Follow all safety precautions and guidelines outlined in this manual.

CRANKCASE OIL - The oil level should be half way to three quarters up the sight gauge when the compressor is stopped. Do not over fill or check the oil level while the pump is running. Compressor must be level.

Use *non-detergent*, petroleum based, compressor or automotive grade oil only. Detergent or synthetic oil can damage the pump, cause excessive leaks, and will void the warranty. **DO NOT USE SYNTHETIC OIL IN THIS PUMP!**

RECOMMENDED LUBRICANT OILS FOR SCHULZ AIR PUMPS

AMBIENT TEMPERATURE °F (°C)		
Below 32 °F Below 0 °C	32 °F to 68 °F 0 °C to 20 °C	68 °F to 104 °F 20 °C to 40 °C
SAE 10W or ISO 32	SAE 20W or ISO 68	SAE 30 or ISO 100

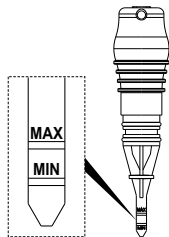

TECHNICAL DATA 10120HL40X

MODEL	DISPLACEMENT		MAX PRESSURE		TANK		rpm	Ø PULLEY		BELT SIZE	ELECTRIC MOTOR		DISCHARGE SIZE	OIL CAP		WEIGHT WITH MOTOR		COLOR REF	
	cfm	l/min	psig	bar	Geom Volume			2P			hp	kW		VOLTAGE [V]	Volume		lbs		Kg
					gal	l		inches	mm						ml	in qt			
10120HL40X	40	1,132	175	12	427	113	1,020	5.9	150	2-A	10	7.5	Three phase 208/230/460	1"	1,500	1,580	596	270	Black (pump) Gray (tank)

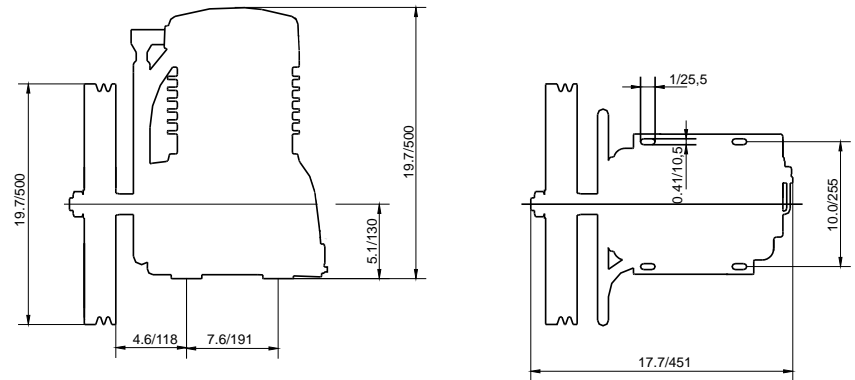
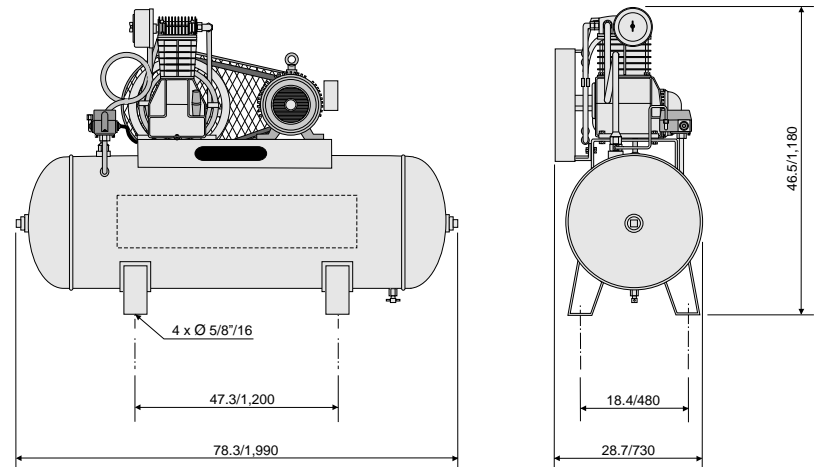

Note: dimensions in inch/mm.

TECHNICAL DATA 7.580HV30X

BARE PUMP PARTS

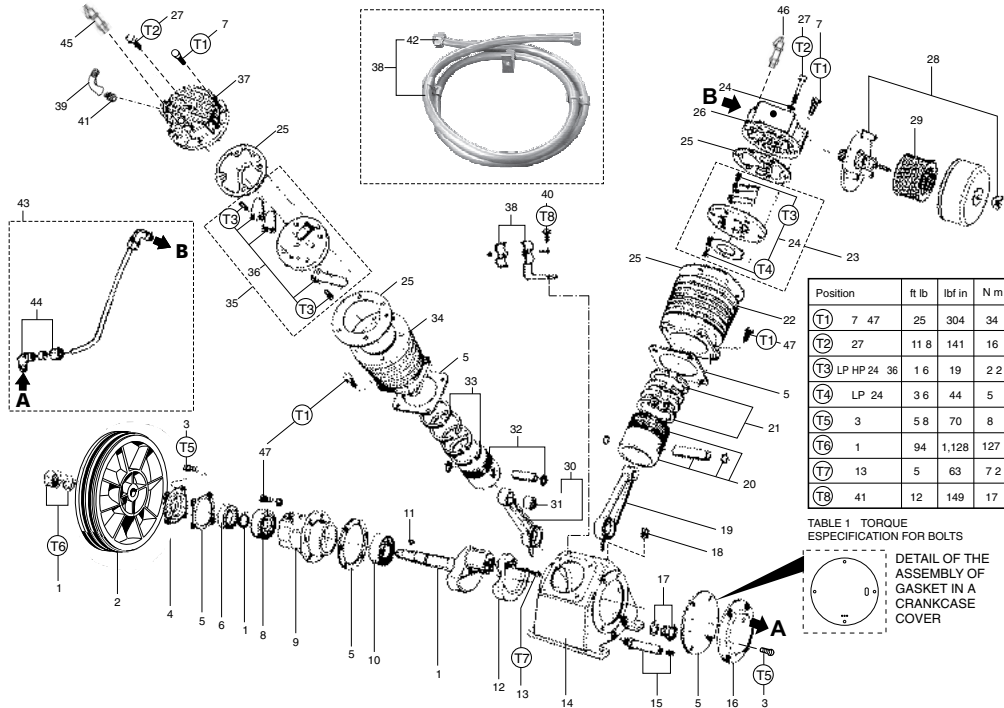

Position	ft lb	lbf in	N m
(T1)	7 47	25 304	34
(T2)	27	11 8	141 16
(T3) LP HP	24 36	1 6 19	2 2
(T4) LP	24	3 6 44	5
(T5)	3	5 8 70	8
(T6)	1	94 1,128	127
(T7)	13	5 63	7 2
(T8)	41	12 149	17

TABLE 1 TORQUE SPECIFICATION FOR BOLTS
DETAIL OF THE ASSEMBLY OF GASKET IN A CRANKCASE COVER

No.	CODE	DENOMINATION	QTY	No.	CODE	DENOMINATION	QTY
1	830 0609 9	Crankshaft	01	25	830 0956 0/NA	Upper gasket kit	01
2	709 1277 0	Flywheel	01	26	709 1272 0	LP 120mm cylinder cover	01
3	*	UNC 1/4" x 3/4" LT head bolt	08	27	M6 x 1,0 x 55 Allen head bolt	03	
4	709 0139 0	Flange cover	01	28	809 1085 0	Air filter	01
5	830 0954 0/NA	Crankcase gasket kit	01	29	007 0118 0	Filter element	01
6	023 0099 0	Oil seal	01	30	830 0632 0	HP connecting rod with needle bearing	01
7	*	UNC 3/8" x 1 1/2" LT head bolt	11	31	019 0028 0	Needle bearing	01
8	019 0006 4	6208 bearing	01	32	830 0608 0	HP Ø 2 1/2" piston	01
9	709 1221 0	Flange	01	33	830 0982 0	HP 2 1/2" ring kit	01
10	382 0028 3	6309 bearing	01	34	709 1193 0	HP 2 1/2" cylinder	01
11	709 0147 1	Key	01	35	809 1029 0	HP 2 1/2" valve plate	01
12	709 0930 8	Counter weight	01	36	830 0957 0	HP valve plate kit	01
13	013 0467 4	UNC 3/16" x 7/8" LT Allen head bolt	02	37	709 1389 0	HP 2 1/2" cylinder cover	01
14	709 1191 0	Crankcase	01	38	709 0283 4	Intercooler kit	01
15	830 0205 0	Oil drain tube	01	39	003 0111 6	90° MF 3/4" elbow	02
16	709 1273 0	Crankcase cover	01	40	UNC 5/16" x 5/8" LT head bolt	01	
17	830 0775 0	3/4" oil level sight	01	41	21011 002	3/4" x 3/4" straight connection	02
18	003 0028 4	1/4" plug	01	42	21011 004	3/4" nut for intercooler	02
19	709 0732 1	LP connecting rod	01	43	830 0340 5	Crankcase breather tube	01
20	016 0004 4	LP Ø 120mm piston	01	44	003 0005 5	NPT 1/8" x 1/4" elbow	02
21	830 0981 0	LP 120mm ring kit	01	45	022 0215 0	HP 1/8" ASME safety valve	01
22	709 1192 0	LP 120mm cylinder	01	46	022 0177 0	LP 1/8" ASME safety valve	01
23	809 1028 0	LP 120mm valve plate	01	47	*	UNC 3/8" x 1" LT head bolt	14
24	830 0955 0	LP valve plate kit	01				

* Part available in the market - not sold by Schulz.

HP = high pressure LP = low pressure

MAINTENANCE SCHEDULE

Change the oil when the compressor is warm so that the oil will drain out of the crankcase easier. Carefully open the plug on the crankcase drain, open the ball valve and drain the oil into a suitable container. Remove the crankcase fill plug to make the oil flow out faster. Allow the crankcase to drain completely. Replace the plug, and fill the crankcase to the proper level. Check the level carefully after the first day of use. Please recycle the used oil.

CAUTION Never attempt to change or fill the oil while the compressor is running. Do not work on the pump while it is hot as some parts of the pump can cause severe burns to unprotected skin. Never use flammable solvents to clean the pump or the intake system.

AIR FILTER - To service the air filter, remove the wing nut and cover that hold the element on to the intake assembly. Inspect the element and clean or replace as needed. Paper filters can be tapped out and back flushed with low-pressure air several times before they must be replaced. Fiber (Micronite) filters can be washed out with soapy water, rinsed, and reused until the element material starts to deteriorate. Never use solvents to clean the filter or inlet parts. Always keep extra filter elements on hand. NEVER RUN THE COMPRESSOR WITHOUT A FILTER. Clean all parts and re-assemble in reverse order.

DRAIN THE TANK - To drain the moisture from the tank you should first reduce the air pressure in the tank and air lines to a safe pressure, around 20 psi. Open the drain valve and drain the moisture into a suitable container for disposal. All piston pumps have some level of oil bypass the rings and get pumped into the tank. This oil is measured in parts per million (PPM) and mixes with the moisture in the tank to form a whitish "mayonnaise" like substance. Check with local codes concerning the discharge of this fluid directly into the sewer system.

Compressors used in commercial applications should be drained at least once a day. If you only run your compressor occasionally, it should be drained after each time you use it. Shops that run multiple shifts a day should have automatic drains to help reduce the moisture build up in the tank. A 5 HP compressor can dump as much as a gallon of moisture a day into the tank.

VALVES - The compressor pump has a set of reed valves manufactured from the highest quality stainless steel. These valves and the valve plates that hold them in place need to be maintained in order for the pump to work at its normal capacity. Once the valves become caked with carbonized dirt and oil they lose their ability to open and close properly and the amount of air that the compressor can make is dramatically compromised. Before starting this maintenance procedure you should make sure that you have a set of the gaskets you need to replace when you open up the pump.

1. Remove the air inlet assembly, inter cooler, and after cooler from the cylinder head of the pump.
2. Remove the cylinder head bolts after loosening all of them evenly, from the center out.
3. Remove the cylinder head and valve plates from the cylinder. Separate the head from the valve plates taking care to note the position of the valve plates for re-assembly. Use caution when separating the parts as the gaskets may be stuck together. Inspect the condition of the cylinder and piston for damage.
4. Clean the valves and valve plates with a stiff bristle brush or other suitable device. Do not use a steel wire brush as severe damage may result to the valve seat or valve.
5. Use clean safety solvent to loosen carbon deposits. NEVER use gasoline, thinners or other flammable solutions to clean valves or related parts. Remove all broken or defective gasket material.
6. To re-assemble the valve plates, a small amount of light grease or petroleum jelly can be used on clean, dry surfaces to hold the reed valves in place while they are assembled. Reserve the order to complete this operation and follow the recommended torque settings for the head bolts. Use a crosshatch pattern when tightening the head bolts.
7. Turn the pump over by hand several revolutions to make sure there are no problems. Review the START-UP CHECKLIST and follow the recommended BREAK-IN PROCEDURES. Re-torque the head bolts and check for leaks after one hour of running.

MAINTENANCE SCHEDULE

BELT TENSION - Proper belt tension and pulley alignment must be maintained for maximum drive efficiency and belt life. The correct tension exists if a deflection of 1/2" occurs by placing 10 pounds of force midway between the motor pulley and the pump flywheel. See figure below. This deflection can be adjusted using the following procedure.

1. Remove belt guard.
2. Loosen the motor mounting bolts. Remove belts.
3. Shift the motor to the point where the correct tension exists.
4. Retighten motor mounting bolts. Replace belts.
5. Check the tension again.
6. Replace the belt guard.

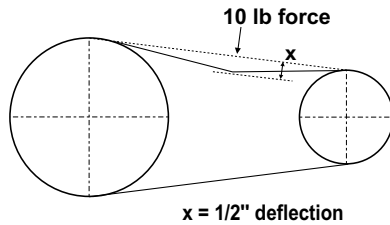

WARNING Do not operate the compressor with any of its safety guards, shields, or screens removed. Never cause the compressor to run at speeds in excess of the factory set RPM. Always follow all safety precautions and warnings when performing service.

PULLEY ALIGNMENT - Three examples of pulley misalignment are shown below. To check the pulley alignment, remove the belt guard and place a straight edge against the pump flywheel. Measure the distance from the straight edge to the motor pulley at several points. If the pulley needs to be adjusted, follow the procedure below.

1. Loosen the motor mounting bolts.
2. Loosen the setscrews on the motor pulley.
3. Align the motor pulley using the straight edge as a guide.
4. Retighten the motor pulley setscrew using thread-locking fluid.
5. Adjust the belt tension as described previously.
6. Retighten the motor mounting bolts.
7. Replace the belt guard and test.

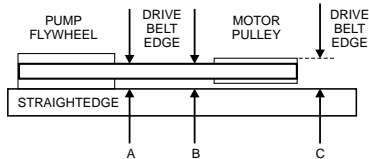
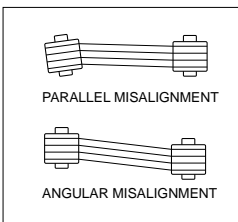

TECHNICAL DATA 7.580HV30X

MODEL	DISPLACEMENT		MAX PRESSURE		TANK		Q ₁	Ø PULLEY		BELT SIZE	ELECTRIC MOTOR		DISCHARGE SIZE	OIL CAP		WEIGHT WITH MOTOR		COLOR REF
	cfm	l/min	psig	bar	Geom	Volume		rpm	inches		mm	hp		VOLTAGE [V]	ml	in qt	lbs	
7.580HV30X	30	850	175	12	300	80	960	9.0	226	2-A	7.5	5.6	1/2"	0,880	0,920	508	230	
								4.5	115									

Compressor dimension (inch/mm)
Height 42 7/1,085, length 55 1/4,000, width 25 2 / 640

AIR COMPRESSOR PARTS

4 x Ø 5/8 x 27 5 / 700 x 18 9

Note: dimensions in inch/mm.

No.	CODE single-phase	CODE three-phase	DENOMINATION	QTY
1	-	-	Bare pump	01
2	830.1222-0	830.1222-0	Belt guard	01
3	709.1228-0	709.1228-0	Aftercooler	01
4	012.0845-0	012.0845-0	Pressure switch	01
5	011.0114-0	011.0114-0	Pressure gauge	01
6	709.1679-0	709.1679-0	1/4" tube	01
7	022.0213-0	022.0213-0	Check valve	01
8	022.0162-0	022.0162-0	1/4" ASME safety valve	01
9	25003837	25003837	80 gal vertical tank	01
10	022.0206-0	022.0206-0	1/4" tank drain valve	01
11	709.1246-0	709.1246-0	Hose for tank drain (not shown)	01
12	-	015.0583-0	Motor 208/230/460V 2P	01
13	015.0616-0	-	Motor 230V 4P	01
14	709.0928-0	-	Pulley 4P	01
15	-	709.1661-0	Pulley 2P	01
16	004.0125-0	004.0110-0	Belt	02
17	*	*	3/8 x 1.1/2 hex head	04
18	*	*	3/8 x 1.1/4 hex head	04
19	*	*	3/8 hex nut	04
20	003.0174-4	003.0174-4	1/4" nipple	01
21	21028503	21028503	Motor fastening plate	02

* Part available in the market - not sold by Schulz.

TECHNICAL DATA 7.580VV30X

BARE PUMP PARTS

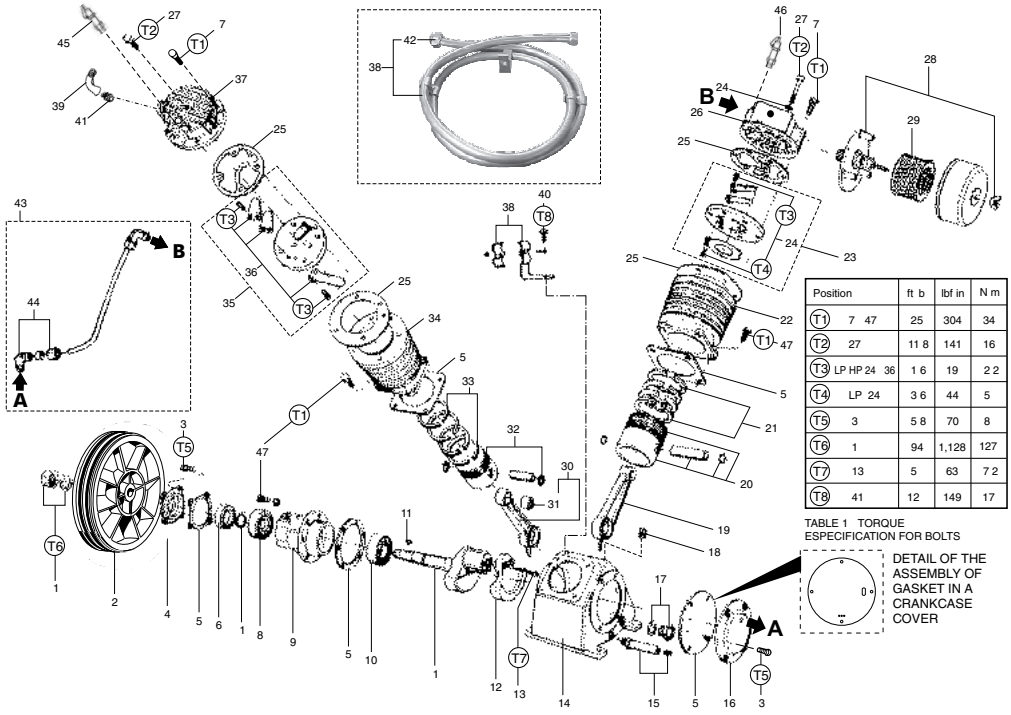

Position	ft lb	lb/in	N m
T1	7 47	25 304	34
T2	27	11 8	141 16
T3	LP HP 24 36	1 6	19 2 2
T4	LP 24	3 6	44 5
T5	3	5 8	70 8
T6	1	94	1,128 127
T7	13	5 63	7 2
T8	41	12 149	17

TABLE 1 TORQUE SPECIFICATION FOR BOLTS
DETAIL OF THE ASSEMBLY OF GASKET IN A CRANKCASE COVER

No.	CODE	DENOMINATION	QTY	No.	CODE	DENOMINATION	QTY
1	830 0609 9	Crankshaft	01	25	830 0956 0/NA	Upper gasket kit	01
2	709 1277 0	Flywheel	01	26	709 1272 0	LP 120mm cylinder cover	01
3	*	UNC 1/4" x 3/4" LT head bolt	08	27	*	M6 x 1,0 x 55 Allen head bolt	03
4	709 0139 0	Flange cover	01	28	809 1085 0	Air filter	01
5	830 0954 0/NA	Crankcase gasket kit	01	29	007 0119 0	Filter element	01
6	023 0099 0	Oil seal	01	30	830 0632 0	HP connecting rod with needle bearing	01
7	*	UNC 3/8" x 1 1/2" LT head bolt	11	31	019 0028 0	Needle bearing	01
8	019 0006 4	6208 bearing	01	32	830 0608 0	HP Ø 2 1/2" piston	01
9	709 1221 0	Flange	01	33	830 0982 0	HP 2 1/2" ring kit	01
10	392 0029 3	6309 bearing	01	34	709 1193 0	HP 2 1/2" cylinder	01
11	709 0147 1	Key	01	35	809 1029 0	HP 2 1/2" valve plate	01
12	709 0930 8	Counter weight	01	36	830 0957 0	HP valve plate kit	01
13	013 0467 4	UNC 3/16" x 7/8" LT Allen head bolt	02	37	709 1389 0	HP 2 1/2" cylinder cover	01
14	709 1191 0	Crankcase	01	38	709 0283 4	Intercooler kit	01
15	830 0205 0	Oil drain tube	01	39	003 0111 6	90° MF 3/4" elbow	02
16	709 1273 0	Crankcase cover	01	40	UNC 5/16" x 5/8" LT head bolt	01	
17	830 0775 0	3/4" oil level sight	01	41	3/4" x 3/4" straight connection	02	
18	003 0028 4	1/4" plug	01	42	21011002	3/4" nut for intercooler	02
19	709 0732 1	LP connecting rod	01	43	830 0340 5	Crankcase breather tube	01
20	018 0004 4	LP Ø 120mm piston	01	44	003 0005 5	NPT 1/8" x 1/4" elbow	02
21	830 0981 0	LP 120mm ring kit	01	45	022 0215 0	HP 1/8" ASME safety valve	01
22	709 1192 0	LP 120mm cylinder	01	46	022 0177 0	LP 1/8" ASME safety valve	01
23	809 1028 0	LP 120mm valve plate	01	47	*	UNC 3/8" x 1" LT head bolt	14
24	830 0955 0	LP valve plate kit	01				

* Part available in the market - not sold by Schulz.

HP = high pressure LP = low pressure

TROUBLESHOOTING

TROUBLE	POSSIBLE CAUSE	CORRECTIVE ACTION
Compressor will not start	No electrical power	Check or have system checked
	Tank pressure is between starting and stopping pressures	Wait until pressure drops
Motor overheats, blows fuses or overload relay cuts out	Wrong fuse size	Replace with correct size
	High ambient temperature	Provide ventilation. Check distance from the wall
	Wrong wire size	Have electrical system checked
	Thermal overload tripped	Allow to cool and reset overload relay
	One leg of supply line interrupted	Check all fuses and terminals for tightness. Check each leg
Pump using too much oil	Air filter dirty	Clean or replace element
	Oil level too high	Do not overfill crankcase
	Breather valve malfunctioning	Check valve and fix if broken
	Piston rings worn or broken	Check rings and replace if necessary
	Oil leaks	Tighten pump bolts or replace leaking gaskets
	Wrong oil viscosity, synthetic oil	Drain and refill with proper oil
Tank does not hold pressure	Diaphragm in pressure switch defective	Replace pressure switch
	Leaking fittings	Check for leaks and tighten
Compressor starts more than seven times per hour	High moisture level in tank	Drain tank
	Check valve leaks	Drain air. Remove and fix
	Pressure switch set incorrectly	Check cut in and cut out setting
	Excessive air requirements	Decrease shop consumption by installing a regulator. Add another compressor to supply
	Leaks in air system	Inspect air system and fix
Compressor takes too long to fill tank	Excessive air requirement	Determine if compressor is properly sized for job
	Compressor not in optimal condition	Perform maintenance, check for loose belts, dirty air filter
	Dirty, sticking or damaged valves	Remove cylinder head and clean, replace damaged reed valves and gaskets
Compressor vibrates	Compressor not properly installed	Level the tank feet with vibration isolators and shims
	Mounting bolts too loose	Torque mounting bolts evenly
	Pulley and flywheel mis-aligned	Realign per manual
	Belts loose	Tighten per manual

TROUBLESHOOTING

TROUBLE	POSSIBLE CAUSE	CORRECTIVE ACTION
Oil in discharge air	Compressor air intake restricted	Clean or replace filter element
	Excessive oil in the crankcase	Drain level to mid sight glass/dipstick, see Figure page 14
	Wrong oil viscosity	Drain pump and refill with the proper oil
	Worn rings	Replace rings
	Crankcase breather valve sticking	Clean or replace
Water in the crankcase Oil appears milky	Compressor not running long enough to vaporize the water	Allow the compressor to run enough each day to vaporize the water
Compressor leaks down when off	Pressure switch diaphragm leaking	Replace pressure switch
	Check valve leaking	Drain tank, remove, clean and check valve. Replace if defective
	Fitting or valve leaking	Check for leaks and fix problem

LIMITED WARRANTY

Limited Warranty

Bare Pumps and Air Compressors manufactured by SCHULZ are warranted to be free from defects in material and workmanship under normal use for a period of 2 years on the pumps and 1 year on the remaining items, from date of purchase of the end user, except the Contractor Line of Products and all Gasoline Engine driven products. The warranty on contractor/engine driven models is 3 months. A proof of purchase must be provided by the user to receive service under warranty. This warranty is extended to original purchaser for use of the SCHULZ product (only) and is not transferable.

Where to repair product under Warranty

Only the Schulz Authorized Retail Store where the product was purchased can provide warranty services. Any service performed by a non authorized service person, voids the warranty. Engines must be taken to the proper factory authorized service center, i.e. Briggs & Stratton, Honda, Kohler, Robin.

What is covered under Warranty

Materials, parts and labor to repair the product are covered by this warranty. For products of 5HP and over, travel/mileage expenses are allowed. See limitations.

What is not covered by Warranty

Defects and damages from failure to perform factory suggested maintenance, wrong application, excessive wear and tear and rental use. Freight is not covered under warranty. Any loss of "shop time" is not covered by this warranty. Warranty is not to be considered a free maintenance program.

TECHNICAL DATA 7.580VV30X

MODEL	DISPLACEMENT		MAX. PRESSURE		TANK		Q1	Ø PULLEY		BELT SIZE	ELECTRIC MOTOR		DISCHARGE SIZE	OIL CAP		WEIGHT W TH MOTOR		COLOR REF
	cfm	l/min	psig	bar	Geom	Volume		hp	kw		VOLTAGE [V]	ml		in qt	lbs	Kg		
7.580VV30X	30	850	175	12	300	80	960	9.0	226	2-A	7.5	5.6	1/2"	0,880	0,920	508	230	Black (pump) Gray (tank)
								4.5	115									

Compressor dimension (inch/mm)
Height 74 8/1,900, length 39 3/1,000, width 25 2 / 640

AIR COMPRESSOR PARTS

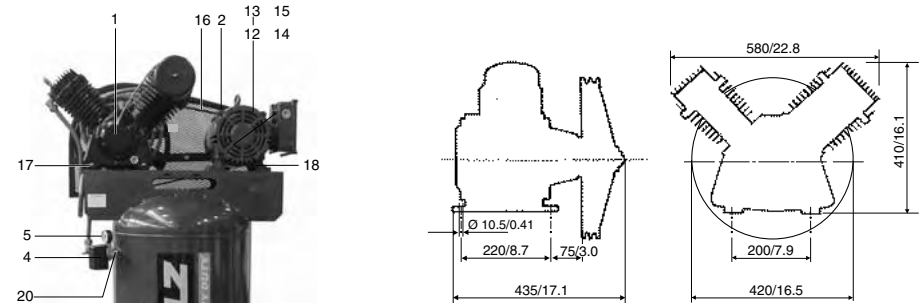

Note: dimensions in inch/mm.

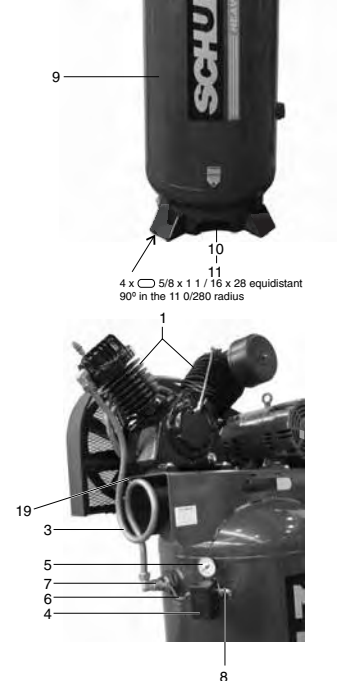

No.	CODE single-phase	CODE three-phase	DENOMINATION	QTY
1	-	-	Bare pump	01
2	830.1222-0	830.1222-0	Belt guard	01
3	709.1657-0	709.1657-0	Aftercooler	01
4	012.0845-0	012.0845-0	Pressure switch	01
5	011.0114-0	011.0114-0	Pressure gauge	01
6	709.1650-0	709.1650-0	1/4 tube	01
7	022.0213-0	022.0213-0	Check valve	01
8	022.0162-0	022.0162-0	1/4 ASME safety valve	01
9	25003775A	25003775A	80 gal vertical tank	01
10	022.0206-0	022.0206-0	1/4 tank drain valve	01
11	709.1246-0	709.1246-0	Hose for tank drain (not shown)	01
12	-	015.0583-0	Motor 208/230/460V 2P	01
13	015.0616-0	-	Motor 230V 4P	01
14	709.0928-0	-	Pulley 4P	01
15	-	709.1661-0	Pulley 2P	01
16	004.0125-0	004.0110-0	Belt	02
17	*	*	3/8 x 1.1/4 hex head	04
18	*	*	3/8 x 1.1/2 hex head	04
19	*	*	3/8 hex nut	04
20	003.0174-4	003.0174-4	1/4 nipple	01

* Part available in the market - not sold by Schulz.

TECHNICAL DATA 7.580VL30X

BARE PUMP PARTS

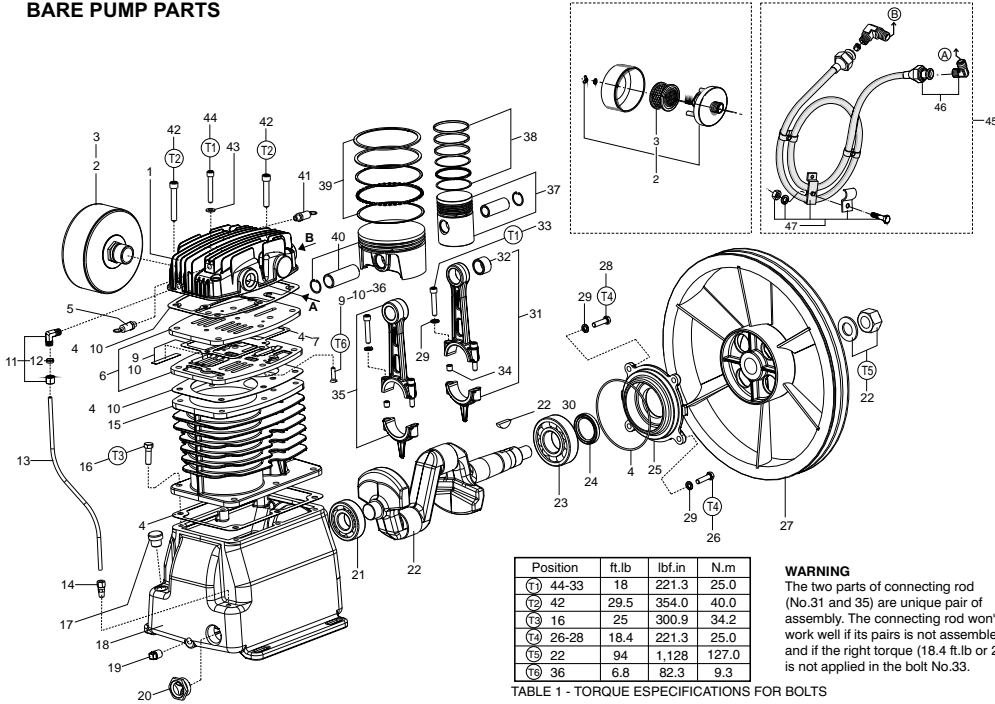

Position	ft.lb	lbf.in	N.m
(T1) 44-33	18	221.3	25.0
(T2) 42	29.5	354.0	40.0
(T3) 16	25	300.9	34.2
(T4) 26-28	18.4	221.3	25.0
(T5) 22	94	1,128	127.0
(T6) 36	6.8	82.3	9.3

TABLE 1 - TORQUE SPECIFICATIONS FOR BOLTS

WARNING

The two parts of connecting rod (No.31 and 35) are unique pair of assembly. The connecting rod won't work well if its pairs is not assembled and if the right torque (18.4 ft.lb or 221.3 lbf.in) is not applied in the bolt No.33.

No.	CODE	DENOMINATION	QTY
1	709.1583-0	Cylinder cover	01
2	809.1086-0	1" NPT Air filter	01
3	007.0118-0	Filter element	01
4	830.1090-0/NA	Gasket kit	01
5	022.0177-0	LP 1/8" ASME safety valve	01
6	809.1061-0	Valve plate	01
7	830.1114-0	Gasket internal plate kit	01
9	830.1075-0	Valve plate kit	01
10	830.1076-0	Gasket/valve plate kit (kit)	01
11	003.0005-5	NPT 1/8" x 1/4" elbow	01
12	830.0599-8	1/4" ring kit	01
13	709.1585-0	Crankcase breather tube	01
14	003.0054-3	NPT 1/8" x 1/4" straight connection	01
15	709.1576-0	Cylinder	01
16	028.0297-0	3/8" x 1" Hex. head bolt	06
17	028.0297-0	M18 plug	01
18	709.1574-0	Crankcase	01
19	003.0028-4	1/4" plug	01
20	003.0044-6	1" oil level sight	01
21	019.0007-2	6306 bearing	01
22	830.1092-0	Crankshaft kit	01
23	019.0074-0	6308 bearing	01
24	60082501	Oil seal	01

No.	CODE	DENOMINATION	QTY
25	702.1577-0	Flange	01
26	516" x 1,1/4" Hex. head bolt**		01
27	709.1405-0	Flywheel	01
28	516" x 1" Hex. head bolt		03
29	516" lock washer		08
30	709.0147-1	Key	01
31	830.1093-0	HP connecting rod with needle bearing kit	01
32	019.0028-0	Needle bearing	01
33	516" x 1,3/4" Allen hex. head bolt		04
34	809.1082-C	Guide bushing connecting rod	01
35	809.1083-0	LP connecting rod kit	01
36	1/4" x 5/8" Flat head bolt		02
37	830.1079-0	HP Ø 2, 1/2" piston	01
38	830.1078-0	HP 2, 1/2" ring kit	01
39	830.1091-0	LP 120mm ring kit	01
40	016.0121-0	LP Ø 120mm piston	01
41	022.0215-0	HP 1/8" ASME safety valve	01
42	3/8" x 3" Allen hex. head bolt		08
43	830.1083-0	Washer copper kit	01
44	516" x 2" Allen hex. head bolt		02
45	709.1592-0	Intercooler kit	01
46	003.0293-0	NPT 3/4" x 3/4" elbow	02
47	830.1084-0	Intercooler holder kit	01

* Part available in the market - not sold by Schulz. ** Assembled of the intercooler holder (item 47).
Note: HP = high pressure LP = low pressure

TECHNICAL DATA 360VL15X

MODEL	DISPLACEMENT		MAX PRESSURE		TANK		Q1'	Ø PULLEY		BELT SIZE	ELECTRIC MOTOR		DISCHARGE SIZE	OIL CAP		WEIGHT WITH MOTOR		COLOR REF	
	cfm	l/min	psig	bar	Geom	Volume		rpm	2P		1-A	hp		kw	VOLTAGE [V]	ml	in qt		lbs
360VL15X	15	425	125	8.6	224	60	1,200	4.2	108	1-A	3	2.2	Single phase 220	1/2"	0.520	0.540	253	115	Black (pump) Gray (tank)

Compressor dimension (inch/mm)
Height 69 3 / 1,760, length 23 5 / 600, width 20 4 / 520

AIR COMPRESSOR PARTS

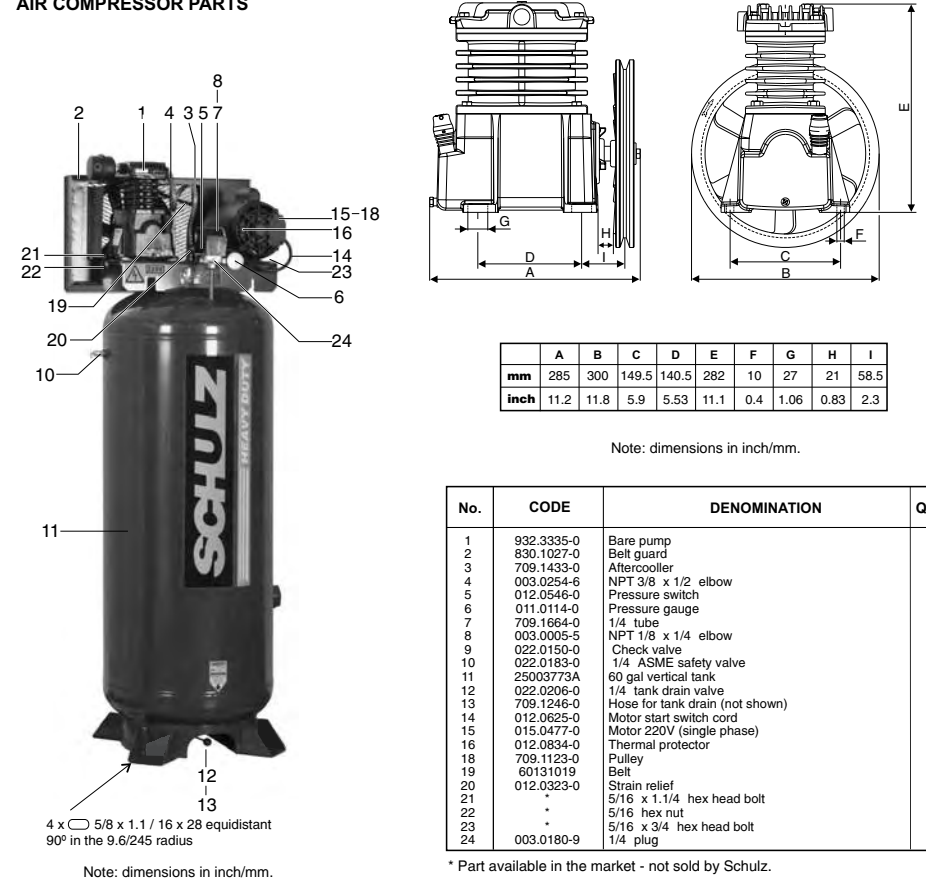

	A	B	C	D	E	F	G	H	I
mm	285	300	149.5	140.5	282	10	27	21	58.5
inch	11.2	11.8	5.9	5.53	11.1	0.4	1.06	0.83	2.3

Note: dimensions in inch/mm.

No.	CODE	DENOMINATION	QTY
1	932.3335-0	Bare pump	01
2	830.1027-0	Belt guard	01
3	709.1433-0	Aftercooler	01
4	003.0254-6	NPT 3/8 x 1/2 elbow	01
5	012.0546-0	Pressure switch	01
6	011.0114-0	Pressure gauge	01
7	709.1664-0	1/4 tube	01
8	003.0005-5	NPT 1/8 x 1/4 elbow	01
9	022.0150-0	Check valve	01
10	022.0183-0	1/4 ASME safety valve	01
11	25003773A	60 gal vertical tank	01
12	022.0206-0	1/4 tank drain valve	01
13	709.1246-0	Hose for tank drain (not shown)	01
14	012.0625-0	Motor start switch cord	01
15	015.0477-0	Motor 220V (single phase)	01
16	012.0834-0	Thermal protector	01
17	709.1123-0	Pulley	01
18	60131019	Belt	01
19	012.0323-0	Strain relief	01
20	516 x 1.1/4"	hex head bolt	04
21	516	hex nut	08
22	516	x 3/4 hex head bolt	04
23	003.0180-9	1/4 plug	02

* Part available in the market - not sold by Schulz.

TECHNICAL DATA 360VL15X

BARE PUMP PARTS

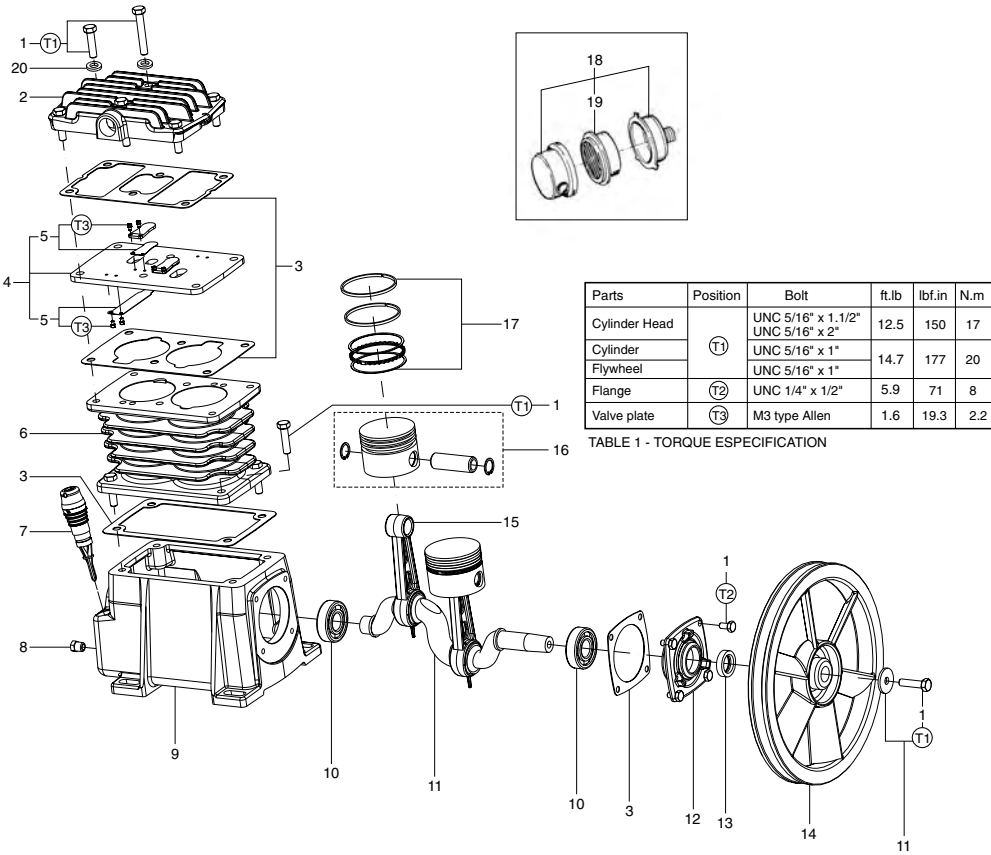

Parts	Position	Bolt	ft.lb	lbf.in	N.m
Cylinder Head		UNC 5/16" x 1.1/2" UNC 5/16" x 2"	12.5	150	17
Cylinder	T1	UNC 5/16" x 1"	14.7	177	20
Flywheel		UNC 5/16" x 1"			
Flange	T2	UNC 1/4" x 1/2"	5.9	71	8
Valve plate	T3	M3 type Allen	1.6	19.3	2.2

TABLE 1 - TORQUE ESPECIFICATION

No.	CODE	DENOMINATION	QTY
1	830.0970-0	Bolt kit	01
2	709.1315-0	Aluminium cylinder head	01
3	830.0971-0/NA	Gasket kit	01
4	809.1012-0	Valve plate	01
5	830.0972-0	Valve plate kit	01
6	709.1259-0	Cylinder	01
7	809.1100-0	Oil level dipstick	01
8	003.0028-4	1/4" plug	01
9	709.1262-0	Crankcase	01
10	019.0002-1	6204 Bearing	02

No.	CODE	DENOMINATION	QTY
11	830.0973-0	Crankshaft	01
12	709.1257-0	Flange	01
13	023.0320-0	Oil seal	01
14	709.1350-0	Flywheel	01
15	709.1261-0	Connecting rod	02
16	016.0116-0	Ø 2.1/2" Piston	02
17	830.0983-0	Ring kit (kit for 1 cylinder)	02
18	007.0156-0	Air filter	01
19	60318003	Filter element	01
20	001.0023-4	5/16" lock washer	06

TECHNICAL DATA 7.580VL30X

MODEL	DISPLACEMENT		MAX PRESSURE		TANK		rpm	Ø PULLEY		BELT SIZE	ELECTRIC MOTOR	DISCHARGE SIZE	OIL CAP		WEIGHT WITH MOTOR		COLOR REF	
	cfm	l/min	psig	bar	Geom	Volume		inches	mm				hp	kW	VOLUME	ml		in qt
7.580VL30X	30	850	175	12	300	80	820	4.0	100	2-A	7.5	5.6	1/2"	1,500	1,580	571	259	Black (pump) Gray (tank)
								4.1	103									

Compressor dimension (inch/mm)
Height 78 7/2,000, length 33 8/860, width 25 2 / 640

AIR COMPRESSOR PARTS

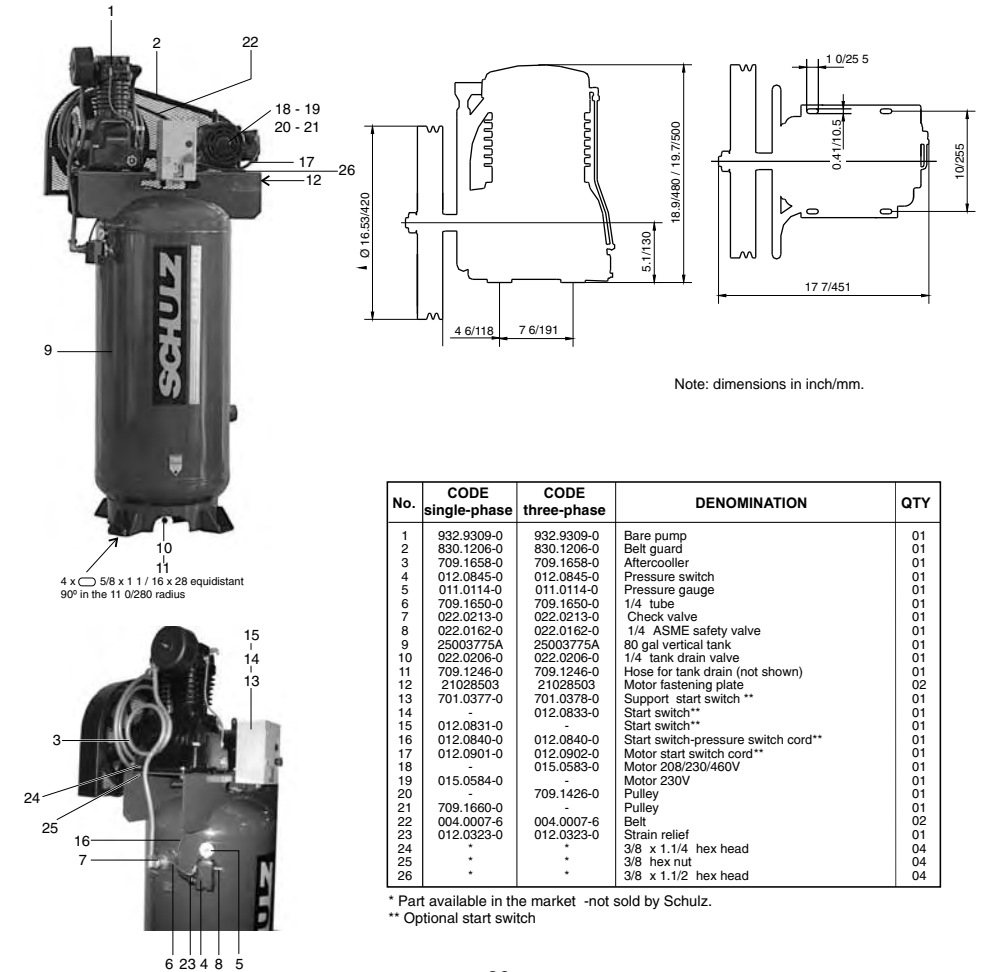

Note: dimensions in inch/mm.

No.	CODE single-phase	CODE three-phase	DENOMINATION	QTY
1	932.9309-0	932.9309-0	Bare pump	01
2	830.1206-0	830.1206-0	Belt guard	01
3	709.1658-0	709.1658-0	Aftercooler	01
4	012.0845-0	012.0845-0	Pressure switch	01
5	011.0114-0	011.0114-0	Pressure gauge	01
6	709.1650-0	709.1650-0	1/4" tube	01
7	022.0213-0	022.0213-0	Check valve	01
8	022.0162-0	022.0162-0	1/4" ASME safety valve	01
9	25003775A	25003775A	80 gal vertical tank	01
10	022.0206-0	022.0206-0	1/4" tank drain valve	01
11	709.1246-0	709.1246-0	Hose for tank drain (not shown)	01
12	21028503	21028503	Motor fastening plate	02
13	701.0377-0	701.0378-0	Support start switch **	01
14	012.0833-0	-	Start switch**	01
15	012.0831-0	-	Start switch**	01
16	012.0840-0	012.0840-0	Start switch-pressure switch cord**	01
17	012.0901-0	012.0902-0	Motor start switch cord**	01
18	-	015.0583-0	Motor 208/230/460V	01
19	015.0584-0	-	Motor 230V	01
20	-	709.1426-0	Pulley	01
21	709.1660-0	-	Pulley	01
22	004.0007-6	004.0007-6	Belt	02
23	012.0323-0	012.0323-0	Strain relief	01
24	-	-	3/8 x 1.1/4" hex head	04
25	-	-	3/8 hex nut	01
26	-	-	3/8 x 1.1/2" hex head	04

* Part available in the market -not sold by Schulz.

** Optional start switch

TECHNICAL DATA 580HV20X

BARE PUMP PARTS

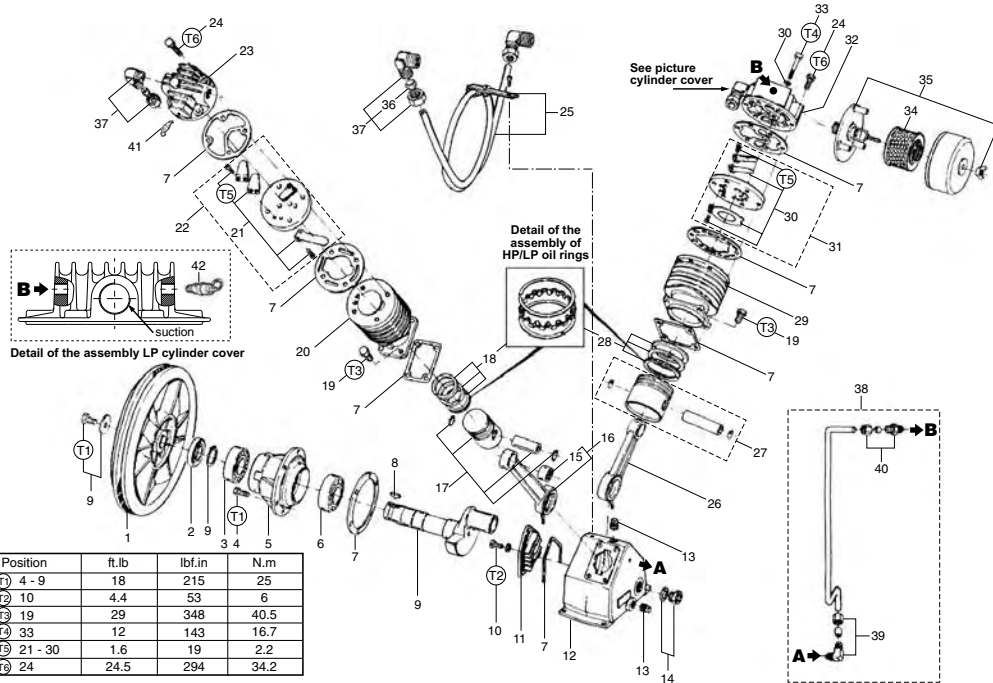

Position	ft.lb	lb.in	N.m
(T1) 4 - 9	18	215	25
(T2) 10	4.4	53	6
(T3) 19	29	348	40.5
(T4) 33	12	143	16.7
(T5) 21 - 30	1.6	19	2.2
(T6) 24	24.5	294	34.2

TABLE 1 - TORQUE SPECIFICATIONS FOR BOLTS

No.	CODE	DENOMINATION	QTY	No.	CODE	DENOMINATION	QTY
1	709.1062-0	Flywheel (1-A)	01	22	830.0785-0	HP 2" valve plate	01
2	023.0265-0	Oil seal	01	23	709.1332-0	HP 2" cylinder cover	01
3	019.0004-8	6206 bearing	01	24	709.1229-0	M8 x 1.25 x 30 hex. head bolt	10
4	019.0005-6	M6 x 1.25 x 20 hex. head screw	06	25	709.1068-0	Intercooler	01
5	709.1056-0	Flange	01	26	016.0042-0	LP connecting rod	01
6	019.0005-6	6207 bearing	01	27	709.1058-0	LP Ø 90mm piston	01
7	830.0776-0/NA	Gasket kit	01	28	830.0780-0	LP 90mm ring kit	01
8	709.0163-3	Key	01	29	830.0779-0	LP 90mm cylinder	01
9	830.0778-0	Crankshaft	01	30	830.0779-0	LP valve plate kit	01
10	20028001	M5 x 0.8 x 20 head bolt	01	31	830.0784-0	LP 90mm valve plate	01
11	709.1231-0	Labyrinth cover	01	32	709.1232-0	LP 90mm cylinder cover	01
12	003.0028-4	Crankcase	01	33	809.1085-0	M6 x 1,0 x 45 Allen hex. head bolt	01
13	030.0028-4	1/4" plug	02	34	007.0118-0	Air filter	01
14	830.0775-0	3/4" oil level sight	01	35	007.0118-0	Filter element	01
15	019.0064-0	Needle bearing	01	36	830.0603-0	5/8" ring kit	01
16	830.0783-0	HP connecting rod with needle bearing	01	37	003.0294-0	NPT 1/2" x 5/8" elbow	02
17	830.0786-0	HP Ø 2" piston	01	38	830.0340-5	Crankcase breather tube kit	01
18	830.0781-0	HP 2" ring kit	01	39	003.0095-5	NPT 1/8"x1/4" elbow	01
19	M10 x 1.5 x 25 hex. head bolt		08	40	003.0054-3	1/8"x1/4" straight connection	01
20	709.1057-0	HP 2" cylinder	01	41	022.0215-0	HP 1/8" ASME safety valve	01
21	830.0782-0	HP valve plate kit	01	42	022.0177-0	LP 1/8" ASME safety valve	01

* Part available in the market - not sold by Schulz.
 Note: HP = high pressure LP = low pressure

TECHNICAL DATA 580VL20X

MODEL	DISPLACEMENT		MAX PRESSURE		TANK		Q1'	Ø PULLEY	BELT SIZE	ELECTRIC MOTOR		D CHARGE SIZE	OIL CAP		WEIGHT WITH MOTOR		COLOR REF	
	cfm	l/min	ps g	bar	Geom	Volume				hp	kw		VOLTAGE [V]	Volume	ml	in qt		lbs
580VL20X	20	566	175	12	300	80	985	4.5	115	1-A	5	3.75	230	1,000	1,060	448	203	

Compressor dimension (inch/mm)
 Height 78/1,980, length 31 5/800, width 25 2 / 640

AIR COMPRESSOR PARTS

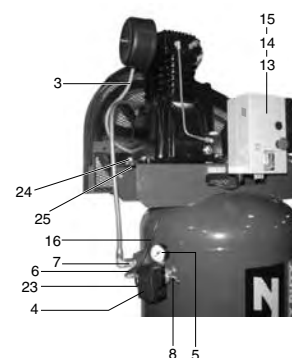
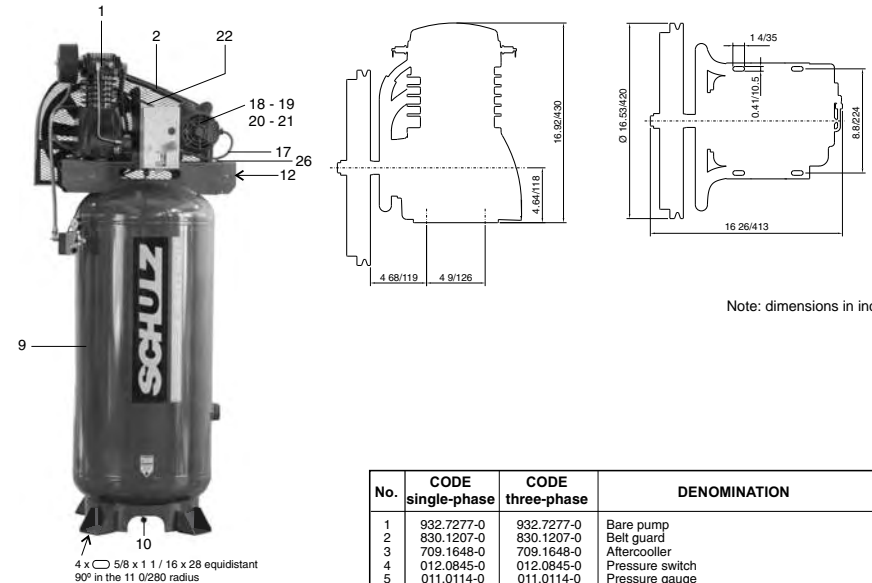

No.	CODE single-phase	CODE three-phase	DENOMINATION	QTY
1	932.7277-0	932.7277-0	Bare pump	01
2	830.1207-0	830.1207-0	Belt guard	01
3	709.1648-0	709.1648-0	Aftercooler	01
4	012.0845-0	012.0845-0	Pressure switch	01
5	011.0114-0	011.0114-0	Pressure gauge	01
6	709.1650-0	709.1650-0	1/4 tube	01
7	60281012	60281012	Check valve	01
8	022.0162-0	022.0162-0	1/4 ASME safety valve	01
9	25003776A	25003776A	80 gal vertical tank	01
10	022.0206-0	022.0206-0	1/4" tank drain valve	01
11	709.1246-0	709.1246-0	Hose for tank drain (not shown)	01
12	21028503	21028503	Motor fastening plate	02
13	701.0378-0	701.0378-0	Support start switch**	01
14	-	012.0832-0	Start switch**	01
15	012.0830-0	-	Start switch**	01
16	012.0840-0	012.0840-0	Start switch-pressure switch cord**	01
17	-	012.0839-0	Motor start switch cord**	01
18	-	015.0581-0	Motor 208/230/460V	01
19	015.0587-0	-	Motor 230V	01
20	-	709.1662-0	Pulley	01
21	709.1659-0	-	Pulley	01
22	004.0127-0	004.0127-0	Belt	01
23	012.0322-0	012.0322-0	Strain relief	01
24	-	-	3/8 x 1 hex head bolt	04
25	-	-	3/8 hex nut	04
26	-	-	3/8 x 7/8 hex head bolt (fix motor)	04

* Part available in the market - not sold by Schulz.
 ** Optional start switch

TECHNICAL DATA 580VL20X

BARE PUMP PARTS

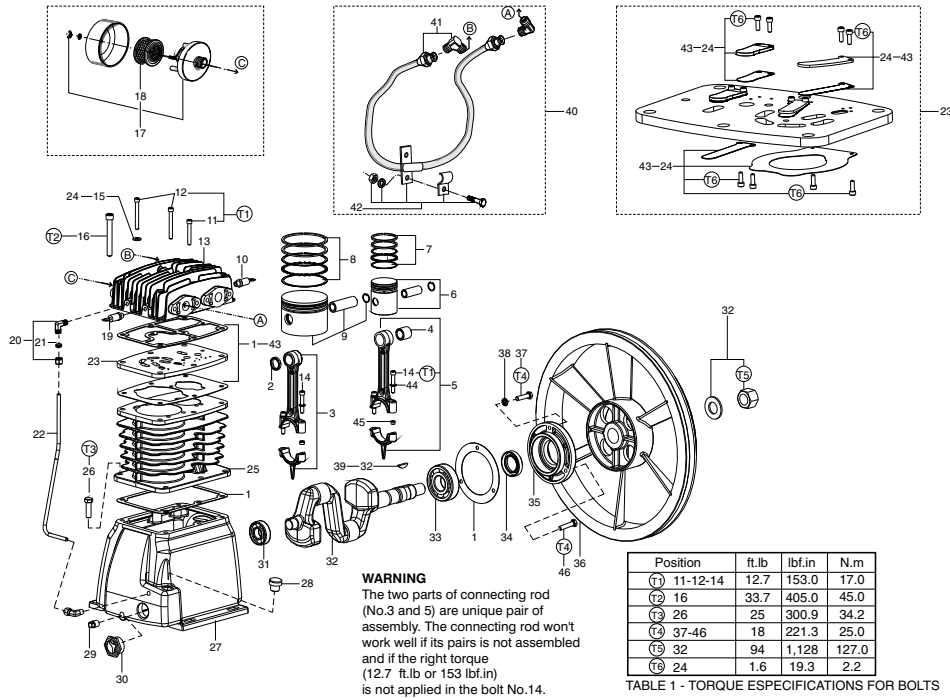

WARNING
The two parts of connecting rod (No.3 and 5) are unique pair of assembly. The connecting rod won't work well if its pairs is not assembled and if the right torque (12.7 ft.lb or 153 lbf.in) is not applied in the bolt No.14.

Position	ft.lb	lbf.in	N.m
(T1) 11-12-14	12.7	153.0	17.0
(T2) 16	33.7	405.0	45.0
(T3) 26	25	300.9	34.2
(T4) 37-46	18	221.3	25.0
(T5) 32	94	1,128	127.0
(T6) 24	1.6	19.3	2.2

TABLE 1 - TORQUE ESPECIFICACIONES FOR BOLTS

No.	CODE	DENOMINATION	QTY	No.	CODE	DENOMINATION	QTY
1	830.1085-0/NA	Gasket kit	01	24	830.1053-0	Valve plate kit	01
2	013.0820-0	Spacer bushing	02	25	709.1569-0	Cylinder	01
3	809.1074-0	LP connecting rod kit	01	26	3/8" x 1" hex. head bolt	06	
4	019.0064-0	Needle bearing	01	27	709.1567-0	Crankcase	01
5	830.1086-0	HP connecting rod with needle bearing kit	01	28	028.0297-0	M18 plug	01
6	830.0786-0	HP Ø 2" piston	01	29	003.0028-4	1/4" plug	01
7	830.0823-0	HP 2" ring kit	01	30	003.0044-6	1" oil level sight	01
8	830.0780-0	LP 90mm ring kit	01	31	019.0002-1	Ø204 bearing	01
9	016.0042-0	LP Ø 90mm piston	01	32	830.1081-0	Crankshaft kit	01
10	022.0189-0	HP 1/8" ASME safety valve	01	33	019.0007-2	Ø306 bearing	01
11	-	1/4" x 1.3/4" Allen hex. head bolt	01	34	023.0338-0	Oil seal	01
12	-	1/4" x 2.1/4" Allen hex. head bolt	01	35	709.1334-0	Flange	01
13	709.1449-0	Aluminum cylinder cover	01	36	709.1062-0	Flywheel	01
14	-	1/4" x 1.1/2" Allen hex. head bolt	04	37	-	5/16" x 1 hex. head bolt	02
15	830.1032-0	Washer copper kit	01	38	-	5/16" lock washer	03
16	-	3/8" x 2" Allen hex. head bolt	06	39	709.0163-3	Key	01
17	809.1085-0	3/4" NPT Air filter	01	40	709.1581-0	Intercooler kit	01
18	007.0118-0	Filter element	01	41	003.0294-0	NPT 1/2" x 5/8" elbow	02
19	022.0177-0	LP 1/8" ASME safety valve	01	42	830.1063-0	Intercooler holder kit	01
20	003.0005-5	NPT 1/8" x 1/4" elbow	02	43	830.1055-0	Gasket/valve plate kit (kit)	01
21	830.0599-8	1/4" ring kit	01	44	-	1/4" Lock washer	04
22	709.1419-0	Crankcase breather tube	01	45	809.1074-C	Guide bushing connecting rod	04
23	809.1059-0	Valve plate	01	46	-	5/16" x 1. 1/4" Hex. head bolt **	01

Note: HP = high pressure LP = low pressure * Part available in the market - not sold by Schulz. ** Assembled of the intercooler holder (item 42).

TECHNICAL DATA 580HV20X

MODEL	DISPLACEMENT		MAX. PRESSURE		TANK		Q1	Ø PULLEY		BELT SIZE	ELECTRIC MOTOR		DISCHARGE SIZE	OIL CAP		WEIGHT WITH MOTOR		COLOR REF
	cfm	l/min	psig	bar	Geom	Volume		gal	rpm		inches	mm		hp	kw	VOLTAGE [V]	Volume	
580HV20X	20	566	175	12	300	80	1050	8.5	216	1-A	5	3.75	1/2"	1,000	1,060	463	210	
								4.8	124					Single phase 230	Three phase 208/230/460			

Compressor dimension (inch/mm)
Height 42 7/1,085, length 55/1,400, width 25 2 / 640

AIR COMPRESSOR PARTS

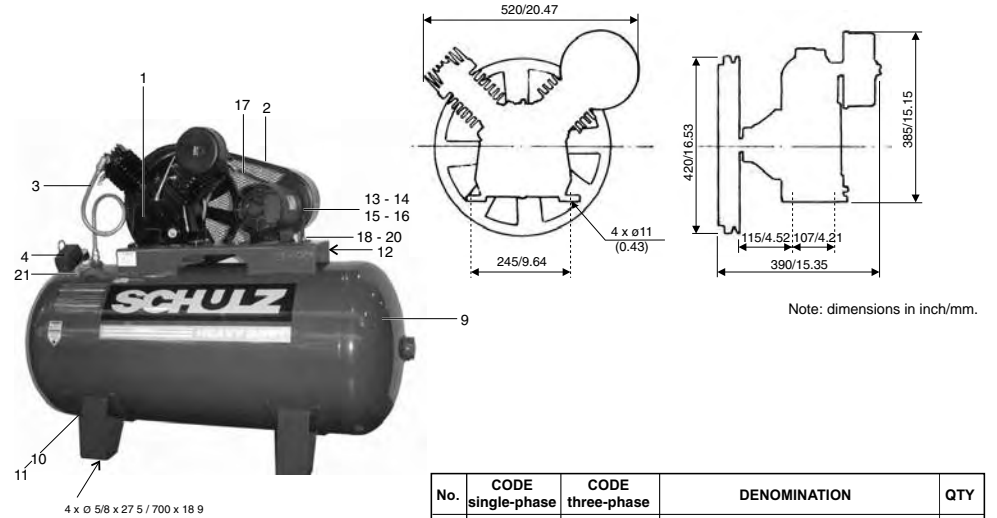

Note: dimensions in inch/mm.

No.	CODE single-phase	CODE three-phase	DENOMINATION	QTY
1	-	-	Bare pump	01
2	830.1223-0	830.1218-0	Belt guard	01
3	709.1116-0	709.1116-0	Aftercooler	01
4	012.0845-0	012.0845-0	Pressure switch	01
5	011.0114-0	011.0114-0	Pressure gauge	01
6	709.1680-0	709.1680-0	1/4 tube	01
7	60281011	60281011	Check valve	01
8	022.0162-0	022.0162-0	1/4 ASME safety valve	01
9	25003938A	25003938A	80 gal horizontal tank	01
10	022.0206-0	022.0206-0	1/4 tank drain valve	01
11	709.1246-0	709.1246-0	Hose for tank drain (not shown)	01
12	21028503	21028503	Motor fastening plate	02
13	-	015.0581-0	Motor 208/230/460V 2P	01
14	015.0587-0	015.0615-0	Motor 230V 4P	01
15	20014041	709.1662-0	Pulley	01
16	709.1659-0	709.1168-0	Pulley	01
17	004.0129-0	004.0127-0	Belt	01
18	-	-	3/8 x 1.1/4 hex head bolt (see note)	08
19	-	-	3/8 hex nut	04
20	-	-	3/8 x 7/8 hex head bolt	04
21	003.0174-4	003.0174-4	1/4 nipple	01

Note: For model with motor three-phase assembled 4 bolts.

* Part available in the market - not sold by Schulz.

TECHNICAL DATA 580VV20X

BARE PUMP PARTS

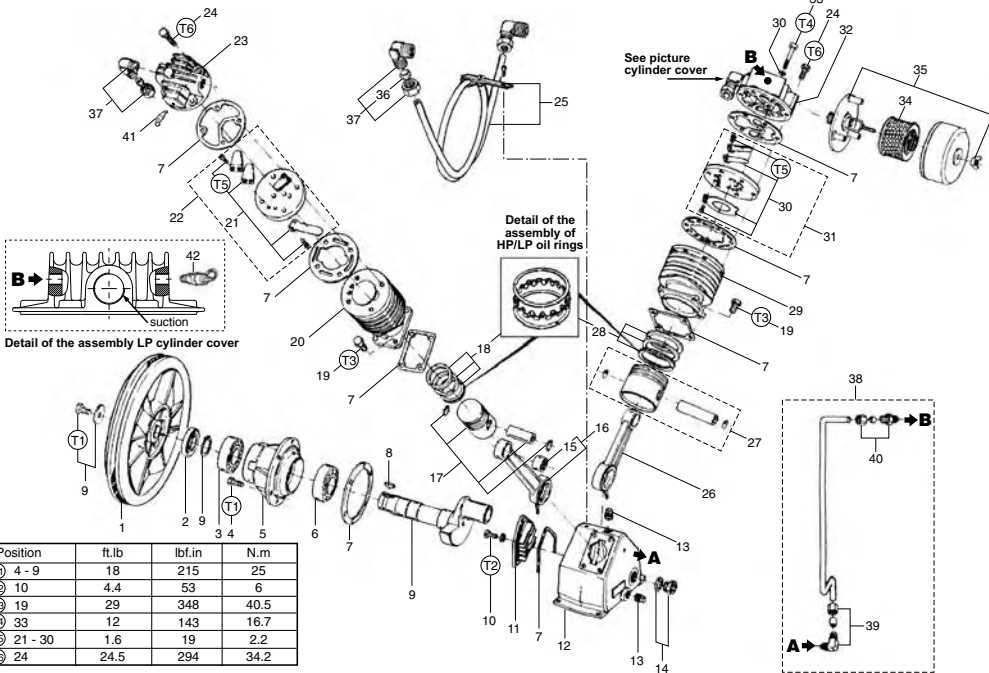

Position	ft.lb	lbf.in	N.m
(T1) 4 - 9	18	215	25
(T2) 10	4.4	53	6
(T3) 19	29	348	40.5
(T4) 33	12	143	16.7
(T5) 21 - 30	1.6	19	2.2
(T6) 24	24.5	294	34.2

TABLE 1 - TORQUE ESPECIFICATIONS FOR BOLTS

No.	CODE	DENOMINATION	QTY	No.	CODE	DENOMINATION	QTY
1	709.1062-0	Flywheel (1-A)	01	22	830.0785-0	HP 2" valve plate	01
2	023.0265-0	Oil seal	01	23	709.1332-0	HP 2" cylinder cover	01
3	019.0004-8	6206 bearing	01	24	M6 x 1.25 x 30 hex. head bolt	01	
4	-	M8 x 1.25 x 20 hex. head screw	06	25	709.1229-0	Intercooler	01
5	709.1056-0	Flange	01	26	709.1068-0	LP connecting rod	01
6	019.0005-6	6207 bearing	01	27	016.0042-0	LP Ø 90mm piston	01
7	830.0776-0/NA	Gasket kit	01	28	830.0780-0	LP 90mm ring kit	01
8	709.0163-3	Key	01	29	709.1058-0	LP 90mm cylinder	01
9	830.0778-0	Crankshaft	01	30	830.0773-0	LP valve plate kit	01
10	20028001	M5 x 0.8 x 20 head bolt	01	31	830.0784-0	LP 90mm valve plate	01
11	709.1231-0	Labyrinth cover	01	32	709.1232-0	LP 90mm cylinder cover	01
12	003.0028-4	Crankcase	01	33	M6 x 1.0 x 45 Allen hex. head bolt	01	
13	830.0775-0	1/4" plug	02	34	809.1085-0	Air filter	01
14	019.0064-0	3/4" oil level sight	01	35	007.0118-0	Filter element	01
15	830.0783-0	Needle bearing	01	36	830.0603-0	5/8" ring kit	01
16	830.0786-0	HP connecting rod with needle bearing	01	37	003.0294-0	NPT 1/2" x 5/8" elbow	02
17	830.0781-0	HP Ø 2" piston	01	38	830.0340-5	Crankcase breather tube kit	01
18	-	HP 2" ring kit	01	39	003.0005-5	NPT 1/8"x1/4" elbow	01
19	-	M10 x 1.5 x 25 hex. head bolt	08	40	003.0054-3	1/8"x1/4" straight connection	01
20	709.1057-0	HP 2" cylinder	01	41	022.0215-0	HP 1/8" ASME safety valve	01
21	830.0782-0	HP valve plate kit	01	42	022.0177-0	LP 1/8" ASME safety valve	01

* Part available in the market - not sold by Schulz.
Note: HP = high pressure LP = low pressure

TECHNICAL DATA 580VL20X - NS

MODEL	DISPLACEMENT		MAX PRESSURE		TANK		Q	Ø PULLEY	BELT SIZE	ELECTRIC MOTOR		DISCHARGE SIZE		OIL CAP		WEIGHT WITH MOTOR		COLOR REF	
	cfm	l/min	psig	bar	Geom	Volume				rpm	2P	2P	hp	kw	VOLTAGE [V]	Volume	ml		in qt
580VL20X-NS	20	566	175	12	300	80	985	4.5	115	1-A	5	3.75	Single phase	230	1,000	1,060	448	203	Black (pump) Gray (tank)

Compressor dimension (inch/mm)
Height 78/1.980, length 31 5/800, width 25 2 / 640

AIR COMPRESSOR PARTS

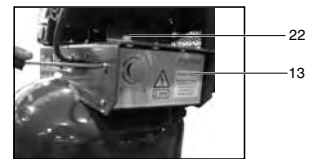
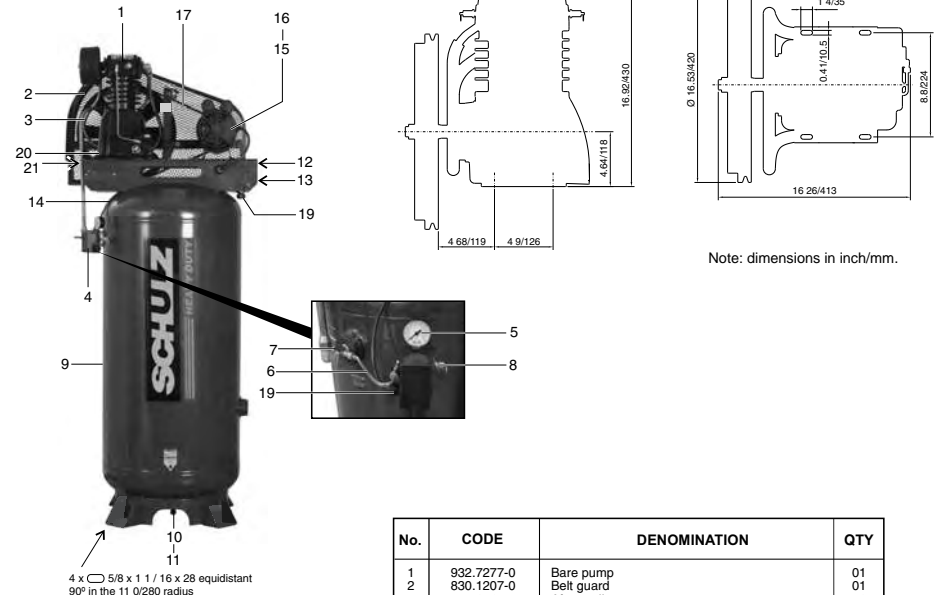

Detail start switch

No.	CODE	DENOMINATION	QTY
1	932.7277-0	Bare pump	01
2	830.1207-0	Belt guard	01
3	709.1648-0	Aftercooler	01
4	012.0845-0	Pressure switch	01
5	011.0114-0	Pressure gauge	01
6	709.1650-0	1/4" tube	01
7	60281012	Check valve	01
8	022.0162-0	1/4 ASME safety valve	01
9	25003776A	80 gal vertical tank	01
10	022.0206-0	1/4 tank drain valve	01
11	709.1246-0	Hose for tank drain (not shown)	01
12	21028503	Motor fastening plate	02
13	012.0936-0	Start switch	01
14	012.0840-0	Start switch-pressure switch cord	01
15	015.0587-0	Motor 230V (single phase)	01
16	709.1659-0	Pulley	01
17	004.0127-0	Belt	01
18	012.0322-0	Strain relief	02
19	012.0723-0	Strain relief	01
20	-	3/8 x 1. hex head bolt	04
21	-	3/8 hex nut	04
22	-	3/8 x 7/8 hex head bolt (fix motor)	04

* Part available in the market - not sold by Schulz.

TECHNICAL DATA 580VL20X - NS

BARE PUMP PARTS

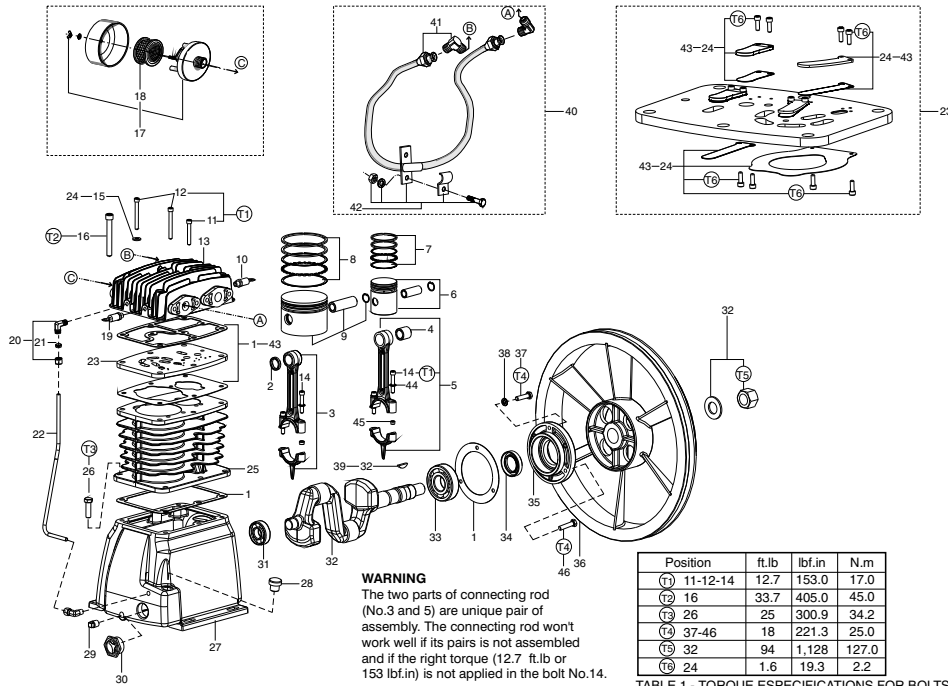

WARNING
The two parts of connecting rod (No.3 and 5) are unique pair of assembly. The connecting rod won't work well if its pairs is not assembled and if the right torque (12.7 ft.lb or 153 lbf.in) is not applied in the bolt No.14.

Position	ft.lb	lbf.in	N.m
(11) 11-12-14	12.7	153.0	17.0
(12) 16	33.7	405.0	45.0
(13) 26	25	300.9	34.2
(14) 37-46	18	221.3	25.0
(15) 32	94	1,128	127.0
(16) 24	1.6	19.3	2.2

TABLE 1 - TORQUE SPECIFICATIONS FOR BOLTS

No.	CODE	DENOMINATION	QTY	No.	CODE	DENOMINATION	QTY
1	830.1088-0/NA	Gasket kit	01	24	830.1053-0	Valve plate kit	01
2	013.0820-0	Spacer bushing	02	25	709.1569-0	Cylinder	01
3	809.1074-0	LP connecting rod kit	01	26	3/8" x 1" hex. head bolt		01
4	019.0064-0	Needle bearing	01	27	709.1567-0	Crankcase	01
5	830.1086-0	HP connecting rod with needle bearing kit	01	28	028.0297-0	M18 plug	01
6	830.0786-0	HP Ø 2" piston	01	29	003.0028-4	1/4" plug	01
7	830.0823-0	HP 2" ring kit	01	30	003.0044-6	1" oil level sight	01
8	830.0780-0	LP 90mm ring kit	01	31	019.0002-1	6204 bearing	01
9	016.0042-0	LP Ø 90mm piston	01	32	830.1081-0	Crankshaft kit	01
10	022.0189-0	HP 1/8" ASME safety valve	01	33	019.0007-2	6306 bearing	01
11	*	1/4" x 1.3/4" Allen hex. head bolt	01	34	023.0338-0	Oil seal	01
12	*	1/4" x 2.1/4" Allen hex. head bolt	01	35	709.1334-0	Flange	01
13	709.1449-0	Aluminum cylinder cover	01	36	709.1062-0	Flywheel	01
14	*	1/4" x 1.1/2" Allen hex. head bolt	04	37	*	5/16" x 1 hex. head bolt	02
15	830.1032-0	Washer copper kit	01	38	*	5/16" lock washer	03
16	*	3/8" x 3" Allen hex. head bolt	06	39	709.0163-3	Key	01
17	809.1085-0	3/4" NPT Air filter	01	40	709.1581-0	Intercooler kit	01
18	007.0118-0	Filter element	01	41	003.0294-0	NPT 1/2" x 5/8" elbow	02
19	022.0177-0	LP 1/8" ASME safety valve	01	42	830.1063-0	Intercooler holder kit	01
20	003.0005-5	NPT 1/8" x 1/4" elbow	02	43	830.1055-0	Gasket/valve plate kit (kit)	01
21	830.0599-8	1/4" ring kit	01	44	*	1/4" Lock washer	04
22	709.1419-0	Crankcase breather tube	01	45	809.1074-C	Guide bushing connecting rod	04
23	809.1059-0	Valve plate	01	46	*	5/16" x 1. 1/4" Hex. head bolt **	01

Note: HP = high pressure LP = low pressure * Part available in the market - not sold by Schulz. ** Assembled of the intercooler holder (item 42).

TECHNICAL DATA 580VV20X

MODEL	DISPLACEMENT		MAX PRESSURE		TANK		Q	Ø PULLEY		BELT SIZE	ELECTRIC MOTOR		DISCHARGE SIZE		OIL CAP		WEIGHT WITH MOTOR		COLOR REF
	cfm	l/min	psig	bar	Geom	Volume		rpm	Inches		mm	hp	kW	VOLTAGE [V]	ml	in qt	lbs	Kg	
580VV20X	20	566	175	12	300	80	1050	8.5	216	1-A	5	3.75	Single phase	1/2"	1,000	1,060	453	205	Black (pump) Gray (tank)
								4.8	124				Three phase						

Compressor dimension (inch/mm)
Height 74 8/1,900, length 31 5/800, width 25 2 / 640

AIR COMPRESSOR PARTS

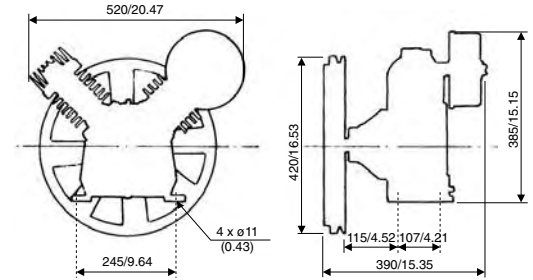
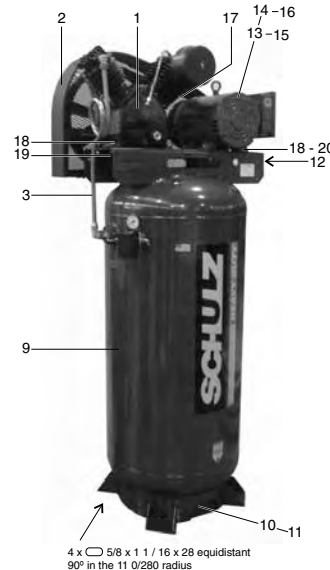

Note: dimensions in inch/mm.

No.	CODE single-phase	CODE three-phase	DENOMINATION	QTY
1	-	-	Bare pump	01
2	830.1223-0	830.1218-0	Belt guard	01
3	709.1647-0	709.1647-0	Aftercooler	01
4	012.0845-0	012.0845-0	Pressure switch	01
5	011.0114-0	011.0114-0	Pressure gauge	01
6	709.1650-0	709.1650-0	1/4 tube	01
7	60281012	60281012	Check valve	01
8	022.0162-0	022.0162-0	1/4 ASME safety valve	01
9	25003776A	25003776A	80 gal vertical tank	01
10	022.0206-0	022.0206-0	1/4" tank drain valve	01
11	709.1246-0	709.1246-0	Hose for tank drain (not shown)	01
12	21028503	21028503	Motor fastening plate	02
13	-	015.0581-0	Motor 208/230/460V 2P	01
14	015.0615-0	-	Motor 230V 4P	01
15	-	709.1662-0	Pulley 4P	01
16	709.1168-0	20014041	Pulley 2P	01
17	004.0129-0	004.0127-0	Belt	01
18	*	*	3/8 x 1.1/4 hex head bolt (see note)	08
19	*	*	3/8 hex nut	04
20	*	*	3/8 x 7/8 hex head bolt	04

Note: For model with motor three-phase assembled 4 bolts.

* Part available in the market - not sold by Schulz.