

APP'L	DATE	LVL	ECN
	10/17/11	A	N01414

VALVE SIZE (NPT)	VALVE MATERIAL	DIMENSIONS			WEIGHT (LBS)	ACTUATOR TORQUE (IN/LBS)	FLOW COEFFICIENT CV
		A	B	C			
1/2"	BRASS	5.58	2.60	7.02	8.16	150*	19
3/4"		5.75	2.93	7.51	8.39	150*	34
1"		6.06	3.56	7.83	8.83	150*	52
1 1/2"		6.58	4.60	9.13	10.65	150*	143
2"		6.94	5.31	9.72	12.96	300	205
2-1/2"		7.33	6.10	10.86	16.14	600	475
3"		7.73	6.89	11.65	21.16	600	780
1/2"	STAINLESS STEEL (316 SS)	5.68	2.80	7.78	8.18	150*	38
3/4"		5.78	3.00	7.93	8.67	150*	71
1"		6.00	3.43	8.43	9.66	150*	110
1 1/2"		6.51	4.46	9.48	11.65	150*	350
2"		6.98	5.40	10.23	14.88	300	600

* ACTUATOR TORQUE FOR THESE UNITS WITH DC VOLTAGE IS 300 IN/LBS.

NOTES:

1. RATED PRESSURE: BRASS 600 PSIG COLD WOG.
SS 900 PSIG COLD WOG
2. VALVES ARE FULL PORT 2 PIECE BALL VALVES
3. AVAILABLE ELECTRICAL: -115VAC-1PH-50/60HZ, MAX CURRENT: 1.7 AMPS
-230VAC-1PH-50/60HZ, MAX CURRENT: 0.9 AMPS
-12VDC, MAX CURRENT: 1.7 AMPS
-24VDC, MAX CURRENT: 0.9 AMPS

(DC VOLTAGE UNITS ARE SUPPLIED WITH POWER CORD BUT WITHOUT PLUG)

4. AVAILABLE CONTROLS: -EXTERNAL MEMBRANE KEYPAD WITH LCD DISPLAY.
-INTERNAL DIPSWITCH CONTROLS FOR TIME CYCLE SETTING (INCLUDES EXTERNAL PUSH-TO-TEST BUTTON WITH POWER LED).

ALSO AVAILABLE: THE ABOVE MENTIONED CONTROLS WITH ALARM RELAY & CONTACTS (CONTACT RATING 10A @ 125VAC)

5. ENCLOSURE RATING: NEMA 1 (LCD VERSION)
NEMA 4 (DIPSWITCH VERSION)
6. AMBIENT TEMPERATURE OPERATING RANGE:
40 TO 120°F (LCD VERSION)
0 TO 120°F (DIPSWITCH VERSION)

7. VALVE INTERNAL MATERIALS:
BRASS VALVES; BALL-CHROME PLATED BRASS
STEM-BRASS, NICKEL PLATED
SEAT-RTFE
316 SS VALVES; BALL-316SS
STEM-316SS
SEATS-PTFE/TFM

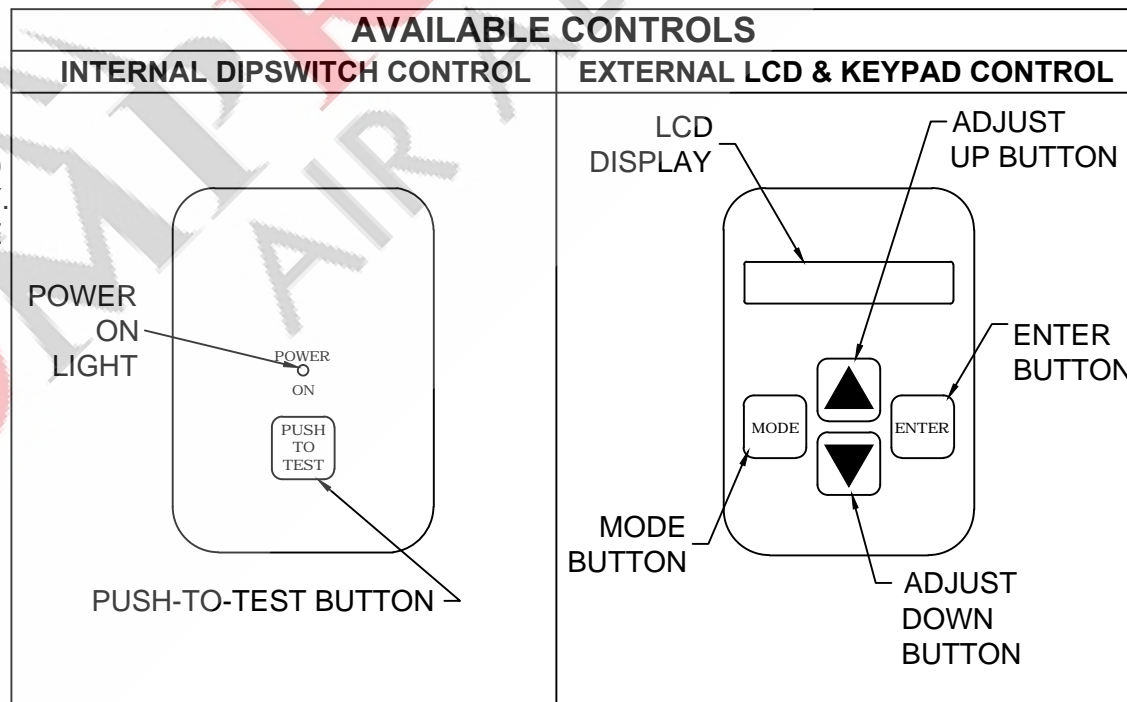
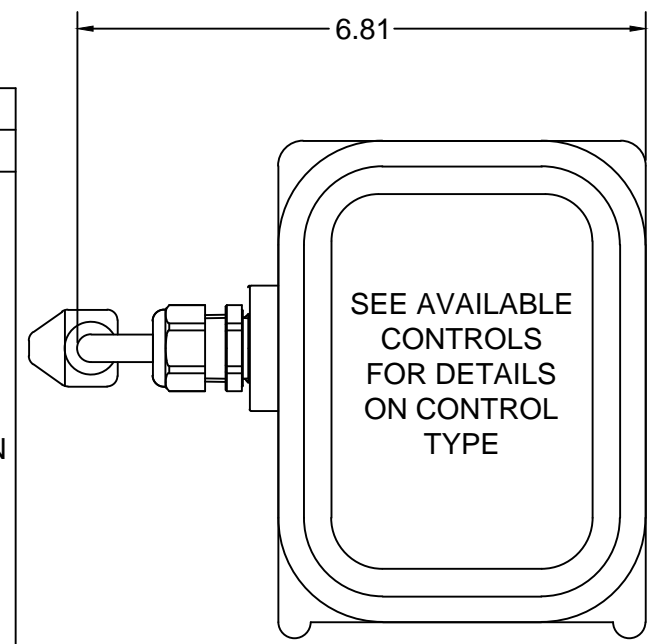
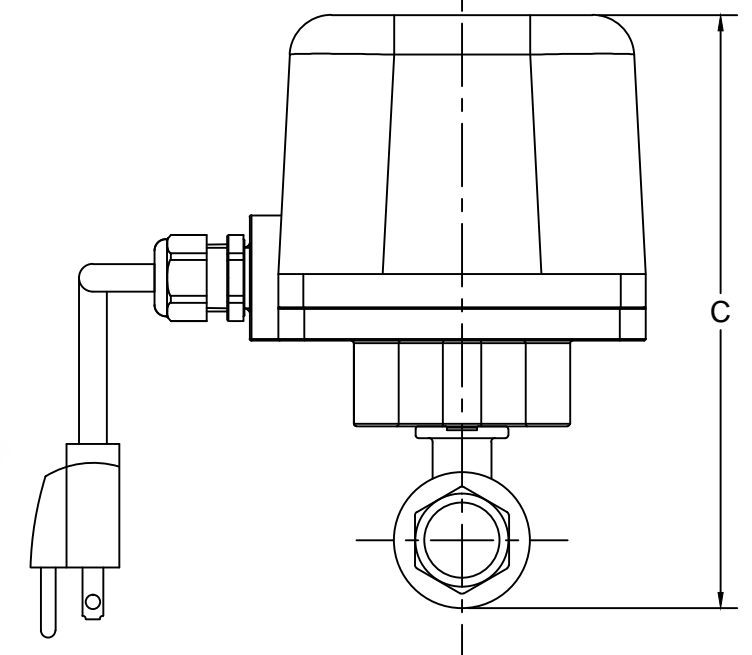
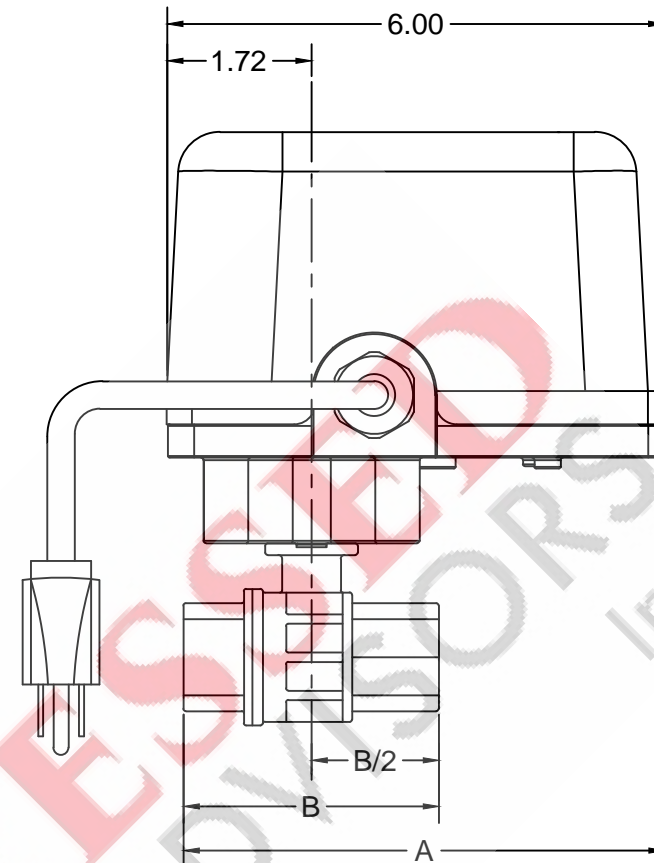

COMPRESSED AIR ADVISORS
Inc.
Compressed Air Advisors, Inc.
Phone: 877.247.2381
info@compressedairadvisors.com
www.compressedairadvisors.com

THIS DRAWING IS THE PROPERTY OF
VAN AIR INC.

AND IS SUBJECT TO RETURN UPON REQUEST. IT SHALL NOT BE COPIED OR DUPLICATED IN ANY MANNER AND SHALL NOT BE SUBMITTED TO OUTSIDE PARTIES FOR EXAMINATION WITHOUT THE CONSENT OF VAN AIR INC. IT SHALL BE USED FOR REFERENCE TO WORK UNDER CONTRACT OR PROPOSALS SUBMITTED BY VAN AIR INC. ONLY.

MOTORIZED DRAIN VALVE
MDV400

DRWN BY: WLN	DATE: 06-11-01	DRWG No. SD-80047	REV A
CHECKED: DK	SCALE: NONE		

APP'L: DK
VAN AIR SYSTEMS
A DIVISION OF VAN AIR INC. LAKE CITY, PA 16423 (814)774-2631 FAX:(814)774-4065