



# INSTALLATION, OPERATION & MAINTENANCE INSTRUCTIONS

## SENTINEL<sup>®</sup> MOTORIZED BALL VALVE WITH ADJUSTABLE CYCLE TIME Model MDV400I

FIGURE 1

NOTES:

1. RATED PRESSURE: BRASS 600 PSIG COLD WOG.  
SS 900 PSIG COLD WOG
2. VALVES ARE FULL PORT 2 PIECE BALL VALVES
3. AVAILABLE ELECTRICAL: -115VAC-1PH-50/60HZ, MAX CURRENT: 1.7 AMPS  
-230VAC-1PH-50/60HZ, MAX CURRENT: 0.9 AMPS  
-12VDC, MAX CURRENT: 1.7 AMPS  
-24VDC, MAX CURRENT: 0.9 AMPS  
(DC VOLTAGE UNITS ARE SUPPLIED WITH POWER CORD BUT WITHOUT PLUG)
4. ENCLOSURE RATING: NEMA 4
5. AMBIENT TEMPERATURE OPERATING RANGE: 0 TO 120°F
6. VALVE INTERNAL MATERIALS:  
BRASS VALVES; BALL-CHROME PLATED BRASS  
STEM-BRASS, NICKEL PLATED  
SEAT-RTFE  
316 SS VALVES; BALL-316SS  
STEM-316SS  
SEATS-PTFE/TFM

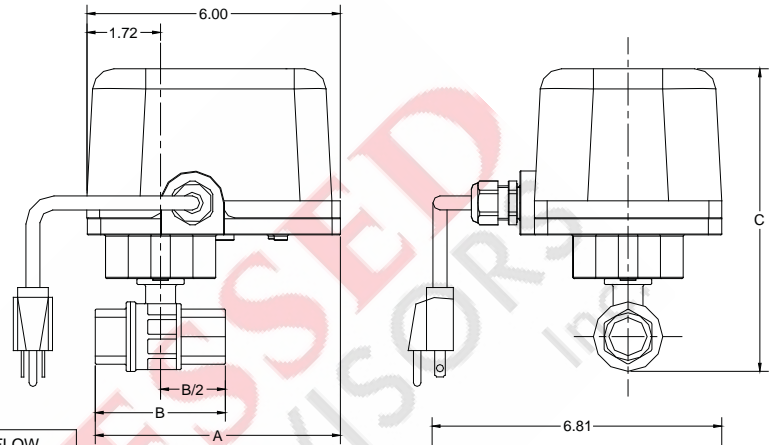

VALVE SIZE (NPT)	VALVE MATERIAL	DIMENSIONS			WEIGHT (LBS)	ACTUATOR TORQUE (IN/LBS)	FLOW COEFFICIENT CV
		A	B	C			
1/2"	BRASS	5.58	2.60	7.02	8.16	150*	19
3/4"		5.75	2.93	7.51	8.39	150*	34
1"		6.06	3.56	7.83	8.83	150*	52
1 1/2"		6.58	4.60	9.13	10.65	150*	143
2"		6.94	5.31	9.72	12.96	300	205
2-1/2"		7.33	6.10	10.86	16.14	600	475
3"		7.73	6.89	11.65	21.16	600	780
1/2"		5.68	2.80	7.78	8.18	150*	38
3/4"	STAINLESS STEEL (316 SS)	5.78	3.00	7.93	8.67	150*	71
1"		6.00	3.43	8.43	9.66	150*	110
1 1/2"		6.51	4.46	9.48	11.65	150*	350
2"		6.98	5.40	10.23	14.88	300	600

\* ACTUATOR TORQUE FOR THESE UNITS WITH DC VOLTAGE IS 300 IN/LBS.

**COMPRESSED AIR ADVISORS**  
Inc.

Compressed Air Advisors, Inc.

Phone: 877.247.2381

info@compressedairadvisors.com

www.compressedairadvisors.com

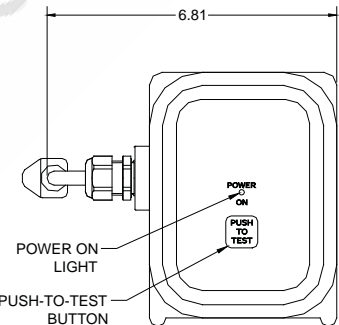

For optimum performance and safety, please read and understand all instructions before installation.

Personnel must use safe working practices and observe all applicable local and international regulations, safety, health and legal requirements when installing and operating this product. Improper operation or maintenance of this product could be potentially dangerous resulting in an accident causing injury or death. Van Air Systems cannot anticipate every possible circumstance which represents a potential hazard. The Warnings in this manual cover the most common potential hazards and are therefore not all-inclusive. The installation and maintenance of this product must be in strict accordance with this instruction manual or the warranty will be invalidated.

### WARNINGS

- DO NOT REMOVE OR REPLACE ANY PART OF THE PRODUCT WHILE IT IS UNDER PRESSURE. SERIOUS PERSONAL INJURY AND/OR DAMAGE TO THE PRODUCT MAY RESULT.
- DO NOT OPERATE THE PRODUCT IF THERE ARE ANY PRESSURE LEAKS. IF A LEAK IS PRESENT, THE PRODUCT MAY BE UNSAFE TO OPERATE. REMOVE THE PRODUCT FROM SERVICE IMMEDIATELY.
- DO NOT OPERATE THIS PRODUCT ABOVE ITS MAXIMUM OPERATING PRESSURE AND/OR TEMPERATURE.
- WHEN INSTALLING THIS PRODUCT, BE SURE TO COMPLY WITH ALL LOCAL, STATE, INTERNATIONAL, AND/OR GOVERNMENT LAWS, RULES, REGULATIONS AND CODES APPLICABLE TO YOUR INSTALLATION.
- DO NOT INSTALL THIS PRODUCT IN A MANNER THAT DISCHARGES TOWARDS PEOPLE OR EQUIPMENT. SERIOUS INJURY AND/OR DAMAGE MAY RESULT.
- PROPER DISPOSAL OF DRAINED LIQUIDS THROUGH THIS PRODUCT ARE THE RESPONSIBILITY OF THE USER.

1.0 DESCRIPTION OF NORMAL OPERATION:

1.1 This product consists of a quarter turn ball valve mated to an electric actuator with a fully adjustable timer controller. The product is designed for mounting in a pipe-line requiring adjustable set closed times and adjustable set open times. A common application is draining fluids from compressed air system components such as separators, filters, airlines and receiver tanks. The timer is set at the factory to open the valve for **10 seconds every 2 hrs.**

2.0 INSTALLATION INSTRUCTIONS: (Reference Figure 2)

- 2.1 Carefully unpack the valve from its shipping box or boxes. Check for visible signs of damage immediately file a claim with the carrier if damage is found. Do not install a damaged valve or actuator. Note: 2" valves and larger will be shipped in two boxes, one containing the valve and one containing the actuator. Smaller valves are shipped with actuator installed.
- 2.2 2" valves and larger will require installing the actuator after installing the valve in the line (See Figure 3).
- 2.3 Make sure that all pressure is removed from the line where the valve is to be installed. Make precautions to ensure the line remains free of pressure during the installation process.
- 2.4 Check the line for obstructions and clean as required.
- 2.5 Make sure all components and parts you are installing meet the temperature and pressure ratings of your system. (piping, manual valves, fittings, or electrical parts are not included)
- 2.6 Install a tee onto the line with the outlet facing down. Install a nipple and manual ball valve on the tee facing down. This is for bypassing the timer valve if it is not operational for any reason.
- 2.7 Install an isolation valve on the remaining opening. Close both manual valves and install a nipple and union on the isolation valve.
- 2.8 Install the valve after the union and install all additional piping downstream of the valve and bypass valve per your local requirements.
- 2.9 Locate a suitable power source and verify it meets the requirements of your valve (see valve label). Wire the valve using the cord included or conduit taking all precautions necessary to meet all required electrical codes for your location. Verify your timer valve is in the closed position and that timing is per your needs.
- 2.10 Review steps 2.1 through 2.9 to verify no steps were skipped.
- 2.11 Slowly pressurize the system. Once the system is fully pressurized, slowly open the isolation valve and check the system for leaks. In the event a leak is discovered, remove pressure from the system and repair before proceeding.
- 2.12 Your valve is now installed and ready for operation.

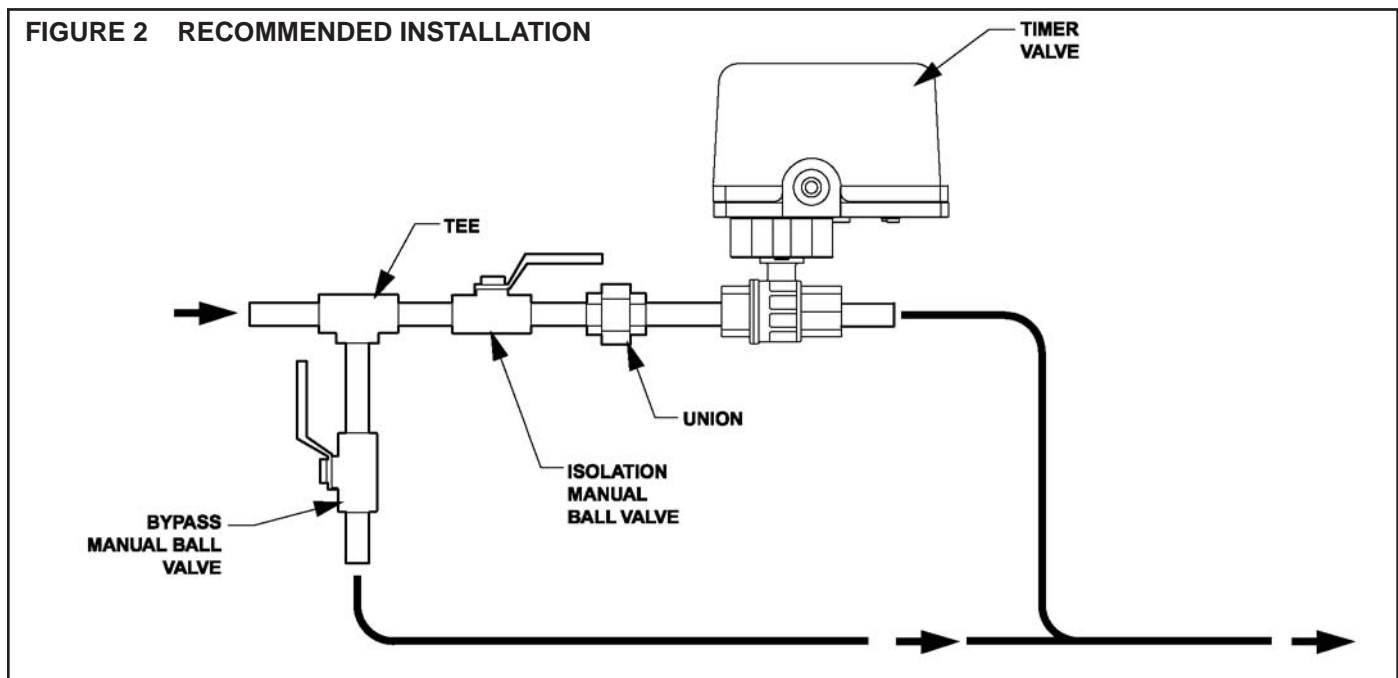

**CAUTION: DO NOT INSTALL MORE THAN ONE FLOW SOURCE PER VALVE. MULTIPLE SOURCES WILL HAVE VARIED PRESSURES RESULTING IN HIGHEST TO LOWEST CONTAMINATION.**

**FIGURE 3 ASSEMBLY OF ACTUATOR AND VALVE (1-1/2" AND LARGER)**

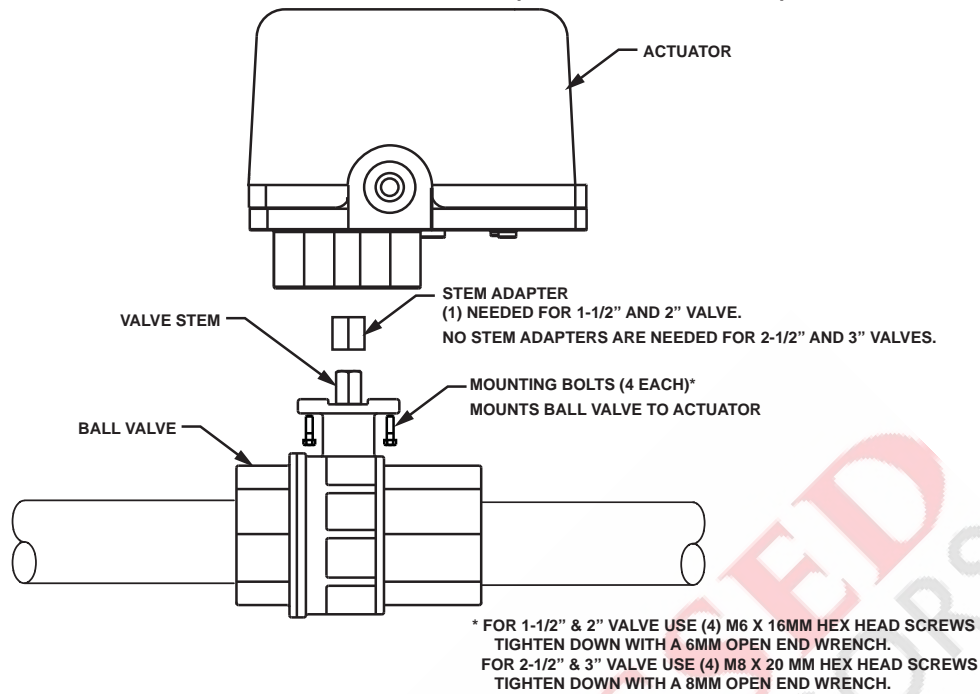

**3.0 ADJUSTING THE TIMER**

- 3.1 The time between drain periods and drain periods are adjusted by a dipswitch keyboard located on the circuit board inside the cover. **Remove power from the unit** and then unscrew the (4) screws holding the cover in place. **Take caution not to stress the wire harness connecting the bottom board to the top board.**
- 3.2 Adjust per the chart in Figure 4. Note: **The timer settings cannot be changed unless power is removed from the unit.**
- 3.3 Reassemble cover making sure that the cover o-ring seal is properly seated and the wire harness is not positioned near the motor.
- 3.4 Apply power to the unit and push the TEST button to clear the previous setting.

**FIGURE 4**

Hrs:Min	Time Between Drain Periods						Drain Periods		
	Switches						Seconds	Switches	
	1	2	3	4	5	6		7	8
0:30	X	X	X	X	X	X	5	X	X
1:00	O	X	X	X	X	X	10	O	X
1:30	X	O	X	X	X	X	15	X	O
2:00	O	O	X	X	X	X	20	O	O
2:30	X	X	O	X	X	X			
3:00	O	X	O	X	X	X			
3:30	X	O	O	X	X	X			
4:00	O	O	O	X	X	X			
4:30	X	X	X	O	X	X			
5:00	O	X	X	O	X	X			
5:30	X	O	X	O	X	X			
6:00	O	O	X	O	X	X			
6:30	X	X	O	O	X	X			
7:00	O	X	O	O	O	X			
7:30	X	O	O	O	X	X			
8:00	O	O	O	O	X	X			
9:00	O	X	X	X	O	X			
10:00	O	O	O	X	X	O			
11:00	O	X	O	X	O	X			
12:00	O	O	O	X	O	X			
13:00	O	X	X	O	O	X			
14:00	O	O	X	O	O	X			
15:00	O	X	O	O	O	X			
16:00	O	O	O	O	O	X			
18:00	O	O	X	X	X	O			
20:00	O	O	O	X	X	O			
22:00	O	O	X	O	X	O			
24:00	O	O	O	O	O	X			
26:00	O	O	X	X	O	O			
28:00	O	O	O	X	O	O			
30:00	O	O	O	X	O	O			

X = Switch On  
O = Switch Off

**DIP SWITCH SETTINGS**

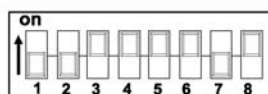
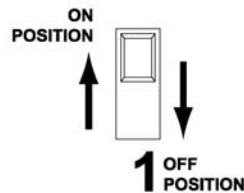

**FACTORY SETTING:**  
10 SECOND OPEN TIME  
2 HOUR CLOSED TIME

**CAUTION**

**POWER MUST BE REMOVED FROM UNIT WHEN CHANGING SETTINGS.**

**TEST BUTTON MUST BE USED ONCE AFTER POWER IS RESTORED TO INITIALIZE NEW SETTINGS.**

4.0 PUSH TO TEST BUTTON

- 4.1 Must be pressed after timer change to initialize new setting.
- 4.2 If depressed and released, the valve will cycle one time.
- 4.3 If depressed and held, the valve will stay open until released.

5.0 REQUIRED MAINTENANCE

Periodically check the valve for the following:

- 5.1 Press the Push to Test button to verify valve rotation. Valve should rotate back to closed position.
- 5.2 Check actuator to valve connection area for debris which could impede proper operation.
- 5.3 Check wires and/or electrical connections for signs of damage.
- 5.4 Check valve for leaks. If leaks are present, remove pressure from the system and replace the ball valve.
- 5.5 Check fasteners for tightness.

**Note: Service work to be done by qualified personnel only! Always remove pressure and power from the unit before servicing.**

<b>TROUBLE SHOOTING</b>		
<b>PROBLEM</b>	<b>CAUSES</b>	<b>SOLUTION</b>
Unit will not operate (Power On LED is not lit)	No power	Check power supply. Check circuit breakers or fuses. Check to see if circuit has a remote power on/off switch.
	Fuse F1 is blown	Replace Fuse F1.
Unit will not operate (Power On LED is lit)	Fuse F2 is blown	Turn power off and back on. Press the Push to Test button. If valve does not rotate, fuse labeled F2 on bottom board is blown. Replace fuse.
	The control board did not sense that the next position, closed or open, was reached for a period of 15 seconds	If the valve rotates several rotations and then randomly stops, press the Push To Test Button. If the valve repeats the fault, the optic sensor has failed (consult factory). If the valve rotates back to closed, the fault was corrected and the unit is running correctly.
	Faulty actuator/motor/valve assembly	Press the Push To Test Button. If the actuator motor turns but the valve does not, check for a broken or loose valve stem. If the stem is broken, replace the valve. If this is not the problem, replace the entire unit. If the motor will not turn after power is applied directly to it, the motor has failed and the unit must be replaced.
Valve binds during rotation	Ball valve seats worn	Replace the ball valve. Ball valve should be replaced at some time between 100,000 and 150,000 cycles (will vary with application).
	Ball valve ball clogged or damaged	Free valve of any debris. If valve is damaged, replace.
Ball valve leaks prematurely	Defective ball valve	Replace ball valve.
Valve position is opposite of where it should be in the sequence	Power Interruption	Press the Push to Test button. Valve will rotate to the closed position.
Valve operates at other than set times	Power interruption during cycle	Valve will continue on set time once power is restored from the point power was interrupted.
	Settings changed with power on	Remove power and adjust timer to desired settings. See SECTION 3.0



Compressed Air Advisors, Inc.

Phone: 877.247.2381

info@compressedairadvisors.com

www.compressedairadvisors.com

