

NOTES:

- 1) MAXIMUM WORKING PRESSURE: 250 PSIG.
- 2) VESSEL IS BUILT TO ASME CODE PLUS CURRENT ADDENDA.
- 3) VESSEL IS STAMPED: "UM" SYMBOL.
- 4) TEMPERATURE RANGE: -20°F TO 300°F (VESSEL RATING).
- 5) APPROXIMATE WEIGHT OF VESSEL: 130 LBS.
- 6) CAPACITY: 19.8 GALLONS.
- 7) VOLUME: 2.7 CUBIC FEET.
- 8) VESSEL INTERIOR IS COATED FOR SUPERIOR CORROSION RESISTANCE. VESSEL EXTERIOR IS COATED WITH ALKYD PRIMER AND WHITE ENAMEL FINISH.

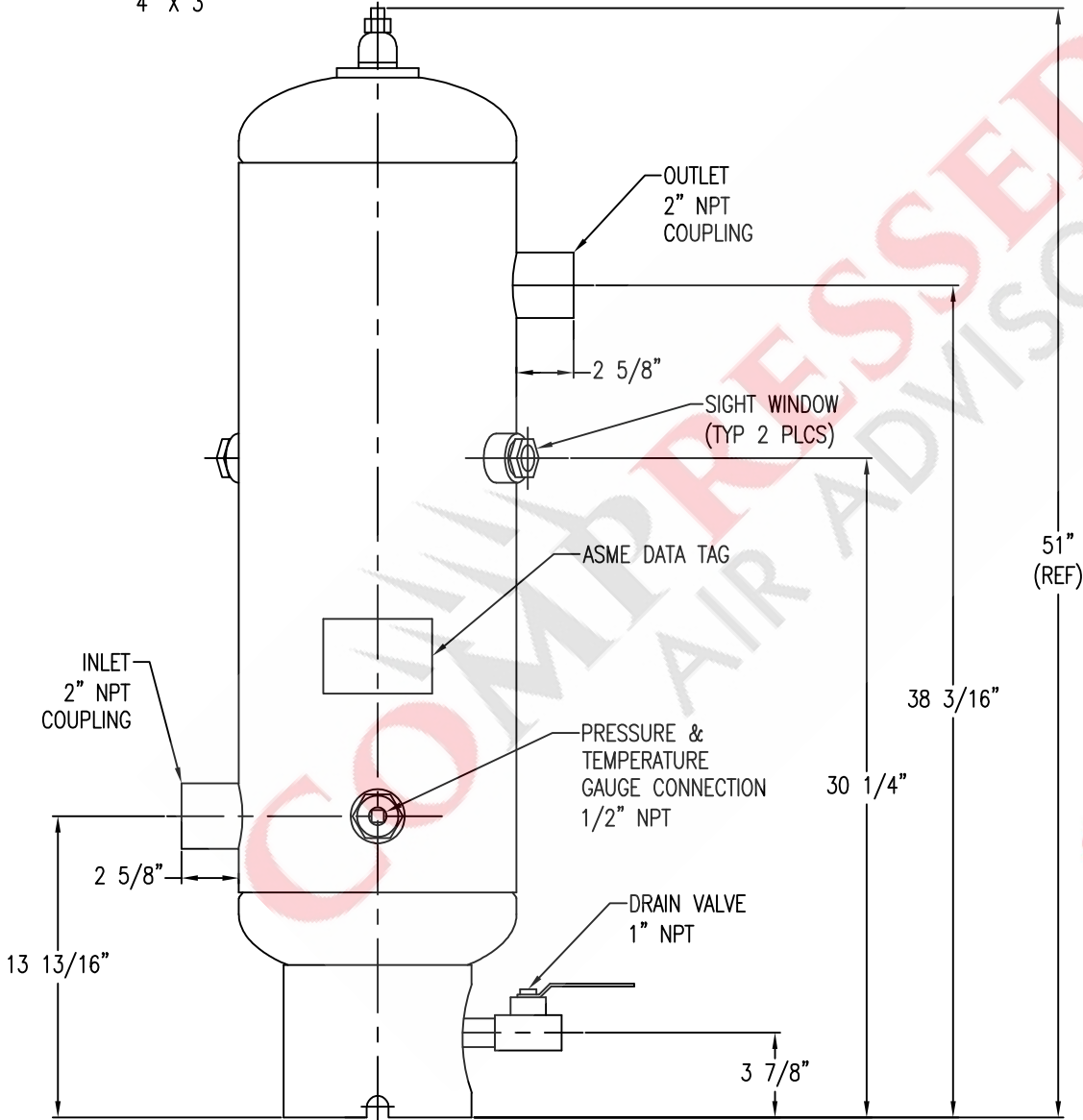

COMPRESSED
AIR ADVISORS
Inc.
Compressed Air Advisors, Inc.
Phone: 877.247.2381
info@compressedairadvisors.com
www.compressedairadvisors.com

This drawing is the property of
VAN AIR SYSTEMS INC

and is subject to return upon request. It shall not be copied or duplicated in any manner and shall not be submitted to outside parties for examination without the consent of Van Air Systems Inc. It shall be used for reference to work under contract or proposals submitted by Van Air Systems Inc. only.

SINGLE TOWER DRYER
D-12

PT #80-1317

| | | | |
|--------------|----------------|-------------------|-----|
| DRWN BY: JMK | DATE: 10-26-00 | DRWG No. SD-13818 | REV |
| CHECKED: | SCALE: NONE | | |

APPL: **VAN AIR SYSTEMS INC**

Lake City, PA 16423 (814)774-2631 Fax: 814/774-3482 Telex: 91-4548