

REVISION HISTORY					
ZONE	REV	DESCRIPTION	DATE	DWN	CHK
	A	RELEASED PER ECN 1052821			
	B	INDICATED OPTIONAL EQUIPMENT: ECN 1065607	1-30-12	KWT	DA

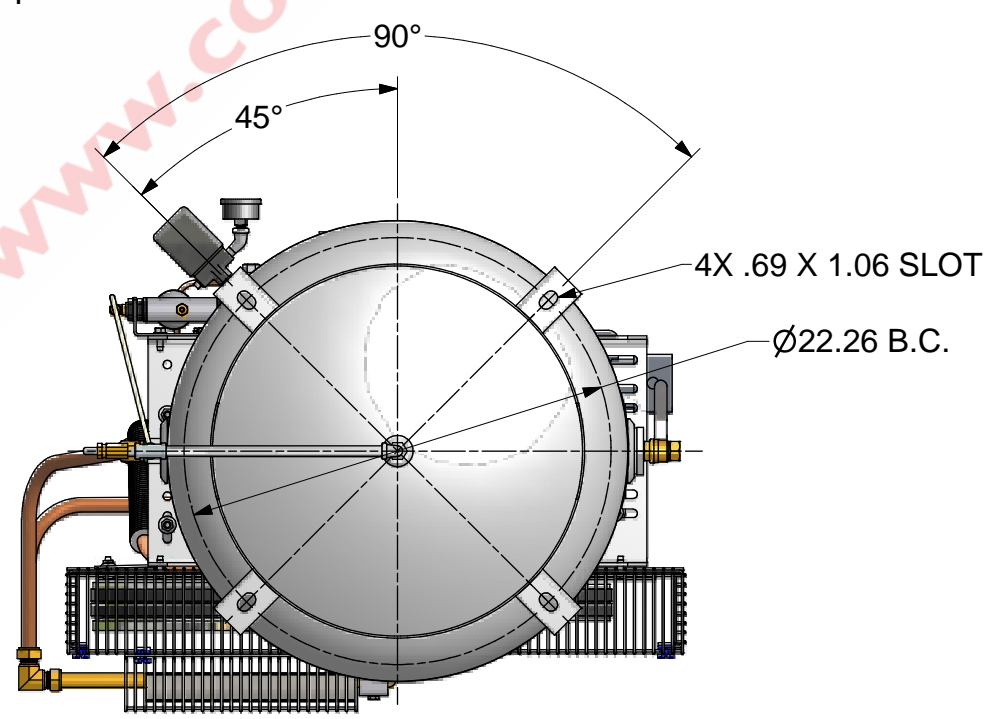
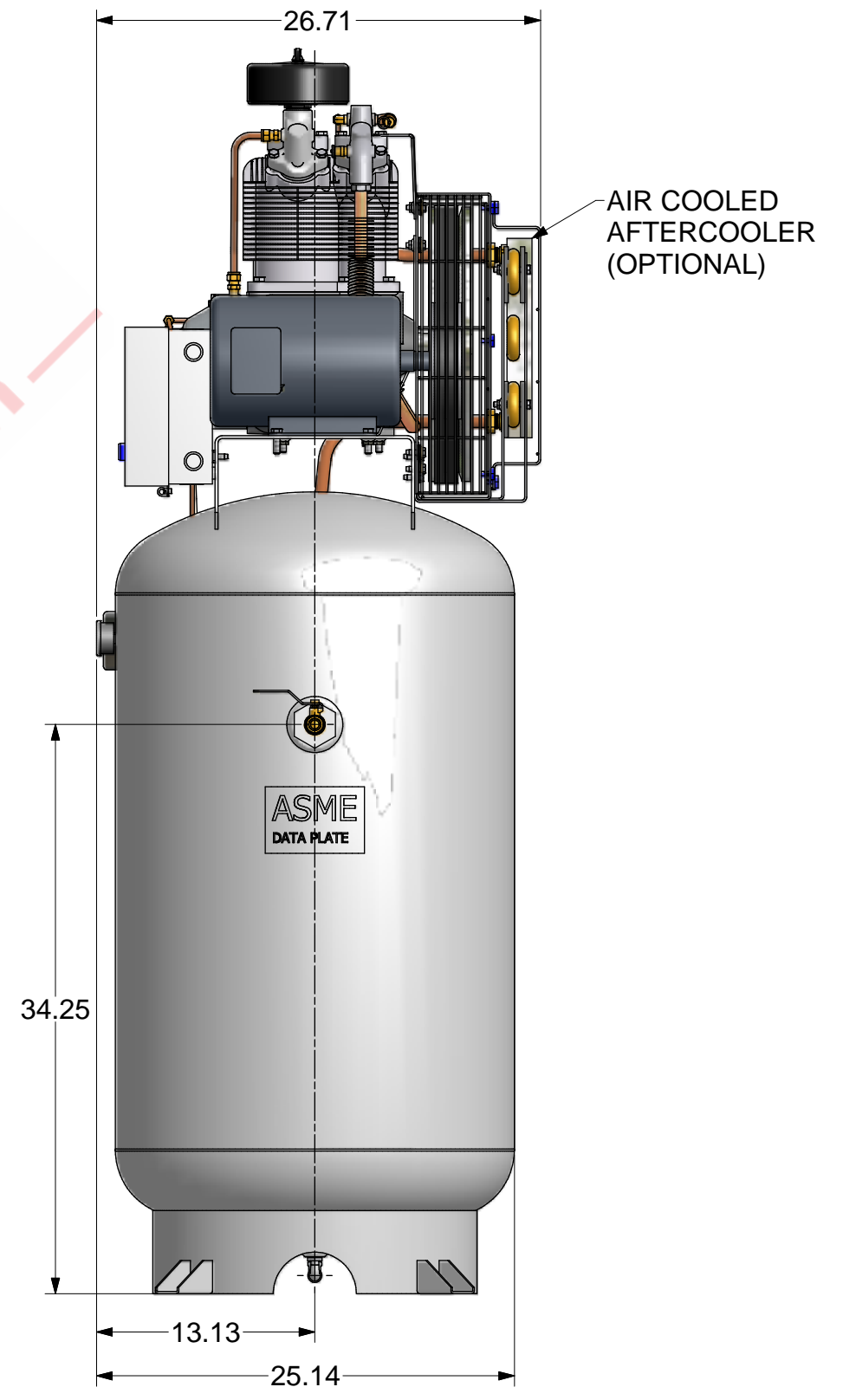
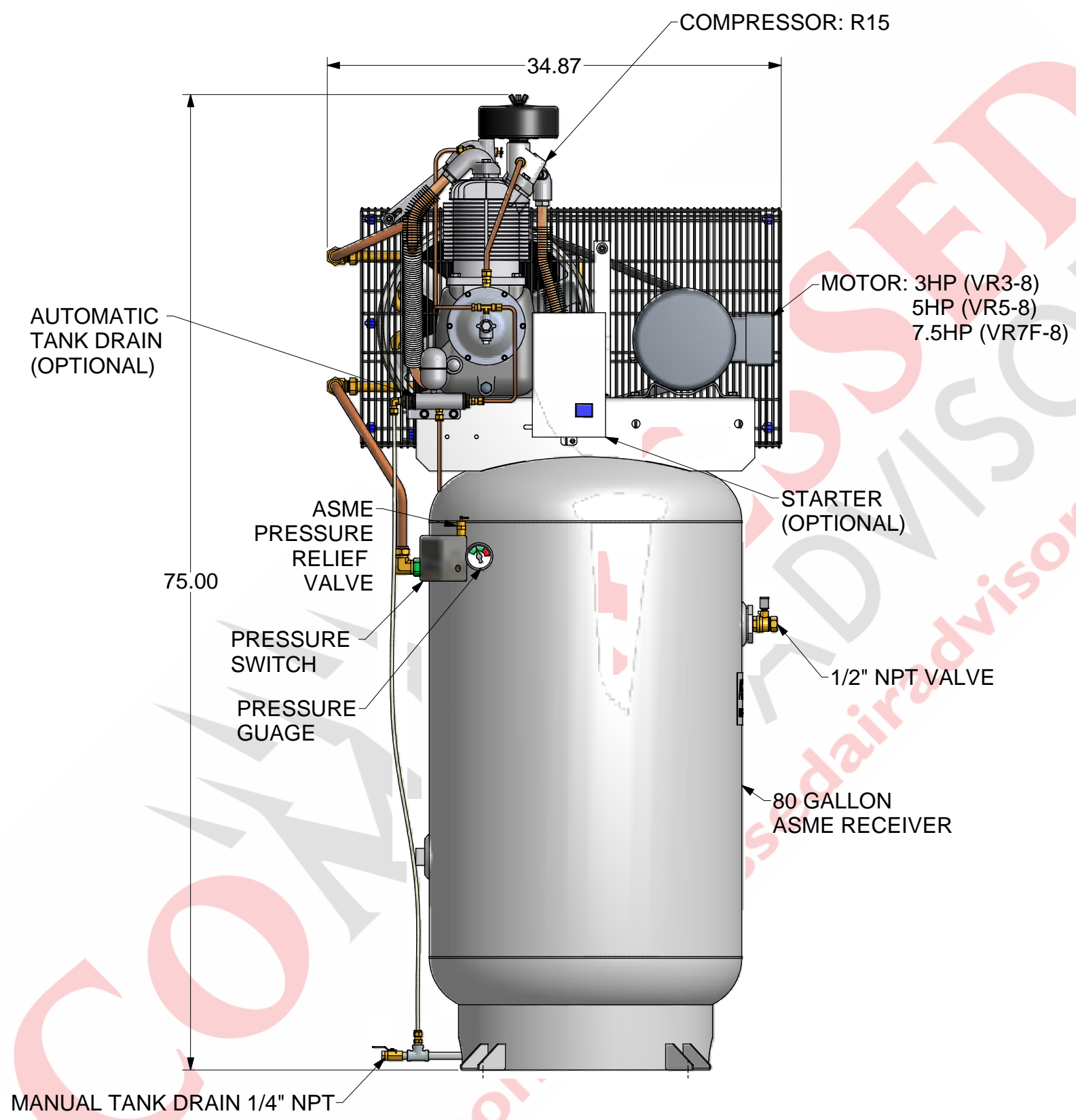
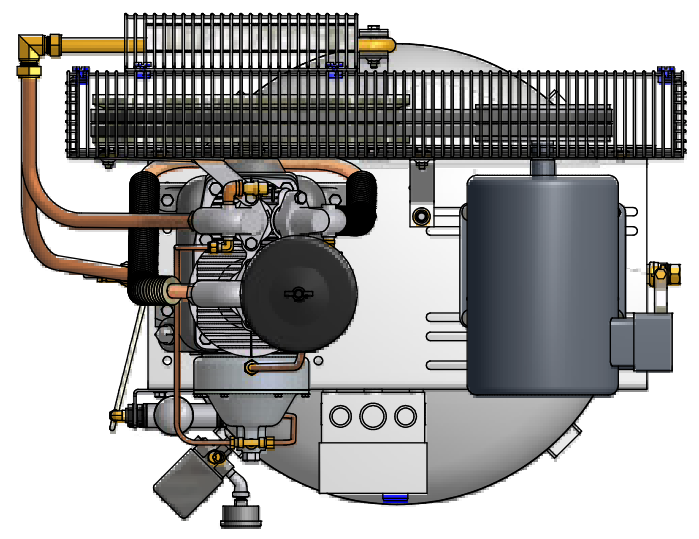
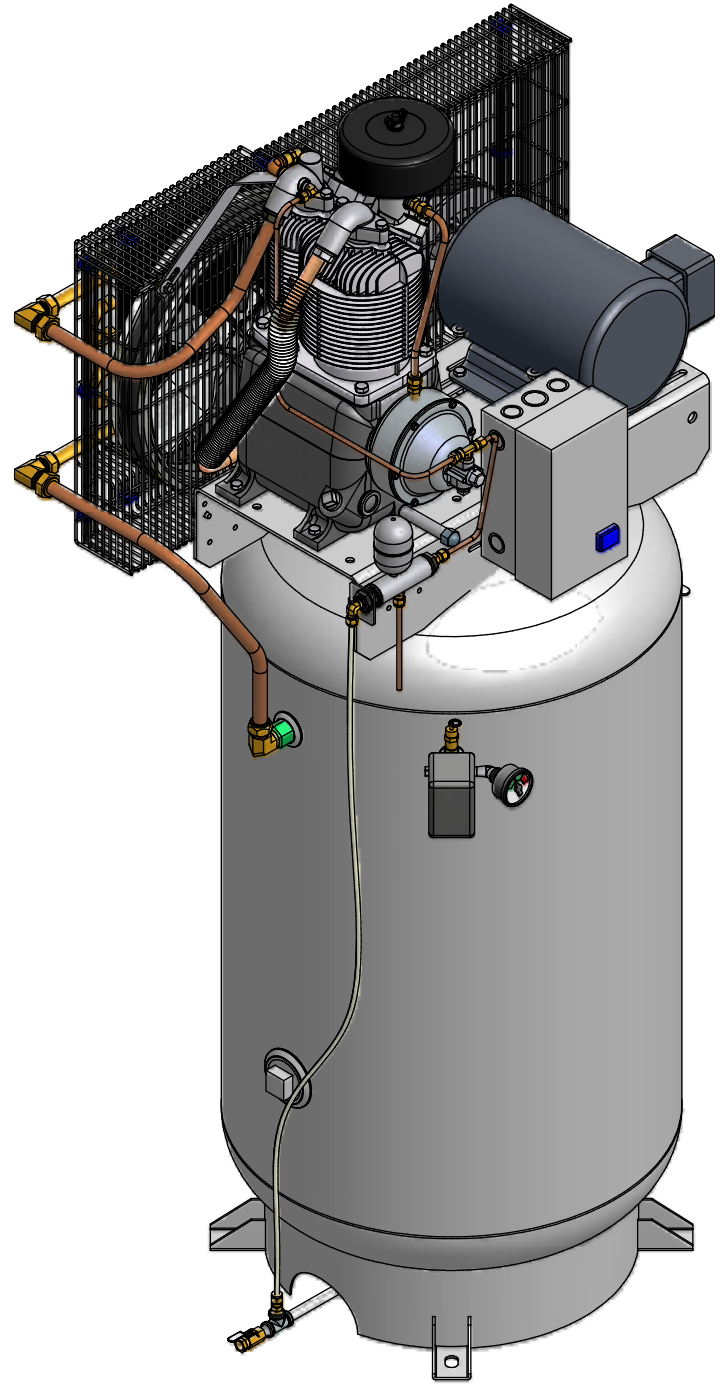

- NOTES:
- DO NOT SCALE DRAWING.
 - SPECIFICATIONS AND DIMENSIONS ARE SUBJECT TO CHANGE WITHOUT NOTICE OR OBLIGATION.
 - ALL DIMENSIONS IN INCHES.
 - ADD 1.00" TO HIEGHT FOR VIBRATION OPTION.

COMPRESSED
AIR ADVISORS
Inc.
Compressed Air Advisors, Inc.
Phone: 877.247.2381
info@compressedairadvisors.com
www.compressedairadvisors.com

FINISH OF CHAMFERS AND FILLETS TO CONFORM TO ROUGHEST ADJACENT AREA. SURFACE ROUGHNESS MAXIMUM PER ASME B46.1. FULL THREAD DEPTHS ARE MINIMUM.		CONFIDENTIAL - THE INFORMATION CONTAINED IN THIS DOCUMENT IS THE PROPERTY OF GARDNER DENVER, INC. IT IS NOT FOR PUBLIC DISCLOSURE. POSSESSION OF THE INFORMATION DOES NOT CONVEY ANY RIGHT TO LOAN, SELL OR DISCLOSE THE INFORMATION. UNAUTHORIZED REPRODUCTION OR USE OF THE INFORMATION IS PROHIBITED. THIS DOCUMENT IS TO BE RETURNED TO GARDNER DENVER, INC. UPON THE COMPLETION OF THE PURPOSE FOR WHICH IT IS LOANED OR UPON REQUEST.	
UNLESS OTHERWISE SPECIFIED DIMENSIONS ARE IN INCHES		DIMENSIONING AND TOLERANCING PER ASME Y14.5-2009	
TOL. ON DECIMALS: .X = ± .05 TOL. ON DECIMALS: .XX = ± .02 TOL. ON DECIMALS: .XXX = ± AS SPECIFIED TOL. ON ANGLES: ± 0'-30'		THREADS PER ASME B1.1 GAGING SYSTEM 21 U.O.S., ANSI B1.20.1 & B1.20.3	
THIRD ANGLE PROJECTION		HEAT TREATMENT	ENG. REF: A
Gardner Denver Inc. Quincy, IL		TITLE: OUTLINE-BARE UNIT	
DWN BY: KWT 7/2/2010		VR3-8, VR5-8, VR7F-8	BY: B
CKD BY: DA 7/2/2010		313CAS800	SCALE: 1/5