

**CHAMPION**

**R-SERIES**

Air Compressors & Units

## R-30 PARTS LIST MANUAL

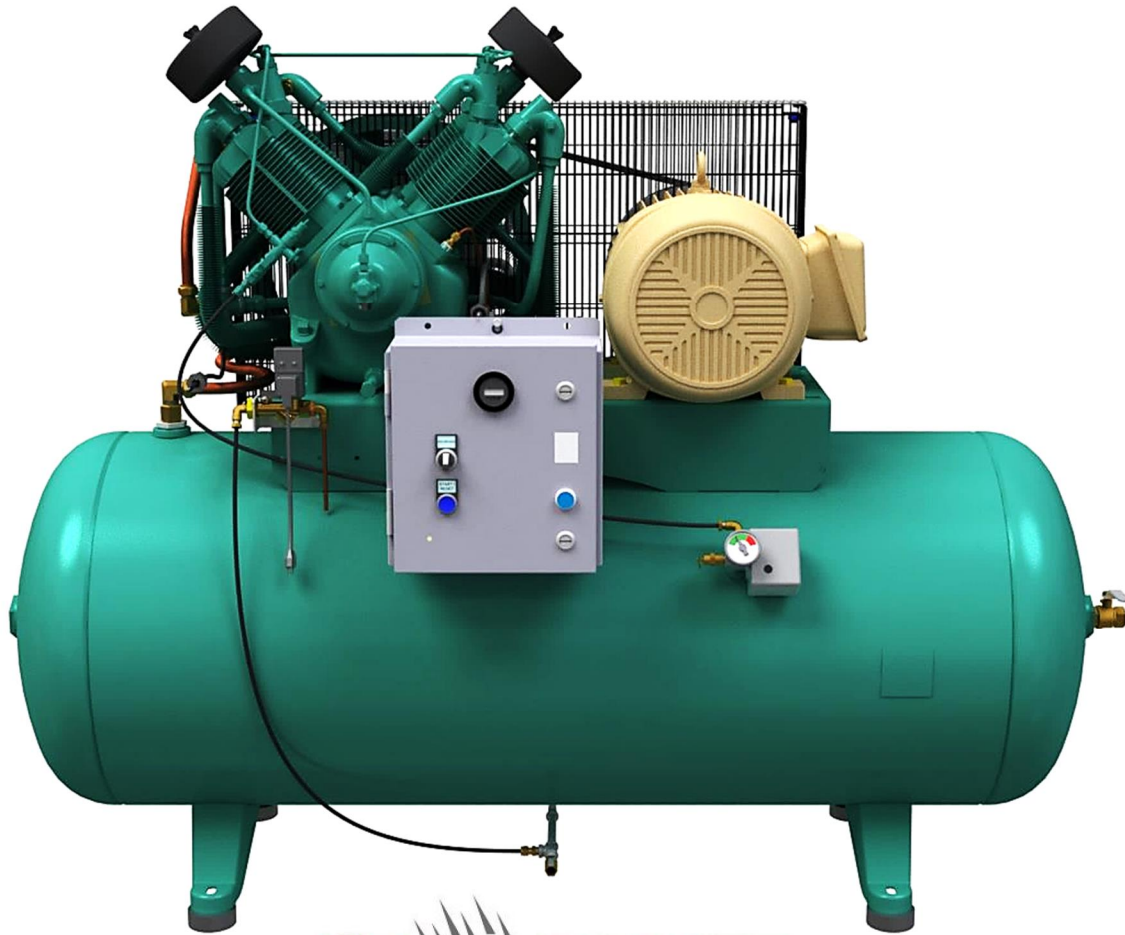

**COMPRESSED**  
AIR ADVISORS  
Inc.

Compressed Air Advisors, Inc.

Phone: 877.247.2381

[info@compressedairadvisors.com](mailto:info@compressedairadvisors.com)

[www.compressedairadvisors.com](http://www.compressedairadvisors.com)



REFER TO THE R-SERIES OPERATION & SERVICE MANUAL FOR IMPORTANT SAFETY INFORMATION. READ, UNDERSTAND AND RETAIN ALL INSTRUCTIONS BEFORE OPERATING OR SERVICING THIS EQUIPMENT TO PREVENT INJURY OR EQUIPMENT DAMAGE.

## **MAINTAIN COMPRESSOR RELIABILITY AND PERFORMANCE WITH GENUINE CHAMPION® COMPRESSOR PARTS AND SUPPORT SERVICES**

Champion® Compressor genuine parts, manufactured to design tolerances, are developed for optimum dependability . specifically for Champion compressor systems. Design and material innovations are the result of years of experience with hundreds of different compressor applications. Reliability in materials and quality assurance are incorporated in our genuine replacement parts.

Your authorized Champion Compressor distributor offers all the backup you need. A worldwide network of authorized distributors provides the finest product support in the air compressor industry.

Your authorized distributor can support your Champion air compressor with these services:

1. Trained parts specialists to assist you in selecting the correct replacement parts.
2. A full line of factory tested CHAMPLUBi compressor lubricants specifically formulated for use in Champion compressors.
3. Repair and maintenance kits designed with the necessary parts to simplify servicing your compressor.

Authorized distributor service technicians are factory trained and skilled in compressor maintenance and repair. They are ready to respond and assist you by providing fast, expert maintenance and repair services.

**COMPRESSED**  
AIR ADVISORS  
Inc.

**Compressed Air Advisors, Inc.**

Phone: 877.247.2381

[info@compressedairadvisors.com](mailto:info@compressedairadvisors.com)

[www.compressedairadvisors.com](http://www.compressedairadvisors.com)

When ordering parts, specify Compressor MODEL, HORSEPOWER and SERIAL NUMBER (see nameplate on unit). All orders for Parts should be placed with the nearest authorized distributor.

Order by part number and description. Reference numbers are for your convenience only.

# Table of Contents

Section 1 – General .....	5
Dimensions.....	5
Specifications .....	5
Performance.....	5
Section 2 – Compressor .....	6
Crankcase Group .....	6
Crankshaft Group .....	7
Centrifugal Unloader Group.....	8
Piston/Rod Group – Low Pressure.....	10
Piston/Rod Group – High Pressure.....	12
Cylinder Group – Standard.....	14
Cylinder Group – with Head Unloaders (optional).....	16
Tubing and Control Group – Standard.....	18
Tubing and Control Group – with Head Unloaders (optional).....	20
Tubing and Control Group – Engine Driven .....	22
High Temperature Switch (optional) .....	24
Low Oil Shutdown Control (optional) .....	25
Section 3 – Electric Packages .....	26
Vertical Package .....	26
Horizontal Package – Simplex .....	28
Electric Motor List .....	30
Tank Drain – Manual.....	31
Tank Drain – Electric (optional).....	32
Control Group – Start/Stop.....	32
Control Group – Dual Control (optional) .....	34

# Table of Contents

Power Transmission.....	35
Belt Guard – Standard .....	36
Belt Guard – with Aftercooler (optional) .....	37
Discharge Piping – Vertical, Standard.....	38
Discharge Piping – Vertical, with Aftercooler (optional) .....	39
Discharge Piping – Horizontal, Standard.....	40
Discharge Piping – Horizontal, with Aftercooler (optional) .....	41
Notes .....	42

**COMPRESSED**  
AIR ADVISORS  
Inc.

## Section 1 – General

### Dimensions

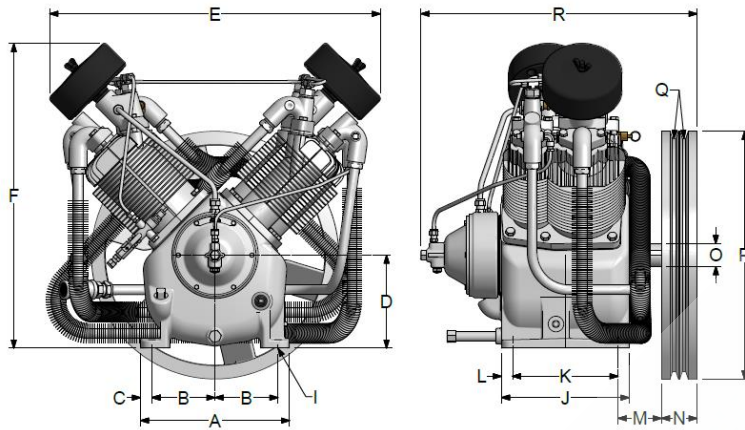

C407-C  
Ref Drawing

Item		R10D
A	Base-Width	11-1/8"
B	Bolt Down-Width	4-13/16"
C	Bolt Down to Edge	3/4"
D	Base to Crank Ctr	7"
E	Overall Width	24"
F	Overall Height	23-9/16"
I	Bolt Down Hole Dia.	17/32"
J	Base-Depth	9-3/4"
K	Bolt Down Depth	8-1/16"
L	Bolt Down to Edge	27/32"
M	Bolt Hole to Wheel (Max.)	3-1/16"
N	Flywheel Width	2-23/32"
O	Crank Diameter	1-3/4"
P	Flywheel Diameter	18-7/8"
Q	Flywheel Grooves	2VB
R	Overall Depth	21-1/8"

- H.P. Exhaust Opening: 3/4" tubing
- Flywheel Rotation – Clockwise when viewed from front, flywheel to rear.

### Specifications

BORE & STROKE (INCHES)	NO. OF CYLINDERS	OIL CAPACITY (QTS.)	WEIGHT (LBS)	PRESSURE (PSIG)	CU FT./REV.	MIN./MAX. RPM
4-5/8 & 2-1/2 x 3	4	4	220	175	.0583	400/1050

### Performance

OUTPUT PRESS. PSIG	MOTOR H.P.	PUMP RPM	DISPL. CFM	COOLING AIR FLOW CFM	HEAT REJECTION BTU/HR	APPROX. PULLEY O.D. INCHES
125	7.5	646	37.7	937	16,800	7.00
175	7.5	568	33.1	824	16,800	6.20
125	10	777	45.3	1127	22,400	8.35
175	10	758	44.2	1099	22,400	8.15
125	15	1049	61.2	1521	33,600	11.15
175	15	1049	61.2	1521	33,600	11.15

All data is based on 1800 RPM electric motors as a power source.

Pulley Dia. (approx.) =  $\frac{\text{Compressor RPM} \times \text{Flywheel Dia.}}{\text{Motor or Engine RPM}}$

## Section 2 – Compressor

### Crankcase Group

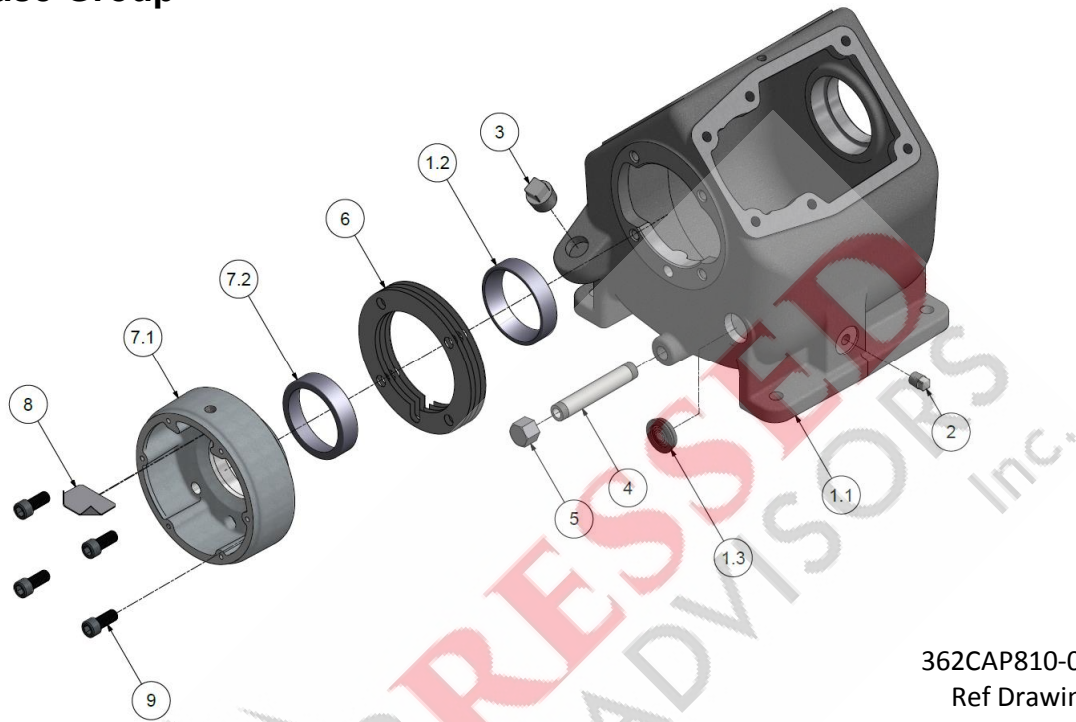

362CAP810-01  
Ref Drawing

#### CRANKCASE GROUP

302CAP013

1.1	M1898	CRANKCASE	1
1.2	NR2016*	MAIN BEARING, CUP	1
1.3	RE714	OIL LEVEL GAUGE	1
2	64AA5	PLUG	1
3	64A5	PLUG	1
4	M492	NIPPLE	1
5	M461	CAP	1
6	SE3030*	GASKET, 0.032	1
6	SE3030A*	GASKET, 0.005	1
6	SE3030B*	GASKET, 0.010	1
6	SE3030C*	GASKET, 0.015	1
7.1	P12273C	GOVERNOR HOUSING	1
7.2	NR2016*	MAIN BEARING, CUP	1
8	P12381A	PLATE, GOVERNOR BAFFLE	1
9	M3690	SCREW (torque @ 550 in-lbs)	4

\*not sold separately – see repair parts

#### REPAIR PARTS

1.2,7.2	Z8981	MAIN BEARING	2
6	Z3030	GOVERNOR HOUSING GASKET SET	1
-	Z10887	COMPRESSOR GASKET SET (excludes valve gaskets)	1

## Crankshaft Group

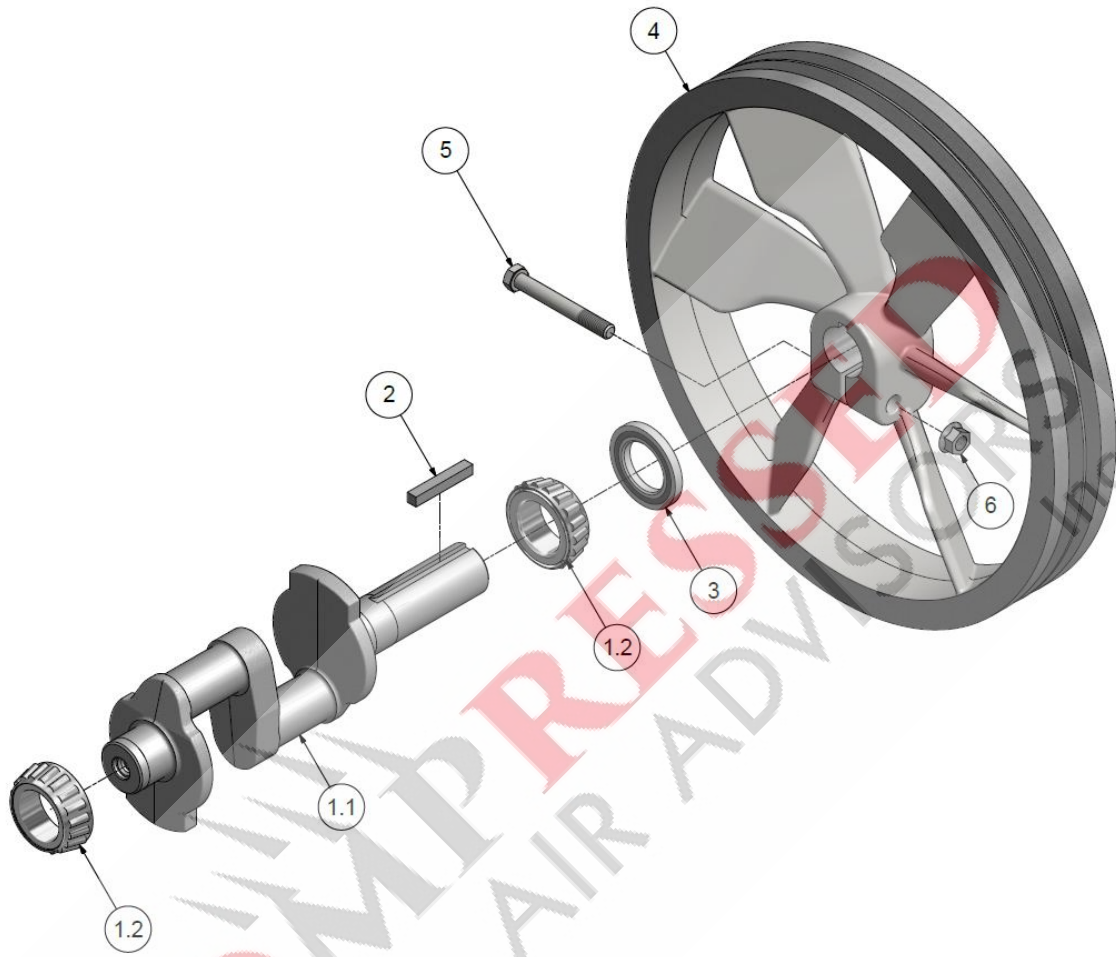

363CAP810-01  
Ref Drawing

### CRANKSHAFT GROUP

302CAP004

1.1	P12414B	CRANKSHAFT	1
1.2	P12413A*	MAIN BEARING, CONE & ROLLER	2
2	RE208	KEY	1
3	OSN36A	OIL SEAL	1
4	NR367B	FLYWHEEL	1
5	655EE160	SCREW (torque @ 600 in-lbs)	1
6	M2955	NUT	1

\*not sold separately – see repair parts

### REPAIR PARTS

1.2	Z8981	MAIN BEARING	2
-----	-------	--------------	---

# Centrifugal Unloader Group

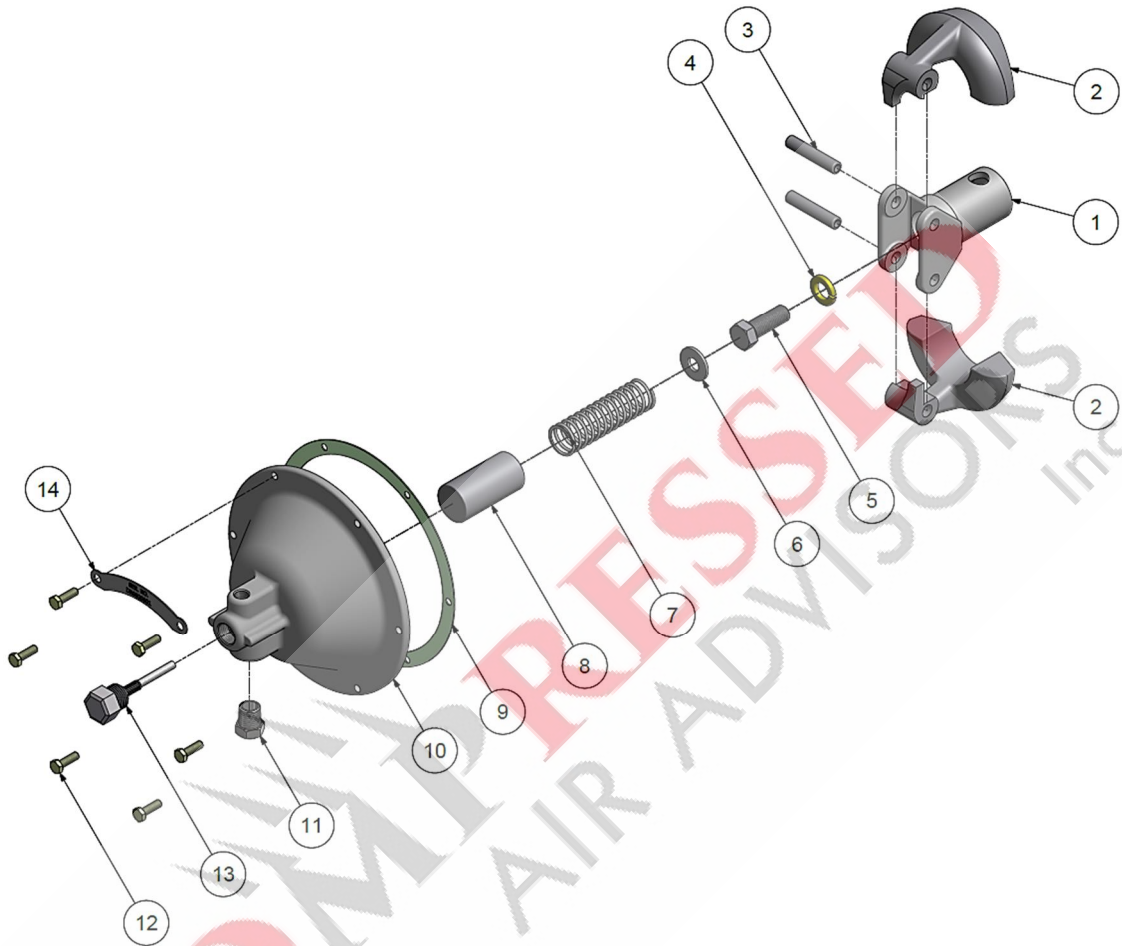

352CAP810-01  
Ref Drawing



## Centrifugal Unloader Group

### CENTRIFUGAL UNLOADER GROUP

**300CAP890**

1	SE583B	SPINDLE,GOVERNOR	1
2	SE582B	WEIGHT,GOVERNOR	2
3	SE592A	PIN, GOVERNOR WEIGHT	2
4	95B4Z	WASHER-LOCK	1
5	M2345	SCREW (torque @ 470 in-lbs)	1
6	M912A	SPACER,CENTRIFUGAL UNLOADER	1
7	SE590	SPRING,GOVERNOR	1
8	SE587	SLEEVE, SPRING	1
9	SE1489	GASKET,GOVERNOR COVER	1
10	RE10100A	GOVERNOR HOUSING COVER	1
11	Z4593	BREATHER	1
12	M3473	SCREW	6
13	Z12414A	RELEASE VALVE KIT	1
14	M3658	SERIAL NUMBER PLATE	1

### REPAIR PARTS

-	Z10887	COMPRESSOR GASKET SET (excludes valve gaskets)	1
---	--------	--	---

# Piston/Rod Group – Low Pressure

(2 per compressor)

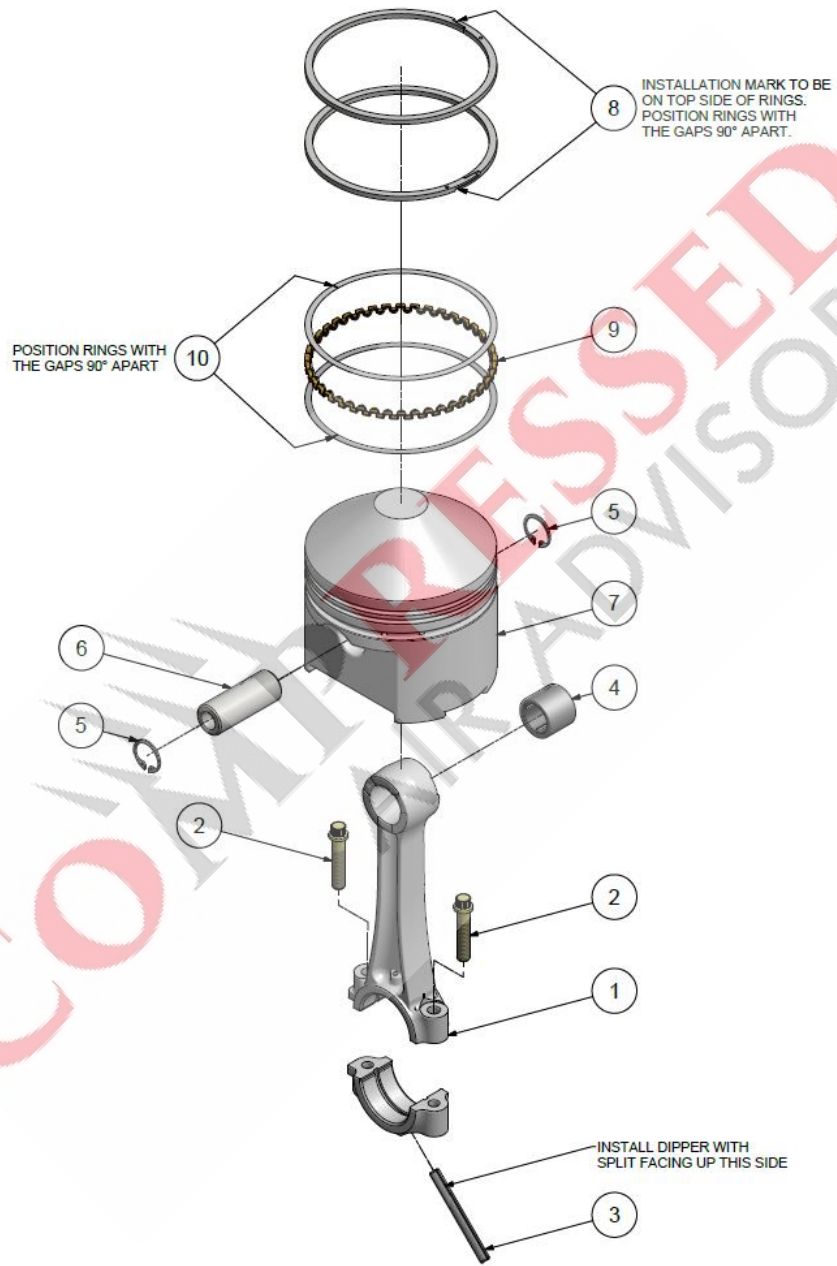

382CAP810-00  
Ref Drawing

## Piston/Rod Group – Low Pressure

(2 per compressor)

### LOW PRESSURE ROD/PISTON GROUP

**306CAP4056**

1	M1584*	CONNECTING ROD	1
2	M1583	SCREW (torque @ 230 in-lbs)	2
3	R1024	OIL DIPPER	1
4	R1037	BEARING, WRIST PIN	1
5	R10102	RING, RETAINING	2
6	R1021	PIN, PISTON	1
7	R154	PISTON	1
8	P02788A*	RING, PISTON	2
9	RE1410D1*	RING, EXPANDER	1
10	RE1410D2*	RING, RAIL	2

\*not sold separately – see repair parts

### REPAIR PARTS

1-4	Z752	CONNECTING ROD ASSEMBLY KIT	2
5-7	ZR154	PISTON KIT, LOW PRESSURE WITH PIN	2
8-10	Z798	RING SET, LOW PRESSURE	2
5-10	Z9101	PISTON & RING KIT, LOW PRESSURE	2
-	Z9085	COMPLETE RING SET, HIGH & LOW PRESSURE x 2	1

# Piston/Rod Group – High Pressure

(2 per compressor)

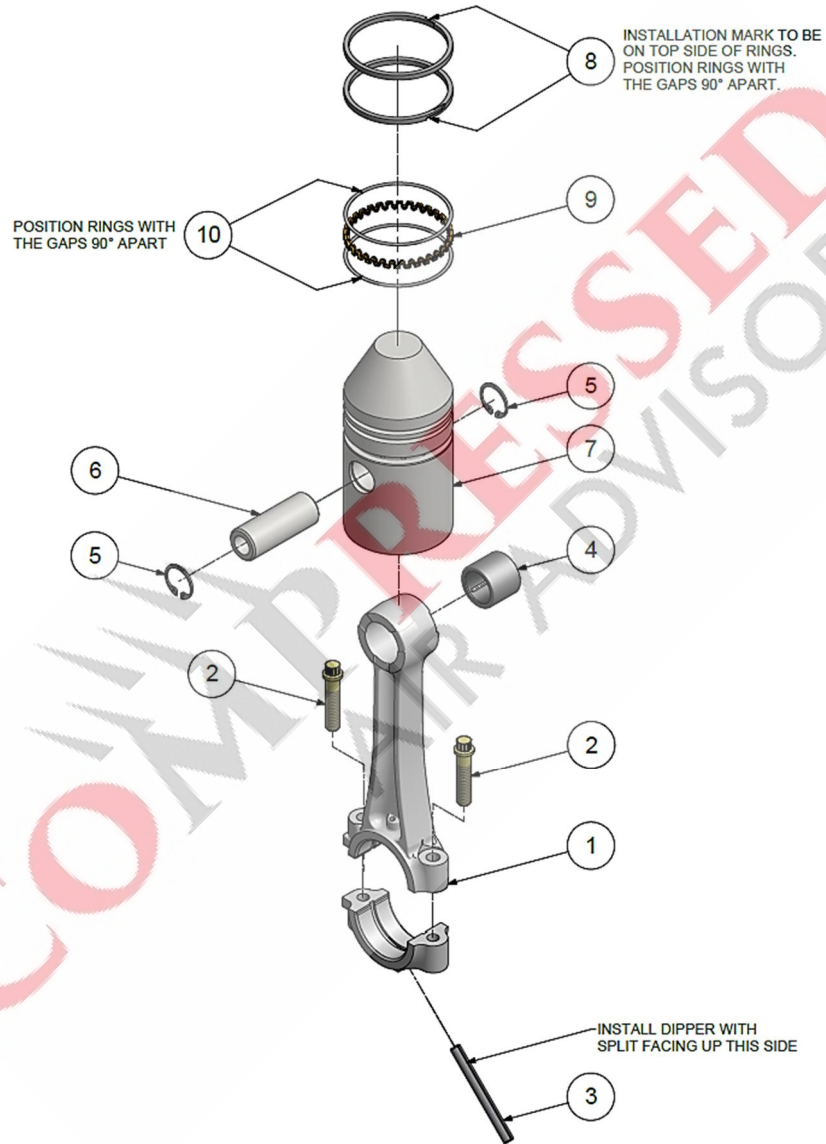

354CAP810-00  
Ref Drawing

## Piston/Rod Group – High Pressure

(2 per compressor)

### HIGH PRESSURE ROD/PISTON GROUP

**300CAP4056**

1	M1584*	CONNECTING ROD	1
2	M1583	SCREW (torque @ 230 in-lbs)	2
3	R1024	OIL DIPPER	1
4	R1037	BEARING, WRIST PIN	1
5	R10102	RING, RETAINING	2
6	R1021	PIN, PISTON	1
7	P02709C	PISTON	1
8	P02785A*	RING, PISTON	2
9	RE3610D1*	RING, EXPANDER	1
10	RE3610D2*	RING, RAIL	2

\*not sold separately – see repair parts

### REPAIR PARTS

1-4	Z752	CONNECTING ROD ASSEMBLY KIT	1
5-7	ZP2709C	PISTON KIT, HIGH PRESSURE WITH PIN	1
8-10	Z797	RING SET, HIGH PRESSURE	1
5-10	Z9100	PISTON & RING KIT, HIGH PRESSURE	1
-	Z9085	COMPLETE RING SET, HIGH & LOW PRESSURE x 2	1

# Cylinder Group – Standard

(2 per compressor)

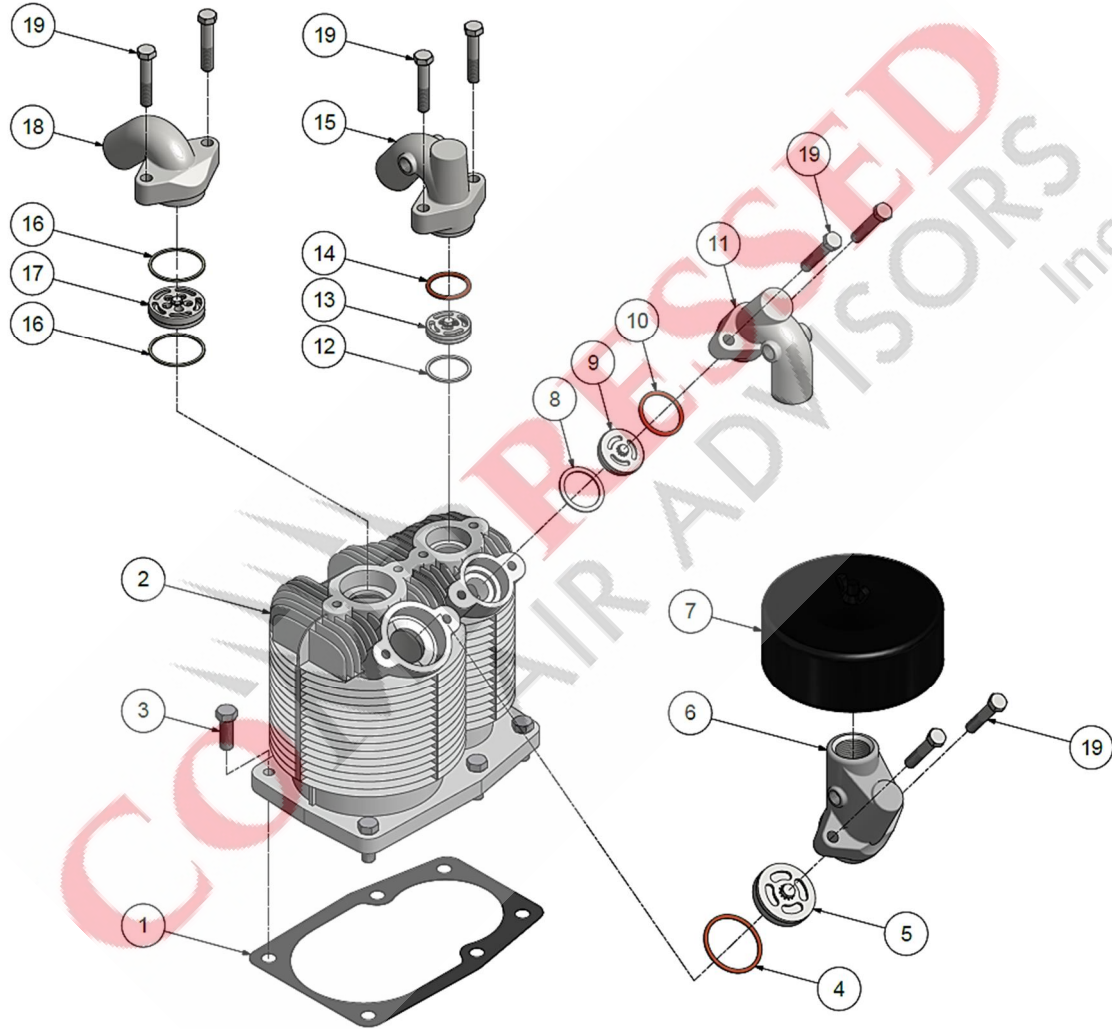

353CAP810-00  
Ref Drawing

## Cylinder Group – Standard

(2 per compressor)

### CYLINDER GROUP

**300CAP4042**

1	NR29A	GASKET,CYLINDER FLANGE	1
2	P12237D	CYLINDER	1
3	M2345	SCREW (torque @ 400 in-lbs)	6
4	CQP14832A	GASKET,VALVE,LP,COPPER	1
5	Z812A	VALVE,LP,INTAKE	1
6	P09669C	MANIFOLD,LP INTAKE	1
7	P04999A	FILTER SILENCER	1
8	P09171A	GASKET,VALVE,HP,ALUMINUM	1
9	Z11775	VALVE,HP,INTAKE	1
10	CQP14870A	GASKET,VALVE,HP,COPPER	1
11	P12302B	MANIFOLD,HP INTAKE	1
12	P04137A	GASKET,VALVE,HP,ALUMINUM	1
13	Z115A	VALVE,HP,EXHAUST	1
14	CQP14869A	GASKET,VALVE,HP,COPPER	1
15	P12303B	MANIFOLD,HP EXHAUST	1
16	P04135A	GASKET,VALVE,LP,ALUMINUM	2
17	Z813A	VALVE,LP,EXHAUST	1
18	RE102E	MANIFOLD,LP EXHAUST	1
19	655ED080	SCREW (torque @ 200 in-lbs)	8

### REPAIR PARTS

4, 5, 8, 9, 10, 12, 13, 14, 16, 17	Z5157	COMPLETE VALVE SET, WITH GASKET SET	1
4, 8, 10, 12, 14, 16	Z5158	COMPLETE VALVE GASKET SET	1
-	Z10887	COMPRESSOR GASKET SET (excludes valve gaskets)	1

# Cylinder Group – with Head Unloaders (optional)

(2 per compressor)

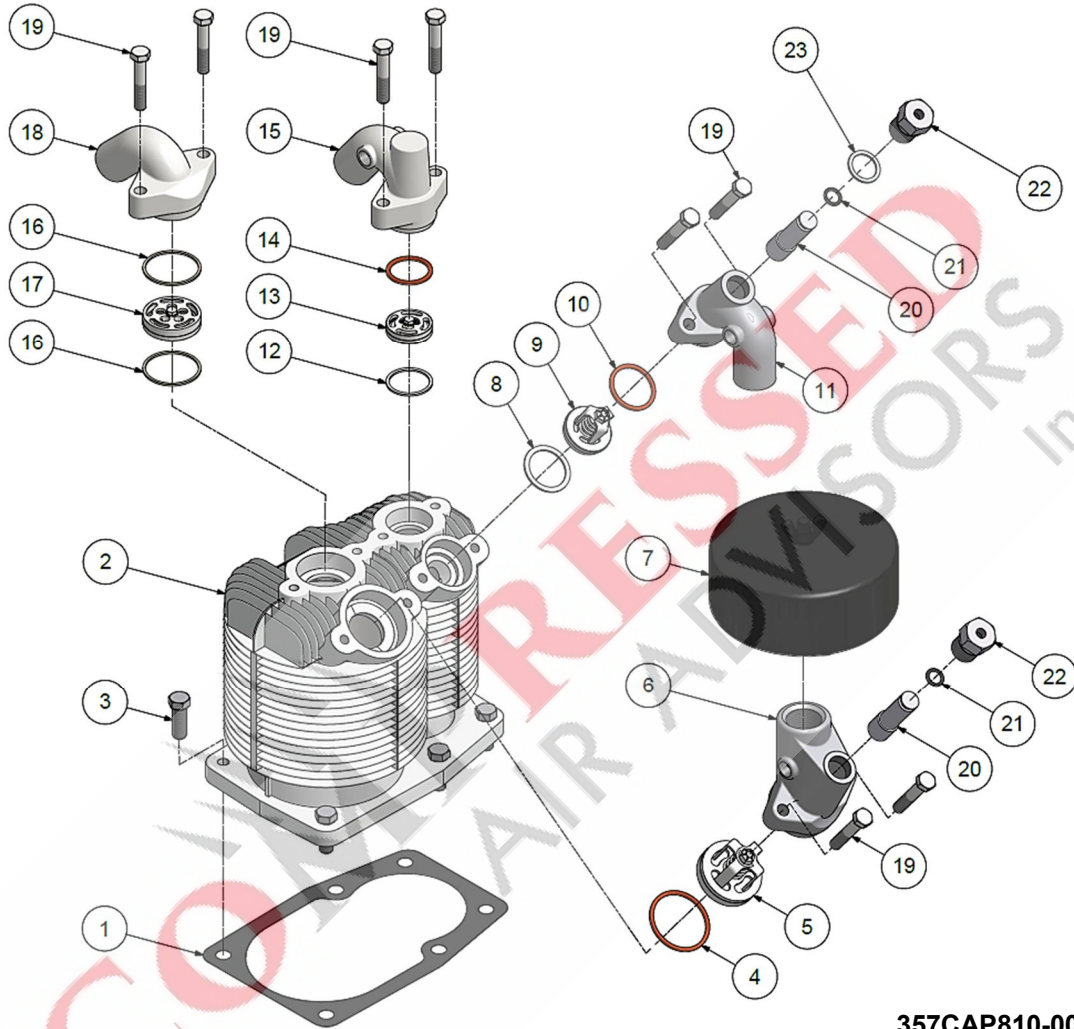

**357CAP810-00**  
**Ref Drawing**



## Cylinder Group – with Head Unloaders (optional)

(2 per compressor)

### CYLINDER GROUP - HEAD UNLOADERS

**302CAP4042**

1	NR29A	GASKET,CYLINDER FLANGE	1
2	P12237D	CYLINDER	1
3	M2345	SCREW (torque @ 400 in-lbs)	6
4	CQP14832A	GASKET,VALVE,LP,COPPER	1
5	Z4877A	VALVE,LP,INTAKE,UNLOADER	1
6	P09670C	MANIFOLD,LP INTAKE	1
7	P04999A	FILTER SILENCER	1
8	P09171A	GASKET,VALVE,HP,ALUMINUM	1
9	Z11936	VALVE,HP,INTAKE,UNLOADER	1
10	CQP14870A	GASKET,VALVE,HP,COPPER	1
11	P12304B	MANIFOLD,HP INTAKE,HU	1
12	P04137A	GASKET,VALVE,HP,ALUMINUM	1
13	Z115A	VALVE,HP,EXHAUST	1
14	CQP14869A	GASKET,VALVE,HP,COPPER	1
15	P12303B	MANIFOLD,HP EXHAUST	1
16	P04135A	GASKET,VALVE,LP,ALUMINUM	2
17	Z813A	VALVE,LP,EXHAUST,SUB-ASSY	1
18	RE102E	MANIFOLD,EXHAUST LP	1
19	655ED080	SCREW (torque @ 200 in-lbs)	8
20	P09923A	UNLOADER PISTON	2
21	P02547A	O-RING	2
22	P02306B	VALVE,CYLINDER,FOR HU	2
23	P00746A	GASKET	1

### REPAIR PARTS

4, 5, 8, 9, 10, 12, 13, 14, 16, 17	Z6796	COMPLETE VALVE SET, WITH GASKET SET	1
4, 8, 10, 12, 14, 16	Z5158	COMPLETE VALVE GASKET SET	1
-	Z10887	COMPRESSOR GASKET SET (excludes valve gaskets)	1
-	Z9145	KIT, HEAD UNLOADER CONVERSION (includes manifolds, unloader valves assemblies, pilot valve, fittings and tubing)	1

# Tubing and Control Group – Standard

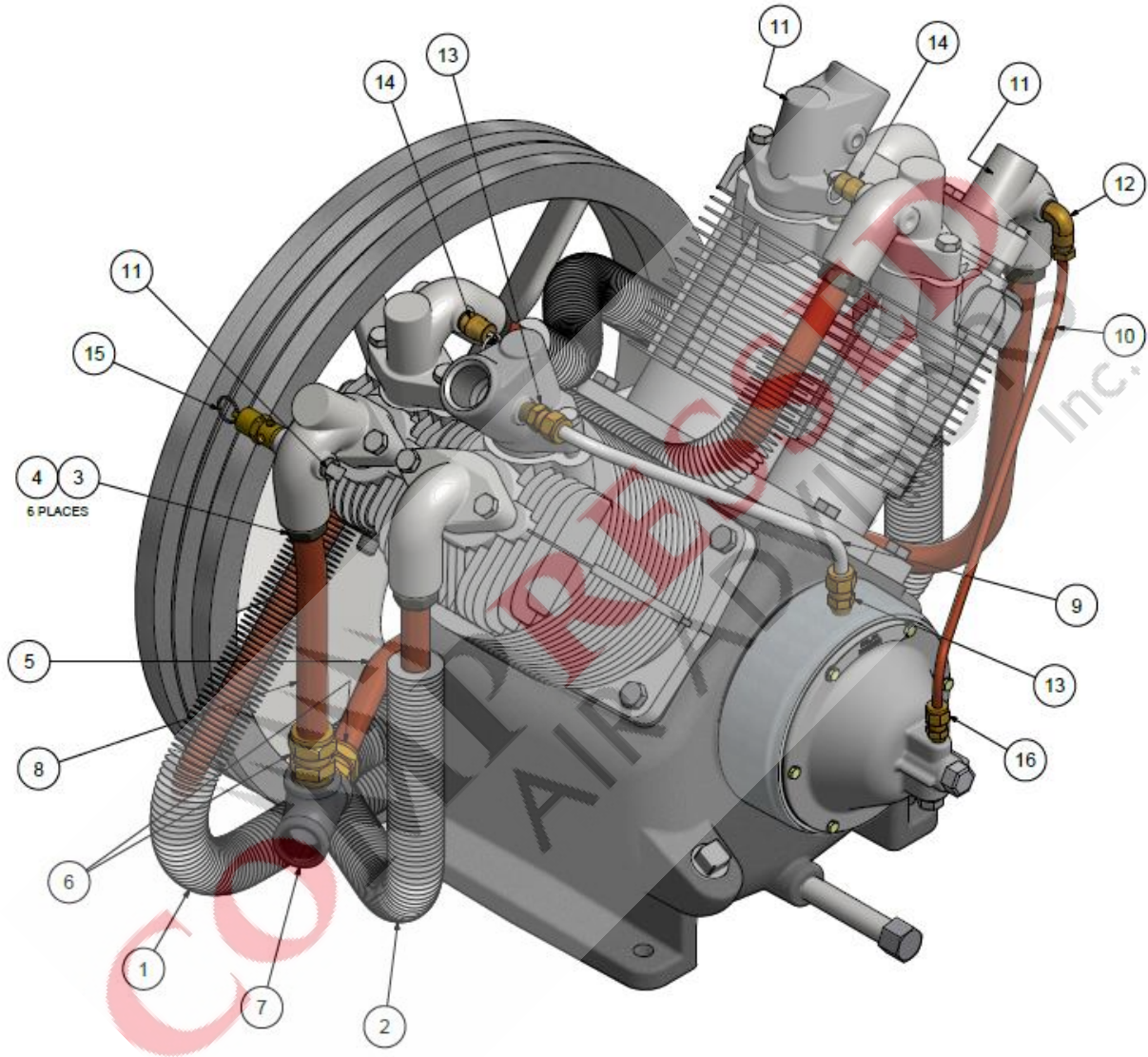

364CAP810-00  
Ref Drawing

## Tubing and Control Group – Standard

TUBING & CONTROL GROUP			301CAP272
1	P12512D	INTERCOOLER,RIGHT	1
2	P12513D	INTERCOOLER,LEFT	1
3	SE541	COMPRESSION NUT	6
4	SE542	COMPRESSION FERRULE	6
5	P08132B	DISCHARGE TUBE,RIGHT MANIFOLD	1
6	M2867	COMPRESSION FITTING, STRAIGHT	2
7	M480	PIPE TEE	1
8	301CAP294	DISCHARGE TUBE,LEFT MANIFOLD	1
9	UB375B	BREATHER TUBE	1
10	P08133B	UNLOADER TUBE	1
11	64AA5	PIPE PLUG	2
12	86A40	COMPRESSION FITTING, ELBOW	1
13	M2864	COMPRESSION FITTING, STRAIGHT	2
14	M3685	PRESSURE RELIEF VALVE, 75 PSIG	2
15	P09704A	PRESSURE RELIEF VALVE, 270 PSIG	1
16	M2863	COMPRESSION FITTING, STRAIGHT	1

# Tubing and Control Group – with Head Unloaders (optional)

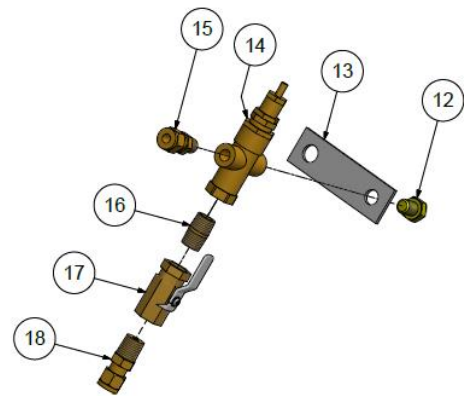
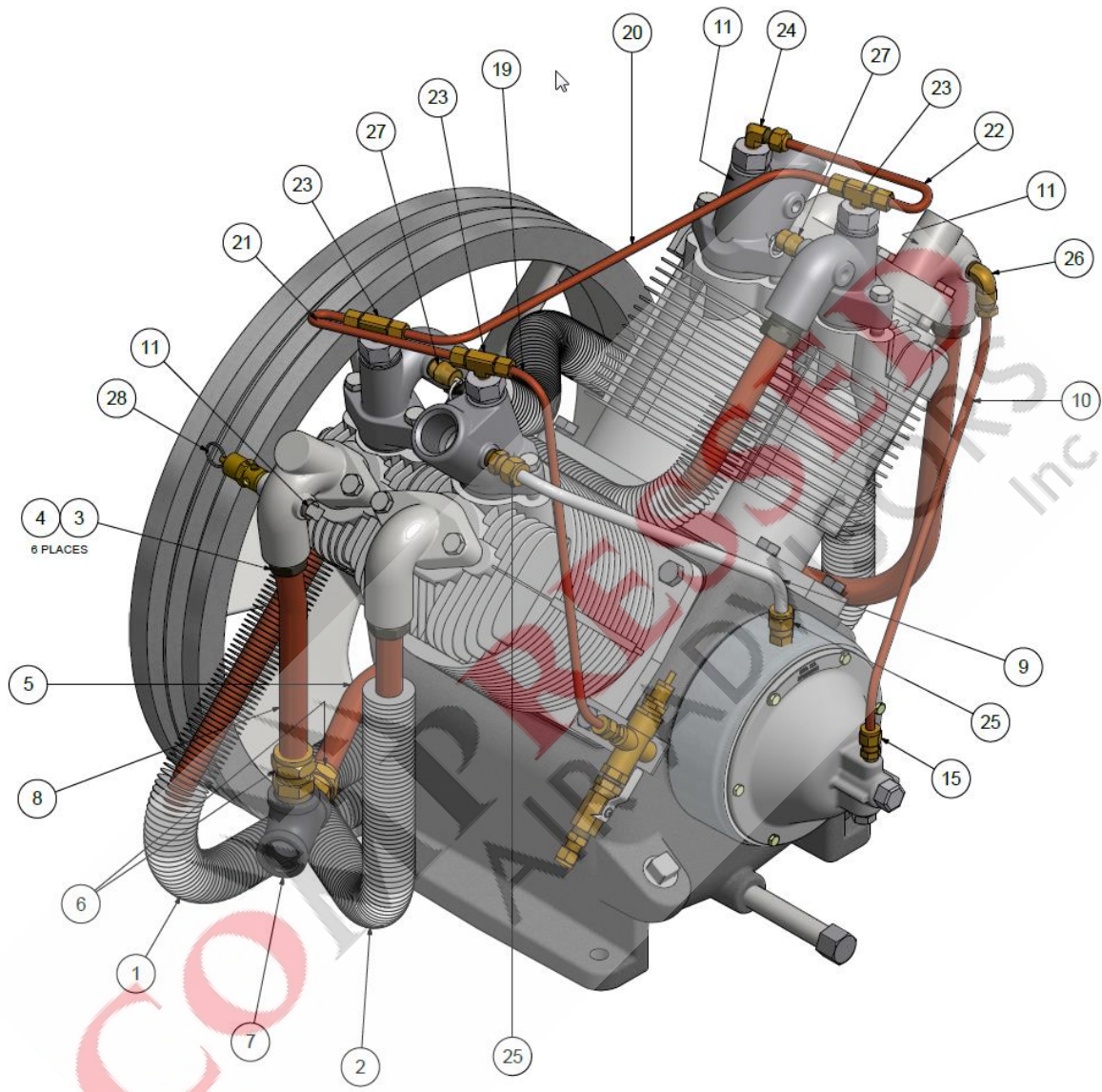

365CAP810-00  
Ref Drawing

## Tubing and Control Group – with Head Unloaders (optional)

### TUBING & CONTROL GROUP - HEAD UNLOADERS

**303CAP272**

1	P12512D	INTERCOOLER,RIGHT	1
2	P12513D	INTERCOOLER,LEFT	1
3	SE541	COMPRESSION NUT	6
4	SE542	COMPRESSION FERRULE	6
5	P08132B	DISCHARGE TUBE,RIGHT MANIFOLD	1
6	M2867	COMPRESSION FITTING, STRAIGHT	2
7	M480	PIPE TEE	1
8	301CAP294	DISCHARGE TUBE,LEFT MANIFOLD	1
9	UB375B	BREATHER TUBE	1
10	P08133B	UNLOADER TUBE	1
11	64AA5	PIPE PLUG	3
12	M3465	SCREW	1
13	M807	BRACKET,PILOT VALVE MOUNTING	1
14	M2854	PILOT VALVE 90-120# (125 psi discharge)	1
14	M2853	PILOT VALVE 140-170# (175 psi discharge)	1
15	M2863	COMPRESSION FITTING, STRAIGHT	2
16	63Z15	PIPE NIPPLE	1
17	VP1022988	BALL VALVE	1
18	M2862	COMPRESSION FITTING, STRAIGHT	1
19	P08463B	ACTUATING TUBE	1
20	P08461B	INTERMEDIATE TUBE	1
21	302CAP294	LEFT MANIFOLD TUBE	1
22	303CAP294	RIGHT MANIFOLD TUBE	1
23	M2879	COMPRESSION FITTING, TEE	3
24	M2868	COMPRESSION FITTING, ELBOW	1
25	M2864	COMPRESSION FITTING, STRAIGHT	2
26	86A40	COMPRESSION FITTING, ELBOW	1
27	M3685	PRESSURE RELIEF VALVE, 75 PSIG	2
28	P09704A	PRESSURE RELIEF VALVE, 270 PSIG	1

### REPAIR PARTS

-	Z9145	KIT, HEAD UNLOADER CONVERSION (includes manifolds, unloader valves assemblies, pilot valve, fittings and tubing)	1
---	-------	--	---

# Tubing and Control Group – Engine Driven

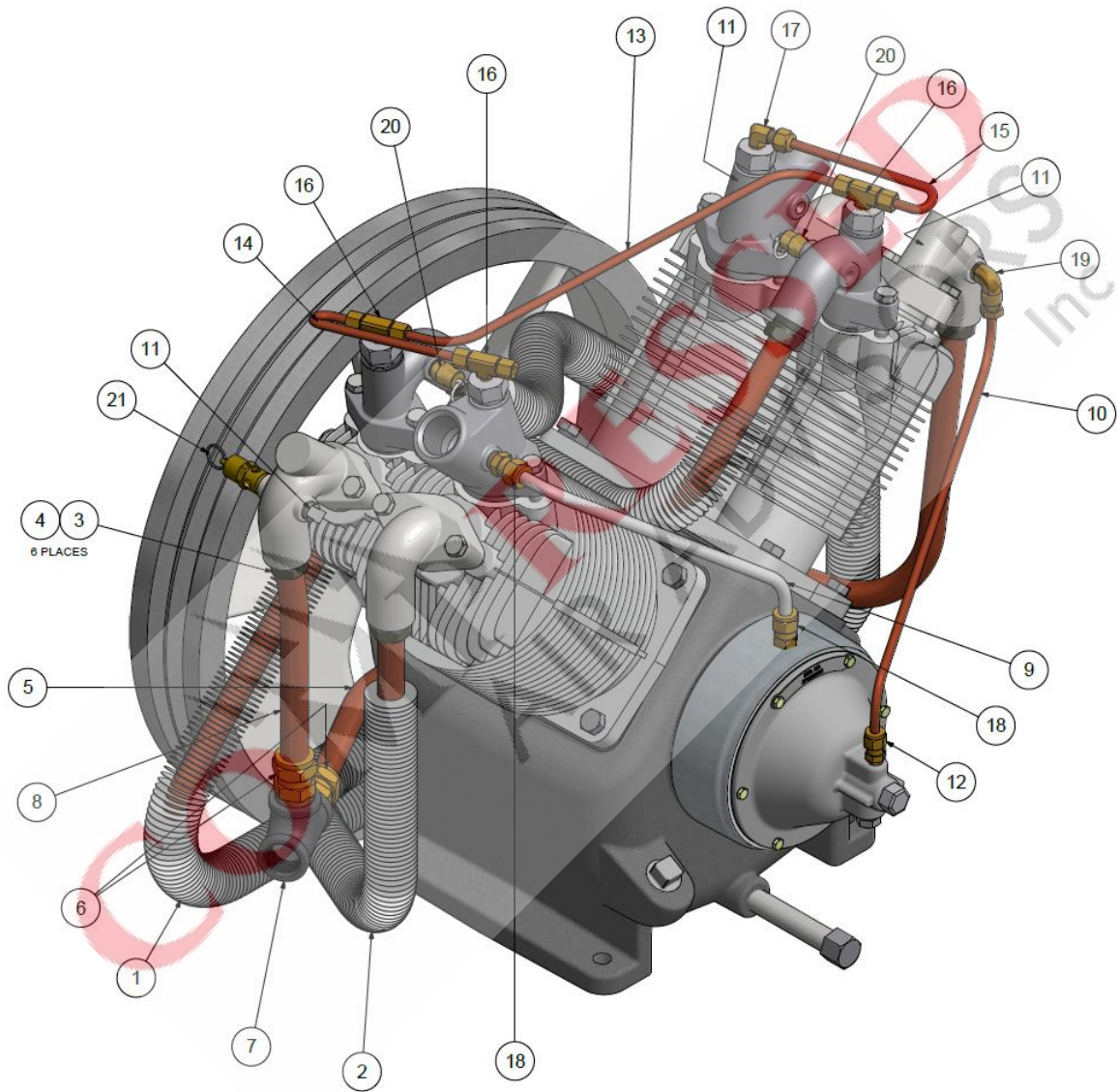

386CAP810-00  
Ref Drawing

## Tubing and Control Group – Engine Driven

### TUBING & CONTROL GROUP – ENGINE DRIVEN

**310CAP272**

1	P12512D	INTERCOOLER,RIGHT	1
2	P12513D	INTERCOOLER,LEFT	1
3	SE541	COMPRESSION NUT	6
4	SE542	COMPRESSION FERRULE	6
5	P08132B	DISCHARGE TUBE,RIGHT MANIFOLD	1
6	M2867	COMPRESSION FITTING, STRAIGHT	2
7	M480	PIPE TEE	1
8	301CAP294	DISCHARGE TUBE,LEFT MANIFOLD	1
9	UB375B	BREATHER TUBE	1
10	P08133B	UNLOADER TUBE	1
11	64AA5	PIPE PLUG	3
12	M2863	COMPRESSION FITTING, STRAIGHT	1
13	P08461B	INTERMEDIATE TUBE	1
14	302CAP294	LEFT MANIFOLD TUBE	1
15	303CAP294	RIGHT MANIFOLD TUBE	1
16	M2879	COMPRESSION FITTING, TEE	3
17	M2868	COMPRESSION FITTING, ELBOW	1
18	M2864	COMPRESSION FITTING, STRAIGHT	2
19	86A40	COMPRESSION FITTING, ELBOW	1
20	M3685	PRESSURE RELIEF VALVE, 75 PSIG	2
21	P09704A	PRESSURE RELIEF VALVE, 270 PSIG	1

## High Temperature Switch (optional)



TEN008397-00  
Ref Drawing

### HIGH TEMPERATURE SWITCH

TEN008397

Part Number	Description	Quantity
1	TEN001792 SWITCH, HIGH TEMP, 450F	1
2	003FE98 CORD GRIP	1
3	TEN008088 SEALING RING	1
4	TEN008089 LOCK NUT	1
5	M968B PIPE CROSS	1
6	M482 PIPE BUSHING	1



## Low Oil Shutdown Control (optional)

TEN008801-00  
Ref Drawing

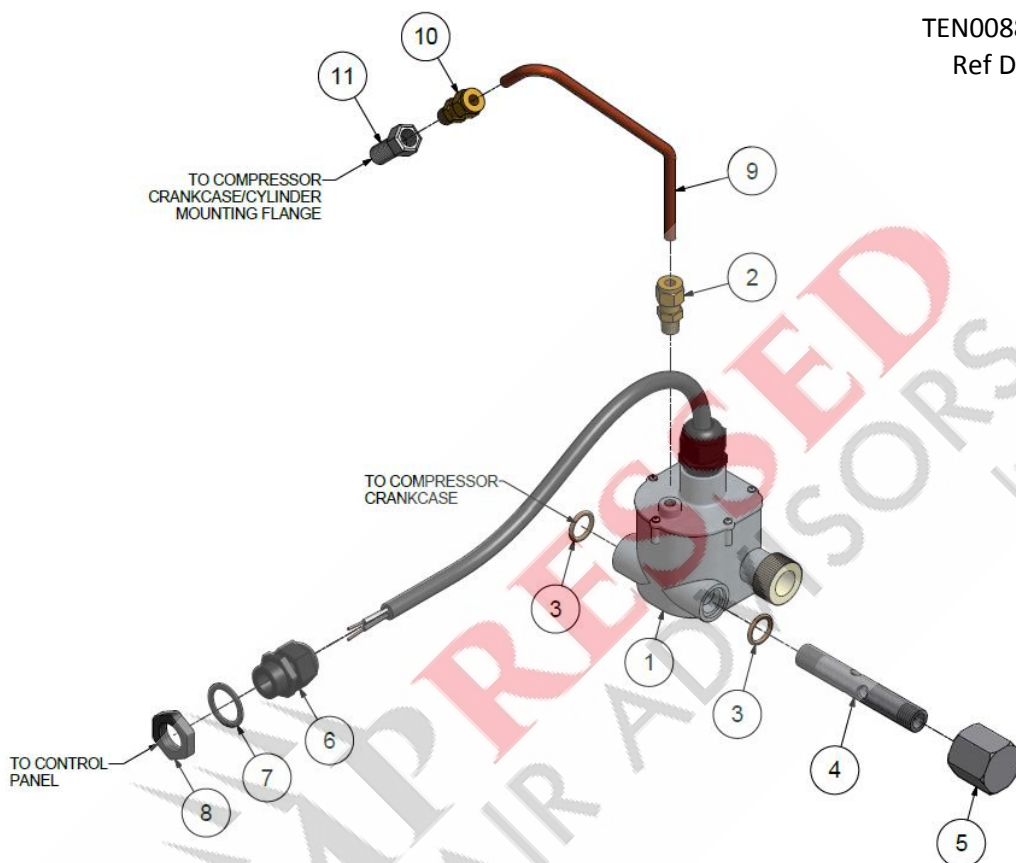

### LOW OIL SHUTDOWN CONTROL

TEN008801

1	TEN008741	SWITCH-LOW OIL SHUTDOWN CONTROL	1
2	M2863	COMPRESSION FITTING, STRAIGHT	1
3	2009222	O-RING	2
4	CC1153304	OIL TUBE	1
5	LO30	RETAINER CAP	1
6	003FE98	CORD GRIP	1
7	TEN008088	SEALING RING	1
8	TEN008089	LOCK NUT	1
9	CC1007636	VENT TUBE	1
10	M2863	COMPRESSION FITTING, STRAIGHT	1
11	P13757A	VENT FITTING	1

### REPAIR PARTS

1-11	TEN008809	KIT-LOSC w/CABLE, COMPLETE	1
1-4	TEN008855	KIT-LOSC w/CABLE, REPLACEMENT	1

## Section 3 – Electric Packages

### Vertical Package

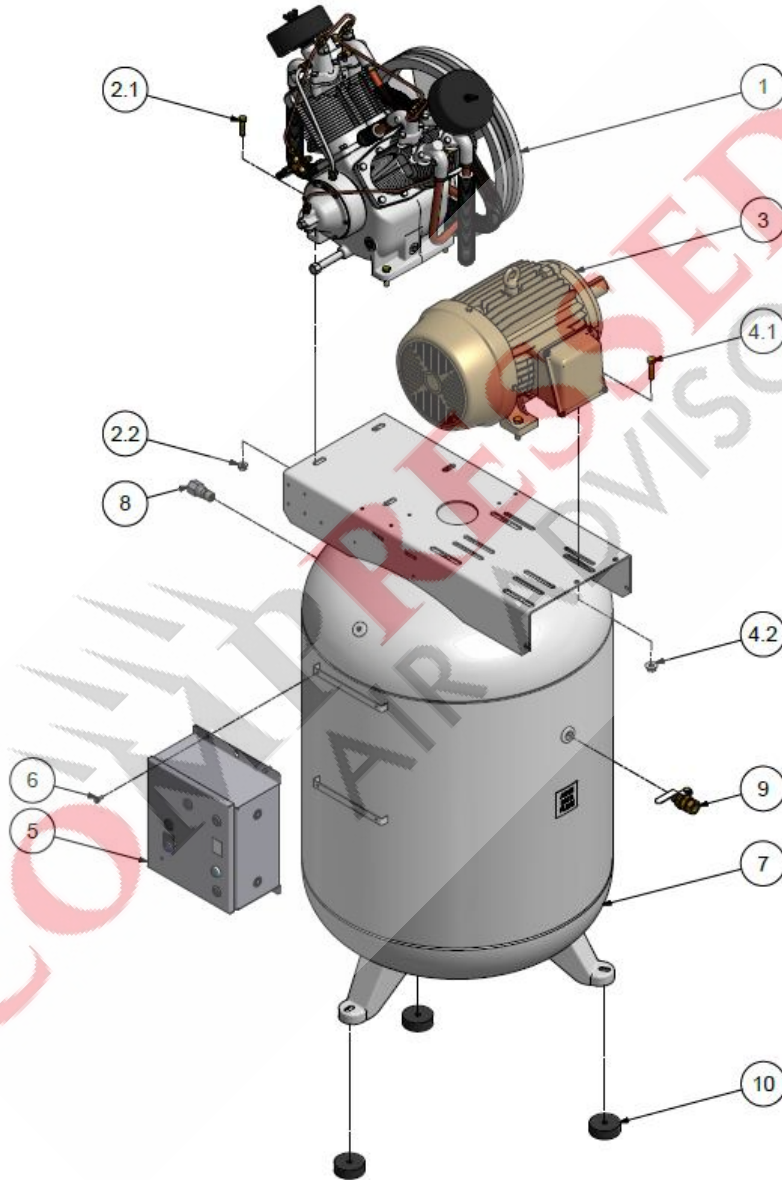

412CAS810-00  
Ref Drawing

## Vertical Package

### COMPRESSOR

**R2-30A**

1	R2-30A-P02	R30 COMPRESSOR	1
1	R2-30A-P05	R30 COMPRESSOR W/HEAD UNLOADERS	1

### COMPRESSOR MOUNTING

**401CAS4017**

2.1	M3466	SCREW	4
2.2	M3484	NUT	4

### MOTOR

3	-	SEE MOTOR LISTING ON FOLLOWING PAGE	1
---	---	-------------------------------------	---

### MOTOR MOUNTING

**402CAS4015**

**403CAS4015**

4.1	M3460	SCREW (7.5HP,10HP)	4
4.1	M3470	SCREW (15HP)	4
4.2	M3483	NUT (7.5HP,10HP)	4
4.2	M3486	NUT (15HP)	4

### SIMPLEX CONTROL PANEL

5	-	SEE PART NUMBER LISTING IN CONTROL PANEL MANUAL	1
---	---	---	---

### PANEL MOUNTING

6	M3349	SCREW	4
---	-------	-------	---

### VERTICAL AIR RECEIVER

7	TEN005604	RECEIVER, 80 GALLON VERTICAL, 200PSI	1
7	TEN007644	RECEIVER, 80 GALLON VERTICAL, SQUAT,200PSI	1
7	TEN007003	RECEIVER, 120 GALLON VERTICAL, 200PSI	1

### CHECK VALVE

8	P05822A	CHECK VALVE	1
---	---------	-------------	---

### BALL VALVE

9	CQM3756	BALL VALVE	1
---	---------	------------	---

### VIBRATION ISOLATORS (OPTIONAL)

10	P14607A	ISOLATOR,VIBRATION,3"DIA.	3
----	---------	---------------------------	---

# Horizontal Package – Simplex

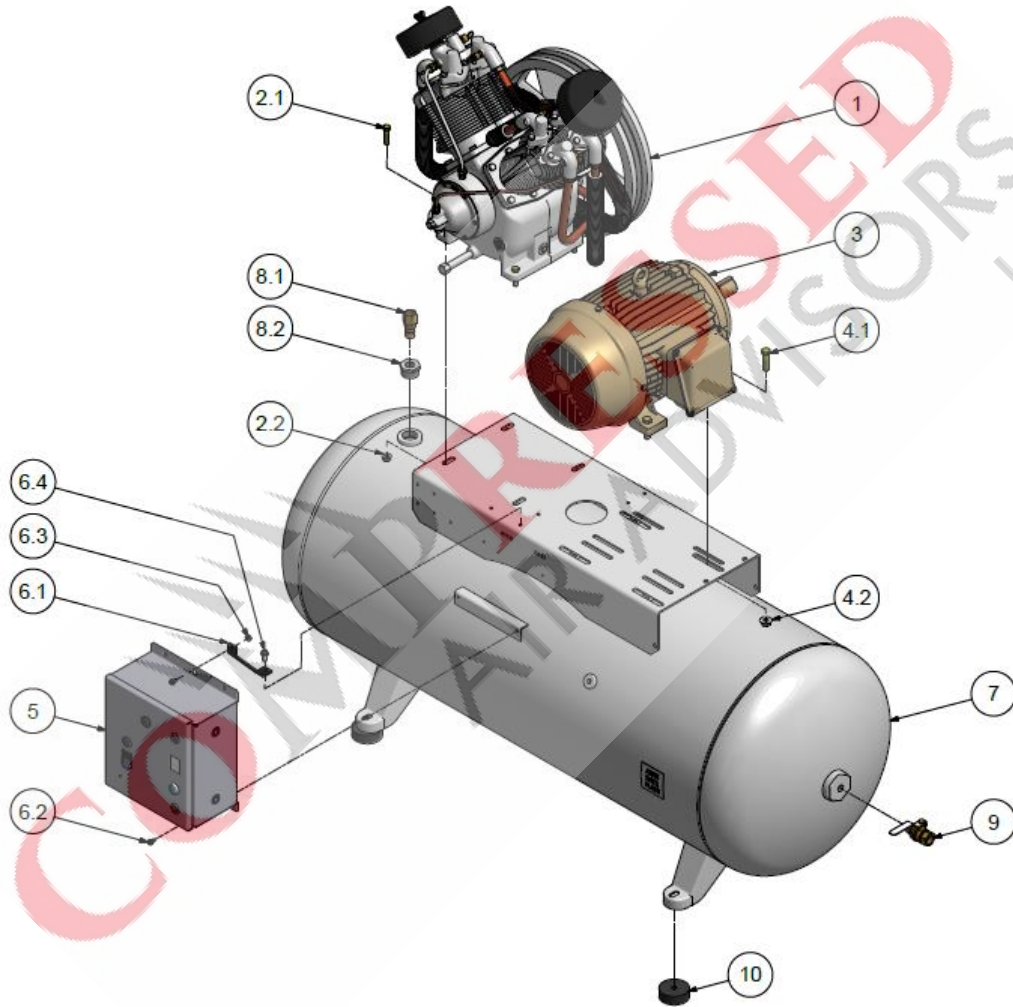

413CAS810-00  
Ref Drawing

## Horizontal Package – Simplex

### COMPRESSOR

**R2-30A**

1	R2-30A-P02	R30 COMPRESSOR	1
1	R2-30A-P05	R30 COMPRESSOR W/HEAD UNLOADERS	1

### COMPRESSOR MOUNTING

**401CAS4017**

2.1	M3466	SCREW	4
2.2	M3484	NUT	4

### MOTOR

3	-	SEE MOTOR LISTING ON FOLLOWING PAGE	1
---	---	-------------------------------------	---

**402CAS4015**

**403CAS4015**

### MOTOR MOUNTING

4.1	M3460	SCREW (7.5HP,10HP)	4
4.1	M3470	SCREW (15HP)	4
4.2	M3483	NUT (7.5HP,10HP)	4
4.2	M3486	NUT (15HP)	4

### SIMPLEX CONTROL PANEL

5	-	SEE PART NUMBER LISTING IN CONTROL PANEL MANUAL	1
---	---	---	---

### PANEL MOUNTING

6.1	TEN008117	BRACKET-PANEL, 80GL HORIZONTAL	1
6.1	TEN008118	BRACKET-PANEL, 120GL HORIZONTAL	1
6.1	TEN008119	BRACKET-PANEL, 240GL HORIZONTAL	1
6.2	M3349	SCREW	3
6.3	50AW3	NUT	1
6.4	M1454	SCREW	1

### HORIZONTAL AIR RECEIVER / BASE MOUNT

7	TEN007326	RECEIVER, 80 GALLON HORIZONTAL, 200PSI	1
7	TEN005639	RECEIVER, 120 GALLON HORIZONTAL, 200PSI	1
7	TEN007572	RECEIVER, 240 GALLON HORIZONTAL, 200PSI	1
7	P03970C	BASE MOUNT PLATE (NOT SHOWN)	1

### CHECK VALVE

8.1	P05822A	VALVE,CHECK,INTANK,3/4"	1
8.2	M953B	BUSHING (FOR 120 & 240GL)	1

### BALL VALVE

9	CQM3756	BALL VALVE	1
---	---------	------------	---

### VIBRATION ISOLATORS (OPTIONAL)

10	P14608A	ISOLATOR,VIBRATION,4"DIA.	4
----	---------	---------------------------	---

## Electric Motor List

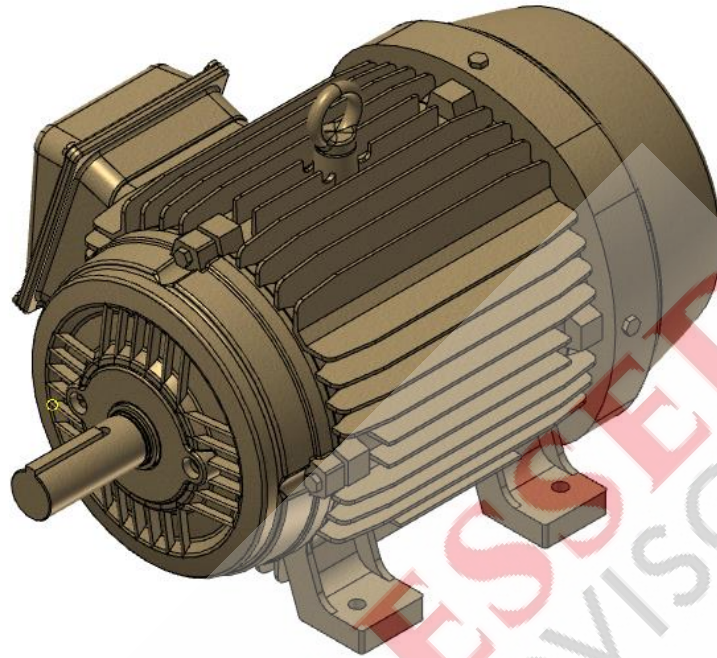

MOTOR								R2-30A
3	VP1037934	MOTOR	7.5HP	208V	60HZ	1PH	ODP	1
3	VP1045830	MOTOR	7.5HP	208V	60HZ	1PH	TEFC	1
3	P10397A	MOTOR	7.5HP	230V	60HZ	1PH	ODP	1
3	VP1045830	MOTOR	7.5HP	230V	60HZ	1PH	TEFC	1
3	24CA6652	MOTOR	7.5HP	208V	60HZ	3PH	ODP	1
3	24CA6654	MOTOR	7.5HP	208V	60HZ	3PH	TEFC	1
3	24CA6655	MOTOR	7.5HP	230V-460V	60HZ	3PH	ODP	1
3	24CA6656	MOTOR	7.5HP	230V-460V	60HZ	3PH	TEFC	1
3	24CA6657	MOTOR	7.5HP	575V	60HZ	3PH	ODP	1
3	24CA6658	MOTOR	7.5HP	575V	60HZ	3PH	TEFC	1
3	24CA6660	MOTOR	10HP	208V	60HZ	3PH	ODP	1
3	24CA6662	MOTOR	10HP	208V	60HZ	3PH	TEFC	1
3	24CA6663	MOTOR	10HP	230V-460V	60HZ	3PH	ODP	1
3	24CA6664	MOTOR	10HP	230V-460V	60HZ	3PH	TEFC	1
3	24CA6665	MOTOR	10HP	575V	60HZ	3PH	ODP	1
3	24CA6666	MOTOR	10HP	575V	60HZ	3PH	TEFC	1
3	24CA6668	MOTOR	15HP	208V	60HZ	3PH	ODP	1
3	24CA6670	MOTOR	15HP	208V	60HZ	3PH	TEFC	1
3	24CA6671	MOTOR	15HP	230V-460V	60HZ	3PH	ODP	1
3	24CA6672	MOTOR	15HP	230V-460V	60HZ	3PH	TEFC	1
3	24CA6673	MOTOR	15HP	575V	60HZ	3PH	ODP	1
3	24CA6674	MOTOR	15HP	575V	60HZ	3PH	TEFC	1

## Tank Drain – Manual

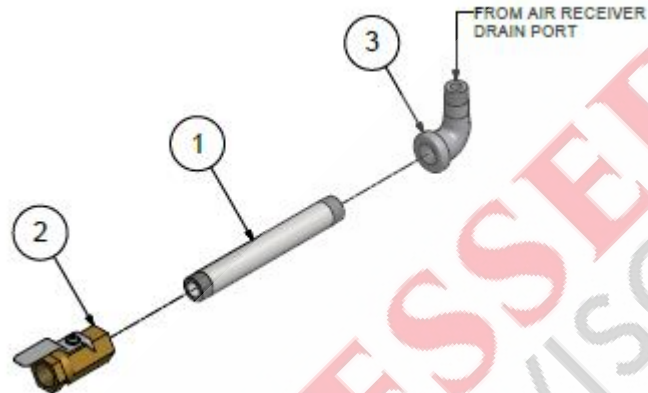

401CAS810-01  
Ref Drawing

### MANUAL TANK DRAIN (80GL HORIZONTAL, 80-120GL VERTICAL)

CC1044092

1	M933B	PIPE NIPPLE, 4"	1
2	VP1022988	BALL VALVE	1
3	M980B	PIPE ELBOW	1

### MANUAL TANK DRAIN (120-240GL HORIZONTAL)

401CAS4027

1	M933B	PIPE NIPPLE, 4"	1
2	VP1022988	BALL VALVE	1
3	M980B	PIPE ELBOW	1
4	M1318 (NOT SHOWN)	PIPE BUSHING	1

## Tank Drain – Electric (optional)

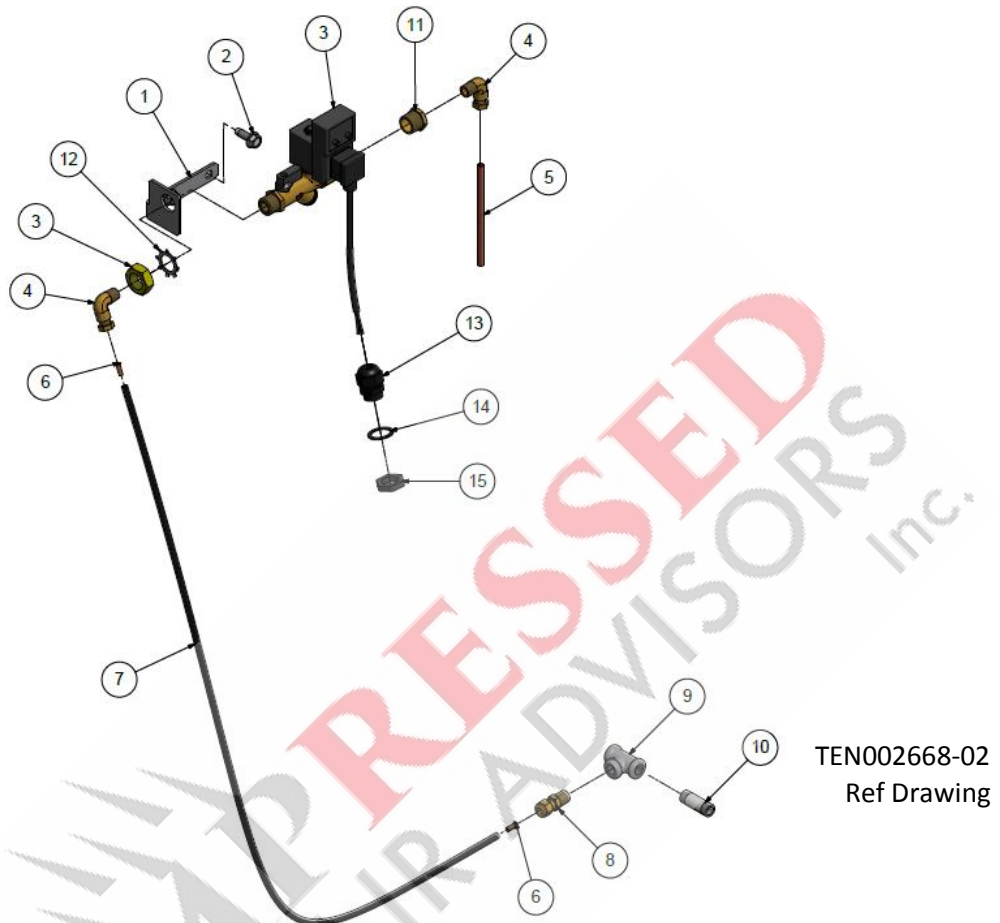

### ELECTRIC TANK DRAIN

TEN002668

1	CC1049403	BRACKET	1
2	M1454	SCREW	2
3	TEN001368	VALVE,ETD,W/STRAINER	1
4	86A40	COMPRESSION FITTING, ELBOW	2
5	M2471	COPPER TUBING	6 in
6	P10118A	TUBE INSERT	2
7	P08084A	PLASTIC TUBING	5 ft
8	M2862	COMPRESSION FITTING, STRAIGHT	1
9	M1003B	PIPE TEE	1
10	M1016B	PIPE NIPPLE	1
11	M3080	PIPE BUSHING	1
12	95H8	LOCK WASHER	1
13	003FE98	CORD GRIP	1
14	TEN008088	SEALING RING	1
15	TEN008089	LOCK NUT	1



## Control Group – Start/Stop

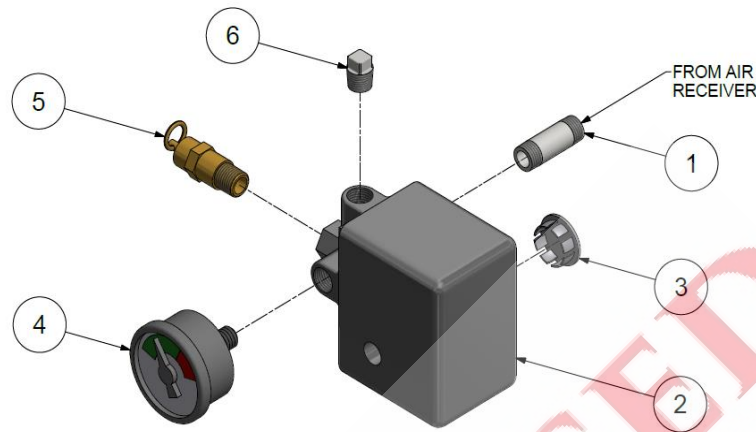

402CAS810-01  
Ref Drawing  
(Nema 1)

### START/STOP CONTROL, NEMA 1

401CAS4052  
403CAS4052

1	M1016B	PIPE NIPPLE, 1.5"	1
2	P14205A	SWITCH,PRESSURE,95-125 (125 psi discharge)	1
2	P14202A	SWITCH,PRESSURE,140-175 (175 psi discharge)	1
3	M2352	KNOCKOUT HOLE PLUG	1
4	M519C	PRESSURE GAUGE	1
5	M2843	PRESSURE RELIEF VALVE, 200#	1
6	64AA5	PIPE PLUG	1

### START/STOP CONTROL, NEMA 4

405CAS4052

1	M1016B	PIPE NIPPLE, 1.5"	1
2	P07333A	SWITCH,PRESSURE,N4 (125 or 175 psi discharge)	1
4	M519C	PRESSURE GAUGE	1
5	M2843	PRESSURE RELIEF VALVE, 200#	1
-	64K1 (not shown)	PIPE CROSS	1

## Control Group – Dual Control (optional)

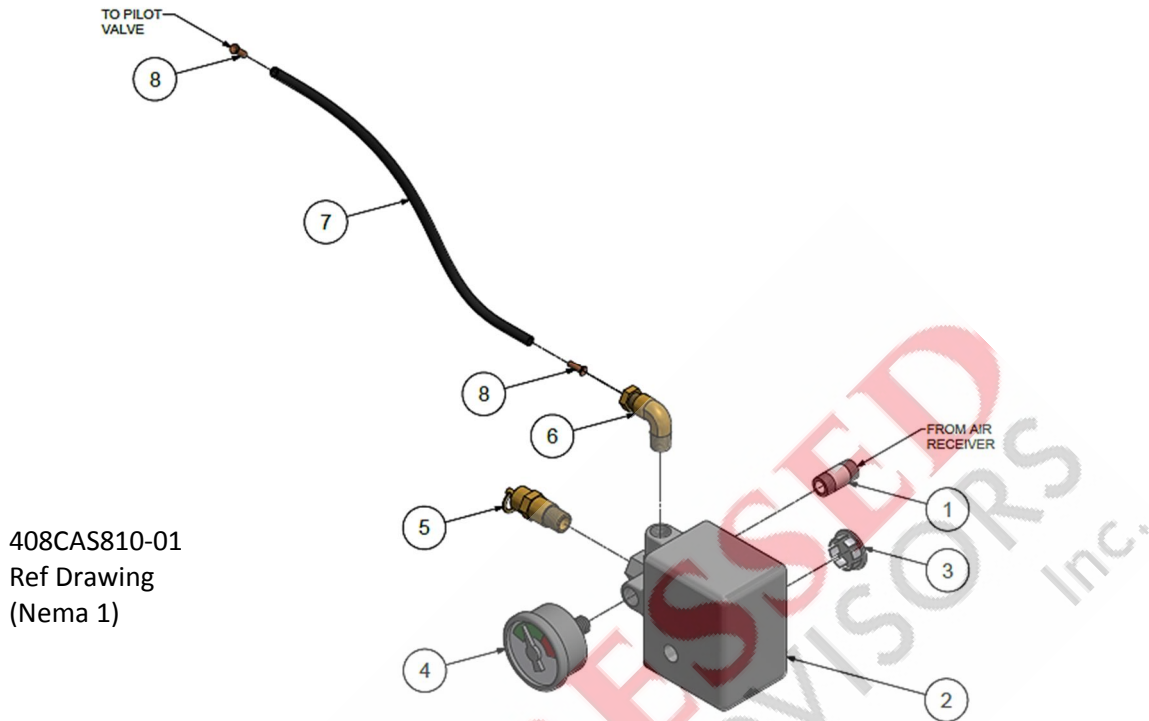

### DUAL CONTROL, NEMA 1

**407CAS4052**  
**411CAS4052**

1	M1016B	NIPPLE	1
2	P14205A	SWITCH,PRESSURE,95-125 (125 psi discharge)	1
2	P14202A	SWITCH,PRESSURE,140-175 (175 psi discharge)	1
3	M2352	KNOCKOUT HOLE PLUG	1
4	M519C	PRESSURE GAUGE	1
5	M2843	PRESSURE RELIEF VALVE, 200#	1
6	86A40	COMPRESSION FITTING, ELBOW	1
7	P08084A	PLASTIC TUBING	3.5 ft
8	P10118A	TUBE INSERT	2

### DUAL CONTROL, NEMA 4

**409CAS4052**  
**413CAS4052**

1	M1016B	NIPPLE	2
-	M1003B (not shown)	PIPE TEE	1
-	64K1 (not shown)	PIPE CROSS	1
2	P07333A	SWITCH,PRESSURE,N4 (125 or 175 psi discharge)	1
4	M519C	PRESSURE GAUGE	1
5	M2843	PRESSURE RELIEF VALVE, 200#	1
6	86A40	COMPRESSION FITTING, ELBOW	1
7	P08084A	PLASTIC TUBING	3 ft
8	P10118A	TUBE INSERT	2

## Power Transmission

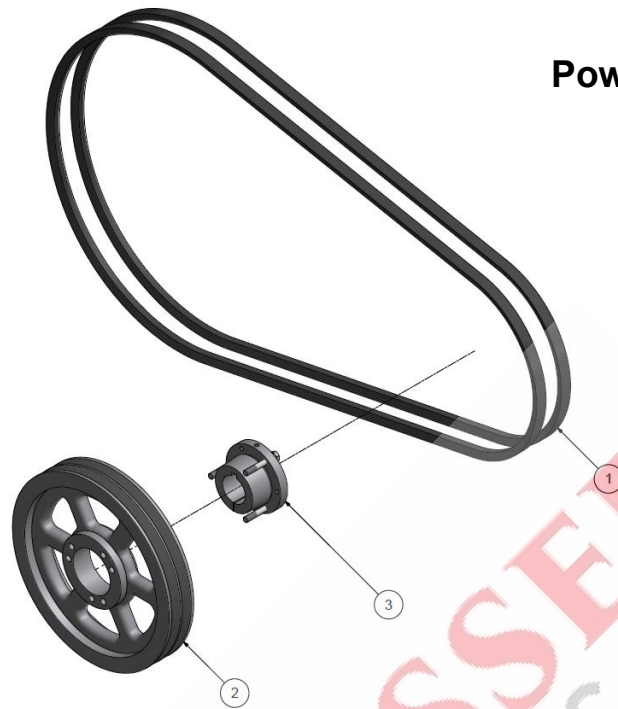

414CAS810-00

Ref Drawing

### TRANSMISSION GROUP (R30,125PSI,7.5HP)

Z2679

1	B80	V BELT	2
2	M7011D	PULLEY,7.00 OD,1-3/8 BORE,2VB	1
3	M568	SET-SCREW,SOCKET 3/8-16 X 3/8 (NOT SHOWN)	1

### TRANSMISSION GROUP (R30,175PSI,7.5HP)

Z2680

1	B80	V BELT	2
2	CC1016956	PULLEY,6.15 OD,SDS,2VA/B	1
3	P08632A	BUSHING,PULLEY,SDS,1-3/8	1

### TRANSMISSION GROUP (R30,125PSI,10HP)

Z3542

1	B81	V BELT	2
2	P11657A	PULLEY,8.35OD,SK,2VA/B	1
3	P05607A	BUSHING,PULLEY,SK,1-3/8	1

### TRANSMISSION GROUP (R30,175PSI,10HP)

Z2682

1	B81	BELT,V	2
2	CC1005979	PULLEY,7.75OD,SK,2VA/B	1
3	P05607A	BUSHING,PULLEY,SK,1-3/8	1

### TRANSMISSION GROUP (R30,125/175PSI,15HP)

Z6400

1	B85	BELT,V	2
2	VP1075873	PULLEY,11.15OD,SK,2VA/B	1
3	P05622A	BUSHING,PULLEY,SK,1-5/8	1

## Belt Guard – Standard

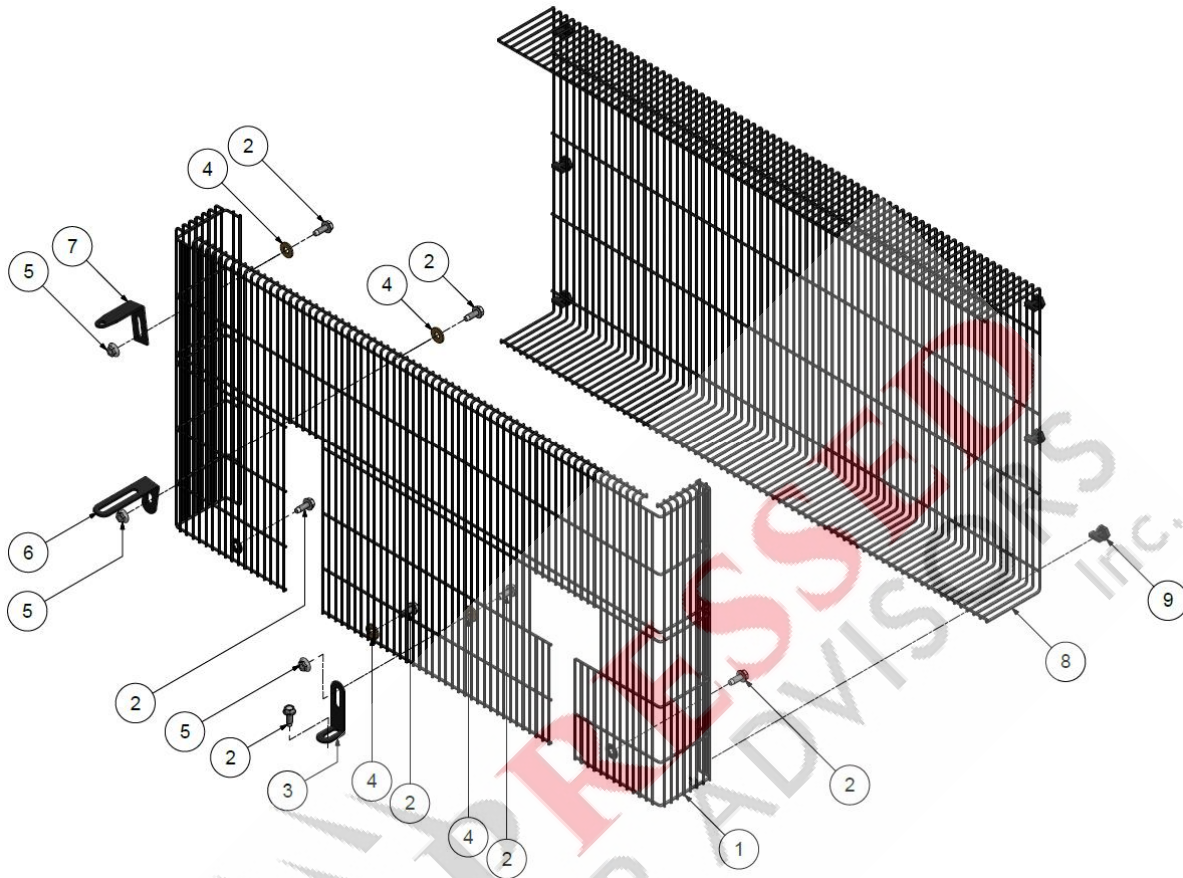

415CAS810-00  
Ref Drawing

### BELTGUARD - STANDARD

CC1066509

Part Number	Description	Quantity
1	CC1065309 BELTGUARD,BACK	1
2	M1454 SCREW	6
3	M1142 BRACKET	1
4	M3056 WASHER	4
5	M3485 NUT	3
6	M865 BRACKET	1
7	P14125B BRACKET	1
8	CC1065310 BELTGUARD,FRONT	1
9	P10005A CLIP	6

## Belt Guard – with Aftercooler (optional)

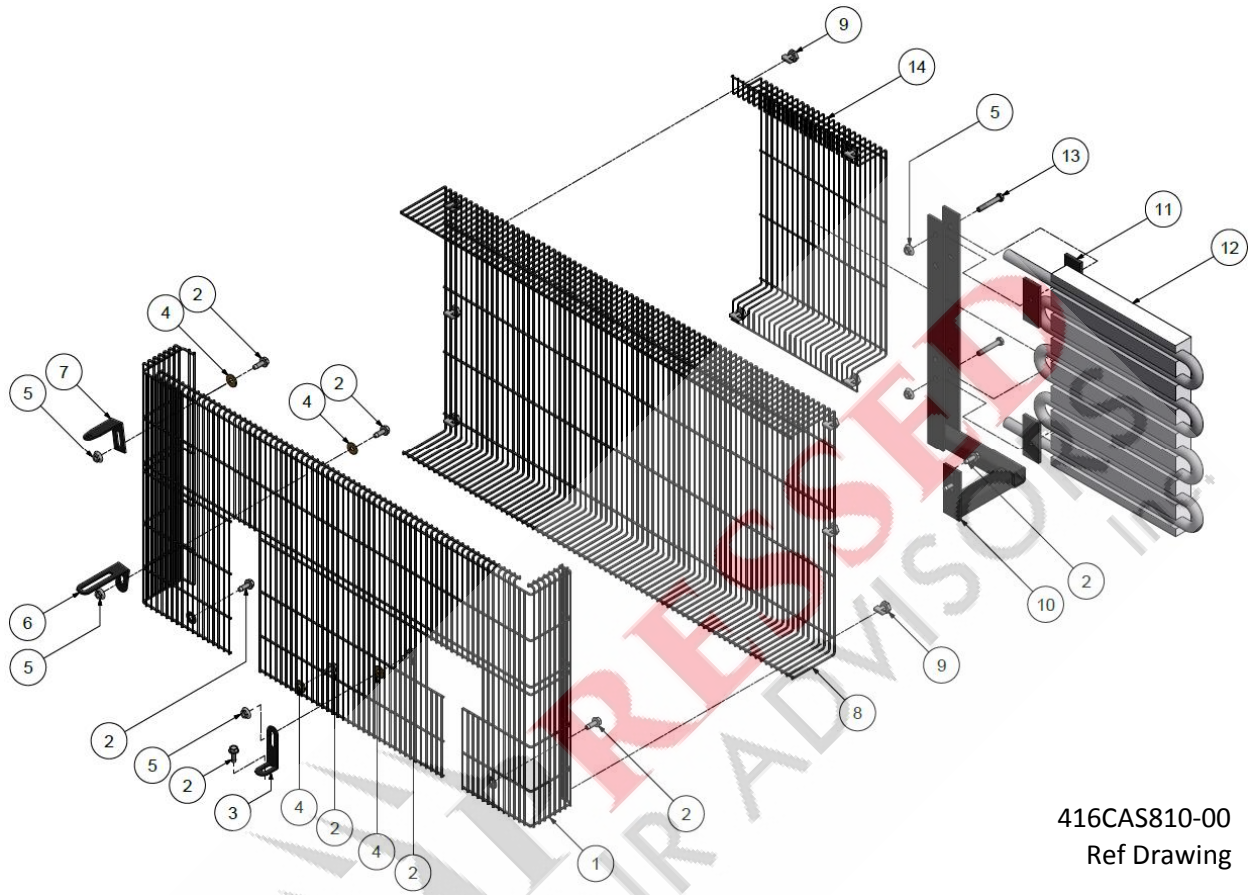

416CAS810-00  
Ref Drawing

### BELTGUARD - WITH AFTERCOOLER

**403CAS4029**

1	CC1065309	BELTGUARD,BACK	1
2	M1454	SCREW	9
3	M1142	BRACKET	1
4	M3056	WASHER	4
5	M3485	NUT	5
6	M865	BRACKET	1
7	P14125B	BRACKET	1
8	CC1065310	BELTGUARD,FRONT	1
9	P10005A	CLIP	10
10	CC1066742	BRACKET	1
11	M1367	ISOLATOR	4
12	CQP14773C	AFTERCOOLER	1
13	M2627	SCREW	2
14	P14071C	AFTERCOOLER GUARD	1

## Discharge Piping – Vertical, Standard

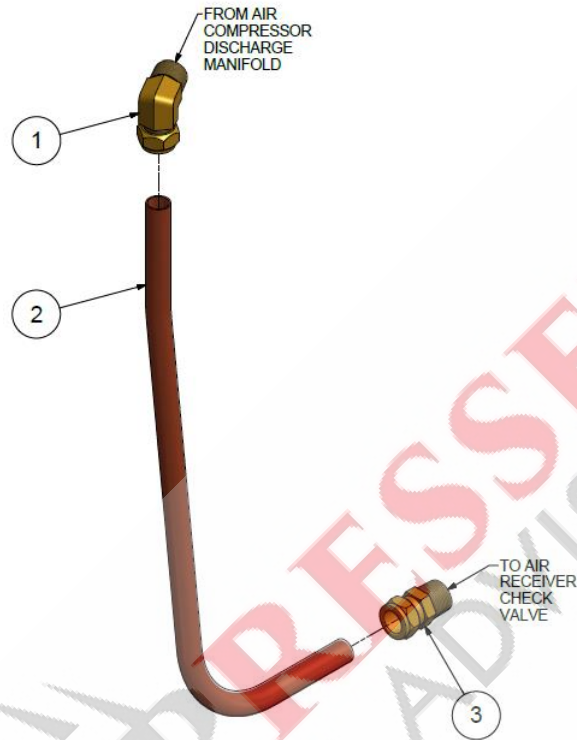

417CAS810-00  
Ref Drawing

### DISCHARGE PIPING - 80GL VERTICAL, STANDARD

411CAS4022

1	M2350	COMPRESSION FITTING, ELBOW	1
2	TEN010242	DISCHARGE TUBE	1
3	M2867	COMPRESSION FITTING, STRAIGHT	1

### DISCHARGE PIPING - 120GL VERTICAL, STANDARD

408CAS4022

1	M2350	COMPRESSION FITTING, ELBOW	1
2	TEN010243	DISCHARGE TUBE	1
3	M2867	COMPRESSION FITTING, STRAIGHT	1

## Discharge Piping – Vertical, with Aftercooler (optional)

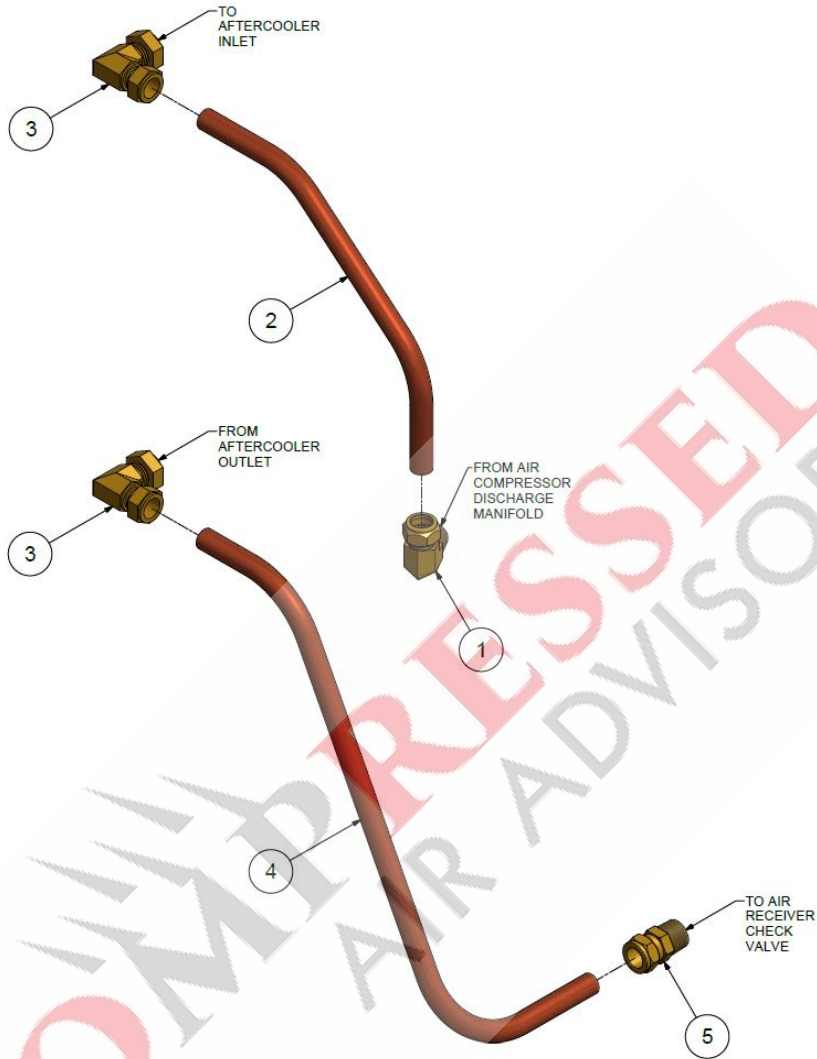

418CAS810-00  
Ref Drawing

### DISCHARGE PIPING - 80GL VERTICAL, AFTERCOOLER

405CAS4022

1	M2350	COMPRESSION FITTING, ELBOW	1
2	TEN010891	DISCHARGE TUBE, TO AFTERCOOLER	1
3	M2288	COMPRESSION FITTING, ELBOW	2
4	TEN009152	DISCHARGE TUBE, FROM AFTERCOOLER	1
5	M2867	COMPRESSION FITTING, STRAIGHT	1

### DISCHARGE PIPING - 120GL VERTICAL, AFTERCOOLER

402CAS4022

1	M2350	COMPRESSION FITTING, ELBOW	1
2	TEN010891	DISCHARGE TUBE, TO AFTERCOOLER	1
3	M2288	COMPRESSION FITTING, ELBOW	2
4	TEN009113	DISCHARGE TUBE, FROM AFTERCOOLER	1
5	M2867	COMPRESSION FITTING, STRAIGHT	1

## Discharge Piping – Horizontal, Standard

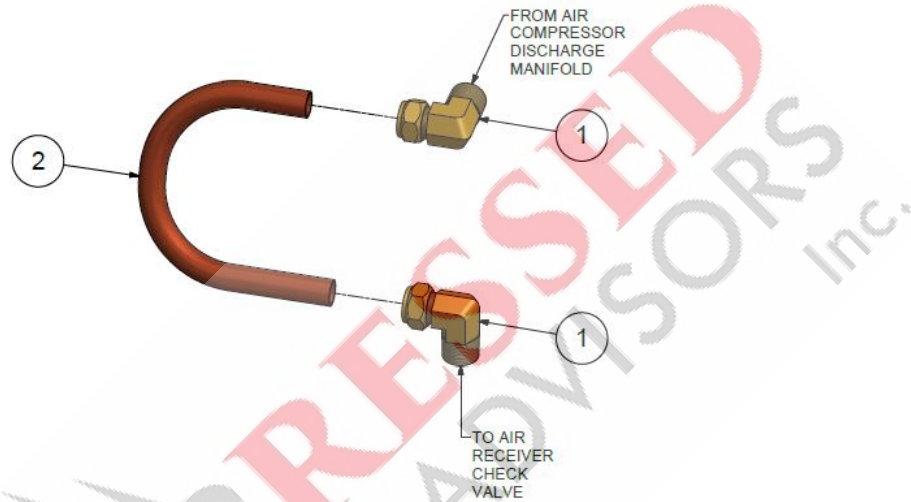

419CAS810-00  
Ref Drawing

### DISCHARGE PIPING - 80/120/240GL HORIZONTAL, STANDARD

412CAS4022

1	M2350	COMPRESSION FITTING, ELBOW	2
2	TEN010237	DISCHARGE TUBE	1



## Discharge Piping – Horizontal, with Aftercooler (optional)

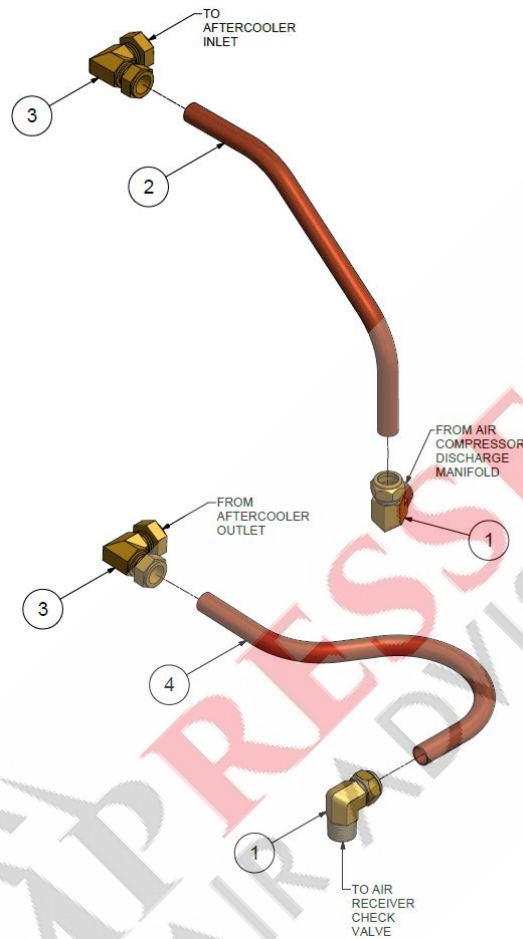

420CAS810-00  
Ref Drawing

### DISCHARGE PIPING - 80/120/240GL HORIZONTAL, AFTERCOOLER

406CAS4022

1	M2350	COMPRESSION FITTING, ELBOW	2
2	TEN010891	DISCHARGE TUBE, TO AFTERCOOLER	1
3	M2288	COMPRESSION FITTING, ELBOW	2
4	TEN009325	DISCHARGE TUBE, FROM AFTERCOOLER	1

### DISCHARGE PIPING - BASE MOUNT, AFTERCOOLER

425CAS4022

1	M2350	COMPRESSION FITTING, ELBOW	1
2	TEN010891	DISCHARGE TUBE, TO AFTERCOOLER	1
3	M2288	COMPRESSION FITTING, ELBOW	2
4	M2474 (NOT SHOWN)	COPPER TUBING	1.25
5	M2867 (NOT SHOWN)	COMPRESSION FITTING, STRAIGHT	1
6	M3424 (NOT SHOWN)	NUT	2
7	M3471 (NOT SHOWN)	SCREW	2
8	CC1032600 (NOT SHOWN)	COUPLING BRACKET	1





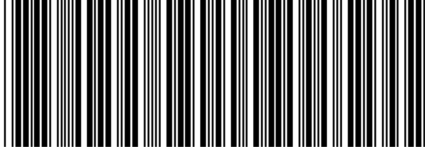

\* C Q F 3 4 5 5 V E R 0 1 \*  
\*CQF3455VER01\*

**COMPRESSED**  
AIR ADVISORS  
Inc.

**COMPRESSED**  
AIR ADVISORS

Inc.

**Compressed Air Advisors, Inc.**

Phone: 877.247.2381

[info@compressedairadvisors.com](mailto:info@compressedairadvisors.com)

[www.compressedairadvisors.com](http://www.compressedairadvisors.com)



Please recycle after use.