

THE FOLLOWING USER MANUAL APPLIES TO THE TSUNAMI PART NUMBERS SHOWN BELOW

10Hp Regenerative Dryer (Float Drains)
PN: 21999-1010

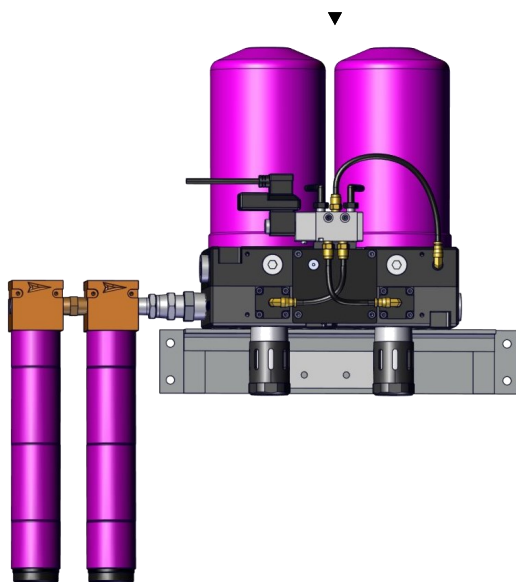

10Hp Regenerative Dryer (Pneumatic Drains)
PN: 21999-1010-MM

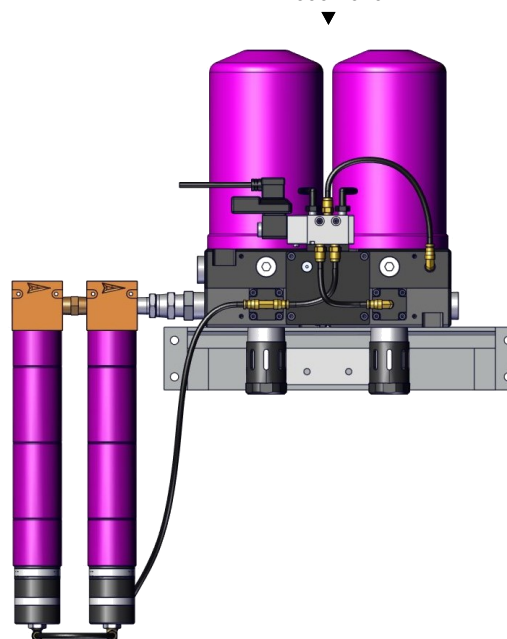

User Manual: Tsunami Regenerative Dryers



WARNING

Your safety is very important. Read all instructions before beginning any service or installation on your Tsunami Regenerative Dryer. Always wear safety eye protection when working with compressed air products. Failure to follow maintenance instructions could result in operating failure or product damage. System pressure must be released prior to any installation or service. Always install the system with the arrows indicating the direction of airflow. Use appropriate thread sealant on all connection fittings unless otherwise specified. Do not alter the filtration system from its original design as this may cause failure in its operation parameters.

DESCRIPTION

Congratulations on the purchase of your Tsunami Regenerative Drying System! By adhering to the specifications and maintenance schedule listed in the manual, your air system will provide years of service with minimal maintenance.

Incoming air enters the 1st stage water separator where water and particulates are removed down to 10 micron. The air then travels through the 2nd stage oil coalescing filter where oil aerosols are filtered down to .001 ppm and particulates are trapped down to .01 micron. The pretreated air enters the regenerative dryer where molecular sieve desiccant captures water vapor. Approximately every 90 seconds, the timer sends out a signal causing an internal piston to shift. The shift in the piston redirects air flow through the opposite dryer canister. This Tsunami Regenerative Drying System can provide dew points down to -80°F and relative humidity down to .01% RH. All dryers come standard with automatic drains to assume proper disposal of all contaminants captured in the water separator and oil coalescing filter.

DRYER SPECIFICATIONS

Maximum Inlet Air Temperature: 150°F
Maximum Pressure: 175 psi
Maximum Flow: 40 SCFM
Inlet Port: 1/2" NPT
Outlet Port: 1" NPT

INSTALLATION & SERVICE REQUIREMENTS

IMPORTANT: Tsunami Regenerative Dryers are configurable in multiple variations. Before beginning installation it is important to determine the direction of air flow which best meets your installation application requirements. Failure to follow mandatory maintenance schedule will void warranty.

Dryer Installation & Configuration	pg. 2
Mandatory 6 Month Service	pg. 3
• Oil Coalescing Filter Element Replacement (P/N: 21999-0202)	
Recommended 6 Month Service	pg. 3
• Lubrication of piston spool and piston bore (P/N: 21999-0202)	
Recommended Annual Service	pg. 3
• Replacement of piston spool and piston bore (P/N: 21999-0707)	
Recommended 3 Year Service	pg. 4
• Replacement of dryer canisters (P/N: 21999-0349)	
Troubleshooting Guide	pg. 4

INSTALLATION INSTRUCTIONS - BYPASS CIRCUIT INSTALL

For ease of service, it is highly recommended to install a bypass circuit around the regenerative dryer. Follow the diagram below when installing a bypass circuit. Verify that system pressure is relieved prior to performing installation.

A. Inlet Ball Valve B. Bypass Ball Valve C. Outlet Ball Valve

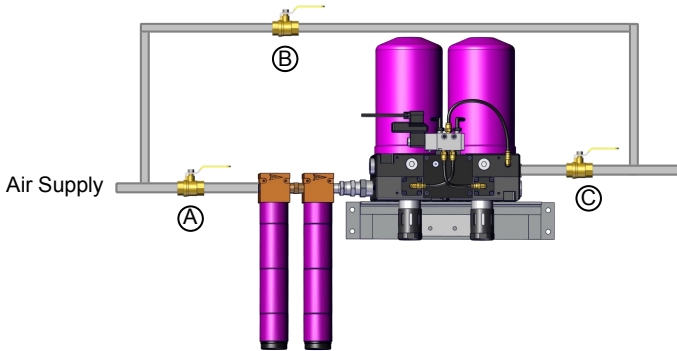

Using the dryer: Open the inlet and outlet ball valves and close the bypass valve to direct air flow through the regenerative dryer. This will provide clean, dry air downstream.

Bypassing the dryer: Close the inlet and outlet ball valves and open the bypass valve to direct airflow around the dryer. This will allow service or maintenance to be performed without shutting down total compressed air supply.

INSTALLATION INSTRUCTIONS - DRYER INSTALLTION

IMPORTANT: Tsunami Regenerative Dryers are configurable in multiple variations. Before beginning installation it is important to determine the direction of air flow which best meets your installation application requirements.

All dryers contained in this manual follow the same installation procedures.

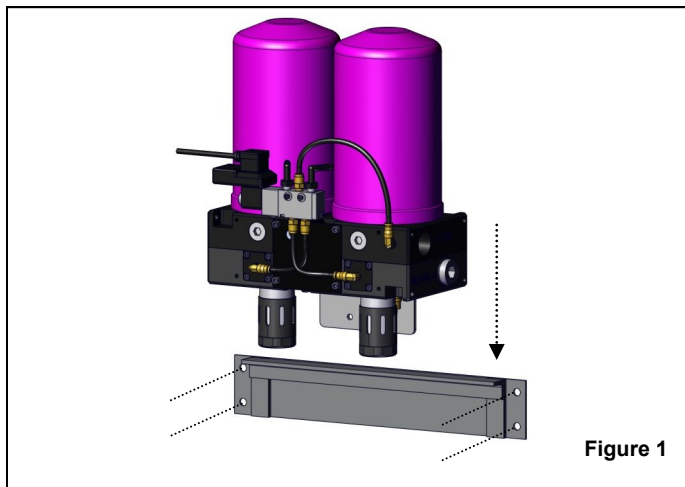

Figure 1

1. Remove all system pressure.
2. Using the appropriate hardware (not included), mount dryer bracket to wall. *Figure 1*
3. Once the wall bracket has been properly secured to the wall, place the dryer mounting rail into the slot(s) of the wall bracket. *Figure 1*

INSTALLATION INSTRUCTIONS - DRYER INSTALLTION cont.

4. Install the supplied FEMALE JIC fitting to outlet port of the Tsunami pre-filter assembly. Use appropriate thread sealant. *Figure 2*
5. Determine preferred direction of flow. **IMPORTANT: Air must travel through the Tsunami filters prior to entering the regenerative dryer.**
6. Using the appropriate thread sealant, install the MALE JIC connector to either the left or right INLET / AUX port of the dryer. *Figure 2*

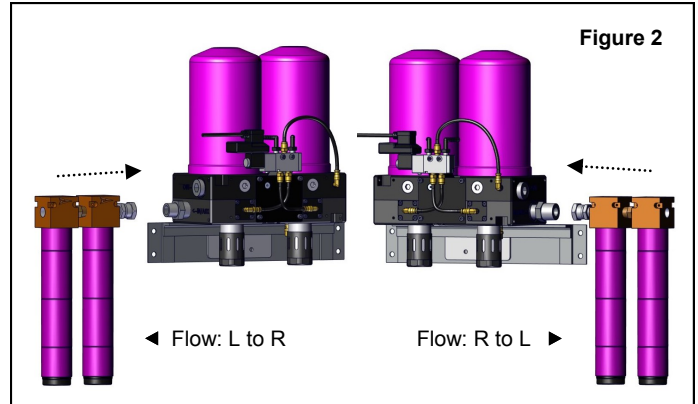

Figure 2

7. Using an adjustable or 5/8" wrench, plug the remaining open ports with the provided 1" port plugs and large hex tool. Use appropriate thread sealant.
8. Attach the filter assembly to the dryer housing by connecting the MALE and FEMALE JIC fittings. Tighten firmly.
9. (21999-1010-MM MODELS ONLY) Use provided black nylon tubing to connect Moisture Minder® Filter Drains to "T" fitting located on dryer housing. Excess tubing can be cut to length. *Figure 3*

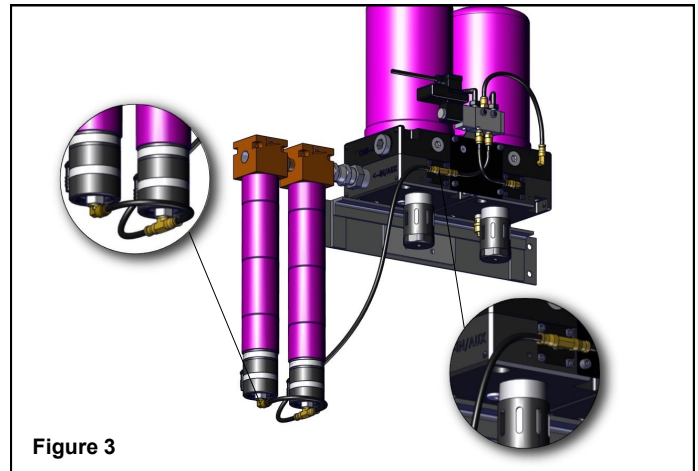

Figure 3

10. Attach 3/8" clear plastic tubing to the bottom of the Float Drains or Moisture Minder® Filter Drains. Follow all local and state regulations when routing the drain lines.
11. For 110v dryers, plug unit into wall.
12. For 220v dryers, install a 220/230/240 single phase plug on flying leads and plug into appropriate outlet or hardwire into gauge box. Make sure all local electrical codes are followed and that work is performed by a qualified representative.

MAINTENANCE INSTRUCTIONS - COALESCING ELEMENT

Mandatory every 6 months

- Oil Coalescing Filter Element Replacement (P/N: 21999-0202)

Your safety is very important. Read all instructions before beginning any service or installation on your Tsunami Regenerative Dryer. Always wear safety eye protection when working with compressed air products. Failure to follow maintenance instructions could result in operating failure or product damage. System pressure must be released prior to any installation or service.

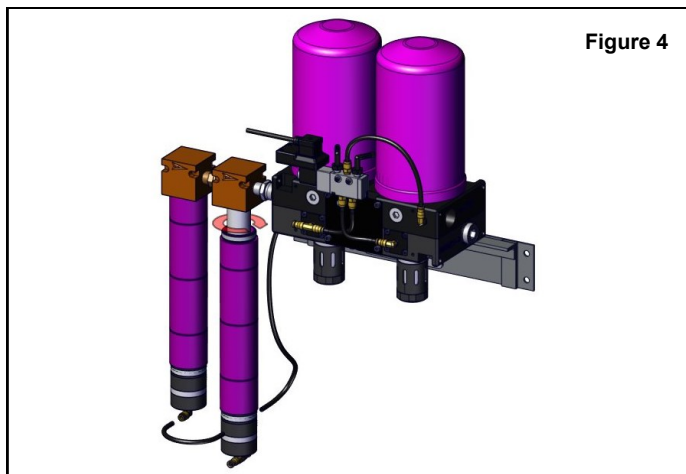

Figure 4

1. Unplug unit from power source.
2. Release all system pressure.
3. (21999-1010-MM MODELS ONLY) Disconnect the pilot line located at the bottom of the oil coalescing filter.
4. Remove filter tube from filter head by holding filter head and rotating tube counter-clockwise.
5. Using a 5/16" wrench, remove baffle nut from threaded rod below element.
6. Remove bottom baffle, filter element, top adaptor, and O-ring. *Figure 5*

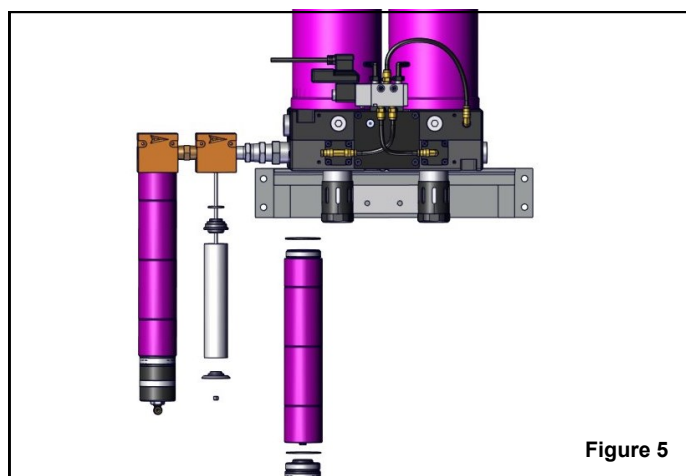

Figure 5

5. Replace filter element and hardware in reverse order from previous steps. Tighten baffle nut until filter element can no longer spin freely. **DO NOT OVER TIGHTEN NUT!**
6. Reinstall outer tube by rotating clockwise onto filter head.
7. (21999-1010-MM MODELS ONLY) Reconnect pilot tubing and plug unit back into wall.
8. Slowly pressurize the unit.

MAINTENANCE INSTRUCTIONS - PISTON LUBRICATION

Recommended every 6 months

- Lubrication of piston spool and piston bore (21999-0202)

Recommended annually

- Piston Replacement Kit (21999-0707)

Your safety is very important. Read all instructions before beginning any service or installation on your Tsunami Regenerative Dryer. Always wear safety eye protection when working with compressed air products. Failure to follow maintenance instructions could result in operating failure or product damage. System pressure must be released prior to any installation or service.

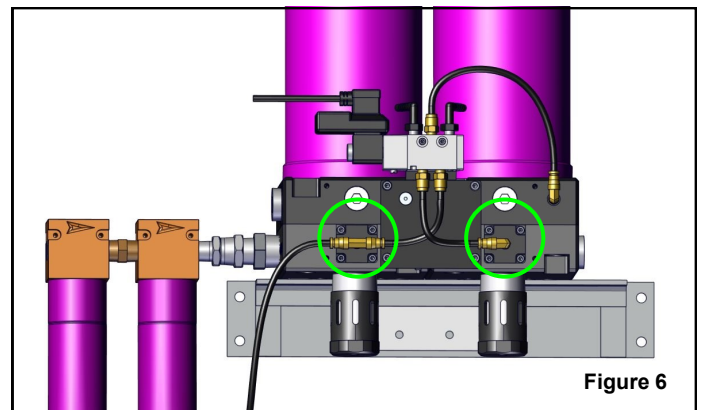

Figure 6

Note: Each canister contains one piston.

1. Unplug unit from power source.
2. Release all system pressure.
3. Disconnect tubing from quick-connect fitting located on piston cover. Push in on brass ring. While holding ring in, pull out tubing. *Figure 6*
4. Using a 4mm hex key wrench, remove the four socket head cap screws holding the piston cover in place. *Figure 7*
5. Remove piston cover for access to piston.
6. Using a finger or a 1/2-13 bolt, remove the piston from the piston bore. Be sure to remove the piston spring. *Figure 7*
7. Using dielectric grease, lubricate the piston bore. Grease thoroughly.
8. Lubricate the top three O-rings located on the piston.

Note: It is unnecessary to grease bottom O-ring (small diameter).

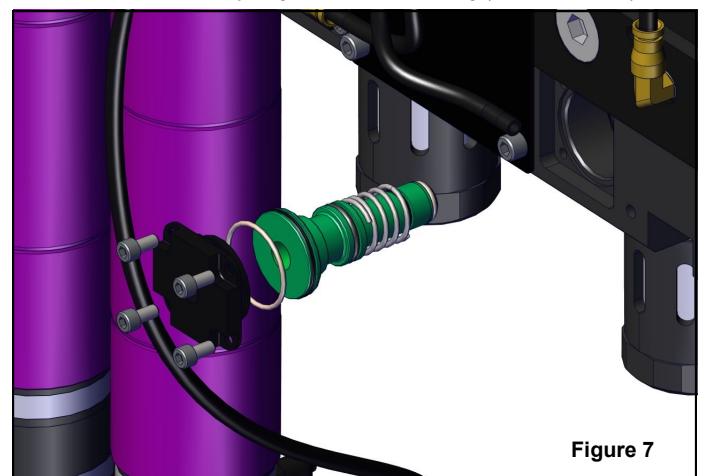

Figure 7

9. Place spring back onto piston.
10. Carefully insert piston back into piston bore. Press until piston is fully seated.
11. Replace piston cover for access to piston.
12. Using a 4mm hex key wrench, replace the four socket head cap screws holding the piston cover in place. Tighten until snug, then add 1/4 turn. *Figure 7*
13. Reconnect tubing to quick-connect fitting located on piston cover. *Figure 7*
14. Slowly pressurize the unit.

SERVICE INSTRUCTIONS - DRYER CANISTER REPLACEMENT

Recommended 3 Year Service

- Replacement of dryer canisters (P/N: 21999-0349)

Your safety is very important. Read all instructions before beginning any service or installation on your Tsunami Regenerative Dryer. Always wear safety eye protection when working with compressed air products. Failure to follow maintenance instructions could result in operating failure or product damage. System pressure must be released prior to any installation or service.

1. Unplug unit from power source.
2. Release all system pressure.
3. Using a strap wrench (if necessary), unscrew each canister from the top of the dryer housing. Discard.
4. Remove and discard small O-ring from dryer mounting stud.
5. Remove and discard large gasket from canister housing.
6. Clean top surface of dryer housing and mounting stud.
7. Using the supplied grease, apply light coating to the new O-ring. Install O-ring onto mounting stud. *Figure 9*
8. Apply a light amount of the supplied grease to the new canister gasket. *Figure 9*

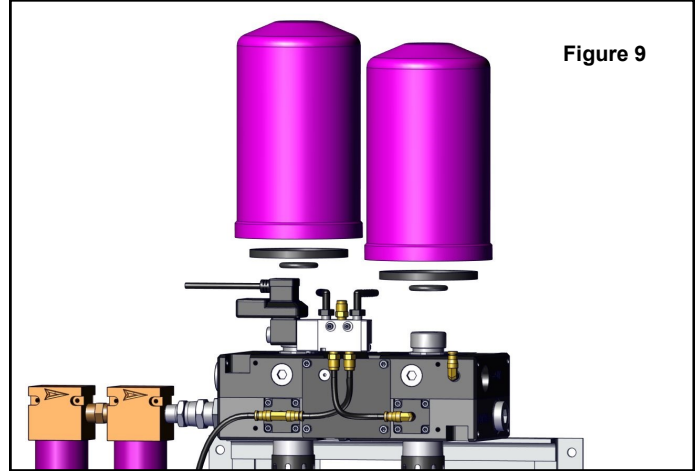
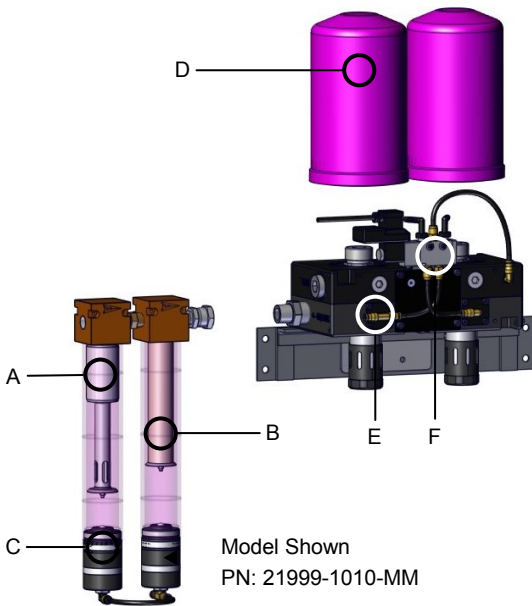

Figure 9

9. Thread new canister onto the mounting stud. Once gasket contacts adaptor plate, tighten canister 1/2 turn. DO NOT OVERTIGHTEN.

TROUBLESHOOTING GUIDE - TSUNAMI REGENERATIVE DRYER



Model Shown
PN: 21999-1010-MM

- A** Water Separator
Service Kit PN: 21999-0227
- B** Oil Coalescing Element
Replacement PN: 21999-0202
- C** 21999-1010-MM MODEL
Moisture Minder® Filter Drains
Replacement PN: 21999-0795
21999-1010 MODEL (not pictured)
Automatic Float Drains
Replacement PN: 21999-0868
- D** Dryer Desiccant Canister
Replacement PN: 21999-0349
- E** Piston
Replacement PN: 21999-0707
- F** Solenoid Timer Valve
Replacement PN: 21999-0941

PROBLEM	PROBABLE CAUSE	CORRECTION
Water / Oil Carryover	A. Water Separator not properly draining B. Moisture Minder® Drain not working C. Coalescing filter element cracked or saturated D. Desiccant tower saturated or oil carryover has gotten on the media E. Over flowing dryer F. Dryer not sized properly	a. Remove and verify automatic drains are functioning. b. Check to see if Moisture Minder® is dispersing water. If not, replace. c. Replace coalescing filter element. See Maintenance Instructions Page 3. d. Replace desiccant canister. See Service Instructions Page 4. e. Reduce the SCFM being used downstream of dryer. Contact Distributor. f. Contact your distributor for more info.
Excess Air Purging Out Muffler	A. Piston stuck	a. Grease or replace piston. See Maintenance Instructions Page 3.
Dryer Not Cycling	A. Power cord damaged B. Solenoid Timer Valve not properly working	a. Replace power cord. Contact your distributor for more information. b. Replace solenoid timer valve.