

ZONE		REV	DESCRIPTION	DATE	DWN	CHK
		B	REDRAWN AND REVISED: ECN 1074407	3-14-13	KWT	DA

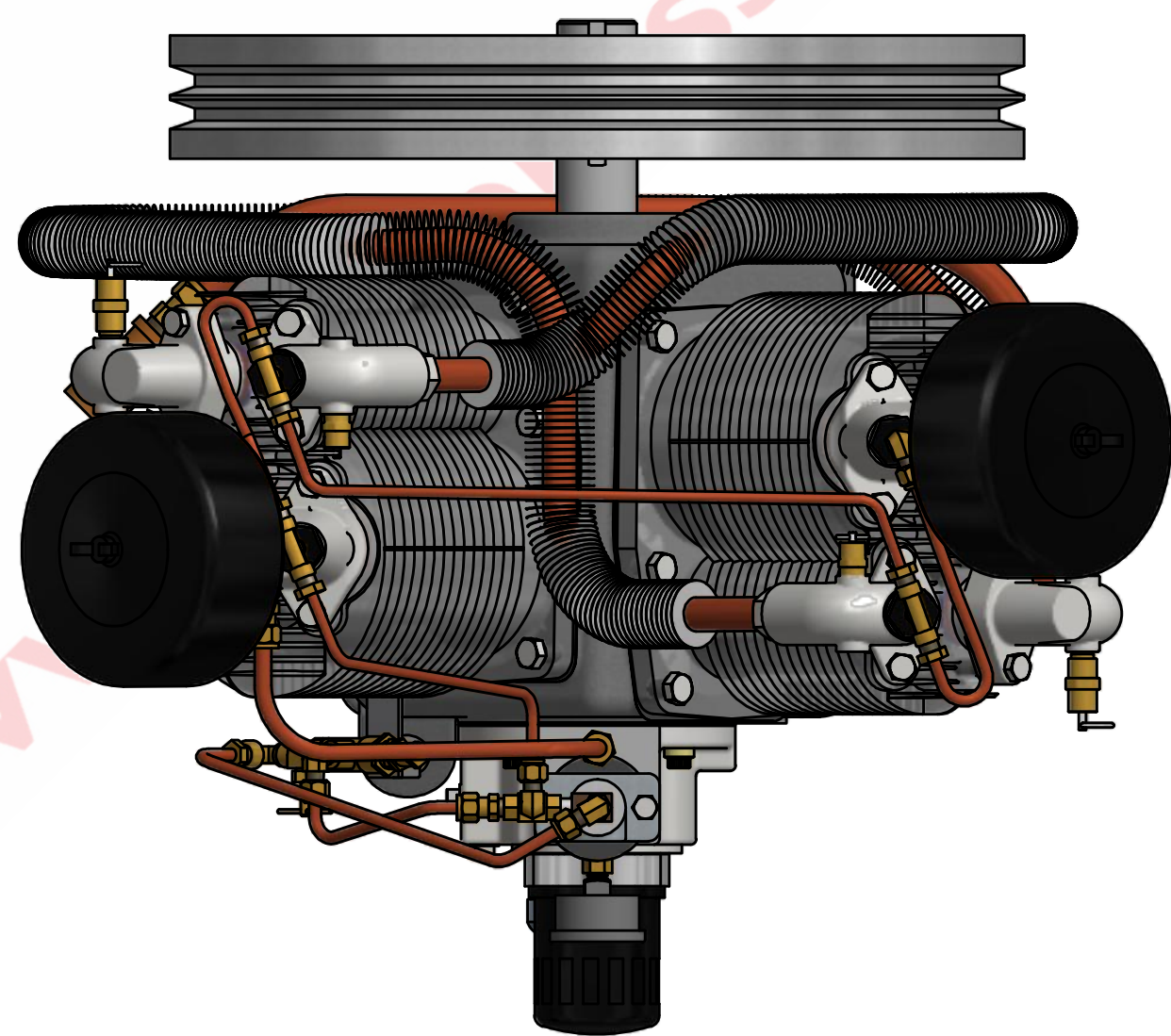
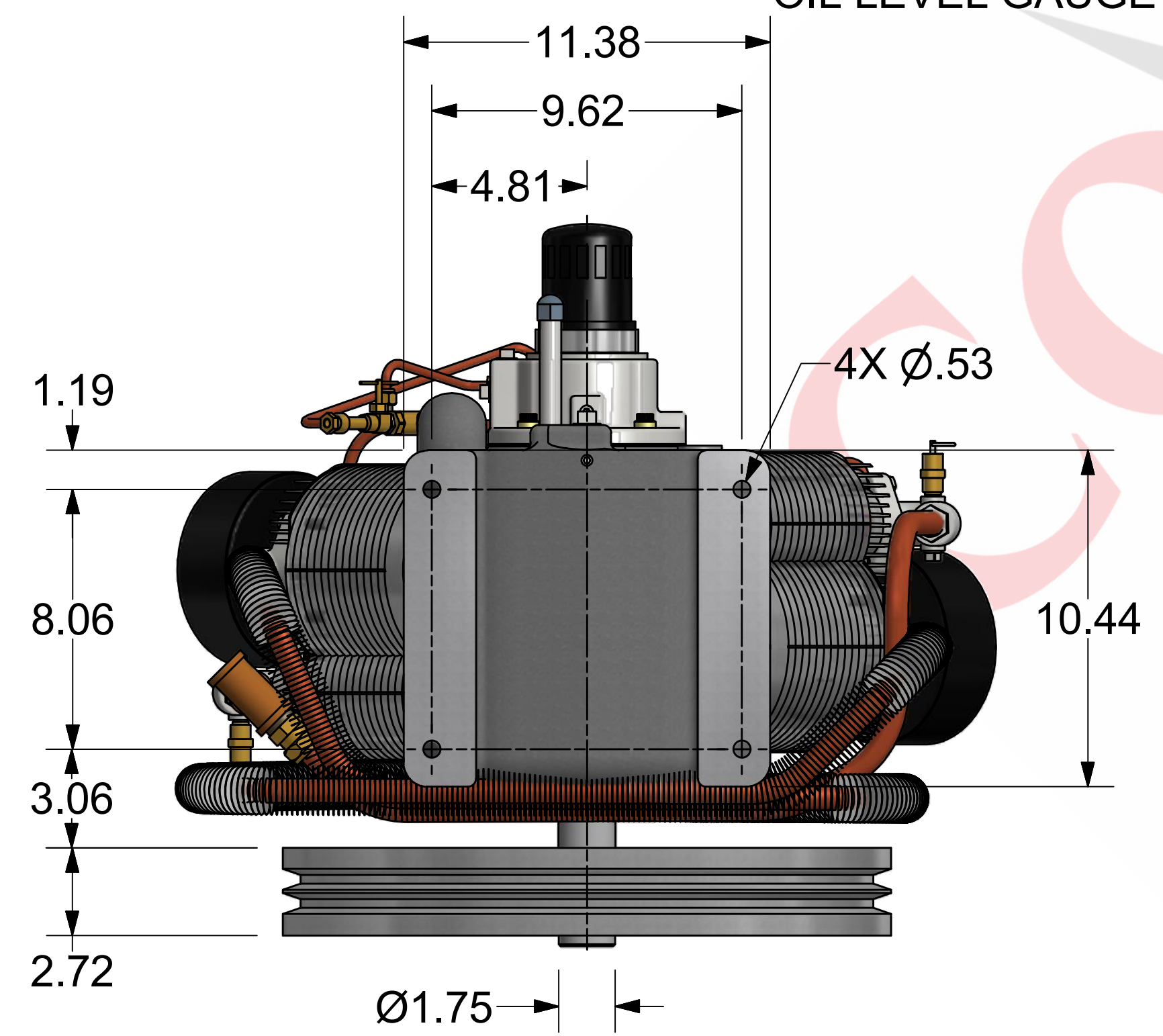
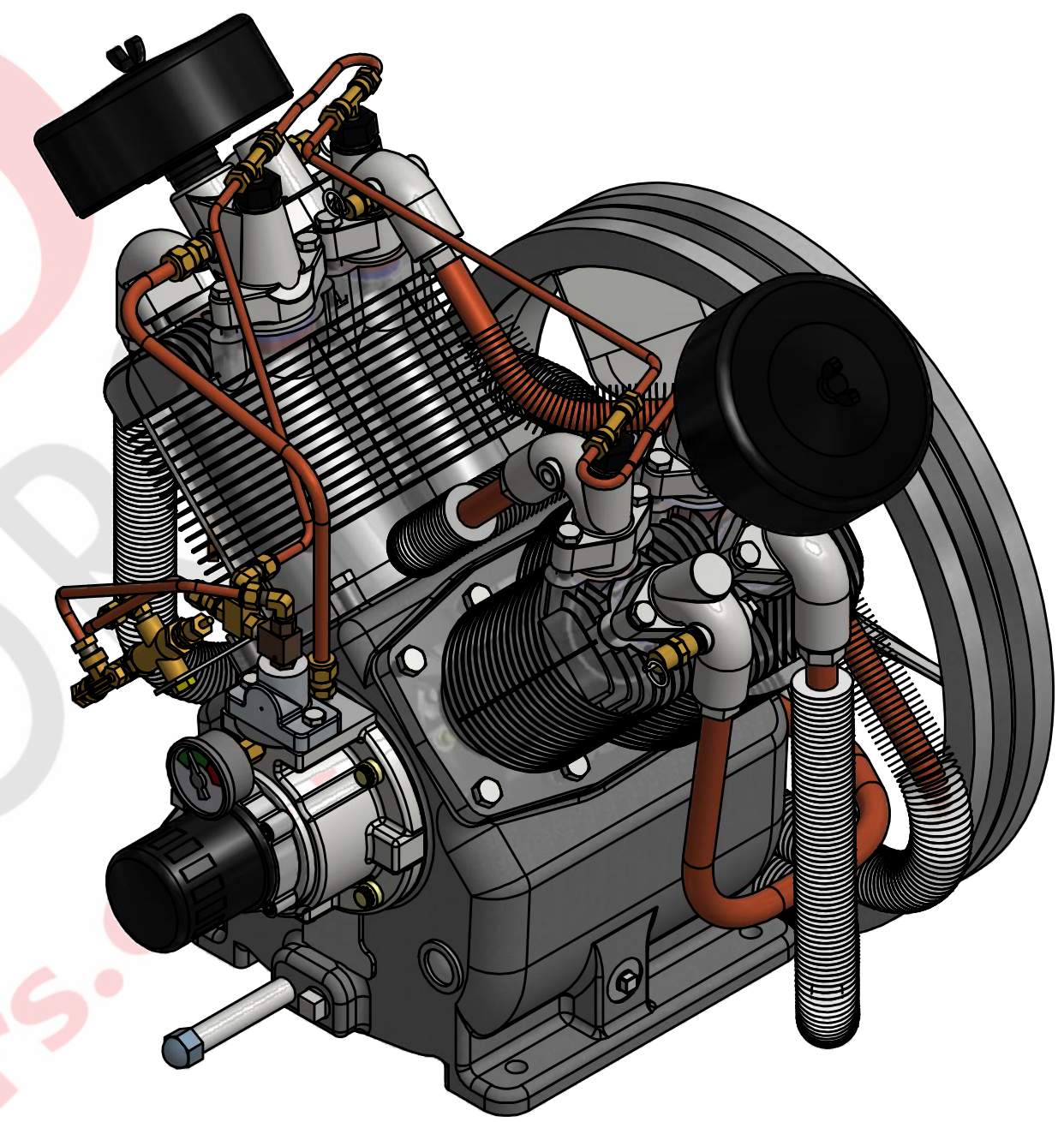
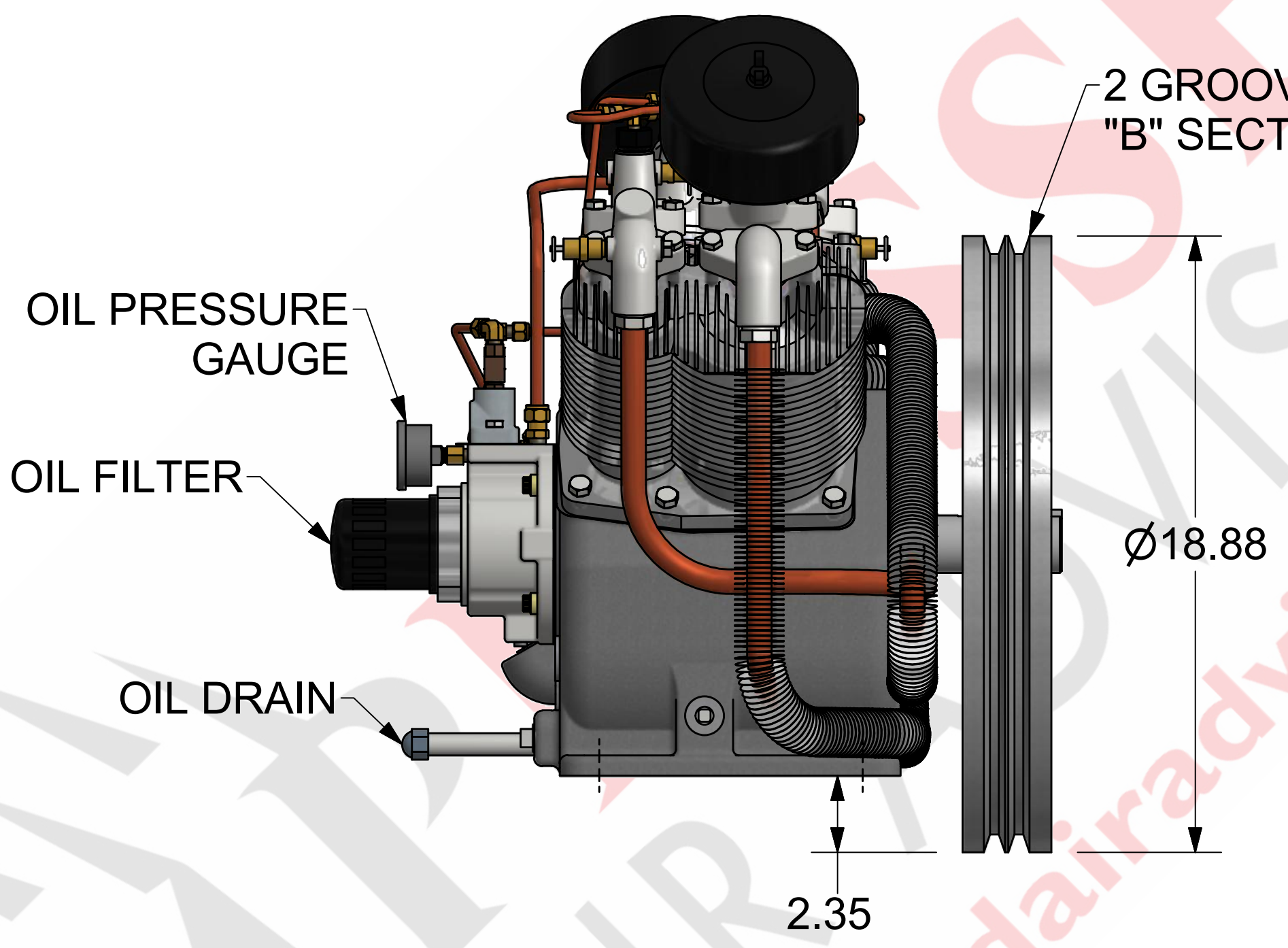
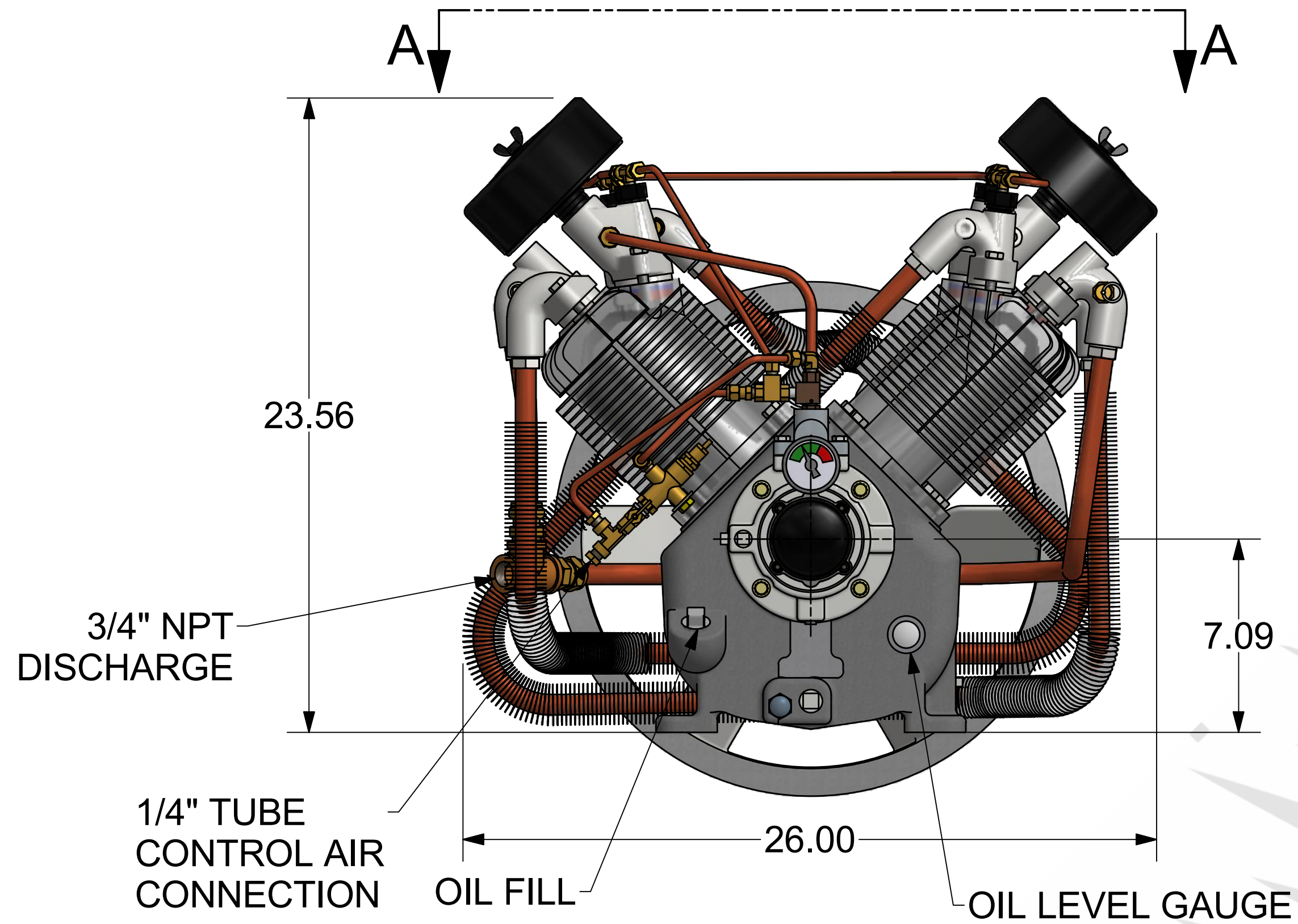

VIEW A-A  
SCALE 1 / 4

**COMPRESSED**  
AIR ADVISORS  
Inc.  
Compressed Air Advisors, Inc.  
Phone: 877.247.2381  
info@compressedairadvisors.com  
www.compressedairadvisors.com

- NOTES:
- DO NOT SCALE PRINT, TYPICAL DIMENSIONS ONLY.
  - SPECIFICATIONS AND DIMENSIONS ARE SUBJECT TO CHANGE WITHOUT NOTICE OR OBLIGATION.
  - ALL DIMENSIONS IN INCHES.
  - CLOCKWISE ROTATION WHEN VIEWED FROM FRONT, FLYWHEEL IN REAR.

FINISH OF CHAMFERS AND FILLETS TO CONFORM TO ROUGHEST ADJACENT AREA. SURFACE ROUGHNESS MAXIMUM PER ASME B46.1. FULL THREAD DEPTHS ARE MINIMUM.		CONFIDENTIAL - THE INFORMATION CONTAINED IN THIS DOCUMENT IS THE PROPERTY OF GARDNER DENVER, INC. IT IS NOT FOR PUBLIC DISCLOSURE. POSSESSION OF THE INFORMATION DOES NOT CONVEY ANY RIGHT TO LOAN, SELL OR DISCLOSE THE INFORMATION. UNAUTHORIZED REPRODUCTION OR USE OF THE INFORMATION IS PROHIBITED. THIS DOCUMENT IS TO BE RETURNED TO GARDNER DENVER, INC. UPON THE COMPLETION OF THE PURPOSE FOR WHICH IT IS LOANED OR UPON REQUEST.	
UNLESS OTHERWISE SPECIFIED DIMENSIONS ARE IN INCHES		DIMENSIONING AND TOLERANCING PER ASME Y14.5-2009 THREADS PER ASME B1.1 GAGING SYSTEM 21 U.O.S., ANSI B1.20.1 & B1.20.3	
TOL. ON DECIMALS: .X = ± .05 TOL. ON DECIMALS: .XX = ± .02 TOL. ON DECIMALS: .XXX = ± AS SPECIFIED TOL. ON ANGLES: ± 0°-30'		HEAT TREATMENT	ENG. REF:
THIRD ANGLE PROJECTION		TITLE UNIT MODEL PL30A PUMP	
Gardner Denver Inc. Quincy, IL.		SIZE D	ENG. APPROVAL DA
DWN BY MDH 12/11/1996		DWG NO. DD-1268	REV A
CKD BY DA 3/14/2013		SCALE 1/2	SHEET 1 OF 1