

SEPREMIUM 750

Oil /water separator

COMPRESSED
AIR ADVISORS
Inc.



7/18

GENERAL OPERATION

The SEP750 range of oil/water separators separates oil from condensate, generated by compressed air systems. The SEP750 achieves separation of oil from condensate by means of directing the condensate through various separation stages.

As condensate flows in to the SEP750, the oil is filtered out through various filtration elements.

The first oil adsorbing element has a clever saturation indicating feature, offering you a visual operating status of the separator at a distance.

The elements are designed to combine various types of adsorption technologies to achieve less than 10 ppm oil residue values at the output stage.

Final separation stage includes specially selected activated carbon to polish out the remaining contaminants.

SAFETY INSTRUCTIONS

SAFETY AND PROPER USAGE

To ensure safe and enduring performance of this product, you must comply strictly with the instructions enclosed herein. Non-compliance with instructions or improper handling of the product will void your warranty! Usage of this product in conditions not specified in this manual or in contrary to the instructions hereby provided is considered IMPROPER. The manufacturer will not be held liable for any damages resulting from improper use of the product.

SAFETY & WARNING INSTRUCTIONS

ATTENTION

- Observe valid and generally accepted safety rules when planning, installing and using this product.
- Take proper measures to prevent unintentional operation of the product or damage to it.
- Do not attempt to disassemble this product or lines in the system while they are under pressure.
- Always depressurise the compressed air system before working on the system.

It is important that personnel use safe working practices and observe all regulations and legal requirements for safety when operating this product. When handling, operating or carrying out maintenance on this product, personnel must employ safe engineering practices and observe all local health & safety requirements & regulations. International users refer to regulations that prevail within the country of installation. Most accidents, which occur during the operation and maintenance of machinery, are the result of failure to observe basic safety rules or precautions. An accident can often be avoided by recognising a situation that is potentially dangerous. Improper operation or maintenance of this product could be dangerous and result in an accident causing injury or death. The manufacturer cannot anticipate every possible circumstance, which may represent a potential hazard. The WARNINGS in this manual cover the most common potential hazards and are therefore not all-inclusive. If the user employs an operating procedure, an item of equipment or a method of working which is not specifically recommended by the manufacturer he must ensure that the product will not be damaged or made unsafe and that there is no risk to persons or property.



WARNING: This product can expose you to chemicals including lead, which is known to the State of California to cause cancer and/or birth defects or other reproductive harm. For more information, go to www.P65Warnings.ca.gov

EXPLODED VIEW AND IDENTIFY ALL COMPONENTS DIAGRAM

When White Rod sinks it is time to change bags.

Red Rod will be in down position unless there is an overflow condition.



INSTALLATION INSTRUCTIONS

IMPORTANT NOTICE

Before installing this product, make sure it complies with your request and that it suits your application!

1. Unpack the unit and visually inspect for any transport damage incurred after leaving our factory.

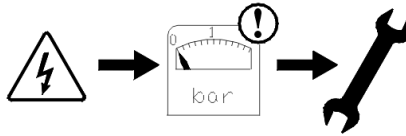

2. Depressurise the system before installation or maintenance is carried out!

3. Locate a suitable point on your compressor system to place your SEPREMIUM 750. This point must be near a suitable sewage point. The unit is designed to easily fit against a wall.

4. Remove both lids.

Condensate collection pipe

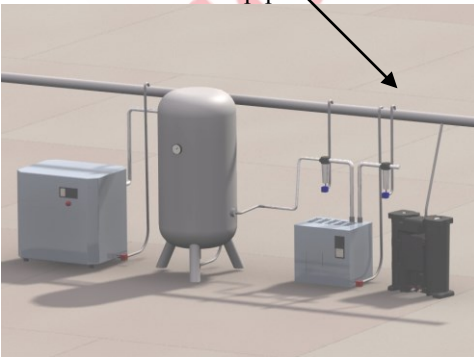

INSTALLATION INSTRUCTIONS

5. Remove the plastic bag which is placed on top of the static white element inside tower 2.



6. Remove both white elements.



7. Connect the condensate collection pipe to the inlet's from the SEPREMIUM 750.



8. Connect the outlet from the SEPREMIUM 750 to a suitable sewage point. Make sure the condensate always flows down.



9. Before filling the unit with water make sure that the test drain and service drains are closed.

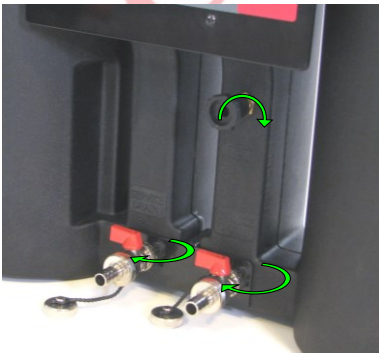

10. Fill the unit with water from tower 1 until both towers are filled and water flows out of the outlet point.



Tip: spraying water over the black element in tower 2 before filling the housing prevents carbon dust from spreading.

INSTALLATION INSTRUCTIONS

11. Make sure the black element rests on the bottom of the tower by pushing it down.



Push the element down until all the trapped air has escaped out of the carbon element.

12. When both towers are filled with water and the black element rests on the bottom of tower 2 you can replace both white elements. White indicator element in tower 1 and static white element in tower 2.



13. Replace both lids. (Lid 1 on tower 1 and lid 2 on tower 2). The static white element will be pushed in place by lid 2.

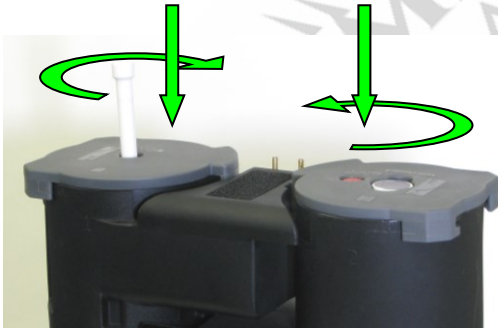

14. Your SEPREMIUM 750 is ready for operation.

Make sure both lids are placed and secured properly.

SERVICE INSTRUCTIONS

When your SEPREMIUM 750 requires maintenance (replacement of elements) please refer to our dedicated maintenance instructions (supplied with SEPREMIUM 750 element service kit).

SERVICE CHART

Date	Description	Name

TECHNICAL SPECIFICATIONS

Max. oil adsorption element's	Approx. 4 Gallons US (15 Liters)
Inlet connections	½" (2x)
Outlet connections	1"
Test valve	Yes
Service drains	Yes (2x)
Element life indicator	Yes
Overflow indicator	Yes
Housing material	PE
Total recyclable	Yes
Housing color	Black
Lid color	grey

Mineral lubricants	Yes
Synthetic lubricants	Yes
Stabile condensate emulsions	Yes
Polyglycol	Yes (consult factory)
Max. compressor capacity	750 cfm (20 m ³ /min) (based on a 8h. shift)

DIMENSIONS

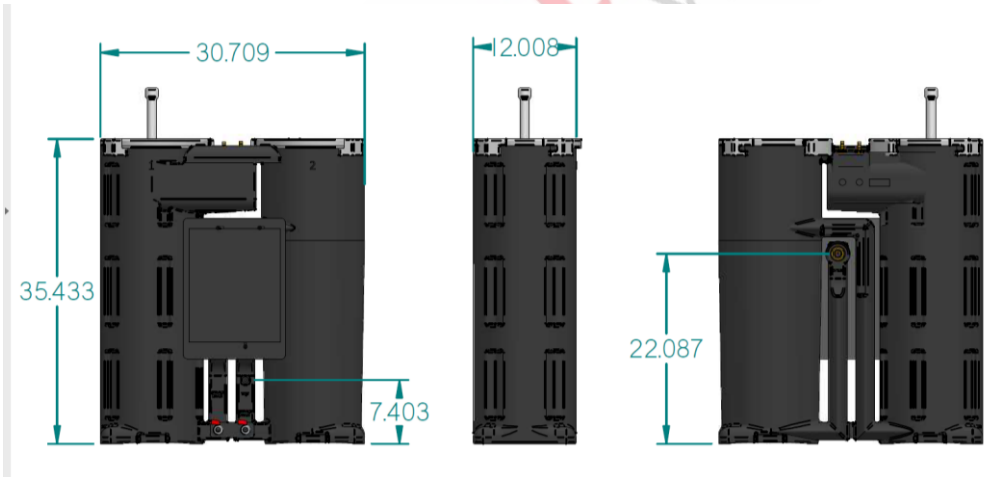

COMPRESSED
AIR ADVISORS

Inc.

Compressed Air Advisors, Inc.

Phone: 877.247.2381

info@compressedairadvisors.com

www.compressedairadvisors.com