

COMPRESSED
AIR ADVISORS
Inc.

COMPRESSED
AIR ADVISORS
Inc.

Compressed Air Advisors, Inc.

Phone: 877.247.2381

info@compressedairadvisors.com

www.compressedairadvisors.com



INSTALLATION INSTRUCTIONS

07-2018

SAFETY AND PROPER USAGE

To ensure safe and enduring performance of this product, you must comply strictly with the instructions enclosed herein. Non-compliance with instructions or improper handling of the product will void your warranty! Usage of this product in conditions not specified in this manual or in contrary to the instructions hereby provided is considered IMPROPER. The manufacturer will not be held liable for any damages resulting from improper use of the product.

SAFETY & WARNING INSTRUCTIONS

- Observe valid and generally accepted safety rules when planning, installing and using this product.
- Take proper measures to prevent unintentional operation of the product or damage to it.
- Do not attempt to disassemble this product or lines in the system while they are under pressure.
- Always depressurise the compressed air system before working on the system.

It is important that personnel use safe working practices and observe all regulations and legal requirements for safety when operating this product. When handling, operating or carrying out maintenance on this product, personnel must employ safe engineering practices and observe all local health & safety requirements & regulations. International users refer to regulations that prevail within the country of installation. Most accidents, which occur during the operation and maintenance of machinery, are the result of failure to observe basic safety rules or precautions. An accident can often be avoided by recognising a situation that is potentially dangerous. Improper operation or maintenance of this product could be dangerous and result in an accident causing injury or death. The manufacturer cannot anticipate every possible circumstance, which may represent a potential hazard. The WARNINGS in this manual cover the most common potential hazards and are therefore not all-inclusive. If the user employs an operating procedure, an item of equipment or a method of working which is not specifically recommended by the manufacturer he must ensure that the product will not be damaged or made unsafe and that there is no risk to persons or property.

NEVER CHANGE ORIGINAL COMPONENTS WITH ALTERNATIVES



WARNING: This product can expose you to chemicals including lead, which is known to the State of California to cause cancer and/or birth defects or other reproductive harm. For more information, go to www.P65Warnings.ca.gov

INSTALLATION INSTRUCTIONS

Before installing this product, make sure it complies with your request and that it suits your application!

1. Unpack the product and visually inspect for any transport damage incurred after leaving our factory.
 2. Depressurise the system before installation or maintenance is carried out!
 3. Locate a suitable point in your compressed air system to connect this product. We advise to install it as close to your compressed air tank as possible and as high as possible.
-

Installation notes:

- *Make sure that no solid matter (e.g. sealing compound residue) gets into the product during the installation.*
 - *Make sure that the pipeline is thoroughly clean.*
 - *Use quality sealing compound only!*
 - *Use proper tools for fixing the valve part to your pipe work! Never use the product as a lever.*
-
4. The motorised ball valve part of this product usually operates in any mounting position. However we recommend that the product is mounted upright or side-ways.
 5. Minimum space required around the unit is 4", to allow for manual operation and programming.
 6. Connect the product to your power supply as illustrated.
- NOTE: grounding is required.*
-
7. Make sure that your power supply voltage and frequency comply with those stated on the product before you switch it on!
 8. Restore system pressure.
 9. The product is ready for programming (see pages 7 - 16).
- Note: We advise to check this product **at least once a year** and replace serviceable parts when necessary.*

1.

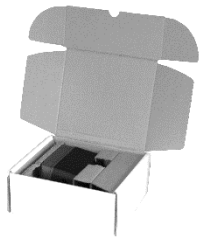

2.

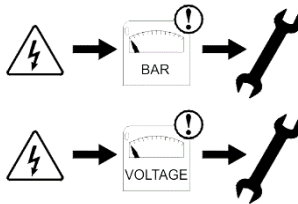

3.

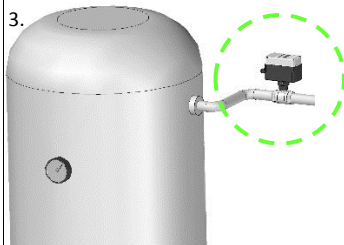

4.

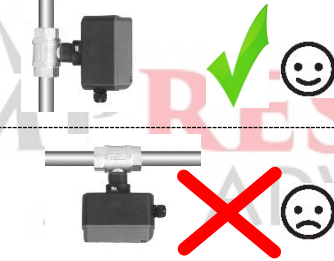
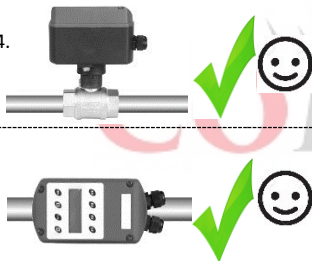

5.

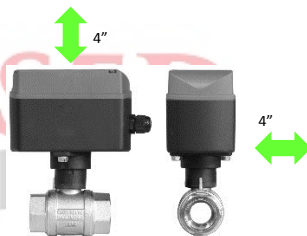

6.

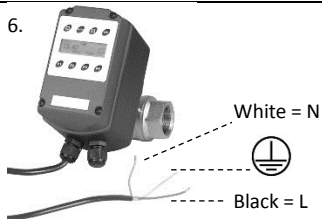

7.

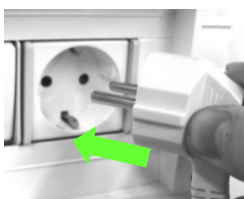

8.

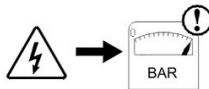

9.



COM

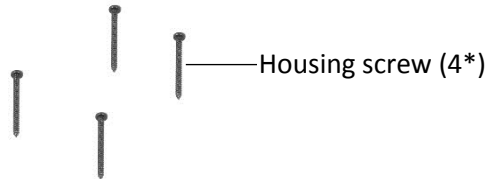

Housing screw (4*)



Housing top part



Housing bottom part



Ball valve

Bolt (2*)



DISPLAY

Press F1 to activate the display (in battery mode).

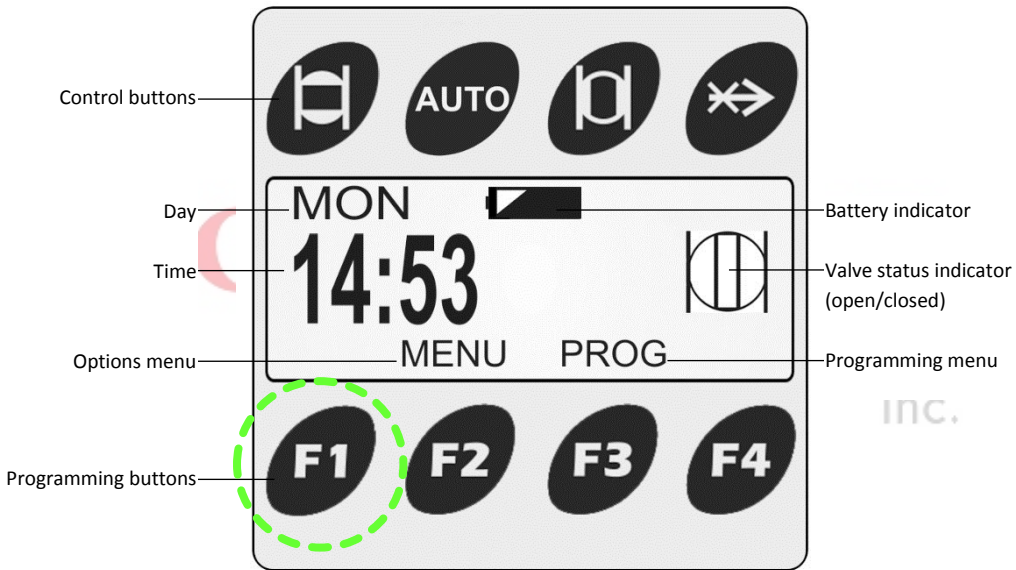

CURRENT DATE AND TIME SETTING 1/2

1. Press F1 to activate the display. Press F2 to select 'MENU'.



2. Press F4 to 'SELECT'.



3. Choose the current day by pressing F2(▼) and F3(▲) to scroll down and up.



4. Press F4(▶) to choose the next setting (hours).



5. Choose the current hour by pressing F2(▼) and F3(▲) to scroll down and up.



6. Press F4(▶) to choose the next setting (minutes).



7. Choose the current minutes by pressing F2(▼) and F3(▲) to scroll down and up.



8. Press F4(▶) to choose  to save the current time setting.



CURRENT DATE AND TIME SETTING 2/2

9. Press F3 to 'SAVE' the current time setting.



10. You will return to the previous menu. The time is now set.



NOTE: You can always select the X and then cancel, to abort your settings. You will then return to the previous menu item.



11. Press F1(HOME) to exit the menu.



12. The time is set.



The unit is pre-programmed to OPEN at 6.00 and CLOSE at 18.00 from Monday to Friday. If this program is not according to your wishes, you can alter these settings by first 'DELETING ALL SETTINGS' (page 15) and then 'PROGRAM THE UNIT' (pages 9-12) to fit your system.

PROGRAMMING THE UNIT 1/4

In this example the unit will be programmed to open weekly at 7:15 and close at 18:15 from Monday to Friday.
We will start with the valve OPEN time settings.

1. Press F1 to activate the display.
Press F3 to select 'PROG'.



2. Press F4 to select 'EDIT' to set the first program setting.



We will start with programming the valve OPEN times.

3. Use F2(▼) and F3(▲) to scroll down and up to select M-F:
- **MON, TUE, WED, THU, FRI, SAT, SUN**
- **ALL** for all days of the week
- **M-F** for MONDAY to FRIDAY
- **S-S** for SATURDAY and SUNDAY



4. Press F4(▶) to choose the next setting (hours).



5. Choose the desired setting by pressing F2(▼) and F3(▲) to scroll down and up.



Set the hours to 7.

6. Press F4(▶) to choose the next setting (minutes).



PROGRAMMING THE UNIT 2/4

7. Choose the desired setting by pressing F2(▼) and F3(▲) to scroll down and up.



Set the minutes to 15.

9. Choose the desired setting by pressing F2(▼) and F3(▲) to scroll down and up.



Set to OPEN.

11. Press F3 to 'SAVE' the current time setting.



8. Press F4(▶) to choose the next setting (open or close).



10. Press F4(▶) to choose ▶ to save the current time setting.



12. You will return to the previous menu.

Note: you can now use F2(▼) and F3(▲) to scroll down and up into the generated list to check the current settings. You will now only see the Monday to Friday OPEN times set at 07:15.



PROGRAMMING THE UNIT 3/4

13. Press F2(▼) and F3(▲) to scroll down and up to select a NEW setting.



14. Press F4 to select 'EDIT' to set the new setting.

We will now program the valve CLOSE times.



15. Use F2(▼) and F3(▲) to scroll down and up to select M-F:

- **MON, TUE, WED, THU, FRI, SAT, SUN**
- **ALL** for all days of the week
- **M-F** for MONDAY to FRIDAY
- **S-S** for SATURDAY and SUNDAY



16. Press F4(▶) to choose the next setting (hours).



17. Choose the desired setting by pressing F2(▼) and F3(▲) to scroll down and up.

Set the hours to 18.



18. Press F4(▶) to choose the next setting (minutes).



PROGRAMMING THE UNIT 4/4

19. Choose the desired setting by pressing F2(▼) and F3(▲) to scroll down and up.

Set the minutes to 15.



20. Press F4(▶) to choose the next setting (open or close).



21. Choose the desired setting by pressing F2(▼) and F3(▲) to scroll down and up.

Set to CLOSE.



22. Press F4(▶) to choose [] to save the current time setting.



23. Press F3 to 'SAVE' the current time setting.

In this example the unit is now programmed to open at 7:15 and close at 18:15 every Monday to Friday.



24. You will return to the previous menu.

Note: You can now use F2(▼) and F3(▲) to scroll down and up into the generated list to check the current settings. You will see the Monday to Friday OPEN and CLOSE times in chronological order. Press F1(HOME) to finish.



ALTERING OR DELETING SETTINGS 1/2

1. Press F1 to activate the display.
Press F3 to select 'PROG'.



2. To **alter** a setting, choose the desired setting by pressing F2(▼) and F3(▲) to scroll down and up.

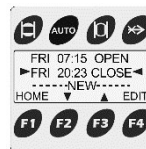

3. Press F4 to select 'EDIT' to alter the setting.



4. Select the setting to alter by pressing F1(◀) and F4(▶) and change it by pressing F2(▼) and F3(▲).

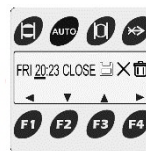

5. Save the altered setting by pressing F4(▶) to choose  and pressing F3 to 'SAVE' the current time setting.



6. To **delete** a setting choose the desired setting by pressing F2(▼) and F3(▲) to scroll down and up.

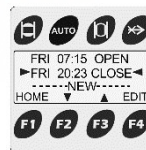

ALTERING OR DELETING SETTINGS 2/2

7. Press F4 to select 'EDIT' to alter the setting.



8. Press F4(▶) to choose  to delete the selected setting.



9. Press F3 to 'DELETE' the selected setting.



10. Press F1(YES) to delete or F4(NO) to cancel.

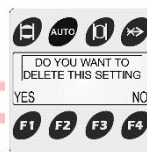

11. You will return to the previous menu.



12. Press F1(HOME) to return to the HOME screen.



TO DELETE ALL SETTINGS

1. Press F1 to activate the display. Press F2(MENU) to enter the menu.



2. Press F2(▼) to scroll to 'FACTORY RESET' and press F4 to select.



3. Press F1+F2 simultaneous to confirm (YES) or F4 to cancel (NO)

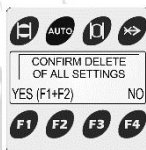

4. The unit has now been reset and the complete memory has been deleted.

First action is to set the current day and time, see page 7-8 for the procedure.

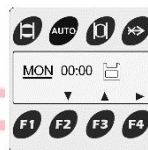

LANGUAGE SELECTION

You can change the language of the unit. The unit is equipped with pre-installed languages, i.e. English, Deutsch, Español, Nederlands and Français.

1. Press F1 to activate the display. Press F2(MENU) to enter the menu.



2. Use F2(▼) to scroll down to select 'LANGUAGE' and press F4(SELECT) to enter the menu.



3. Choose your desired language by pressing F2(▼) and F3(▲) to scroll down and up.





4. Press F4(SELECT) to change to your desired language.



5. Press F1(HOME) to return to the HOME screen.



OPEN AND CLOSE BUTTON & PROGRAM OVERRIDE BUTTON

1. You can open or close the ball valve by pressing the OPEN  or CLOSE  button on the unit.





2. A WARNING  will appear on the display to point out that the altered OPEN or CLOSED state of the ball valve is not according to the set program.



3. Press AUTO  to go back to the programmed open/close cycle.



By pressing the OVERRIDE  button you will override the program for this day, meaning the ball valve will be closed from the time you press the OVERRIDE  button, until 00:00 the same day. When in OVERRIDE mode the override symbol  will be displayed.



BATTERY

The clock operates on four(4) AAA size, 1.5V (mini penlight) batteries. The batteries only act as a battery back-up for the clock during a power failure. The batteries do not operate the valve in the case of a power failure. The battery indicator on the display shows when it is time to replace the batteries. Rely as little as possible on the battery back-up.



Batteries full,
no action required.



Batteries half full,
no immediate action required.



Batteries nearly empty,
time to replace batteries.

1. To (re)place the batteries, open the housing by unscrewing the 4 housing screws.

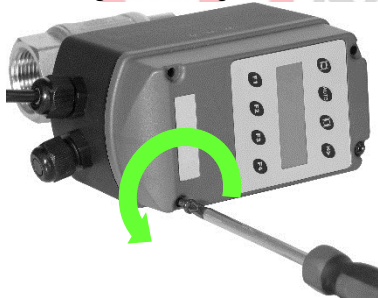

2. Place the 4 batteries and close the housing by replacing the 4 housing screws.

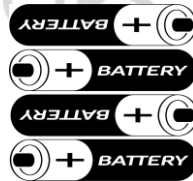

USEFULL FEATURES 1/2

MANUAL OVERRIDE

You can manually open and close the valve by (1.) pushing the actuator towards the ball valve and (2.) turning it left or right 90°.

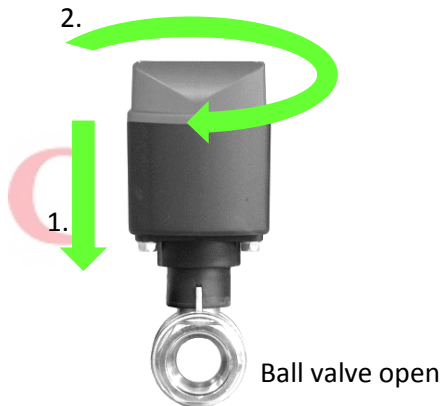

Please note: After a manual override the actuator will be 90° rotated versus the ball valve. All indicators and settings will become reversed, meaning the pre-programmed OPEN and CLOSE settings will become reverse, i.e. OPEN will become CLOSED and CLOSED will become OPEN.

USEFULL FEATURES (2/2)

VALVE INDICATOR

The ball valve is equipped with a valve position indicator. It will show you the position of the valve, OPEN or CLOSED.

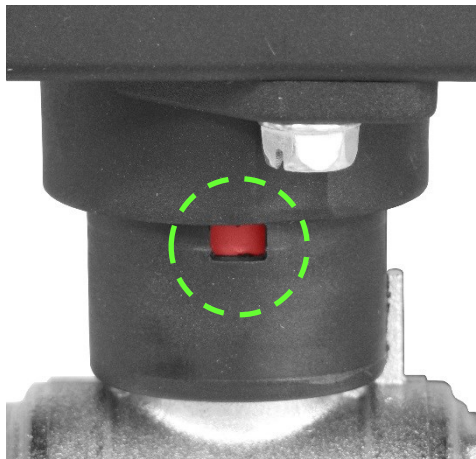

RED = OPEN

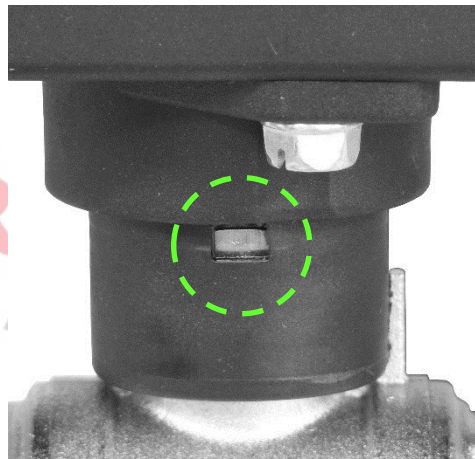

No colour (metal) = CLOSED

TECHNICAL SPECIFICATIONS

Pressure range	0 - 16 bar	0 – 230 psi
Supply voltage options	115VAC <i>or</i> 230VAC 50/60Hz. (please check label)	
Opening/Closing duration	30 sec. / 90°	
Medium temperature	1 - 100 °C	34 – 210 °F
Ambient temperature	1 - 50 °C	34 – 120 °F
Timer display	LCD	
Programmable options	Weekplanner, max. 100 switching points, to be distributed over 1-7 days.	
Inlet/Outlet connections	1" (BSP or NPT)	
Valve housing material	Brass, nickel plated	
Serviceable valve	Yes	
Manual override	Yes	
Remote controllable	Yes	
Environmental protection	IP54 (NEMA13)	

DIMENSIONS

