

AIR-SAVER®

Compressed air and energy saver

Principle workings of the AIR-SAVER

All compressed air systems have leaks. Pipe connections, condensate drains, instruments, hoses and fittings - all of these are potential leak points, and these leaks can be expensive. They cause your compressor to operate even when you aren't there, cycling on and off to maintain pressure during evenings and weekends when it isn't required. Even a small 1/8" hole can cost more than \$2,000 a year in electricity due to increased compressor run time*.

The AIR-SAVER is a simple timed valve that isolates your compressor and compressed air storage tank from the rest of your compressed air system. Using a programmable timer, it opens just before each shift starts and closes just after each shift ends, ensuring you never lose valuable compressed air to leaks.

Even if you turn your compressor off at the end of the day, leaks will consume all the air in your compressed air storage tank, requiring you to repressurize the tank again the next morning. The AIR-SAVER isolates your storage tank ensuring it remains at full pressure ready for the following day, saving both time and energy.

COMMERCIAL BENEFITS

- Fully automatic operation – Just set it & forget it!
- Intuitive programmable microprocessor (7 day program to match your work week).
- Language selection feature (English, German, Spanish, French and Dutch).
- LCD displaying the program cycle and the current time.
- External push button controls (disassembly not necessary).
- Battery life indication in the display.
- Fully automatic - no maintenance.
- Small compact design.
- Private labelling options.

TECHNICAL ADVANTAGES

- Maintenance free design.
- Easy to program and adjust through digital display.
- FPM seals.
- Stainless steel ball, valve is nickel plated brass.
- Slow ball valve rotation prevents rapid pressure changes (designed to avoid water-hammer when opening or closing).
- Extended programming features relating to valve open and close cycles (100).

* based on 8,000 hours of run time, and \$0.06/kWh



AIR-SAVER®

Compressed air and energy saver

PRODUCT DIMENSIONS

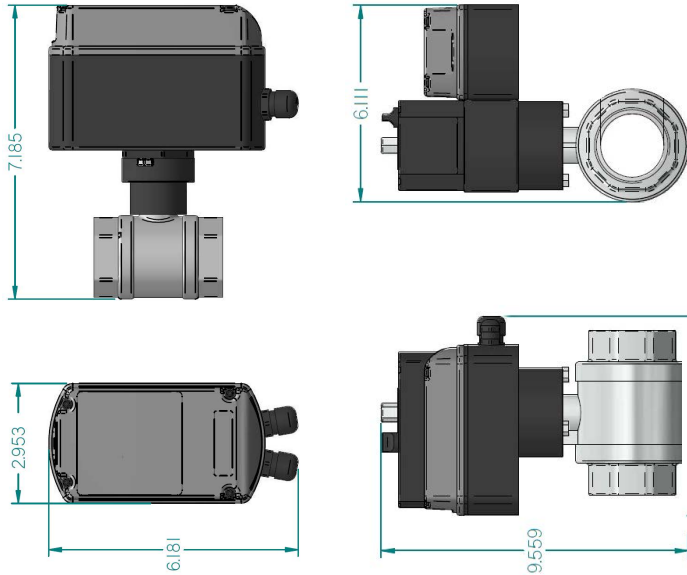

Built-in quartz controlled timer with LCD display.

SPECIFICATIONS

Supply voltage	230VAC or 115VAC 50/60 Hz
Power consumption	7W during cycle rotation
Opening/Closing duration	1": 30 sec, 2": 105 sec /90°
Max. ambient temperature	140 °F
Max. medium temperature	212 °F
Minimum pressure	0 psi
Maximum pressure	230 psi
Valve	1" or 2" connection
Valve	Brass/nickel plated
Manual override	Yes
Remote controllable	Yes
Environmental protection	NEMA13 (IP54)
Timer display	24 hours
Programmable options	16 cycles/day, 7 days/week



Remote control option.

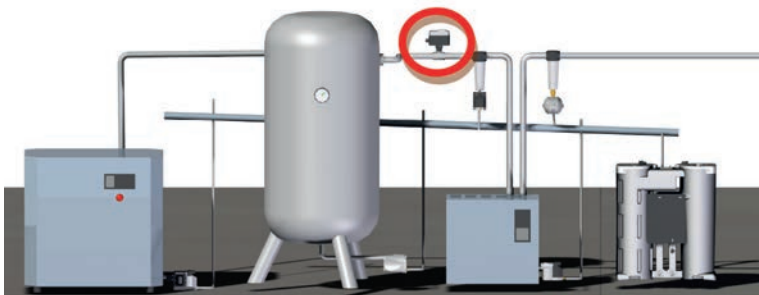

Should there be an electrical power failure, then the ball valve can be manually opened or closed.

Information provided herewith is believed to be accurate and reliable. However, no responsibility is assumed for its use or for any infringement of patents or rights of others, which may result from its use. In addition, JORC reserves the right to revise information without notice and without incurring any obligation

Compressed Air Advisors, Inc.

Phone: 877.247.2381

info@compressedairadvisors.com

www.compressedairadvisors.com