

Compressed Air Advisors, Inc.

Phone: 877.247.2381

info@compressedairadvisors.com

www.compressedairadvisors.com

- REVISIONS -							
ZONE	REV	DESCRIPTION	CHG BY	CHK BY	APP BY	REL BY	DATE
-	A	UPDATED, REMOVE CAT# DUE TO CONFIG. REVISE CAPACITY MM-4.	DBR	DBR	DBR	SDM	07/27/04
-	B	REMOVED LOGO CATALOG NUMBER CALLOUTS.	SDM	DEH	DBR	SDM	10/16/06
-	C	UPDATED BRAND LOGOS.	SDM	CRH	DBR	SDM	10/02/13

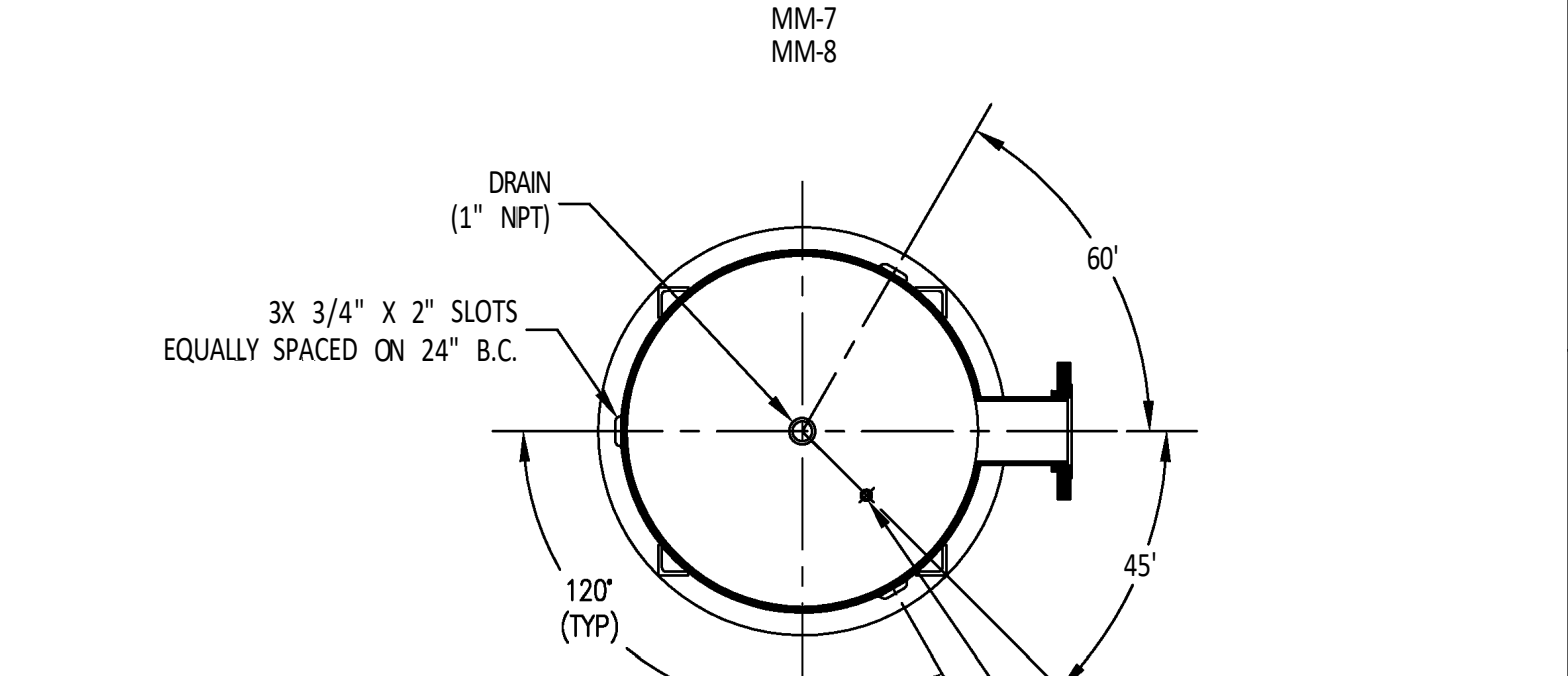
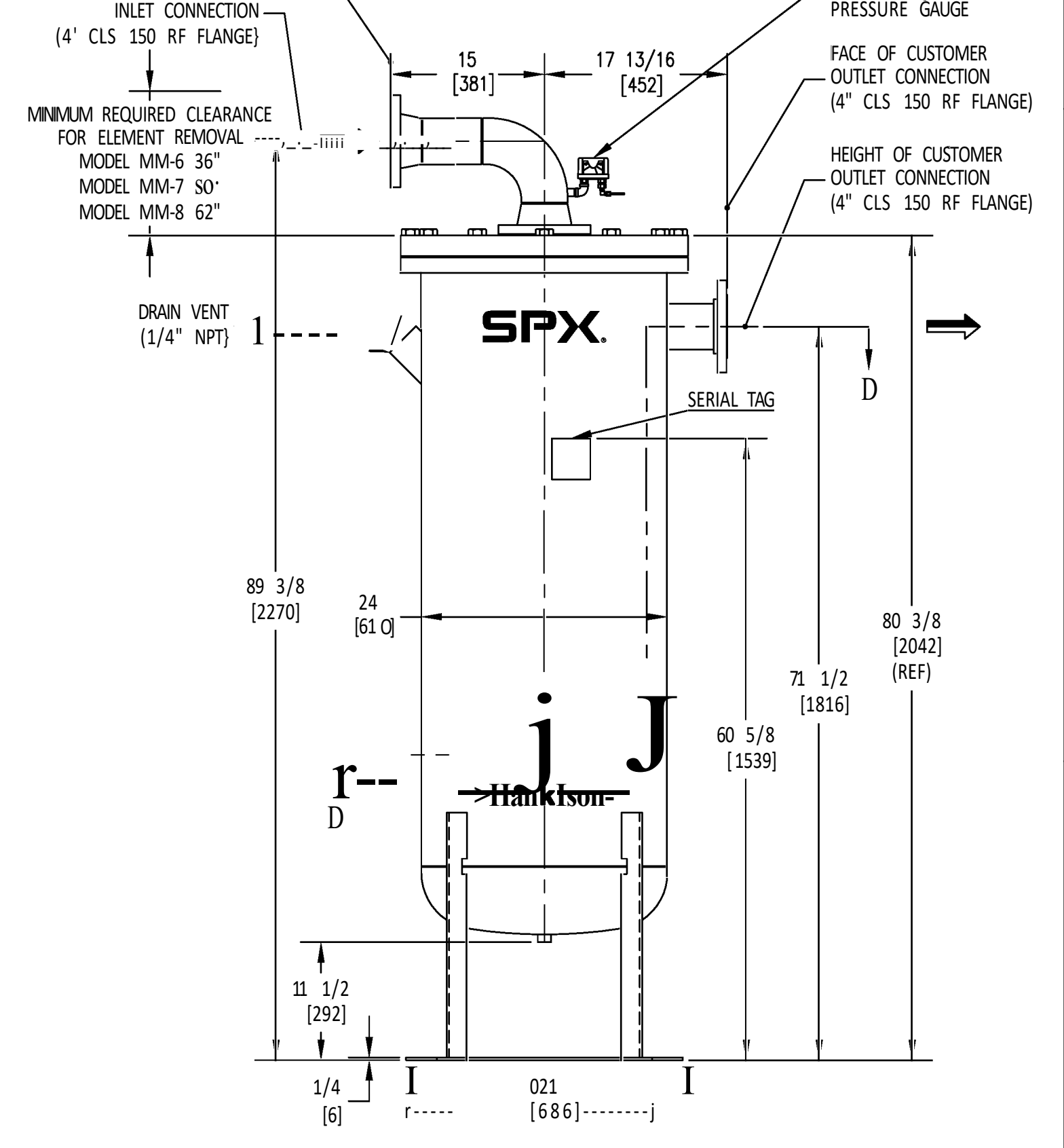
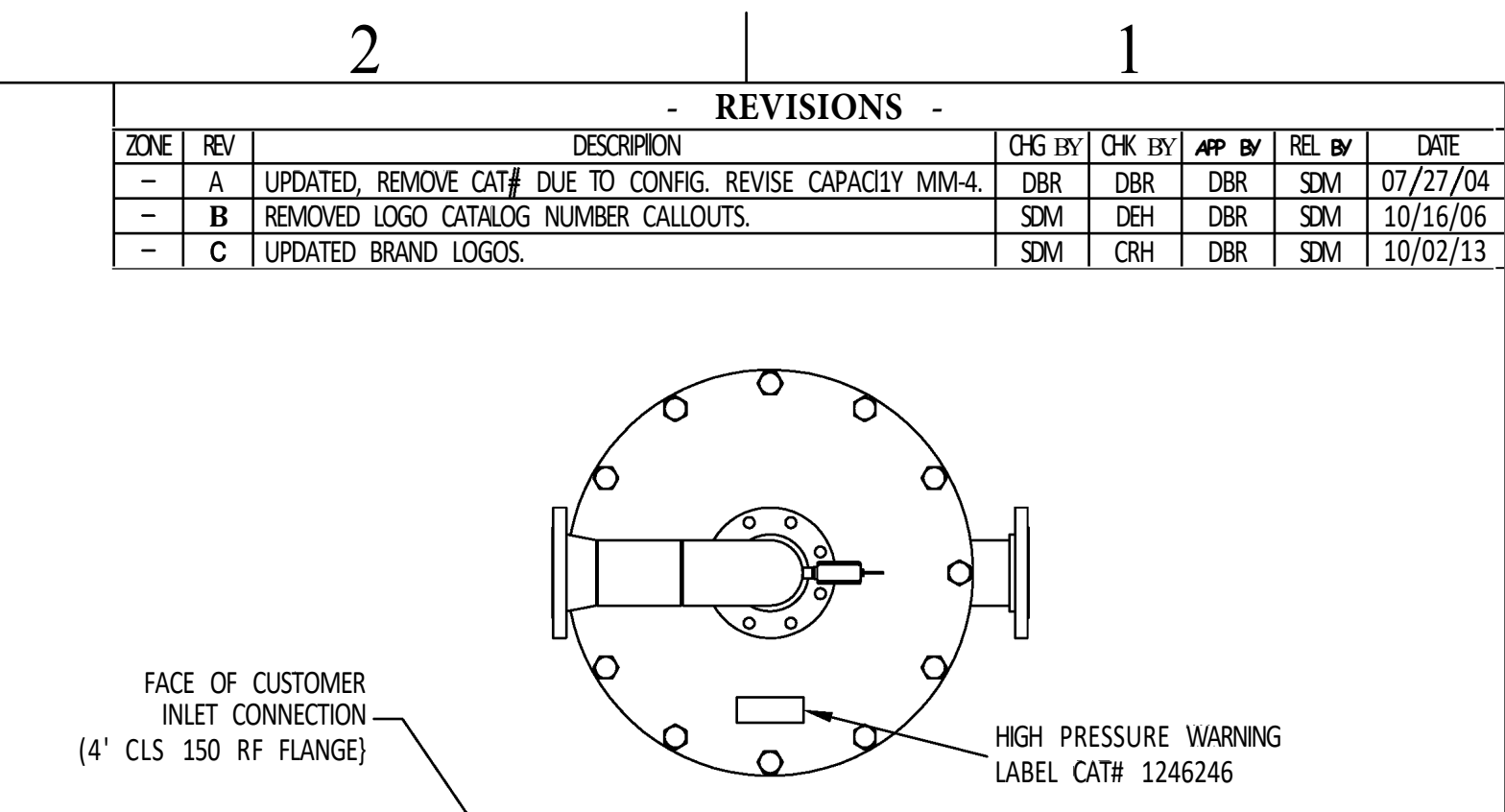
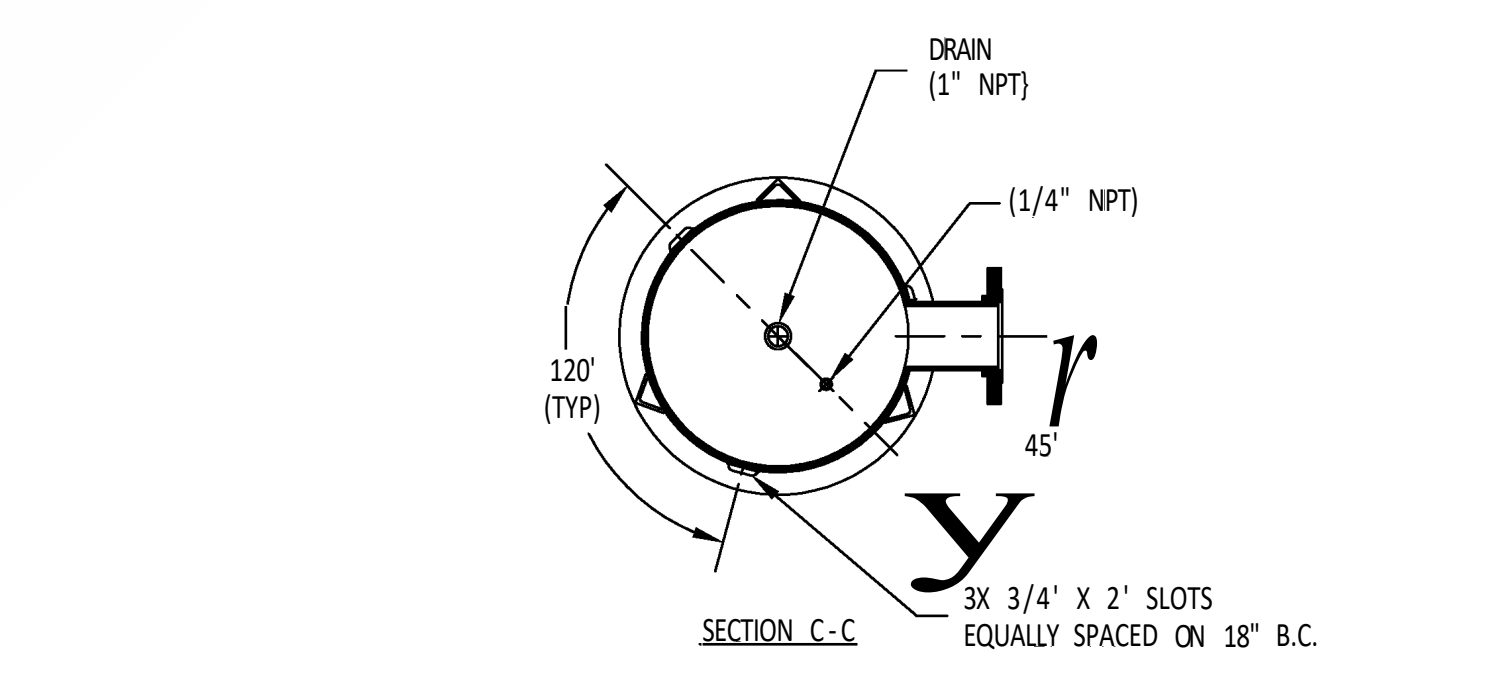
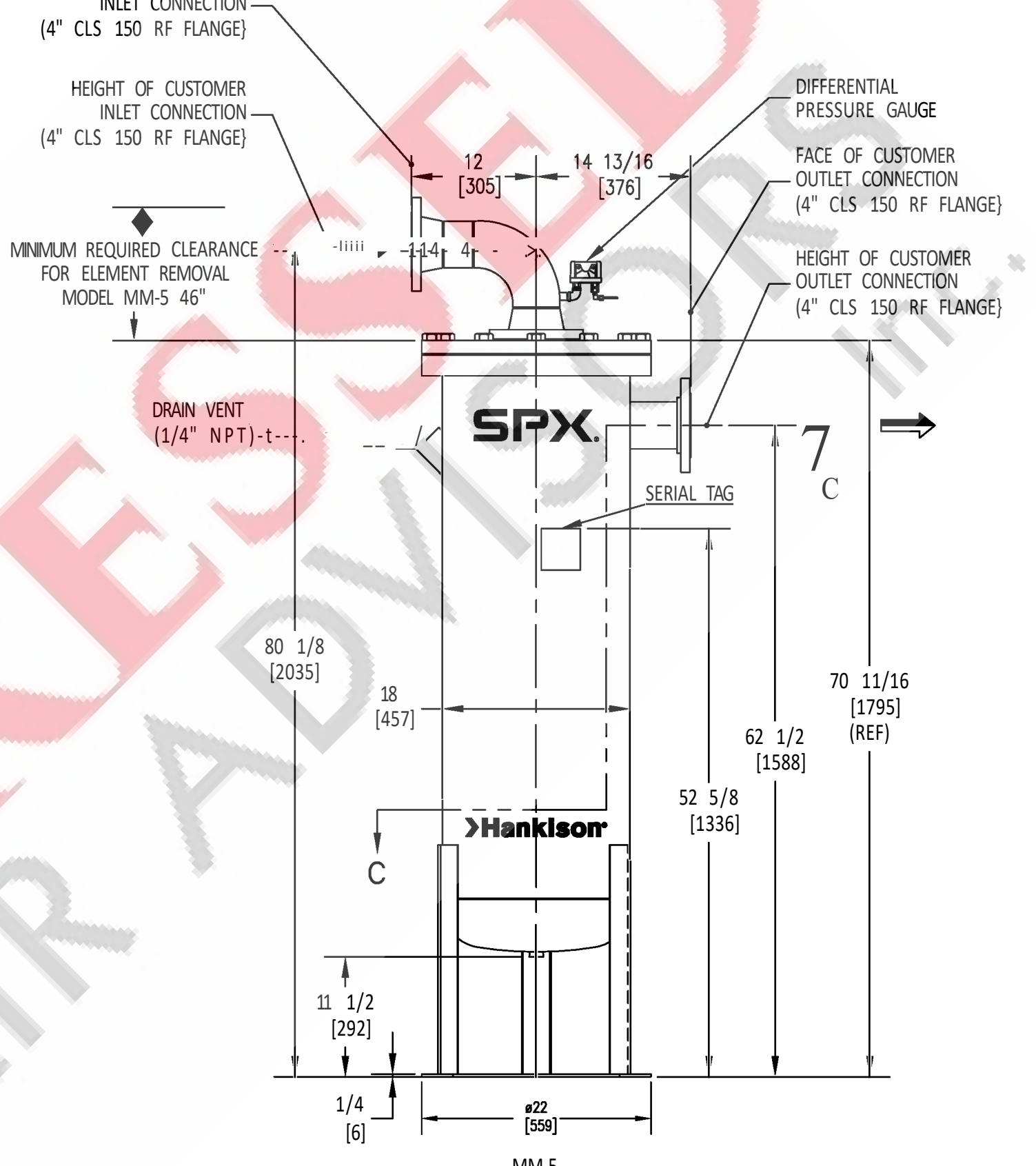
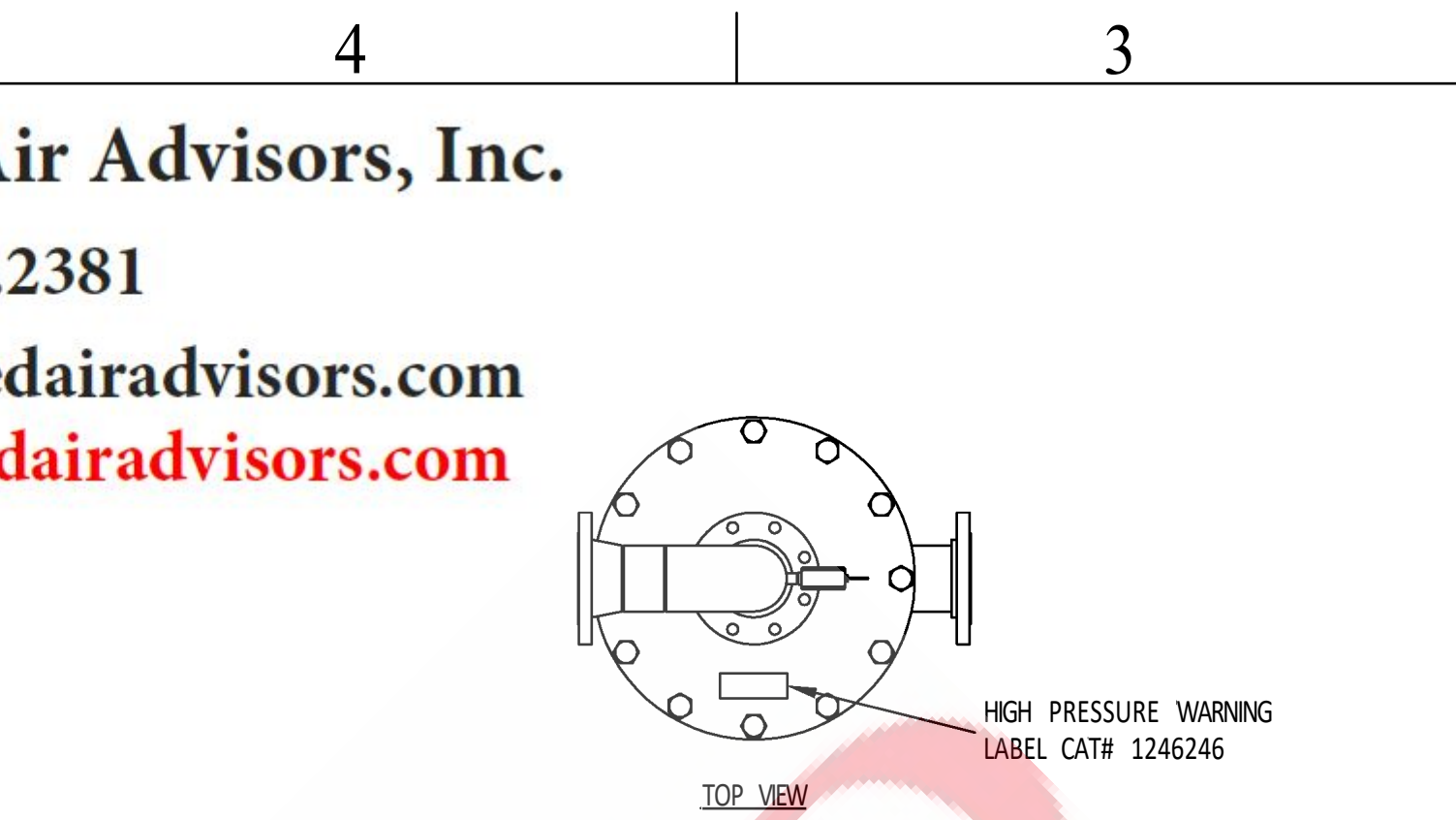
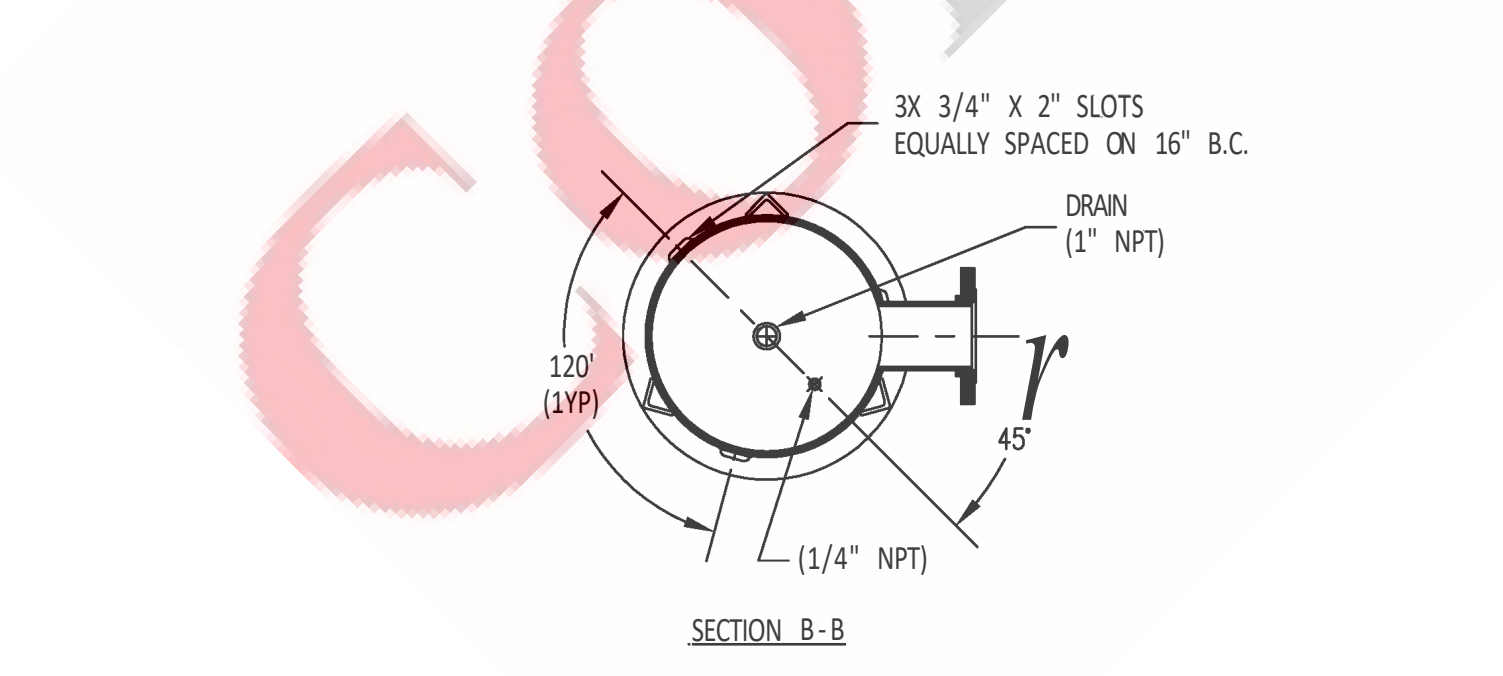
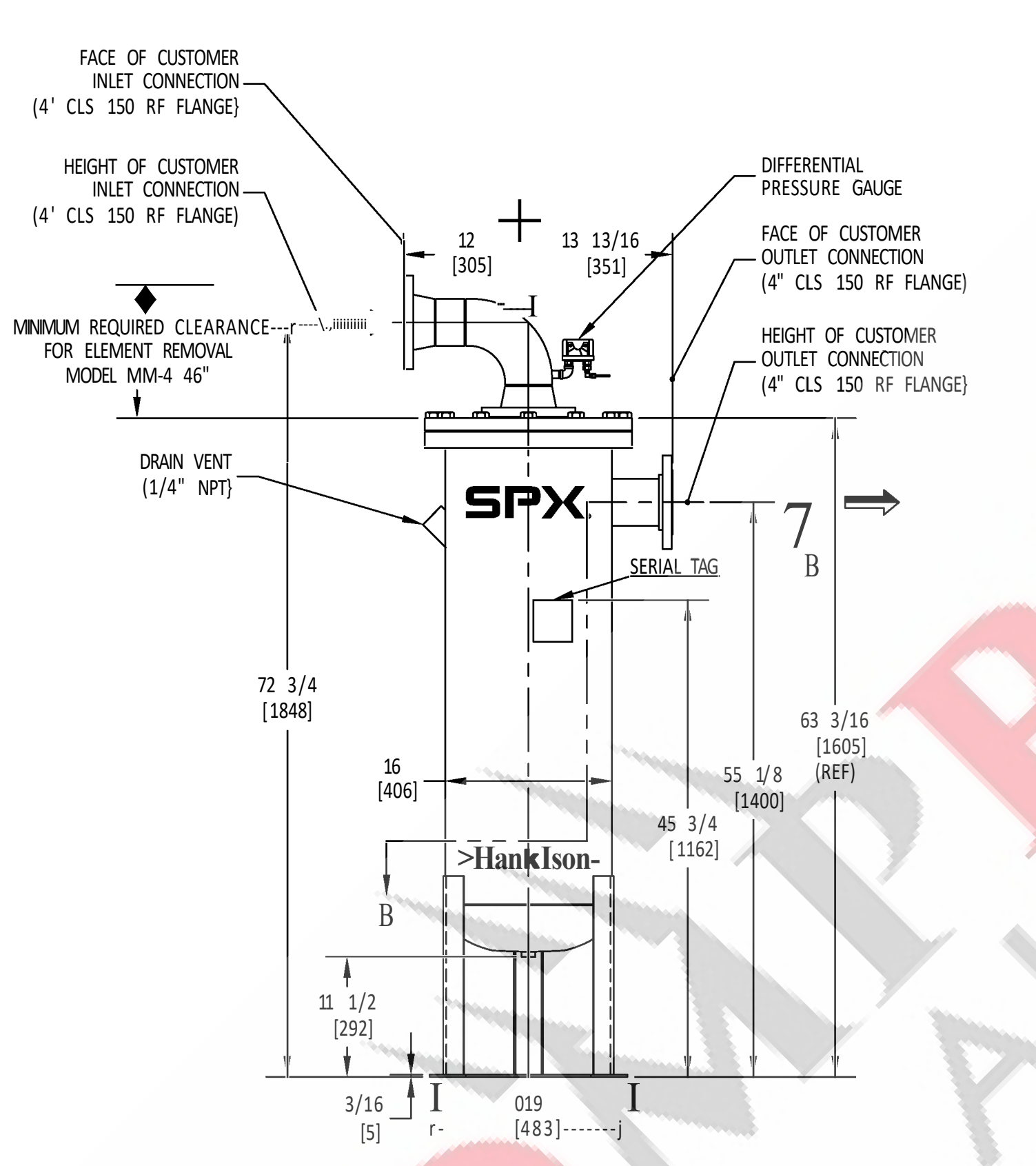
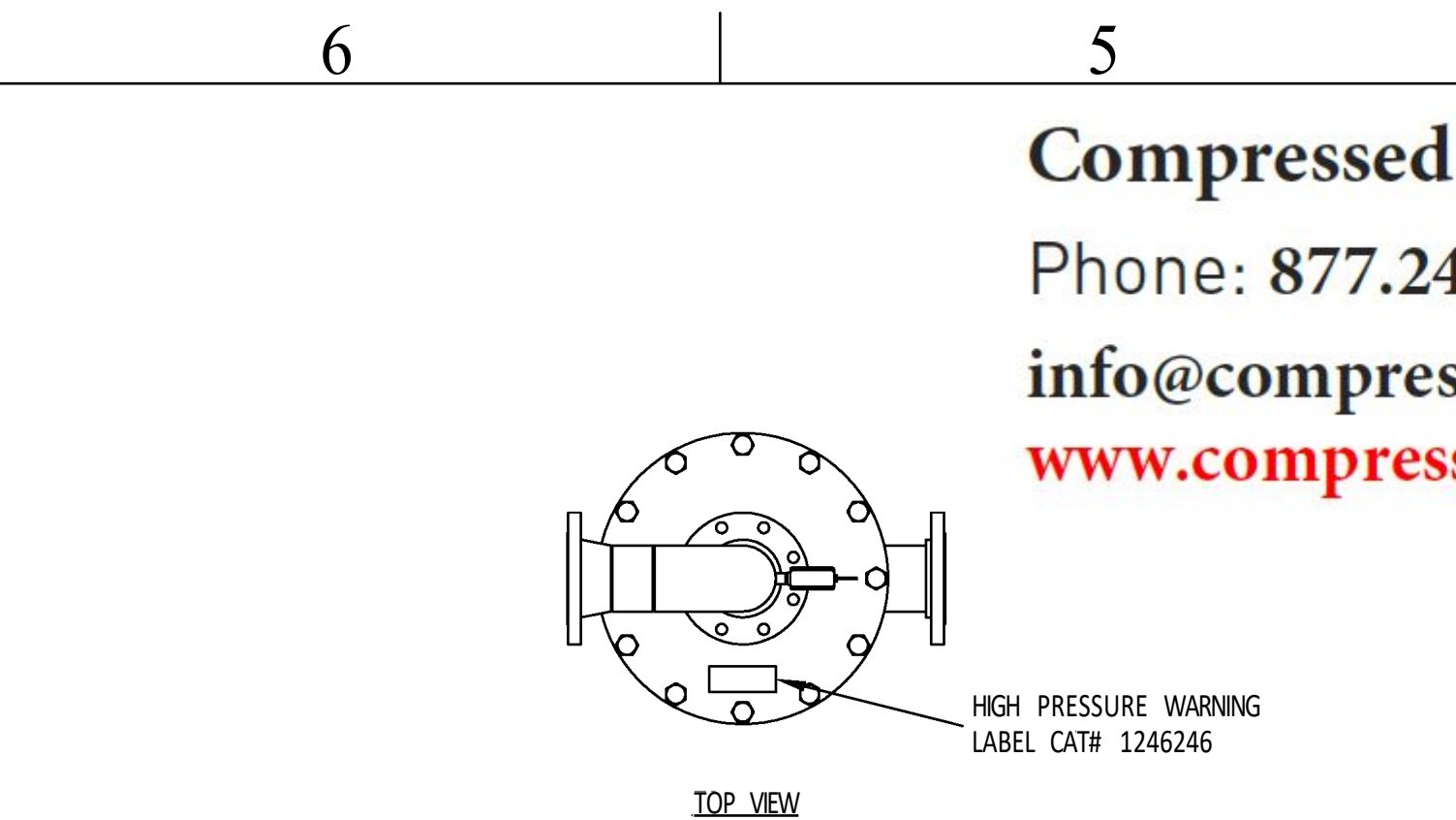
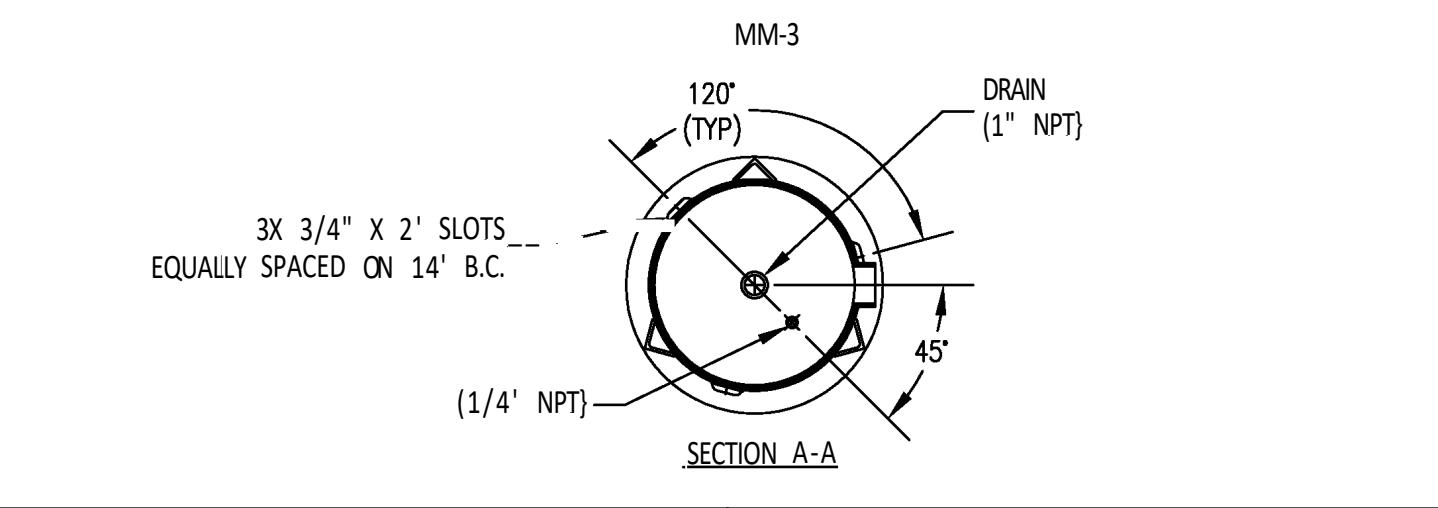
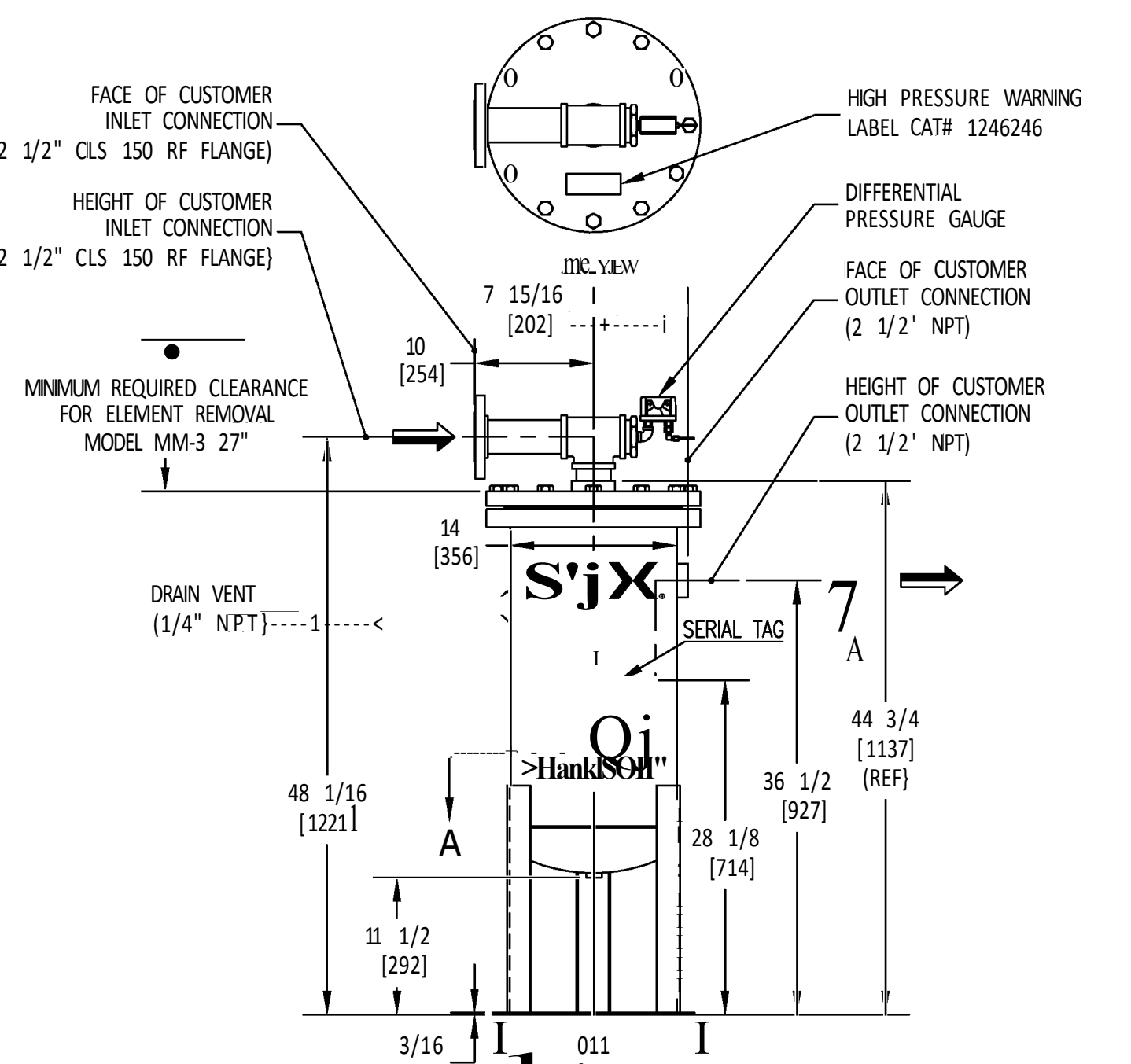
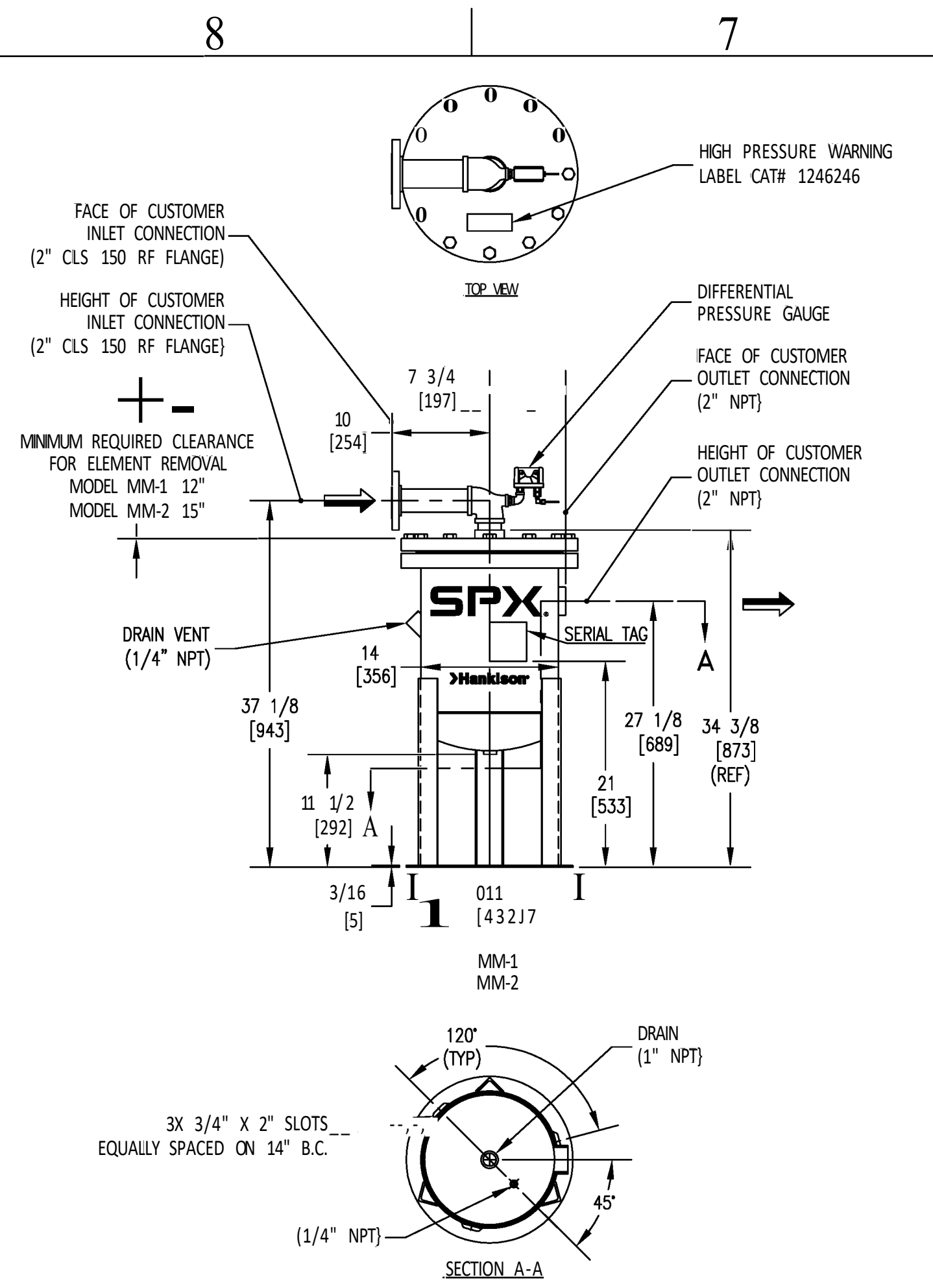

MODEL	CAPACITIES								APPROX. SHIPPING WEIGHT	REPLACEMENT ELEMENT
	70 PSIG	80 PSIG	90 PSIG	100 PSIG	110 PSIG	120 PSIG	130 PSIG	150 PSIG		
MM-1	92	103	114	125	136	147	158	179	225 LBS	4001416
MM-2	185	206	228	250	272	294	315	359	225 LBS	4001417
MM-3	369	413	456	500	544	587	631	718	250 LBS	4001418
MM-4	812	908	1004	1100	1196	1292	1388	1580	375 LBS	4001419
MM-5	1108	1238	1369	1500	1631	1762	1892	2154	525 LBS	4001421
MM-6	1551	1734	1917	2100	2283	2466	2649	3015	750 LBS	4001422
MM-7	1772	1982	2191	2400	2609	2818	3028	3446	850 LBS	4001423
MM-8	2215	2477	2738	3000	3262	3523	3785	4308	850 LBS	4001424

NOTES:
 1. THIS DRAWING PROVIDES INSTALLATION, MOUNTING, AND CONNECTION REQUIREMENTS.
 2. PRESSURE VESSELS ARE DESIGNED AND BUILT IN ACCORDANCE WITH THE CURRENT CODE AND ADDENDA OF SECTION VIII, DIV. 1, OF THE A.S.M.E. CODE FOR UNFIRED PRESSURE VESSELS.
 3. ANCHOR BOLTS ARE TO PROJECT A MINIMUM OF 2" ABOVE THE FOUNDATION. ANCHOR BOLTS SHOULD BE INSTALLED IN SLEEVES TO ALLOW SOME ADJUSTMENT AT TIME OF INSTALLATION.
 4. FOR MAINTENANCE PURPOSES, RECOMMENDED CLEARANCE AROUND DEMISTER IS 4 FEET (1220 MM).
 5. ALL CONNECTION FLANGES BOLT HOLES TO STRADDLE CENTERLINES.
 ELEMENT CONSTRUCTION:
 1. CARBON STEEL AND SPECIAL GLASS FIBER PACKAGING.
 VESSEL CONSTRUCTION:
 1. CARBON STEEL, DESIGN PRESSURE 150 PSIG, DESIGN TEMPERATURE: 150°F
 MADE AND STAMPED IN ACCORDANCE WITH A.S.M.E. CODE, SECTION VIII.
 MANUAL# 3151682

UNLESS OTHERWISE SPECIFIED:

NAME	DATE	UNAUTHORIZED USE, MANUFACTURE, OR REPRODUCTION IN WHOLE OR IN PART IS PROHIBITED. DRAWING DESIGN AND OTHER DISCUSSIONS ARE PROPERTY OF
DWN BY DBR	01/21/04	>Hankison
ENG BY DBR	01/21/04	
SURFACE FINISH: N/A	CHK BY RMC	DO NOT SCALE. USE DIMENSIONS ONLY.
TOL: MM INCHES	CHK BY RMC	01/21/04
X	APP BY DBR	01/21/04
.X	REL BY SDM	01/21/04
.XX	CAT NO. SEE TABLE	SIZE DWG. NO. 0029000-3
.XXX	ID NO.	REV. SHEET C 1/1

GENERAL ARRANGEMENT
 MODELS MM-1,2,3,4,5,6,7,8