

ZONE		REV	DESCRIPTION	DATE	DWN	CHK
A		A	RELEASED PER ECN 1060490	1/15/14	KWT	DA
B		B	UPDATED RECEIVER: ECN 1080363			

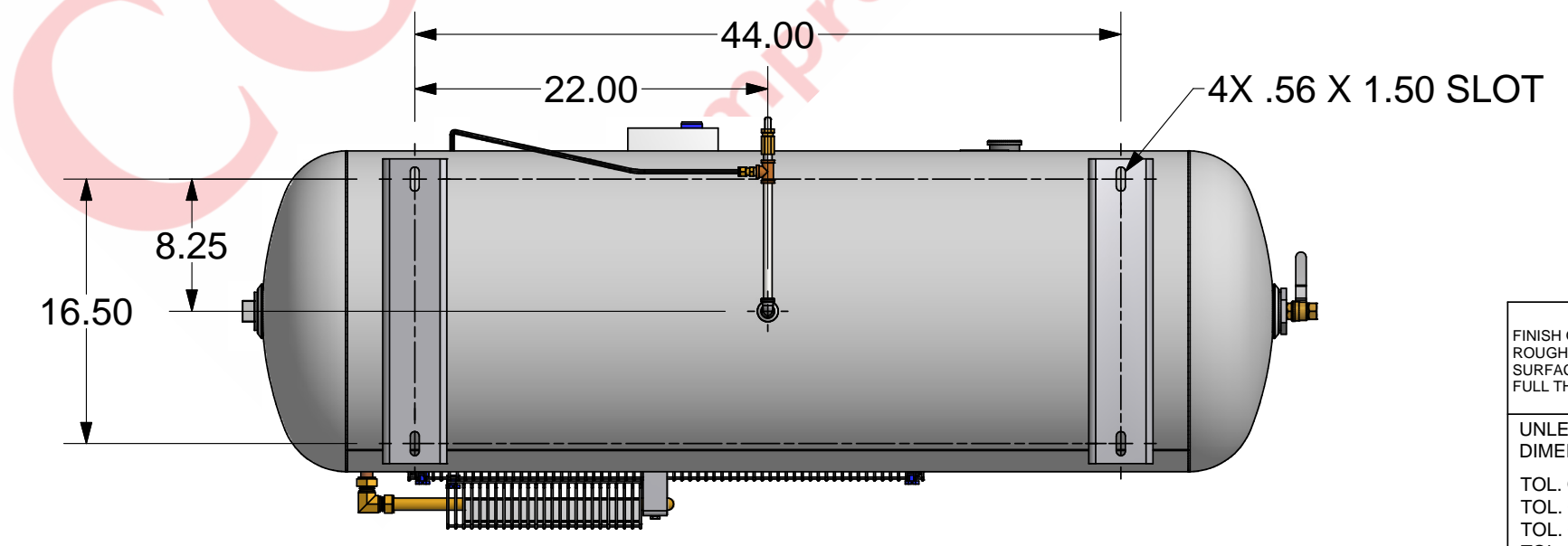
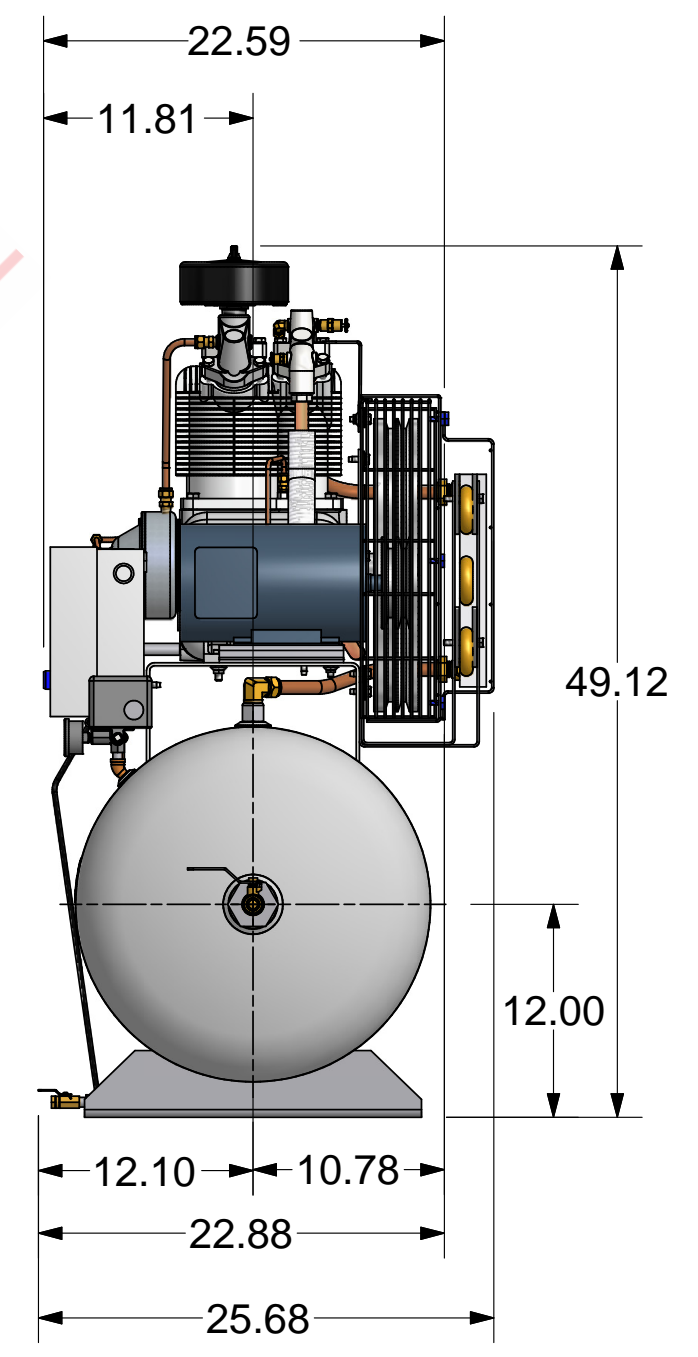
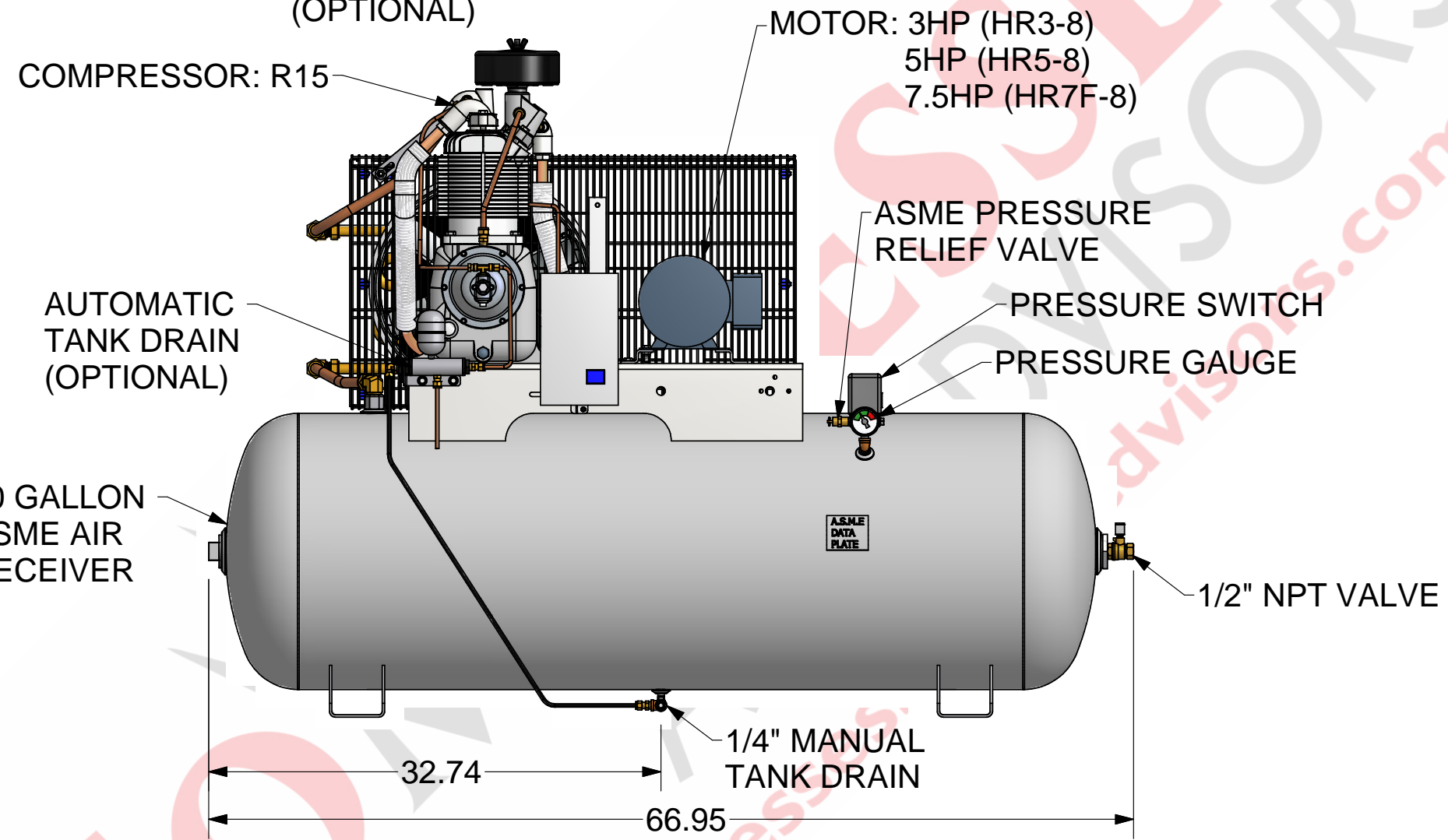
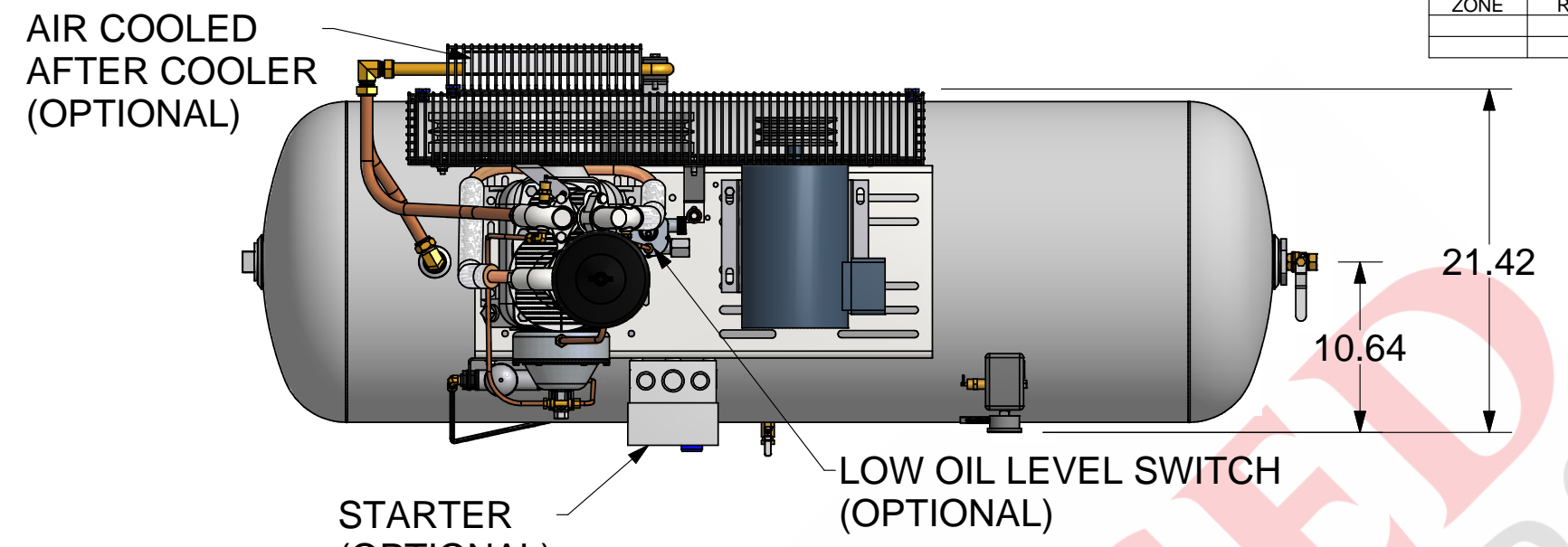
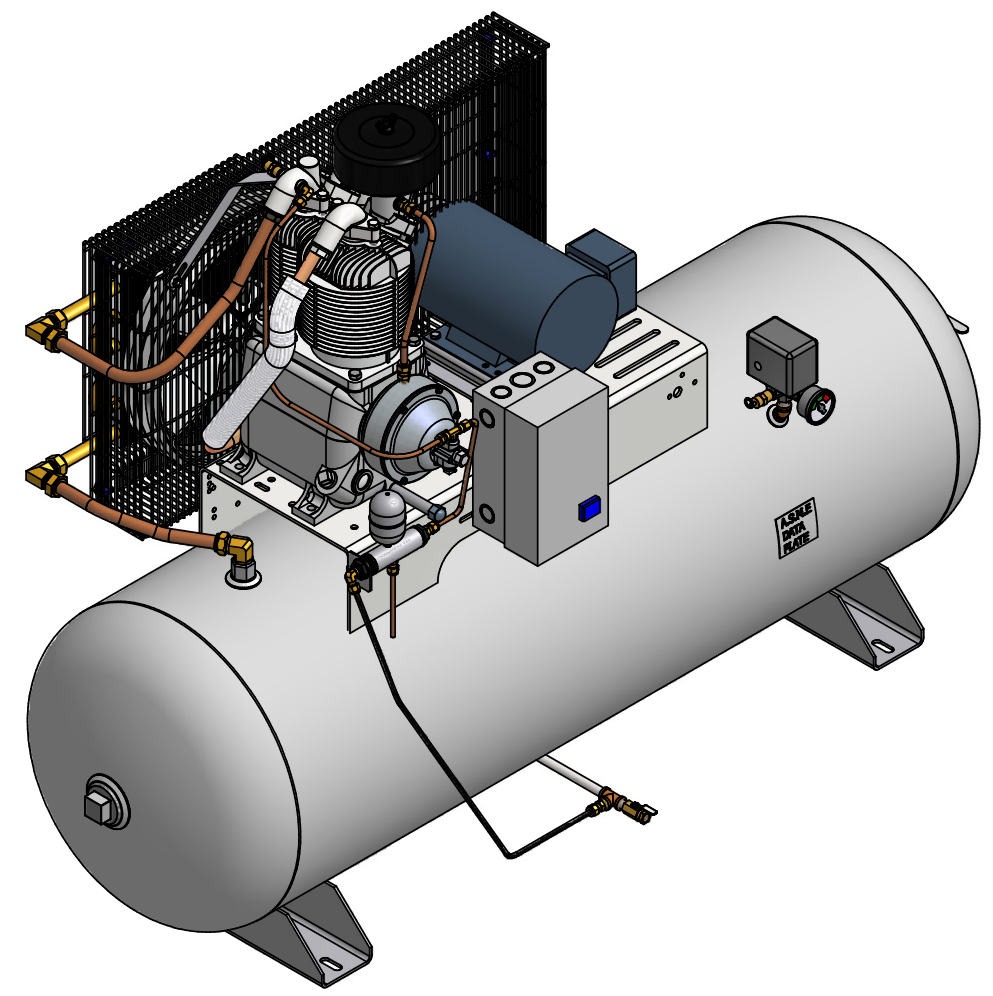

COMPRESSED
AIR ADVISORS
Inc.
Compressed Air Advisors, Inc.
Phone: 877.247.2381
info@compressedairadvisors.com
www.compressedairadvisors.com

FINISH OF CHAMFERS AND FILLETS TO CONFORM TO ROUGHEST ADJACENT AREA. SURFACE ROUGHNESS MAXIMUM PER ASME B46.1. FULL THREAD DEPTHS ARE MINIMUM.		CONFIDENTIAL - THE INFORMATION CONTAINED IN THIS DOCUMENT IS THE PROPERTY OF GARDNER DENVER, INC. IT IS NOT FOR PUBLIC DISCLOSURE. POSSESSION OF THE INFORMATION DOES NOT CONVEY ANY RIGHT TO LOAN, SELL OR DISCLOSE THE INFORMATION. UNAUTHORIZED REPRODUCTION OR USE OF THE INFORMATION IS PROHIBITED. THIS DOCUMENT IS TO BE RETURNED TO GARDNER DENVER, INC. UPON THE COMPLETION OF THE PURPOSE FOR WHICH IT IS LOANED OR UPON REQUEST.	
UNLESS OTHERWISE SPECIFIED DIMENSIONS ARE IN INCHES TOL. ON DECIMALS: .X = ± .05 TOL. ON DECIMALS: .XX = ± .02 TOL. ON DECIMALS: .XXX = ± AS SPECIFIED TOL. ON ANGLES: ± 0°-30'		DIMENSIONING AND TOLERANCING PER ASME Y14.5-2009 THREADS PER ASME B1.1 GAGING SYSTEM 21 U.O.S., ANSI B1.20.1 & B1.20.3	
THIRD ANGLE PROJECTION		HEAT TREATMENT	ENG. REF:
		TITLE HR3-8, HR5-8, HR7F-8	
DWN BY KWT 6/14/2011	SIZE D	ENGR. APPROVAL DA	DWG. NO. 320CAS800
CKD BY DA 6/14/2011	SCALE 1/7	REV B	SHEET 1 OF 1