

Compressor: 5HP/7.5HP Cast Iron

Air Filter

Discharge Tube

Motor: 5HP

Starter: 5HP

Pressure Switch

0-300 PSI Gauge

3/4" Ball Valve

Drain Valve

35.31

Safety Valve

71.50

24.00

Slot: .675" x 1.125"L (4X)

Ø26.0 Bolt Circle

COMPRESSED
 AIR ADVISORS
 — www.compressedairadvisors.com —

ED	DESCRIPTION	DN	DATE	BY

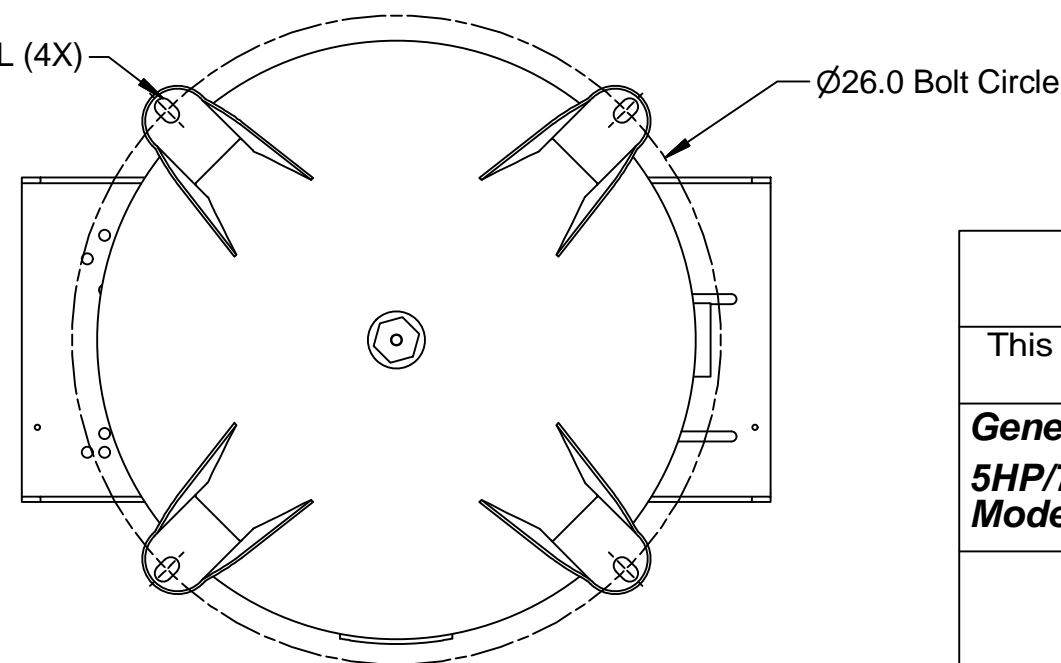

	Paint Spec.	Tolerance	P/N Stamping	
	1310 9203 85	1310 9000 00	1310 9039 51	
This document is our property and shall not without our permission be altered, copied, used for manufacturing, or communication to any other person or company.				
General Arrangement			CP	Secrecy Class
5HP/7.5HP 80 Gallon Vertical				1102 K / 2
Model: RCP-C581V-583V-583VS-7581V-7583V_908113				Unless specified dimensions are in inches
	Matr'l	See Drawing	Owner	HOP
	Scale	N/A	Replaces	3rd angle proj.
	Drawn by	DD	Blank	
	Date	1/27/2014	DWG Status	RELEASED
			Part Number	1312 9081 13
			Sheet	1 of 1
			Rev	00