

**D5  
Rotary Screw  
Air Compressor  
Units  
---  
Installation  
And  
Service Data**

**Contents:**

**Page:**

Quick Start .....	2
Safety Precautions .....	4
Unpacking and Inspection .....	5
Installation – Mechanical .....	6
Lubrication .....	8
Installation – Electrical .....	9
Motor maintenance instructions .....	11
Start-up Procedures .....	12
Preventative Maintenance Schedule .....	13
Maintenance procedures .....	15
'CSC15' Controller.....	22
Common Compressor Faults .....	26
Separator Filter and Refrigerated Air Dryer.....	27
Troubleshooting Guide .....	30
Warranty .....	33



**Please read this manual before installing or using your Air Compressor Unit. It contains valuable information that will help in the receiving, installation, use, and maintenance of the Unit.**

**Please keep this manual in a safe place for future reference.**

All of the information, policies, and procedures in this reference manual apply exclusively to Champion.

Authorized distributor service technicians are factory trained and skilled in compressor maintenance and repair. They are ready to respond and assist you by providing fast, expert maintenance and repair services.



Compressed Air Advisors, Inc.

Phone: 877.247.2381

info@compressedairadvisors.com

[www.compressedairadvisors.com](http://www.compressedairadvisors.com)

## Quick Start

### Mechanical Installation

(Refer to Page 6)

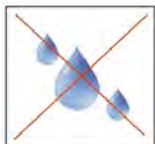

- The Unit must be located indoors, in a dry, clean, cool, dust free, and well ventilated area.
- Allow a minimum 18" (458mm) around and 36" (915mm) above Unit.
- The ambient temperature should be between 10°C and 40°C (50°F and 104°F).
- Ensure that the floor under the Unit is smooth, level and capable of bearing the weight of the Compressor.
- If installed in a compressor room, ensure that the room is adequately ventilated.
- The unit must be anchored to the floor using isolator pads.

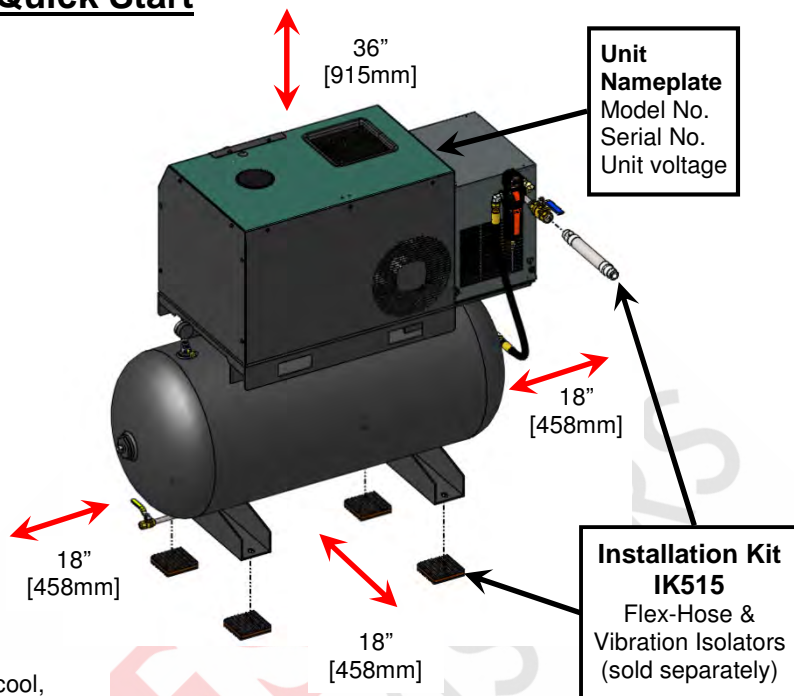

### CAUTION

**Drain condensate (water) from oil tank.**  
**If compressor work-cycle experiences long pauses, condensate will gather in oil tank.**  
**Drain condensate EVERY 50HRS OR WEEKLY.**  
(Refer to Page 8 for details)

### Lubrication

(Refer to Page 8)

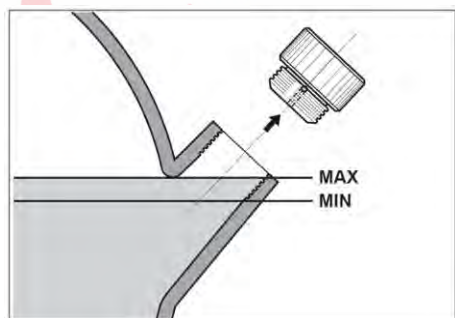

- Ensure the oil level in the Air End is between the top (maximum) or bottom (minimum) thread as shown.

### Rotation

(Refer to Page 10)

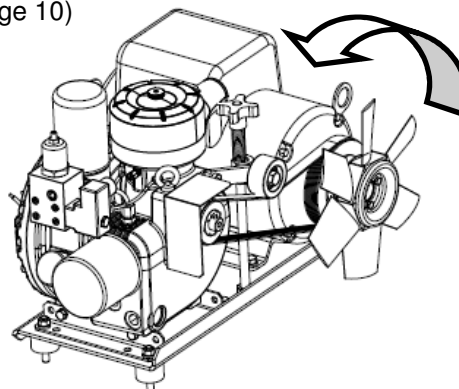

- The correct rotation is as shown.
- The Unit is equipped with an Anti-Rotation Switch. Check that the rotation is correct.

## Quick Start (cont'd)

### Unit Operation

Shown below is the 'CSC15' Controller which regulates the operation of the Unit. Unit Status LEDs, Hour Meter, and ON/OFF switch are located on the control panel cover.

**Starting the Unit:** Turn the Selector Switch to 'ON' position.

**Stopping the Unit:** Turn the Switch to 'OFF' position, unit will unload for 10 seconds prior to stopping.

#### Note:

1. Do not stop the Unit by use of a disconnect or breaker.



Using the disconnect, or breaker to stop the Unit will not allow the Unit to go through an unloading sequence, and could result in damage to the Motor, Starter, or other electrical components. Damage caused in this manner is not covered by the manufacturers Warranty.

#### **Hour Meter**

Displays the number of running hours.

#### **Power Light**

Turns on when power has been applied to the unit.



#### **Start / Stop Switch**

ON position:

Starts compressor

OFF position:

Compressor **unloads for 10 seconds** and then stops

#### **Fault Light**

Compressor fault indicator:

ON Solid = Anti-Rotation

Fast Flash = Power Interruption

Slow Flash = Service Due\*

Two Flashes = High Temp Fault

Three Flashes = Overload Fault

\*Depress 'Reset' button within cabinet to clear fault.

## Safety Precautions

In order to operate the Compressor Unit safely and correctly, we have opted to use the following symbols to make you aware of important points. These points relate to user safety and preventing equipment problems. Please pay close attention to these sections.



**Important safety Information.**  
A hazard that may cause serious injury or loss of life.



**Important information that indicates how to prevent damage to equipment, or how to avoid a situation that may cause minor injury.**



**Information that you should pay special attention to.**



The following hazards may occur during the normal use of the equipment. Please read the following chart.

<u>Area:</u>	<u>Hazard:</u>	<u>Safeguards:</u>
What to look for.	What may occur if precautions are not observed.	How to avoid the hazard.
	Tampering with the Unit while under full or partial pressure may cause an explosion.	Relieve all pressure from the Unit before attempting any repair or maintenance work.
	As the Unit starts and stops automatically, serious injury may result from working on the Compressor with the power still in the 'on' position.	Shut off all power to the Unit before attempting to repair or maintain the Compressor.
	As the Unit starts and stops automatically, do not come into contact with moving parts.	Shut off all power to the Unit before attempting to repair or maintain the Compressor.
	Air compressed by the Unit is not suitable for inhaling. It may contain vapours harmful to your health. Compressor capable of pressures >50psi	Never breath untreated compressed air produced by the Compressor. Do not direct air stream at body.
	Compressor Air End, Motor, and Tubing become hot when running. Touching these areas may cause serious burns.	Never touch the Air End, Motor, or Tubing during or immediately after operation.
	As the electrical components on the Compressor are General Purpose, there is a potential for explosion, should vapours be present in the area.	Do not install in hazardous locations. The Compressor must be a minimum of 20 feet (6.1 meters) from any source of potentially explosive vapours.

## Unpacking and Inspection

### **NOTE**

Each Champion Air Compressor is carefully tested and inspected before shipment. Though every attempt is made to ensure the safe and complete shipment of our product, freight damage or misplacement of goods may occur.

Shipments of Champion products are the property of the Consignee when the products leave our facility. Champion is not responsible for any damages or shortages caused to the product after it has left our shipping dock.

It is the responsibility of the receiver of the goods, either the Distributor or Customer, to ensure that the product has been shipped in full, and has arrived in suitable condition. Damage to the product may not be visible at time of off-loading, but may only become apparent upon unpacking or start-up.

### Some areas to initially check are as follows:

- a) Check for damage to the crating and/or packaging.
- b) Check the exterior of the Cabinet for damage, either cosmetic or mechanical.
- c) If there is mechanical damage, open the Cabinet to determine whether there is any internal damage to the Unit.

### Should there be damage to the product or shortages in shipment:

- 1) Stop any further unpacking or operation of the product.
- 2) Make note of the problem on the Freight Bill, should it concern a shortage or visible damage to the product.
- 3) Should the damage be noticed only after the product has been received, contact the transport company immediately to file a claim.  
Depending on the problem, it may be wise to photograph the damage. Also, it may be wise to discuss with the carrier representative the time allotted to give notice of loss or damage to the product; there may be guidelines which limit timeframes of same.
- 4) Do not attempt further unpacking or operation of the product. Also, do not discard any packing material used.
- 5) A Loss or Damage Claim must be submitted to the carrier and supported by the following documents:
  - Copy of Freight Bill of Lading
  - Copy of the Invoice and Estimate to repair, in case of damage
  - Damage Report
  - Copy of photos, if applicable

## Installation – Mechanical

### Moving of the Unit

When moving the Air Compressor, the forklift or hand lift forks go under the Unit from the directions as indicated.

Please be advised that care must be taken when moving and positioning the Units as they are top heavy.

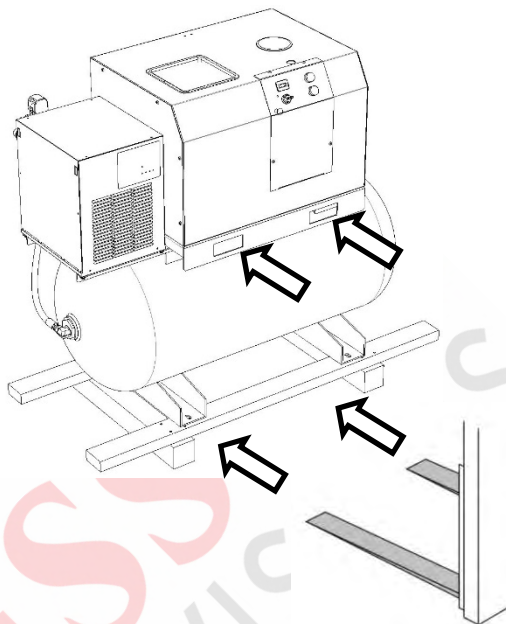

### Location of the Unit

Items to consider when installing the Unit are as follows:

- The Unit must be located indoors, in a dry, clean, cool, dust free, and well ventilated area. If possible, the Compressor should be located in a separate room or area, away from the general operations of the shop.
- Allow approximately a minimum of 18" (458mm) around and 3 feet (915mm) above the Unit for easy access to the various sides, this being for both the proper ventilation of the Unit and ease of servicing.
- Ensure that the floor under the Unit is smooth, level and capable of bearing the weight of the Compressor. The Compressor must sit squarely on the floor.
- Ensure that the Unit is anchored to the floor using isolator pads.
- If installed in a compressor room, ensure that the room is adequately ventilated. (One Horsepower produces approximately 2500 BTU/HR.)
- The ambient temperature should be between 10°C and 40°C (50°F to 104°F).

- If installing the Unit on a mezzanine, ensure that the structure can safely support the weight of the Unit. As well, the sound level of the Unit may increase due to the harmonics created by the structure; use Vibration Pads to lessen this.
- When anchoring the Unit, ensure that there is approx.. 1/4" (0.75cm) between the Nut and the Compressor Foot (as shown below). Do not bolt down tightly.

Many common Compressor problems can be attributed to the location or installation of the Unit. Make sure the Unit is in a suitable location, and installed correctly.

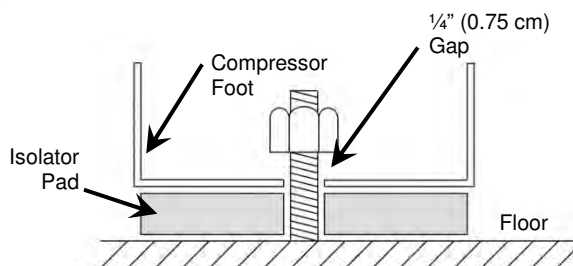

### NOTE

**The Compressor must not be operated in a confined area where the heat from the Unit cannot readily escape.**

## Installation – Mechanical (cont'd)

Shown below are items which assist in making a good installation. These are both intake and exhaust ductwork, helping the Unit to a) draw in clean outside air and b) exhaust the warmer air away from the Unit. The warmer air may be used, with the inclusion of a damper in the exhaust ducting, to warm the interior of the building during the colder months of the year.

TYPICAL DUCTING INSTALLATION LAYOUT

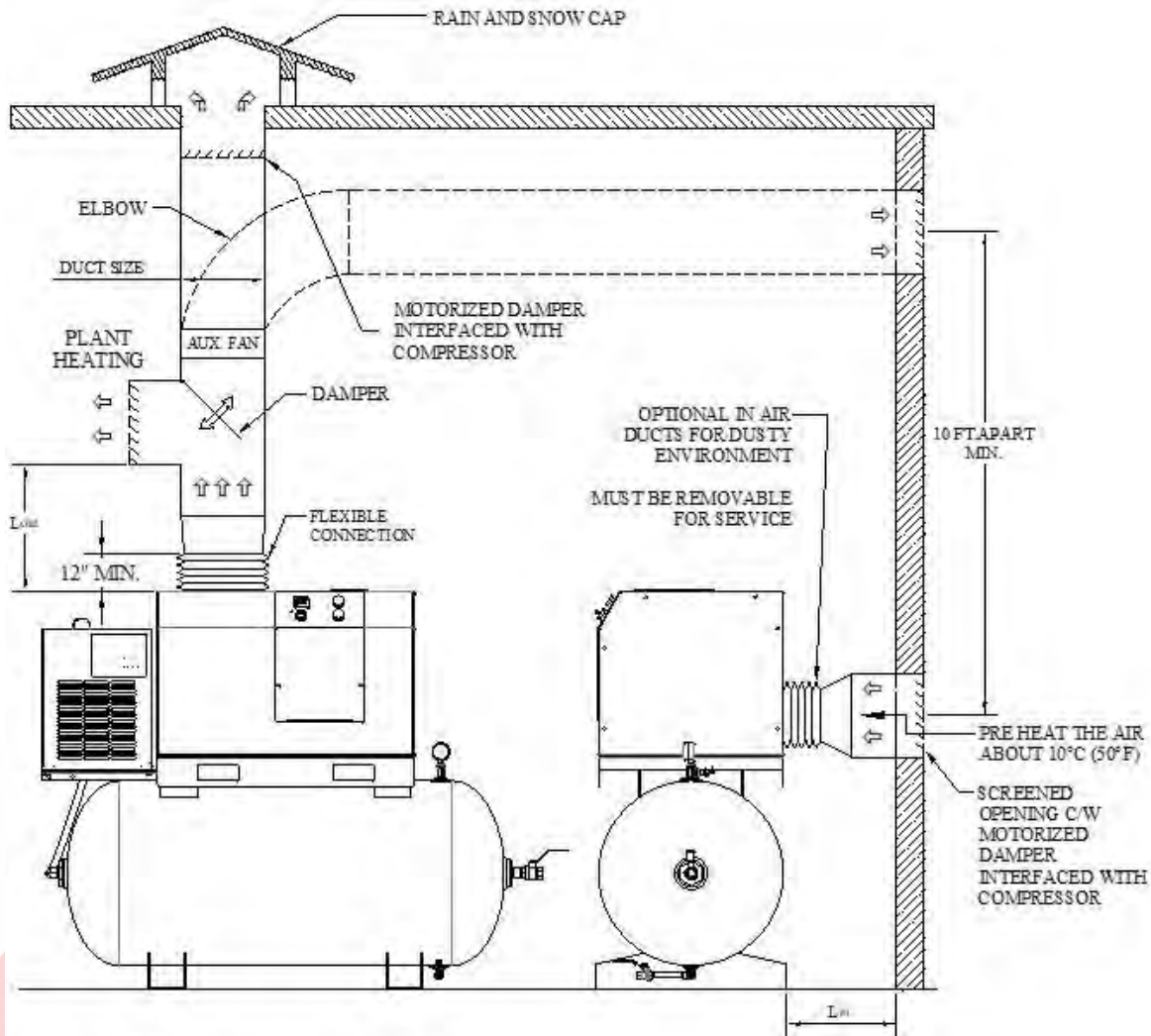

MODEL	HP	HEAT LOAD (BTU/HOUR)	COOLING AIR (CFM)	RECOMMEND MIN. DUCT SIZE	MAX. DUCT LENGTH <i>L<sub>in</sub>, L<sub>out</sub></i>	AIR OUT OPENING AT COMPRESSOR
D5	5	15,960	450	Ø 12" (CIRL.) 12" x 12" (RECT.)	3 Ft. (Aux. Fan required if >3ft.)	OUTLET SIZE 7 7/8" x 7 7/8"  INLET SIZE 10 1/2" DIA.

NOTE:

1. DUCTING SIZE BASED ON GALVANIZED STEEL DUCTS.
2. MAXIMUM PRESSURE DROP DUE TO DUCTING SYSTEM SHOULD BE WITHIN 0.1 IN. OF WATER.
3. ADDITIONAL VENTILATION SYSTEM NEEDED FOR PRESSURE DROP EXCEED ABOVE LIMIT.
4. AMBIENT TEMPERATURE: MIN. 10°C (50°F) ~ MAX. 40°C (104°F).
5. ANY DEVIATION FROM ABOVE INSTALLATION, CONSULT CHAMPION TECHNICAL SUPPORT.

## Lubrication

### Initial Start-up

Each Compressor Unit built is extensively tested at the factory before shipment. The Unit is shipped with the original oil in it as used for testing purposes.

Check the Oil level and for any Oil leaks on a daily basis. This must be done when the Unit is off. Top up the Oil level on a monthly basis.

Use only Champion lubricant. Also, do not mix the Champion lubricant with any other lubricant.

### Subsequent Oil Changes

Drain the existing oil from the Unit. (Please be advised that the Unit cannot be drained fully of oil, as some oil may remain in various components ie Cooler, Tubing, etc.)

Fill the Oil Reservoir to the top of the Oil Fill Port as shown below. Do not under or overfill. See drawing below.

Use only Champion lubricant, available in both 1 US gallon (3.8 litre) jugs or 5 US gallon (18.9 litre) pails. Any remaining oil may be used for 'top-ups'.

The 'MK-D5-CH' Maintenance Kit includes:

- (2) Oil Filter ('DSC-603-CH')
- (1) Air/Oil Separator Filter ('DSC-002832-CH')
- (2) Air Filters ('DSC-001569')
- (1) Oil Sample Kit ('308KBA6003')

This Kit should be used in the regular servicing of your Unit.

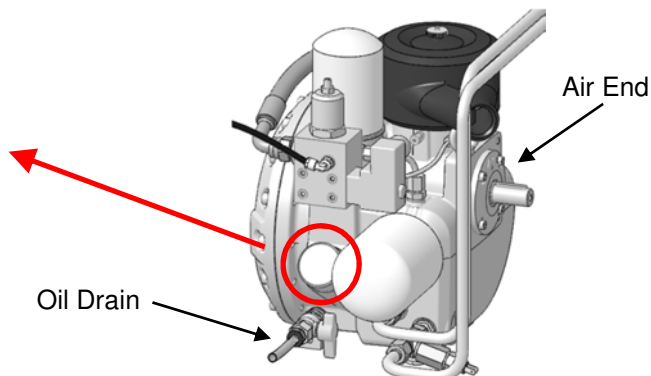
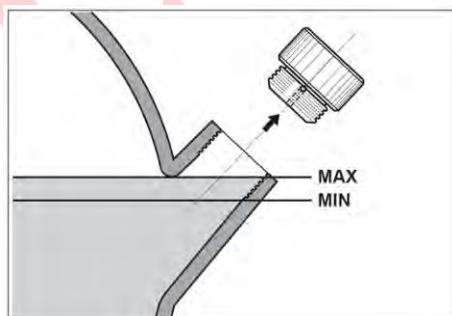

**Do not attempt to operate the Unit without first checking whether there is oil in the Air End Reservoir. Add oil as required. Serious damage may result from use, however limited, without oil.**



**Use of improper oil may negatively affect Compressor performance or shorten Unit life. Resulting problems are not covered by the Champion Air Compressor Warranty.**



**Condensation (water) may form in the Air End if the compressor work cycle experiences long pauses. If this occurs, the condensate MUST be drained EVERY 50HRS OR WEEKLY:**

- Wait for compressor to cool for approx. 2HRS.
- Remove service panel
- Slowly open the oil drain valve on the air end & drain condensate
- When the first traces of oil appear, close the cap/valve
- Top up the Air End with new oil using only Champion lubricant.



## Installation - Electrical

### General Information

It is your responsibility to ensure that the Compressor Unit is electrically connected in a safe and correct manner. **Any electrical work should be carried out by a competent Electrician, and be done in such a way that it meets all applicable Codes and Regulations.**

Ensure that a suitable Fused Disconnect or Breaker is installed in the electrical supply before the Compressor Unit.

Ensure that a suitable Fused Disconnect or Breaker is sized and installed according to the appropriate local electrical codes.

Electrical wiring and conduit from the building supply, through the Compressor Cabinet, and to the Switch in the Compressor Control Panel, must be rated for 90°C (194°F) or higher.

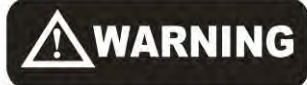

- Failure to correctly connect the Compressor to your building's electrical services may result in serious personal injury or damage to the equipment.
- Install all covers and panels before applying power to the Unit.
- Failure to install proper fuse protection may void the unit warranty
- Before servicing the Unit, ensure the power source has been shut down and locked off.
- Read and understand the information contained in this manual before installing or operating the Unit.
- This product must be connected to a grounded, metallic, permanent wiring system, or an equipment-grounding terminal or lead on the product.

**Failure to observe any of the above precautions could result in severe personal injury or death, and/or damage to the Unit.**

### Wiring Practices

When making power and control wiring connections, please observe the following precautions:

- Ensure that all wiring, fusing, etc is done in a manner that meets with the appropriate codes and regulations.
- See the sales drawing and electrical schematic contained in this booklet for Unit amp draw, as well as Unit fuse sizes and overload settings.
- A licensed Electrician is to determine the appropriate Disconnect/Breaker and wiring sizes based on the Unit amp draw and the appropriate Electrical Code.

#### Fixed Speed Units:

**Use TIME-DELAY type fuse.**

**Max. Allowable Fuse = 1.75 x Motor Full Load Amp**

## Installation – Electrical (cont'd)

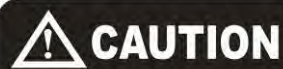

Do not attempt to operate the Unit without first checking whether there is oil in the Air End Reservoir. Add oil as required. Serious damage may result from use, however limited, without oil.

### Electrical Connection

The Electrician is to bring power to the Unit through the 3/4" conduit hole located on the top of the unit. The Electrical Panel is accessible by means of opening the Front Control Panel Cover.

Connect ground wire to Protective Earth terminal. Bring power to L1 and L2. See page 12 for start-up procedures

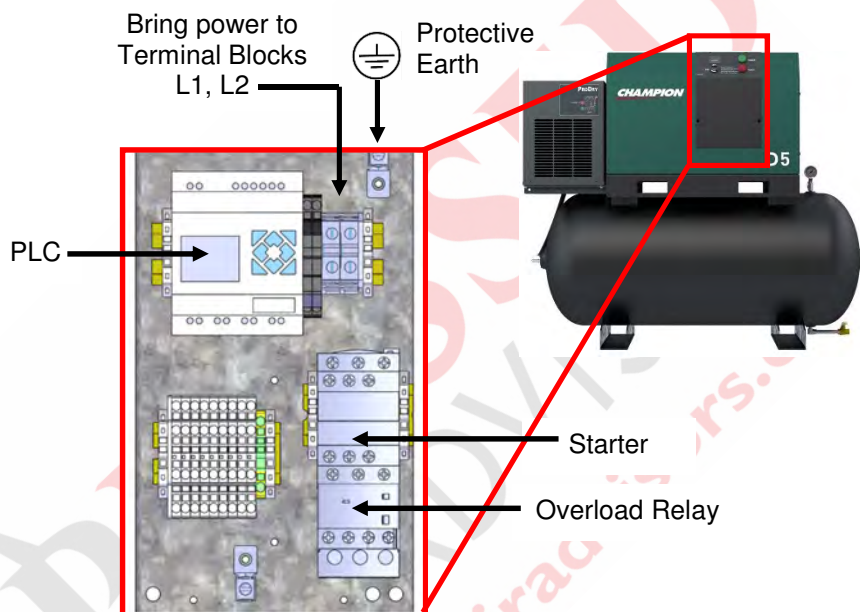

### Motors

Wiring must be done in a manner that 230 volts +/- 5% is available at the Motor terminals during start-up. Contact your local Distributor or Service Centre if additional information is needed.

The Warranty that exists on the Electric Motor is that of the original manufacturer. In the event of a Motor failure, locate a certified EISA motor service centre.

### Motor/Air End Rotation

It is critical that the Motor and Air End in the Rotary Screw Unit be turning in the correct manner. Irreparable damage will be done if the Unit rotates in the opposite direction. The correct rotation is shown at right.

The Unit is equipped with an Anti-Rotation Switch. If the Unit will not start and an 'Anti Rotation' error is noted on the Controller, change the connections at the motor connection box to the following:

- Motor L#1 & Motor L#5 with Harness Black
- Motor L#4 & Motor L#8 with Harness White

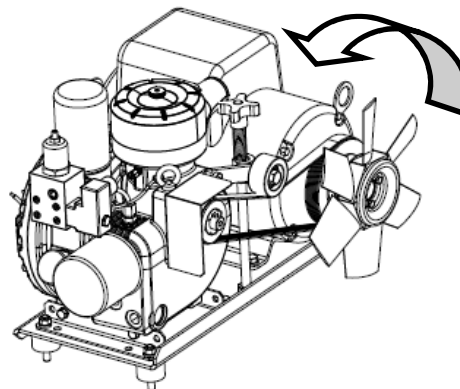

## Motor Maintenance Instructions

### Cleaning

To ensure that the Motor operates at optimum temperatures and provides years of trouble-free service, periodically clean the outside of the Motor Housing of any build-up of dust, etc. Though it is not anticipated that, if installed correctly and in a suitable environment, there should not be much build-up on the Motor, keeping the Housing clean will allow the Motor to operate more efficiently.

### Lubrication

This is a ball bearing motor. The bearings have been lubricated at the factory. Motors that do not have regrease capability are factory lubricated for the normal life of the bearings.

Noted below is a chart outlining the interval at which the Motor should be lubricated, this is based on the Motor horsepower. This must be part of a regular maintenance schedule.

Motor HP	Interval in Hours	Weight of Grease		Volume of Grease	
		Ounces	Grams	Cubic Inch	Teaspoon
5	12,000	0.3	8.4	0.6	2.0

The above chart is based on a standard environment in which the Motor is operating of 40°C. For other conditions, please multiply the Hour Interval from the chart above by the factor as indicated below.

Severity of Duty	Factor	Environmental Conditions
Standard	1.0	40°C (104°F), clean, little corrosion
Severe	0.5	50°C(122°F), moderate dirt, corrosion
Extreme	0.1	> 50°C (122°F), severe dirt, abrasive dust
Low Temperature	1.0	< 30°C (86°F)

### Lubricant

Motors are pre-greased, normally with Exxon Mobil Polyrex EM. Equivalent and compatible grease is Chevron SRI #2.

## Start-up Procedures

### Unit Controls

#### **Start/Stop Switch**

Start position:  
allows the Unit to start.

Stop position:  
unit will shutdown after 10 secs.



### Initial Start-up

- 1) Remove the RH Side Access Panel, and ensure that there is sufficient Oil in the Air End. Refer to the 'Lubrication' section (page 8) in this manual for proper type and level of Oil.
- 2) Do a visual inspection of the Unit, and ensure that no internal damage was caused during transit.
- 3) Place the Fused Disconnect or Breaker in the 'On' Position. Check that there is power to the Controller, the green Power light will be on.
- 4) During normal operation of the Unit, keep the Access Panels closed at all times. As well, do not place any obstructions against or on top of the Unit, thereby limiting the flow of cooling air.
- 5) Ensure the Ball Valve on the Unit is closed, turn the Selector Switch to the 'On' position, and run the Unit up to maximum pressure. The Unit will run up to 145 psi (10bar), at which point the Motor will continue to run but not compress air.
- 6) Once the Unit reaches 145 psi (10bar), it will idle for 1 minute and shut off.  
  
Default Offload Time of this unit is 1 minute. It would switch from 1 minute to 3 minutes if rate of pressure decay is high.
- 7) Open the Ball Valve slightly and allow the air to bleed from the Tank. Once the pressure reaches approx. 110 psi (7.6bar), the Unit will start and begin to compress air after a short delay.
- 8) Measure the amp draw when the Unit reaches the maximum pressure of 145 psi (10bar).
- 9) Close the Ball Valve, allow the Unit to reach maximum pressure, idle, and shut off.
- 10) The Unit is ready for normal use.
- 11) To validate Warranty, complete the warranty registration and attach to the on-line startup claim within Thirty (30) days of initial operation, or email to:  
**'gdservice@gardnerdenver.com'**

### **CAUTION**

**Do not place any materials in close proximity to the Compressor. Placing materials against or close to the Unit will limit the cooling required, and could lead to premature failure.**

### **WARNING**

**Shut off all power to the Air Compressor Unit before attempting any repair or maintenance.**

### **NOTE**

**Adjusting the settings of the Controller could adversely affect the performance of the Unit. Only those individuals with knowledge of the Unit should make any adjustments.**

## Preventative Maintenance Schedule



**When servicing the Air Compressor, shut off all power to the Unit, and drain it of air pressure.**



**It is the responsibility of the compressor owner to ensure that a regular Maintenance Schedule is followed.**

Noted on the following pages are general Maintenance guidelines based on average working conditions. Should the Unit be worked under extreme conditions, please contact your Champion Distributor for further input. As well, all maintenance/service work must be carried out by a qualified Technician.

The typical operating temperature of the Unit, this dependant on ambient temperatures, is between 70°C and 85°C (158°F and 185°F).

If the operating temperature of the Unit is too low (less than 70°C (158°F)):

- condensation will build up in the system and mix with the oil, causing internal component problems in the Unit
- Change the ambient conditions to increase the operating temperature.

If the operating temperature of the Unit is too high (above 85°C (185°F)):

- the oil will oxidize and lose it's properties, this causing internal damage to components as well
- to combat this, the oil must be changed more often than noted below.

**Note: Participation in Champion's oil analysis sampling program is required to receive the extended warranty. Any recommendations detailed in the oil analysis report must be followed as outlined in the report.**

### Regular Maintenance Items

<b>'MK-D5-CH'</b>	<b>4000 Hour Maintenance Kit</b>
(2) <b>DSC-603-CH</b>	Oil filter
(1) <b>DSC-002832-CH</b>	Air/Oil Separator Filter
(2) <b>DSC-001569</b>	Air Filter
(1) <b>308KBA6003</b>	Oil Sample Kit

### Lubricant Options

Champion offers various lubricants for your unit, available in quantities of 5 US Gal. (18.9 litre) pails:

RotorLub 8000  
RotorLub 8000TH  
RotorLub 4000  
RotorLub 4000FG  
RotorLub 4000FG-68

### Internal Access for Maintenance

The internal components of the Unit are accessible for servicing by way of removing the RH Side Panel.

The Back Panel is also removable to access the Belts.

Remove the plastic cap to change air/oil separator filter.

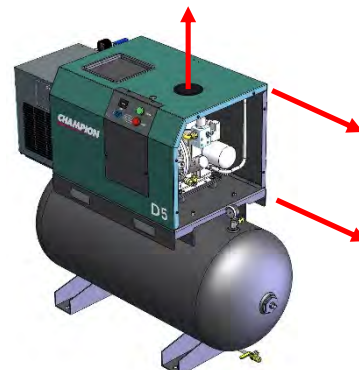

## Preventative Maintenance Schedule (cont'd)

Maintenance Item:	Daily	Maintenance Interval (in 000's of Hours)																			
		2	4	6	8	10	12	14	16	18	20	22	24	26	28	30	32	34	36	38	40
<b>Compressor Room</b>		Ambient Temperature should be between 10°C and 40°C (50°F and 104°F)																			
Temperature	Inspect																				
Cleanliness	Inspect																				
<b>Air Compressor Unit</b>																					
Check Oil Level	Inspect																				
Take Oil Sample (See Note a)		X	X	X	X	X	X	X	X	X	X	X	X	X	X	X	X	X	X	X	X
Replace Oil (See Note b)	(1)		X		X		X		X		X		X		X		X		X		X
Replace Oil Filter	(2)	X	X	X	X	X	X	X	X	X	X	X	X	X	X	X	X	X	X	X	X
Replace Air / Oil Separator	(3)		X		X		X		X		X		X		X		X		X		X
Replace Air Intake Filter	(4)	X	X	X	X	X	X	X	X	X	X	X	X	X	X	X	X	X	X	X	X
Replace Belt	(5)				X				X				X				X				X
Replace Tank Relief Valve							X						X						X		
Replace Solenoid	(6)				X				X				X				X				X
Rebuild Intake Valve	(7)				X				X				X				X				X
Rebuild Thermo Valve	(8)			X			X			X			X			X			X		
Rebuild Minimum Pressure Valve	(9)				X				X				X			X			X		
Motor Bearing Lubrication		Refer to Motor Manufacturer's Recommendations																			

- Notes:**
- Participation in Champion's oil analysis sampling program is required to receive the extended warranty. An oil sample must be sent to our lubricant analysis laboratory **every 2000 hours or every 6 months**, whichever occurs first. Any recommendations detailed in the oil analysis report must be followed as outlined in the report. Oil sample bottles are to be obtained from your local authorized Champion distributor.
  - The Champion oil used in the maintenance schedule is rated as a 4000 hour oil. A complete Oil change must be done every 4000 hours of Unit operation, **or every 12 months**, whichever occurs first. If other champion lubricant is used, please refer to the Warranty on Page 33 for further information.
  - If a component, during a regular inspection, has proven to be defective or unfit for regular operation, it must be repaired or replaced.

Parts and Repair Kits based on the above chart are as follows:

- |     |                             |  |
|-----|-----------------------------|--|
| (1) | RotorLub 4000 oil:          | 28H116   |
| (2) | Oil Filter:                 | DSC-603-CH   |
| (3) | Air / Oil Separator:        | DSC-002832-CH  |
| (4) | Air Intake Filter:          | DSC-001569   |
| (5) | Belt (1):                   | DSC-002820   |
| (6) | Solenoid with Cable:        | DSC-002885 (up to AE S/N SC272839)<br>DSC-002957 (above AE S/N SC272839) |
| (7) | Intake Valve Repair Kit     | DSC-001712   |
| (8) | Thermo Valve Repair Kit:    | DSC-002057   |
| (9) | Minimum Pressure Valve Kit: | DSC-001713   |
|     | Shaft Seal Kit              | DSC-002835   |

As noted previously, the 'MK-D5-CH' Maintenance Kit includes the following items:

- |     |                      |                          |
|-----|----------------------|--------------------------|
| (2) | <b>DSC-603-CH</b>    | Oil Filter               |
| (1) | <b>DSC-002832-CH</b> | Air/Oil Separator Filter |
| (2) | <b>DSC-001569</b>    | Air Filter               |
| (1) | <b>308KBA6003</b>    | Oil Sample Kit           |

## Maintenance Procedures

### Changing the Air Intake Filter

- 1) Remove the Nut holding the Top half of the Housing and then remove the Top.
- 2) Remove the Air Filter Element from the Unit.
- 3) Clean the Intake Valve area of any dust or build-up.
- 4) Install a new Air Filter (Champion Part Number 'DSC-001569'), place the Element Top on the Filter, and fasten down with the Wing Nuts.

**Note:**

Depending on the quality of the air in the compressor room, it may be necessary to check and/or change the Air Filter more often than indicated on the 'Maintenance Schedule'.

### Changing the Air / Oil Separator

- 1) If necessary, use a strap wrench to turn the original Separator counter-clockwise.
- 2) On the new 'DSC-002832-CH' Air / Oil Separator, lubricate the Separator Gasket with Compressor Oil.
- 3) Hand tighten the new Air / Oil Separator snug

**Note:**

Do not over-tighten the Separator Filter on the Unit, as it may become very difficult to remove at a later date.

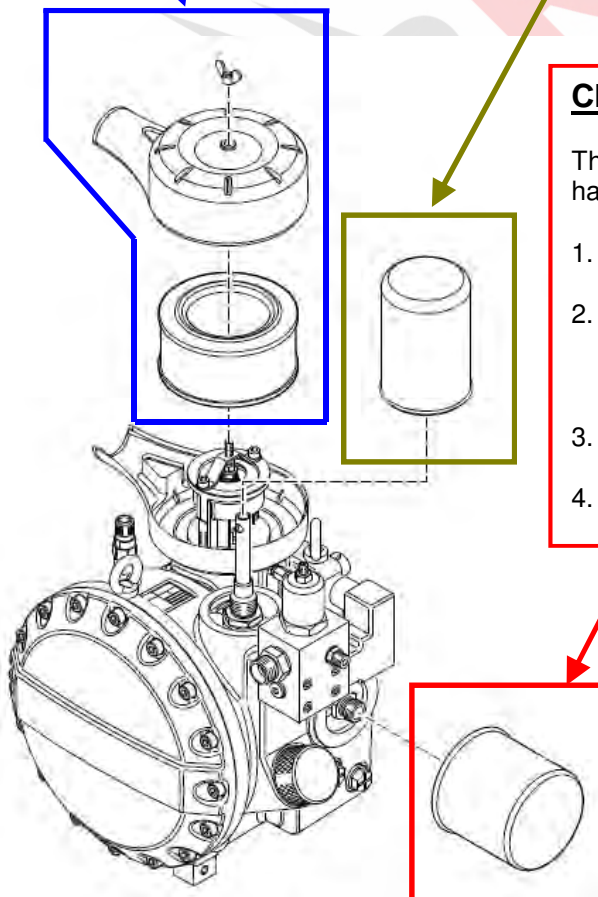

### Changing the Oil Filter

The Oil Filter should be changed only after all of the oil has been drained from the Unit.

1. Ensure that you have a bucket and strap wrench available.
2. Holding the bucket under the original Oil Filter to capture any spillage, use the strap wrench to turn the Oil Filter counter-clockwise. The Oil may still contain oil, so care must be taken.
3. On the replacement 'DSC-603-CH' Oil Filter, lubricate the Filter Gasket with Compressor Oil.
4. Hand tighten the Oil Filter snug.

## Maintenance Procedures (cont'd)

### Cleaning the Heat Exchanger

The circulation of air through the Heat Exchanger is critical to the correct operation of the Unit. Clean the Heat Exchanger on a regular basis.

1. Remove the Back Panel.
2. Vacuum the Heat Exchanger as necessary.

#### **Note:**

When cleaning the Heat Exchanger, do not use sharp objects or a wire brush. These items could damage the cooling coils.

Heat Exchanger

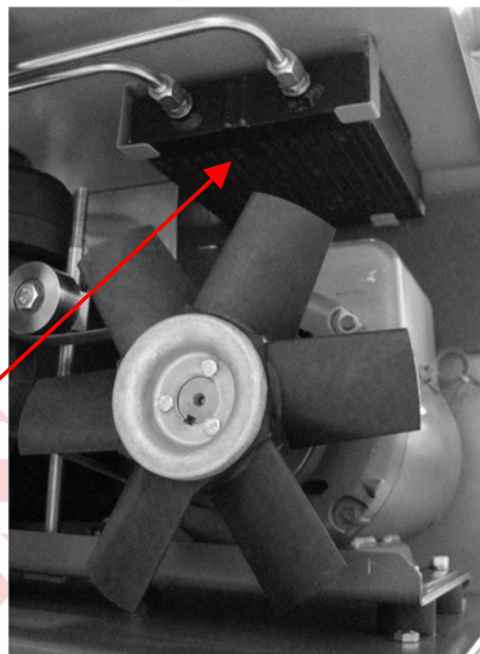

### Oil Changes

Drain the existing oil by turning the Oil Drain Tube down and opening the Valve. (Please be advised that the Unit cannot be drained fully of oil, as some oil may remain in various components ie Cooler, Tubing, etc.)

Close the Drain Valve.

Fill the Oil Reservoir to the top of the Oil Fill Port as shown below. Do not under or overfill. See drawing below.

Use only Champion lubricant.

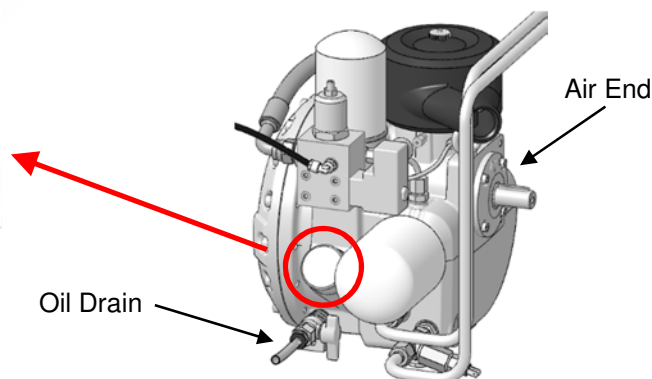
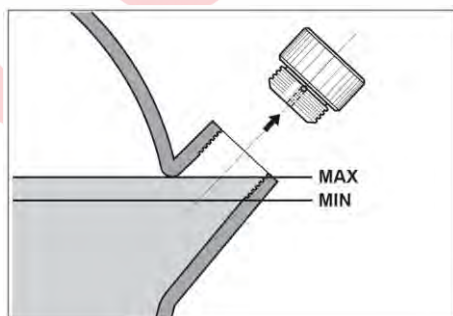



## Maintenance Procedures (cont'd)

### Adjusting the Drive Belts

This unit is equipped with a Belt Tensioning Device that constantly maintains the proper drive tension for the Belt. The loosening and tightening of the Drive Belt is done by way of moving the Belt Tensioning Roller up or down on the belt, respectively.

To loosen the belt tension, simply turn the Hand Wheel counter-clockwise. This will allow the Belt Tensioning Roller to lift off of the Belt.

To tighten the belt tension, simply turn the Hand Wheel clockwise. This will compress the Tension Spring and push the Belt Tensioning Roller down further onto the Belt.

Note: The Belts (new) should be tensioned as follows:

HP	Deflection	Frequency	
		New	After Run
5	10mm deflection with 40N at centre span  (.39" with 9 Lb Force)	96 Hz	93 Hz

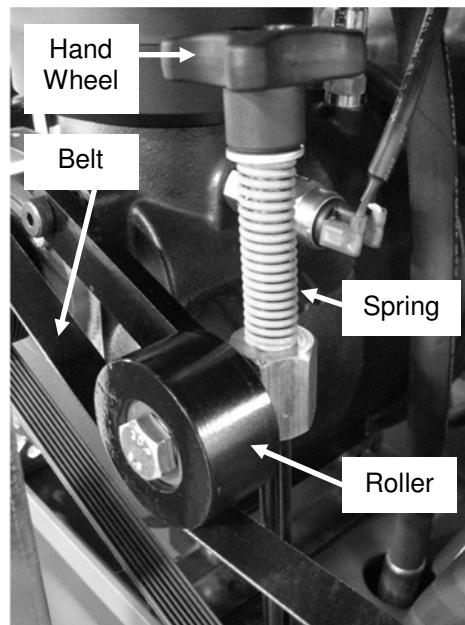

### Using a Frequency Analyzer

After the belts have been installed it is recommended that the belt tension be set to a frequency listed in the above table. To obtain the correct frequency the use of a Frequency Analyzer 'FA-9000' is recommended.

1. Place the belts over the air end and motor pulleys.
2. Place the Roller onto the belt as shown above.
3. Turn the Hand Wheel clock-wise to tighten the spring and push the Roller onto the Belt.
4. Check the frequency of the Belt with the Frequency Analyzer:
  - a. Place the microphone of the Frequency Analyzer close to the Belt
  - b. Push the 'On' button
  - c. Pluck the belt
  - d. The Frequency Analyzer will make a tone and the frequency will displayed on the screen
5. Adjust the Spring as required repeating steps 3 & 4.



## Maintenance Procedures (cont'd)

### Intake Valve Repair Kit

The Intake Valve Assembly is located directly below the Intake Filter, and should be rebuilt after a maximum of 10,000 hours of Unit operation. Please order (1) 'DSC-001712 Intake Valve Repair Kit. Shown below are the various components associated with the Intake Valve Repair Kit.

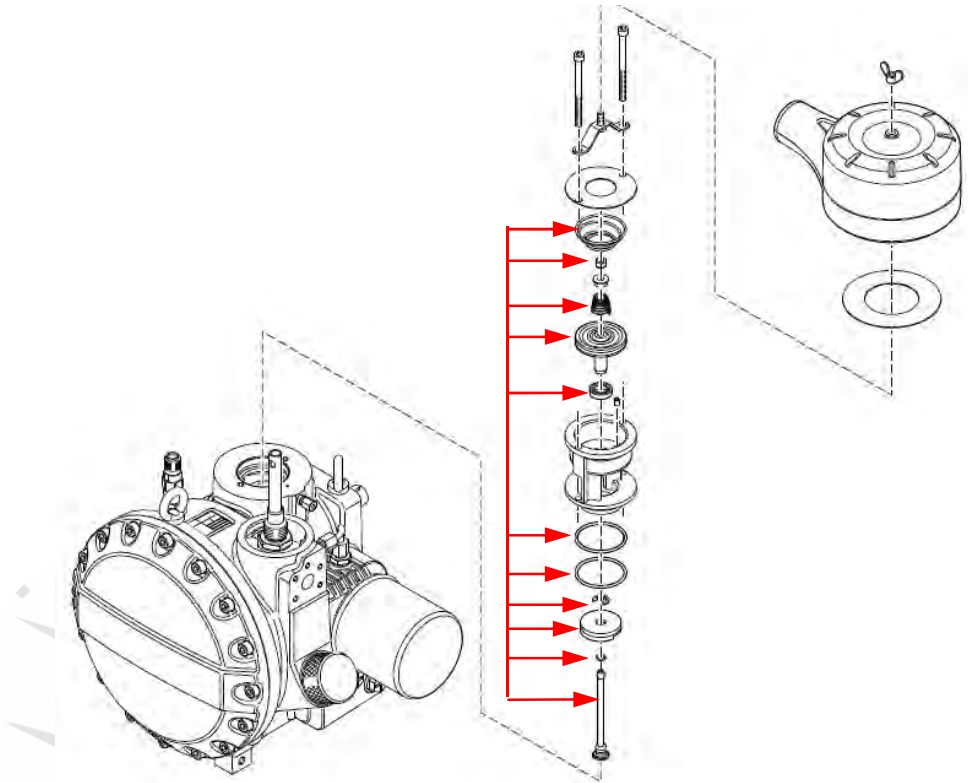

Intake Valve Open

Intake Valve Closed

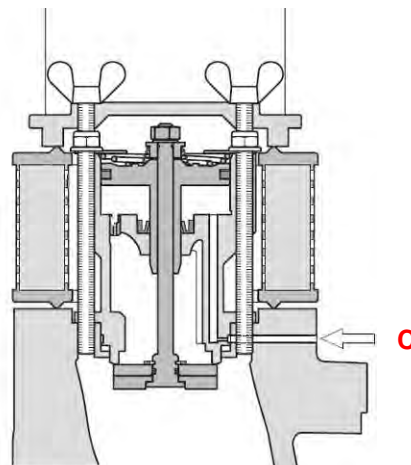
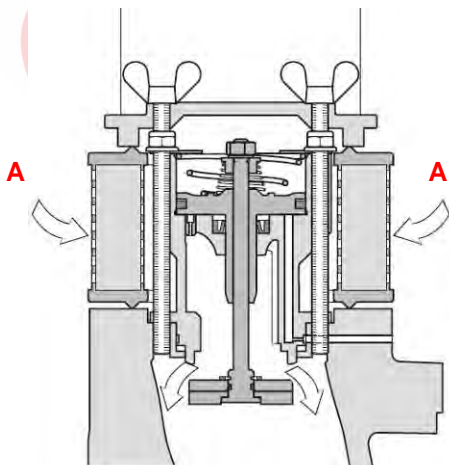

- A: Air Inlet
- B: Air Outlet
- C: Control Line of Intake Valve

## Maintenance Procedures (cont'd)

### Thermo Valve Repair Kit

The Thermostatic Valve Assembly is located at the back of the Air End and to the bottom left of the pulley, and should be rebuilt after a maximum of 6,000 hours of Unit operation.

Please order (1) 'DSC-002057' Thermo Valve Repair Kit

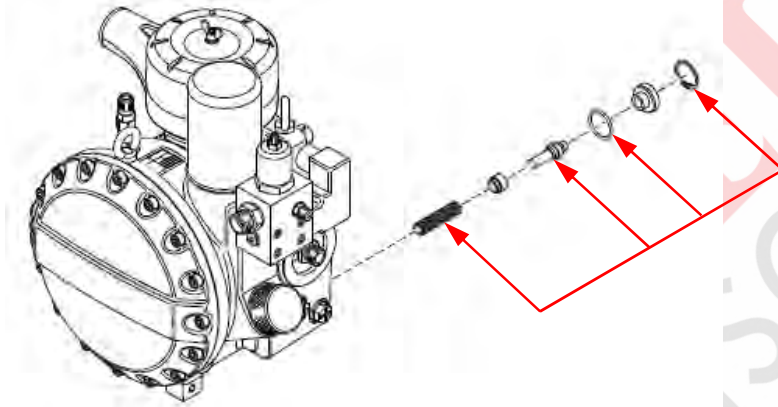

### Thermo Valve Operation

The Thermostatic Valve Assembly helps to maintain an optimum oil temperature in the Unit, allowing the hotter oil (once the Unit reaches operating temperature) to flow through the Heat Exchanger.

This is as indicated below.

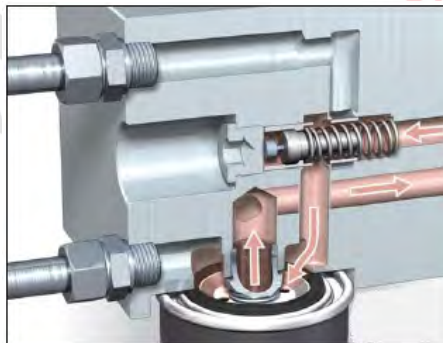

**When Oil is Cool at Start-up.**

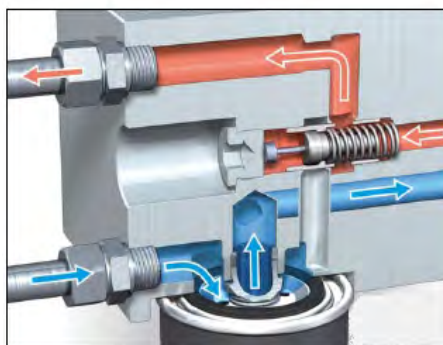

Hot Oil to Heat Exchanger  
Cool Oil from Heat Exchanger

**As Unit Reaches Operating Temperature.**

## Maintenance Procedures (cont'd)

### Minimum Pressure Valve Repair Kit

The Minimum Pressure Valve is located beside the Air Oil Separator, and a) acts to ensure there is a back-pressure of approx. 80 psi (5.5bar) to provide sufficient lubrication in the Air End and b) acts to stop compressed air from flowing backwards i.e. as a one-way Valve. Please order (1) 'DSC-001713' Minimum Pressure Valve Repair Kit.

Shown at right are the various components included in the Kit.

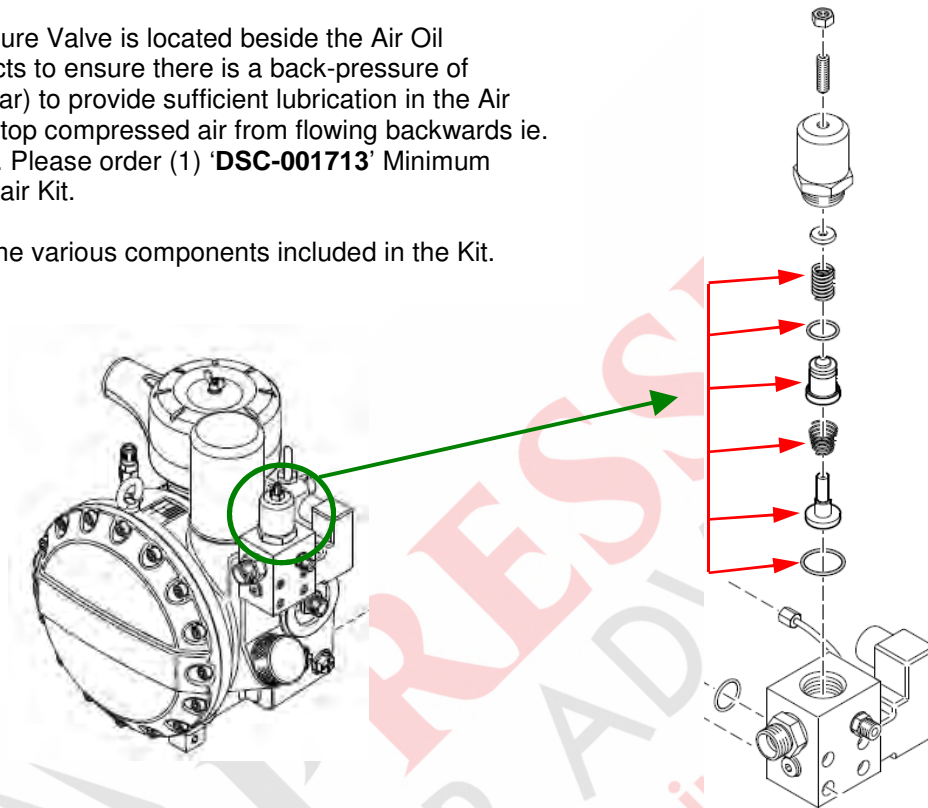

### Shaft Seal Kit

Please order (1) 'DSC-002835' Shaft Seal Kit. Shown below are the various components included in the Kit.

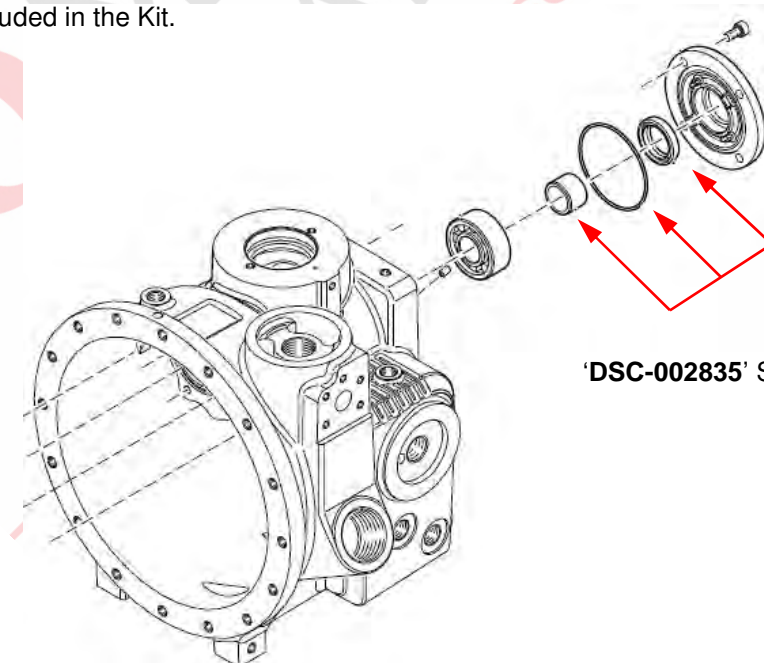

'DSC-002835' Shaft Seal Kit

## Maintenance Procedures (cont'd)

### Temperature Switch

The Temperature Switch is located below the Oil Filter in the tee of the Oil Tube going to the Cooler. The Temperature Switch reads the oil temperature of the unit. If the oil temperature reaches 105°C (220°F) the unit will shut down, please refer to Page 26 for corrective action

To replace the Switch, please order 'DSC-002801'.



### Anti-Rotation Switch

The Anti-Rotation Switch is set to send an error to the PLC once the pressure read at the Switch has reached approx. 8 psi and the unit will shut down. This prevents the Air End from rotating in the wrong direction. Please refer to Page 26 for corrective action.

The Anti-Rotation Switch is located on the Motor side of the Air End. To replace the Switch, please order 'DSC-102'.

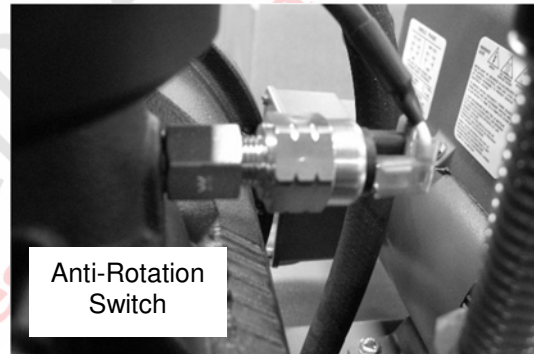

## 'CSC15' Controller

Shown below is the 'CSC15' Controller which regulates the operation of the Unit. Unit status LEDs, Hour Meter, and ON / OFF switch are located on the control panel cover.

**Note:**

1. Do not stop the Unit by use of a disconnect or breaker.

### **NOTE**

Using the disconnect, or breaker to stop the Unit will not allow the Unit to go through an unloading sequence, and could result in damage to the Motor, Starter, or other electrical components. Damage caused in this manner is not covered by the manufacturer's Warranty.

#### Hour Meter

Displays the number of running hours.

#### Power Light

Turns on when power has been applied to the unit.



#### Start / Stop Switch

ON position:  
Starts compressor  
OFF position:  
Compressor **unloads for 10 seconds** and then stops

#### Fault Light

Compressor fault indicator:  
ON Solid = Anti-Rotation  
Fast Flash = Power Interruption  
Two Flashes = Service Due\*  
Three Flashes = Overload Fault  
\*Depress 'Reset' button within cabinet to clear fault.

## 'CSC15' Controller (cont'd)

### Controller Interface

A PLC is programmed to monitor and enables various functions of the compressor. It is accessed by way of removing the control panel cover.

The Operator Interface for the PLC is shown below.

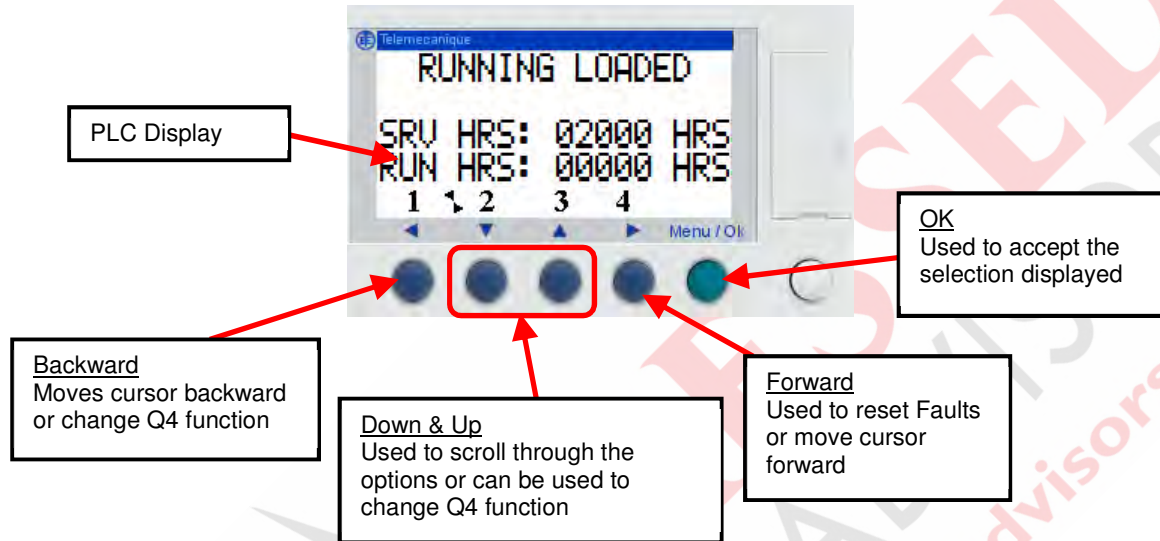

### **WARNING**

Shut off all power to the Air Compressor Unit before attempting any repair or maintenance. Control panel voltage is 230Vac. Hazardous voltage cause severe injury or death.

### Controller Display

It provides information regarding both the operation and service of the Unit.

1. Unit Status
2. Running hours and the remaining service hours

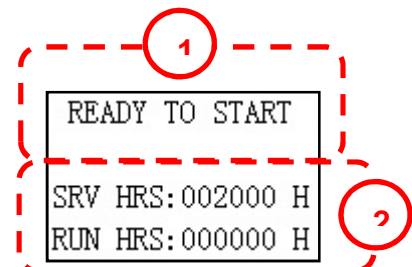

**'CSC15' Controller (cont'd)****Unit Standard Operating Parameters**

The chart below indicates the standard operating parameters programmed into the D5's Programmable Logic Controller at the factory.

Model	Load Pressure	Offload Pressure	Load Delay (seconds)	Idle Shutdown (minute(s))	Blowdown Time (seconds)	Service Due Hours
D5	110 psi	145 psi	5	1*	60	2000

A description of the terminology used in the above chart is as follows:

**Load Pressure:** The pressure at which the Unit will begin to compress air.

**Offload Pressure:** The pressure at which the Unit will stop compressing air.

**Load Delay:** The amount of time the Unit will idle before it compresses air when ON/OFF switch is switched from 'OFF' position to 'ON' position.

**Idle Shutdown:** The amount of time the Unit will idle (run but not compress air) after it has reached the Unload Pressure before shutting off. The default idle shutdown is 1 minute. CSC15 continuously monitor rate of pressure decay and change idling time accordingly to save energy consumption.

Idle Shutdown Timer = 1 minute (if rate of pressure decay is slow)

Idle Shutdown Timer = 3 minutes (if rate of pressure decay is high)

**Blowdown Time:** The period of time required to discharge pressure from the air end when the Unit stops after idle shutdown.

**Service Due Hours:** The maximum allowable time between regular maintenance/service of the Unit.

 **NOTE**

The above chart is supplied for information only. Serious consequences could result should any of the parameters be adjusted by someone who is not familiar with the correct and safe operation of the Unit.

Any adjustments made to the above parameters by others (other than a qualified Technician) resulting in the incorrect operation of the Unit, damage to the Unit, or damage to property is not covered by the Champion Warranty.

Please consult with your Champion Distributor or contact Champion directly should you have any questions or concerns about any of the information in the chart above, or in this manual.



## 'CSC15' Controller (cont'd)

### Typical Operating Display

Typical information shown on the display is presented below.

Unit has power to it, but the Switch is in the 'OFF' position and the Unit is ready to start.

READY TO START
SRV HRS: 002000 H
RUN HRS: 000000 H

When the Switch is switched to 'ON' position, the Unit will idle for 5 seconds before it begins to compress air.

RUNNING UNLOADED
LOAD DELAY
SRV HRS: 002000 H
RUN HRS: 000000 H

After the Unit has idled for 5 seconds, the Unit will begin compressing air.

RUNNING LOADED
SRV HRS: 002000 H
RUN HRS: 000000 H

Once the Unit has reached the maximum pressure of 145 psi, it will remain running, but will be in an Idle mode for 1 or 3 minutes depending on rate of pressure decay, it will not compress air.

RUNNING UNLOADED
IDLE T: 000178 S
SRV HRS: 002000 H
RUN HRS: 000000 H

After the Unit runs in the unload state, the Unit will shut down and it relieves pressure in the air end for 60 seconds. Once this blowdown time of 60 seconds expires and if there is an air demand, the Unit will start again.

STANDBY ACTIVE
SRV HRS: 002000 H
RUN HRS: 000000 H

After 2000 hours of running, "Service Due" message will appear on the display. This indicates that the Unit requires service. Please refer to the Maintenance Schedule on page 14 of this manual for the required service.

SERVICE DUE
SRV HRS: 000000 H
RUN HRS: 002006 H

### Resetting the Service Alarm

The D5 compressor must be serviced every 2000 hours. The Controller is programmed to count down from 2000 hours to 0 hours. Once it reaches 0 hours, the Red LED light on the control panel cover flashes in slow frequency and an error message appears on the Controller screen, this indicating that service is due.

Once the servicing of the Unit has been completed, the Timer must be reset to 2000 hours.

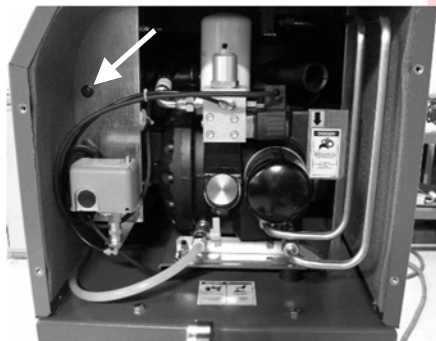

1. Turn the Compressor off by turning the On/Off Switch to the 'OFF' position.
2. Remove the service door on the right-hand side of the unit.
3. Press the 'Service Reset' button, the arrow on the left shows the location of the Service Reset button,.
4. Turn the Compressor on by turning the On/Off Switch to the 'ON' position
5. Verify that the alarm has been cleared & the Fault Light is no longer flashing.
6. Replace the service door.

## Common Compressor Faults

### Common Faults

Noted below are the most common Faults experienced.

#### 'CSC15' Alarms

There is an issue with the Unit, but it will still operate.

<b>Indication:</b>	<b>Description:</b>	<b>Most Common Items to Check:</b>
 [ Slow flash]	Service Due	Service unit (please refer to Preventative Maintenance Schedule on pg. 13)

#### 'CSC15' Shutdown Errors

There is an issue with the Unit and the Unit will not operate until the Fault has been addressed.

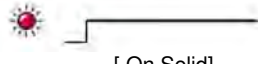
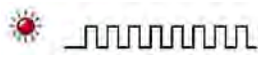
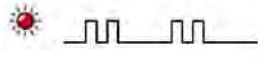
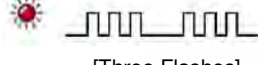
<b>Indication:</b>	<b>Description:</b>	<b>Most Common Items to Check:</b>
 [ On Solid]	Anti-Rotation	Rotation of Motor wrong, Solenoid Valve not relieving pressure, Intake Valve Orifice clogged
 [Fast Flash]	Power Interruption	Power failure occurred, power was interrupted before Unit completed its Stop Sequence
 [Two Flashes]	Excessive Temperature	Ambient temp high, Unit dirty, low oil level, no air flow through Cooler, Temperature Switch defective
 [Three Flashes]	Motor Overload	Motor drawing high amps, low voltage, higher pressure settings, low oil level, loose wires

## Separator Filter and Refrigerated Air Dryer

Your Unit may be equipped with a Separator Filter and an 'ASD15' Refrigerated Air Dryer Unit as indicated below. These items are located in the compressed air lines after the air is compressed and after the Air Receiver.

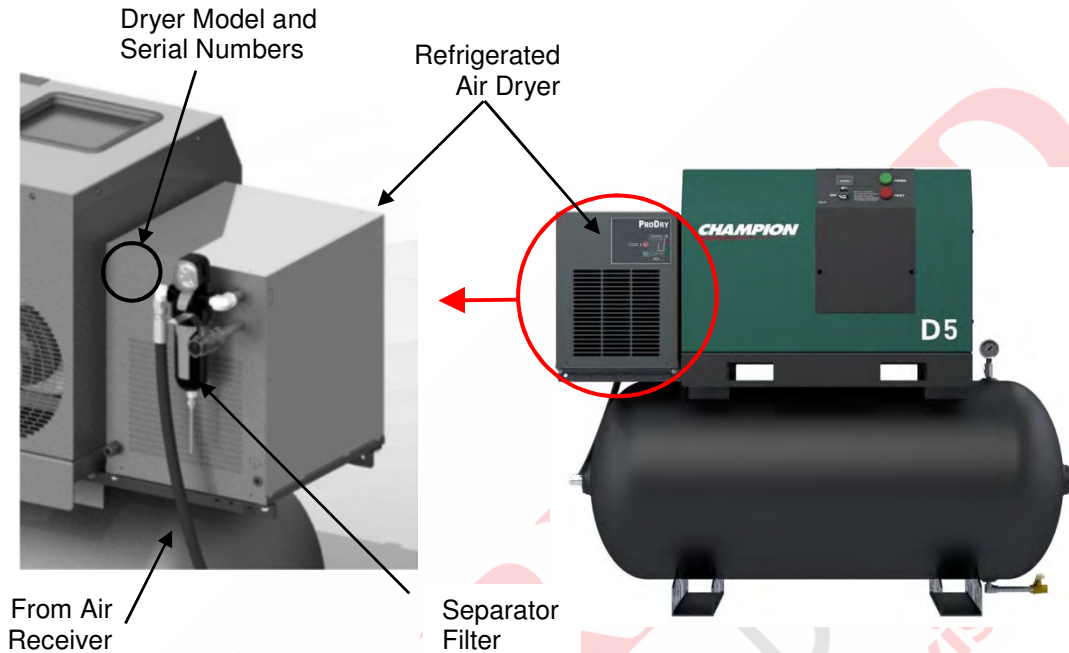

More detailed information concerning the Dryer Unit is included in the Dryer manual. The information contained in this manual is a 'quick reference' only.

### Dryer Controls

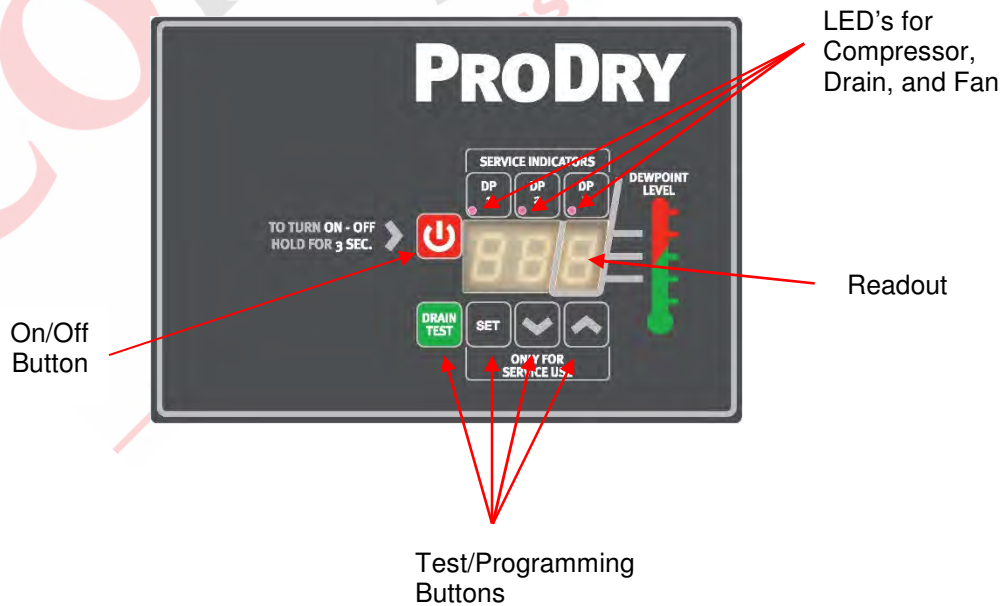

## Separator Filter and Refrigerated Air Dryer (cont'd)

### Typical Dryer Operation

The Dryer will operate as follows:

- Pressing the 'On/Off' Button for 3 seconds will start the Unit
- There is a time delay of up to 2 minutes before the Refrigerant Compressor starts.
- The Condenser Fan will start approx. 30 seconds there-after.
- The Fan will not normally run at full speed, this indicated by a flashing LED
- The readout will initially show ambient temperature indicated by 3 horizontal bars on the readout
- Once the Fan and Compressor start, the dew point of the Unit will decrease to approx. 1°C, this indicated by 1 horizontal bar.
- Once at approx. 1°C, the Fan will stop, only to be called to run again once the temperature increases to approx. 5°C
- Pressing the 'On/Off' Button (when the Unit is operating) will run the Fan at full speed for several seconds, after which the Unit will stop. (The LED will be on continually while the Fan runs at full speed.)

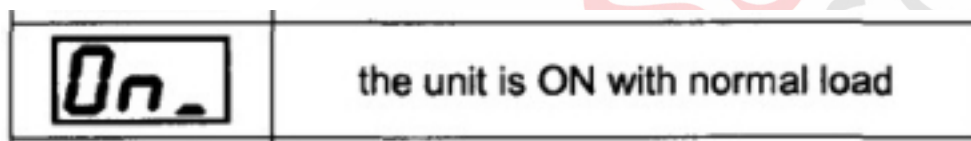

- As well as showing the dew point, the readout may indicate several fault codes as suggested below.

### Typical Fault Codes

The readout will indicate a variety of 'fault codes', the most common being as follows:

ESA

#### **Energy Saving Mode.**

- The Dew Point has been running at below -1°C for over 6 minutes.
- The Unit will automatically restart operation at 6°C.

PFI

#### **Temperature Probe Alarm.**

- The Temperature Probe is not working properly. It may not be connected to the Board, or the Probe may be defective.
- Replace the Probe if necessary.

HEA

#### **High Temperature Alarm.**

- The Dew Point has been running at above 12.5°C for over 6 minutes. The Unit must be manually turned off and on.
- The fault could be caused by a dirty radiator, high ambient temperature, a faulty Fan, or a faulty refrigerant Compressor, to name a few.

## Separator Filter and Refrigerated Air Dryer (cont'd)

### Typical Separator Filter

As previously noted, the Separator Filter is located between the Air End and the Refrigerated Dryer. It contains a 1 micron Separator Element which protects the Dryer Unit by removing liquids and solid particles 1 micron and larger.



### Filter Element Replacement

To replace a dirty Filter Element:

- Shut the Compressor Unit off.
- Bleed any compressed air from the system to ensure there is no pressure at the Filter.
- Unscrew the Bowl from the assembly and remove the filter element
- Clean any debris from the inside of the Bowl
- Remove the O-ring from the inside of the Canister Head
- Install the new O-ring making sure it is properly seated
- Place the new 1 micron Separator Filter Element into the Bowl (the filter is self-centring).
- Screw the Canister with the Element inside it to the Canister Head until the indicators line up.
- Gauge will return to **green** when Filter is once again under pressure.

## Troubleshooting Guide



**When servicing the Air Compressor, shut off all power to the Unit, and drain it of air pressure.**

The 'Conditions', 'Causes', and 'Suggested Corrections' as indicated below and on the following page(s) are only a guideline for troubleshooting that we have found to be most common.

Though this information is provided in this booklet, it is assumed and expected that any personnel involved in the servicing of an Air Compressor Unit is knowledgeable with this type of equipment. Do not attempt to service a Compressor Unit unless you are familiar with it, as there are many issues that may come into play, the most important being personal safety and the welfare of the Unit.

Should you have any questions, or require servicing to your Unit, please contact your local Champion Distributor/Service Center.

<b>Condition:</b>	<b>Cause:</b>	<b>Suggested Correction:</b>
A. Unit won't start.	No power to the Unit.  Loose and/or missing wires in the electrical circuit.  Motor Overload is tripped.  Compressor over-heated and stopped.  Unit shut off because pressure is not below 110 psi.  Automatic Idle Time stopped the Unit.  Power interruption.	Check that power at the disconnect or breaker is on. Also, check primary and secondary fuses inside the control box.  Check that all wiring connections are tight. With a wiring schematic, check that all wiring is present and correct.  Reset the overload inside the Control Panel.  Insufficient air flow to cool Unit. Ambient temperature too high. Heat Exchanger is dirty. Faulty Temperature Switch. Oil level is low.  Drop pressure below 110 psi.  Drop the pressure below 110 psi.  Reset the Unit.

**Trouble Shooting Guide (cont'd)**

<b><u>Condition:</u></b>	<b><u>Cause:</u></b>	<b><u>Suggested Correction:</u></b>
B. No or Insufficient Air Flow.	<p>Air Filter is dirty.</p> <p>Oil Separator is blocked.</p> <p>Intake Valve is faulty.</p> <p>Air leaks in the system.</p> <p>Pressure limits are incorrectly set.</p> <p>Blowdown Solenoid Valve is open.</p> <p>Belt is broken.</p>	<p>Replace the Air Filter.</p> <p>Replace the Oil Separator.</p> <p>Repair or replace the Intake Valve.</p> <p>Check the Unit and system for air leaks.</p> <p>Adjust the pressure settings.</p> <p>Check the wiring to the Solenoid and replace as necessary.</p> <p>Check Belt tension and that Belt is in good condition.</p>
C. Unit is overheating.	<p>Ambient temperature is too high.</p> <p>Blocked air circulation at the Unit.</p> <p>Heat Exchanger is dirty.</p> <p>Oil level is too low.</p> <p>Using wrong type of compressor oil.</p> <p>Thermo Valve is faulty.</p> <p>Oil Filter is blocked.</p> <p>Temperature Sensor is faulty.</p> <p>Cabinet door/panel is open/off.</p>	<p>Check cooling air circulation.</p> <p>Check the air circulation in and around the Unit.</p> <p>Clean the Heat Exchanger</p> <p>Add oil as required.</p> <p>Change to the factory recommended oil.</p> <p>Check and repair as necessary.</p> <p>Replace the Oil Filter.</p> <p>Check the wiring to the Temperature sensor. Replace the Sensor if necessary.</p> <p>Secure the door/panel to the Unit.</p>
D. Compressor Starts Slowly.	<p>Intake Valve Seal is closed.</p> <p>Ambient temperature is too low.</p> <p>Minimum Pressure Valve leaking back to Air End.</p> <p>Minimum Pressure Valve setting is too high.</p> <p>Using wrong type of oil.</p>	<p>Intake Valve is seized. Repair or replace.</p> <p>Stop and restart once ambient increases.</p> <p>Repair or replace the Minimum Pressure Valve.</p> <p>Adjust Minimum Pressure Valve setting to 65 psi.</p> <p>Change to factory recommended oil.</p>
E. Intake Valve Leaks Oil When Unit Stops.	<p>Intake Valve Seal leaks.</p> <p>Intake Valve stuck in open position.</p> <p>Blowdown Solenoid not functioning.</p>	<p>Repair using an Intake Valve Repair Kit.</p> <p>Repair or replace the Intake Valve.</p> <p>Replace the Solenoid.</p>

**Trouble Shooting Guide (cont'd)**

<b><u>Condition:</u></b>	<b><u>Cause:</u></b>	<b><u>Suggested Correction:</u></b>
F. Oil Consumption is Too High.	<p>Oil level is too high.</p> <p>Oil Return Line (Scavenge Line) is blocked.</p> <p>Oil Separator is saturated with oil.</p> <p>Wrong type of oil used.</p> <p>Unit load is light or excessive load/idle cycles.</p>	<p>Reduce the oil level to the proper level.</p> <p>Clean and/or replace the Scavenge Line Sight Glass.</p> <p>Replace the Oil Separator.</p> <p>Change to factory recommended oil.</p> <p>Ensure Unit is set to operate at correct pressures, and there is a <u>minimum</u> of 20 psi differential. Also the Unit could be oversized for the tank capacity.</p>
G. Compressor Surges.	<p>Restriction in Hoses.</p> <p>Pressure Switch setting is incorrect or malfunctioning.</p> <p>Blockage at Unit outlet.</p>	<p>Flush out or replace.</p> <p>Set pressure as per instructions or replace.</p> <p>Check for obstructions in outlet piping.</p>
H. High Power Consumption.	<p>Improper air pressure settings.</p> <p>Blowdown Solenoid is not functioning.</p> <p>The voltage in the building is too low or there is a phase imbalance.</p> <p>The Motor is failing.</p>	<p>Reset the pressure as per factory defaults.</p> <p>Inspect or replace as necessary.</p> <p>Contact an Electrician to verify.</p> <p>Have Motor inspected.</p>
I Fault Alarms.	<p>Red Light On Solid: Anti-Rotation</p> <p>Red Light Fast Flash: Power Interruption</p> <p>Red Light Two Flashes: Service Due</p> <p>Red Light Three Flashes: Overload Fault</p>	<p>See 'Page 26'.</p>



**Standard Warranty**  
**Oil-Lubricated Rotary Screw Packages**  
**D Series, DRS Series**

**STANDARD WARRANTY**

Champion (the “Company”) warrants to each original retail purchaser (“Purchaser”) of its new products from the Company or its authorized distributor that such products are, at the time of delivery to the Purchaser, free of defects in material and workmanship. **This Standard Warranty statement applies to compressors shipped after May 1<sup>st</sup>, 2015.**

**STANDARD WARRANTY PERIOD**

The Company’s obligation under this warranty is limited to repairing or, at its option, replacing, during normal business hours at an authorized service facility of the Company, any part which in its judgment proved not to be as warranted within the applicable warranty period as follows. **Regular maintenance in accordance with the service manual is required. Use of genuine Champion OEM parts and lubricants are highly recommended. If a component failure is deemed a result of using non-genuine Champion parts and lubricants, warranty will not be allowed.**

COMPONENT	STANDARD WARRANTY COVERAGE	DETAILS
Package	12 months from startup or 15 months from date of shipment to first purchaser, whichever occurs first	All components within the package, excluding normal wear items
Airend	12 months from startup or 15 months from date of shipment to first purchaser, whichever occurs first	Normal wearing items, such as shaft seals and inlet valve components, along with the servicing of these items is not covered under the warranty unless deemed as material or workmanship defects. Any disassembly or partial disassembly of the airend, or failure to return the “unopened” airend per Company instructions, will be cause for denial of warranty.
Electric Motors	12 months from startup or 15 months from date of shipment to first purchaser, whichever occurs first	Includes both drive motor and cooling fan motor. For nonstandard motors, the original manufacturer’s warranty will take precedence.
Major Package Components	12 months from startup or 15 months from date of shipment to first purchaser, whichever occurs first	Includes package controller, variable frequency drive if applicable, air/oil reservoir, air/oil cooler, and precision mixing valve (VS Series).
Labor	<p>Package / Electric Motors: 12 months from startup or 15 months from date of shipment to first purchaser, whichever occurs first</p> <p>Airend / Major Package Components: 12 months from startup or 15 months from date of shipment to first purchaser, whichever occurs first</p>	Service will be provided by Company representative or authorized service personnel, for repair or replacement of any product or part which in the Company’s sole judgment is proved not to be as warranted. Labor shall be limited to the amount specified in the Company’s labor rate schedule. All costs of transportation of product, parts, and repaired or replacement parts claimed not to be as warranted to and from such service facilities shall be borne by the Purchaser. The Company may require the return of any part claimed not to be as warranted to one of its facilities as designated by Company, transportation prepaid by Purchaser, to establish a claim under this warranty. Replacement parts provided under the terms of the warranty are warranted for the remainder of the Warranty Period.

**NO WARRANTY IS MADE WITH RESPECT TO:**

1. ANY PRODUCT WHICH HAS BEEN REPAIRED OR ALTERED IN SUCH A WAY, IN THE COMPANY’S SOLE JUDGMENT, AS TO AFFECT THE PRODUCT ADVERSELY
2. ANY PRODUCT WHICH HAS, IN THE COMPANY’S SOLE JUDGMENT BEEN SUBJECT TO NEGLIGENCE, ACCIDENT, IMPROPER STORAGE, OR IMPROPER INSTALLATION OR APPLICATION
3. ANY PRODUCT WHICH HAS NOT BEEN OPERATED OR MAINTAINED IN ACCORDANCE WITH THE RECOMMENDATIONS OF THE COMPANY
4. ANY RECONDITIONED OR PRIOR OWNED PRODUCT

**STANDARD WARRANTY DISCLAIMER**

THE FOREGOING WARRANTY IS EXCLUSIVE AND IT IS EXPRESSLY AGREED THAT, EXCEPT AS TO TITLE, THE COMPANY MAKES NO OTHER WARRANTIES AND HEREBY EXPRESSLY DISCLAIMS ALL OTHER WARRANTIES, INCLUDING WITHOUT LIMITATION, EXPRESSED, IMPLIED OR STATUTORY WARRANTIES, INCLUDING ANY IMPLIED WARRANTY OF MERCHANTABILITY OR FITNESS FOR A PARTICULAR USE. THE REMEDY PROVIDED UNDER THIS WARRANTY SHALL BE THE SOLE, EXCLUSIVE AND ONLY REMEDY AVAILABLE TO PURCHASER AND IN NO CASE SHALL THE COMPANY BE SUBJECT TO ANY OTHER OBLIGATIONS OR LIABILITIES. UNDER NO CIRCUMSTANCES SHALL THE COMPANY BE LIABLE FOR SPECIAL, INDIRECT, INCIDENTAL OR CONSEQUENTIAL DAMAGES, EXPENSES, LOSSES OR DELAYS HOWSOEVER CAUSED. NO STATEMENT, REPRESENTATION, AGREEMENT, OR UNDERSTANDING, ORAL OR WRITTEN, MADE BY ANY AGENT, DISTRIBUTOR, REPRESENTATIVE, OR EMPLOYEE OF THE COMPANY WHICH IS NOT CONTAINED IN THIS WARRANTY WILL BE BINDING UPON THE COMPANY UNLESS MADE IN WRITING AND EXECUTED BY AN OFFICER OF THE COMPANY. THIS WARRANTY SHALL NOT BE EFFECTIVE AS TO ANY CLAIM WHICH IS NOT PRESENTED WITHIN 30 DAYS AFTER THE DATE UPON WHICH THE PRODUCT IS CLAIMED NOT TO HAVE BEEN AS WARRANTED. ANY ACTION FOR BREACH OF THIS WARRANTY MUST BE COMMENCED WITHIN ONE YEAR AFTER THE DATE UPON WHICH THE CAUSE OF ACTION OCCURRED. ANY ADJUSTMENT MADE PURSUANT TO THIS WARRANTY SHALL NOT BE CONSTRUED AS AN ADMISSION BY THE COMPANY THAT ANY PRODUCT WAS NOT AS WARRANTED. WARRANTY IS NOT TRANSFERABLE

# Premium Warranty Plan

## Oil-Lubricated Rotary Screw Packages

### D Series, DRS Series

The extended warranty is available on all new Champion oil-lubricated rotary screw / rotary vane packages **shipped after May 1<sup>st</sup>, 2015**. To receive the extended aircend and package component warranty, the requirements listed below must be performed and documented during the full warranty period. In the event of a claim under this warranty, documentation shall be provided evidencing full compliance with this requirement.

#### PREMIUM WARRANTY PLAN PERIOD

Champion (the "Company") shall warrant the components identified below to be free of defects in material and workmanship for the warranty period. Normal wearing components and servicing of these items is not covered under the premium warranty. The Company's obligation under this warranty is limited to repairing or, at its option, replacing, during normal business hours at an authorized service facility of the Company, any part which in its sole judgment proved not to be as warranted within the applicable warranty period as follows. Regular maintenance in accordance with the service manual and use of genuine Champion OEM parts and lubricants is required.

COMPONENT	PLATINUM EXTENDED WARRANTY COVERAGE	DETAILS
Package	<b>12 months (1 year)</b> from startup or <b>15 months</b> from date of shipment to first purchaser, whichever occurs first	All components within the package, excluding normal wear items
Aircend	<b>60 months (5 years)</b> from date of initial startup or <b>63 months</b> from shipment, whichever occurs first	Normal wearing items, such as shaft seals and inlet valve components, along with the servicing of these items is not covered under the warranty unless deemed as material or workmanship defects. Any disassembly or partial disassembly of the aircend, or failure to return the "unopened" aircend per Company instructions, will be cause for denial of warranty
Electric Motors	<b>60 months (5 years)</b> from date of initial startup or <b>63 months</b> from shipment, whichever occurs first ( <i>Excludes 1ph motors</i> )	Includes both drive motor and cooling fan motor. For nonstandard motors, the original manufacturer's warranty will take precedence.
Major Package Components	<b>60 months (5 years)</b> from date of initial startup, or <b>63 months</b> from shipment, whichever occurs first	Includes package controller, variable frequency drive if applicable, air/oil reservoir, air/oil cooler.
Labor	<p><b>Package:</b> 12 months from startup or 15 months from date of shipment to first purchaser, whichever occurs first</p> <p><b>Aircend / Major Package Components:</b> 60 months from date of initial startup, or 63 months from shipment, whichever occurs first</p>	Service will be provided by Company representative or authorized service personnel, for repair or replacement of any product or part which in the Company's sole judgment is proved not to be as warranted. Labor shall be limited to the amount specified in the Company's labor rate schedule. All costs of transportation of product, parts, and repaired or replacement parts claimed not to be as warranted to and from such service facilities shall be borne by the Purchaser. The Company may require the return of any part claimed not to be as warranted to one of its facilities as designated by Company, transportation prepaid by Purchaser, to establish a claim under this warranty. Replacement parts provided under the terms of the warranty are warranted for the remainder of the Warranty Period.

#### PREMIUM WARRANTY PLAN REQUIREMENTS

1. The **Premium Warranty Registration Form** (BP-46) must be completed and returned to Champion within 30 days of the compressor package start-up date.
2. Use of **Genuine Champion OEM parts and lubricant (or warranty kits)** as specified in the service manual must be purchased from an authorized Champion distributor. **Maintenance shall be performed in accordance to the table found below along with the recommended maintenance schedule found in the service manual for the appropriate compressor package.** Consult the service manual for proper maintenance intervals for the operating hours of the equipment.

**D Series, DRS Series:**

Component	Change Interval
Oil Filter	Every 2000hrs or 6 months, whichever occurs first
Oil Sample	Every 2000hrs or 6 months, whichever occurs first
Lubricant	Change per recommendations of the Oil Analysis or hour Life rating of lubricant or as indicated by controller or 12 months, whichever occurs first
Separator	Every 4000hrs or 12months, whichever occurs first
Inlet Air Filter	Every 2000hrs or 6 months, whichever occurs first
Control Box Filter	Every 2000hrs or 6 months, whichever occurs first
Cabinet Air Filter	Every 2000hrs or 6 months, whichever occurs first

- Participation in Champion’s oil analysis sampling program is required. An oil sample must be sent to our lubricant analysis laboratory every **2000 hours or every 6 months**, whichever occurs first. Any recommendations detailed in the oil analysis report must be followed as outlined in the report. Oil sample bottles are to be obtained from your local authorized Gardner Denver distributor.
- The use of approved Champion lubricants is required. The following lubricants are approved for warranty and must be changed in accordance with the above maintenance tables or a **minimum of every 12 months**. Oil filter and separator elements must be replaced at the time of the lubricant change.

**D Series, DRS Series:**

**RotorLub 8000, RotorLub 8000TH, RotorLub 4000, Rotorlub 4000FG, RotorLub 4000FG-68**

- A log of all maintenance performed must be maintained with the corresponding operational hours. This includes the following changes: air filter, oil filter, separator, and lubricant. All other maintenance and repairs also require logging and documentation with corresponding hours.

**PREMIUM WARRANTY PLAN DISCLAIMER**

CHAMPION RESERVES THE RIGHT TO CHANGE THE PREMIUM WARRANTY PLAN AND/OR REQUIREMENTS AS DEEMED APPROPRIATE BY THE COMPANY. CHAMPION RESERVES THE RIGHT TO REFUSE PARTICIPATION IN THE PREMIUM WARRANTY PLAN TO ANY DISTRIBUTOR AND/OR END CUSTOMER OF THE COMPRESSOR. THIS PREMIUM WARRANTY PLAN IS SUPPLEMENTAL TO THE STANDARD WARRANTY. COMPANY MAKES NO OTHER WARRANTY OR REPRESENTATION OF ANY KIND, EITHER EXPRESS OR IMPLIED. THE FOREGOING WARRANTY IS EXCLUSIVE AND IT IS EXPRESSLY AGREED THAT, EXCEPT AS TO THE TITLE, COMPANY MAKES NO OTHER WARRANTIES EXPRESSED, IMPLIED, OR STATUTORY, INCLUDING ANY IMPLIED WARRANTY OF MERCHANTABILITY. THIS WARRANTY SHALL NOT BE EFFECTIVE AS TO ANY CLAIM WHICH IS NOT PRESENTED WITHIN 30 DAYS AFTER THE DATE UPON WHICH THE PRODUCT IS CLAIMED NOT TO HAVE BEEN AS WARRANTED. ANY ACTION FOR BREACH OF THIS WARRANTY MUST BE COMMENCED WITHIN ONE YEAR AFTER THE DATE UPON WHICH THE CAUSE OF ACTION OCCURRED.

**NO WARRANTY IS MADE WITH RESPECT TO:**

- ANY PRODUCT WHICH HAS BEEN REPAIRED OR ALTERED IN SUCH A WAY, IN THE COMPANY’S SOLE JUDGMENT, AS TO AFFECT THE PRODUCT ADVERSELY
- ANY PRODUCT WHICH HAS, IN THE COMPANY’S SOLE JUDGMENT BEEN SUBJECT TO NEGLIGENCE, ACCIDENT, IMPROPER STORAGE, OR IMPROPER INSTALLATION OR APPLICATION
- ANY PRODUCT WHICH HAS NOT BEEN OPERATED OR MAINTAINED IN ACCORDANCE WITH THE RECOMMENDATIONS OF THE COMPANY
- ANY RECONDITIONED OR PRIOR OWNED PRODUCT

MODEL NO.	PRODUCT NO.	HP	PRESSURE PSI	ACFM @ LOAD PRESSURE	MOTOR RPM	NOMINAL SOUND @ 1 METRE	FULL LOAD CURRENT (AMPS)	AIR RECEIVER GAL.	DRYER	FILTER ELEMENT	WEIGHT LBS
							230V/1/60				
D5	S-002520-CH	5	110-145	15	1740	65 dBA	28	60	ASD-15 115V, 60Hz, 2.2A	1 MICRON	505



**INSTALLATION REQUIREMENTS**

1. MAINTAIN 3 FEET DISTANCE FOR WALLS AND OTHER OBJECTS FOR PURPOSE OF COOLING AND SERVICING.
2. COMPRESSOR MUST BE LEVEL AND ANCHORED DOWN TO SOLID LEVEL FLOOR.
3. AMBIENT CONDITIONS:  
10°C (50°F) MIN. 40°C (104°F) MAX.

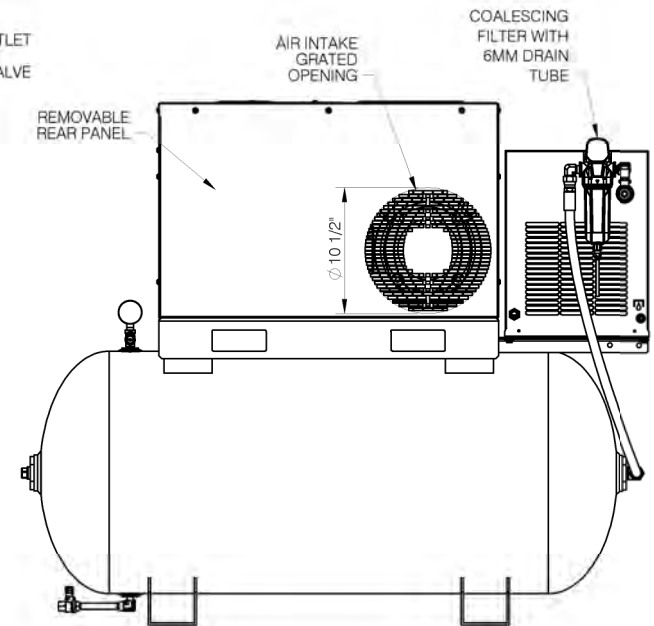
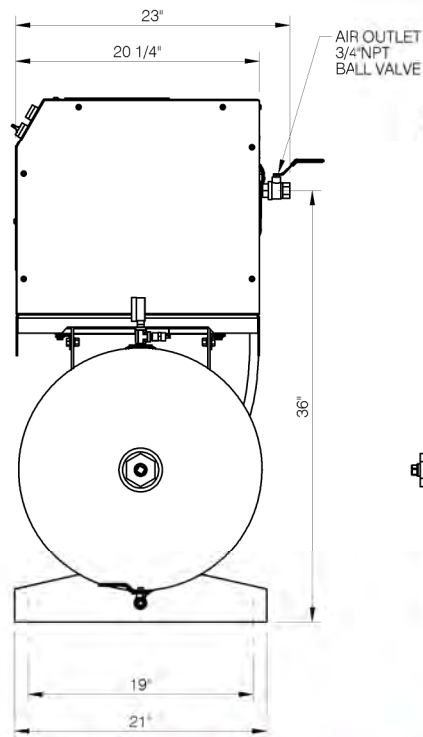
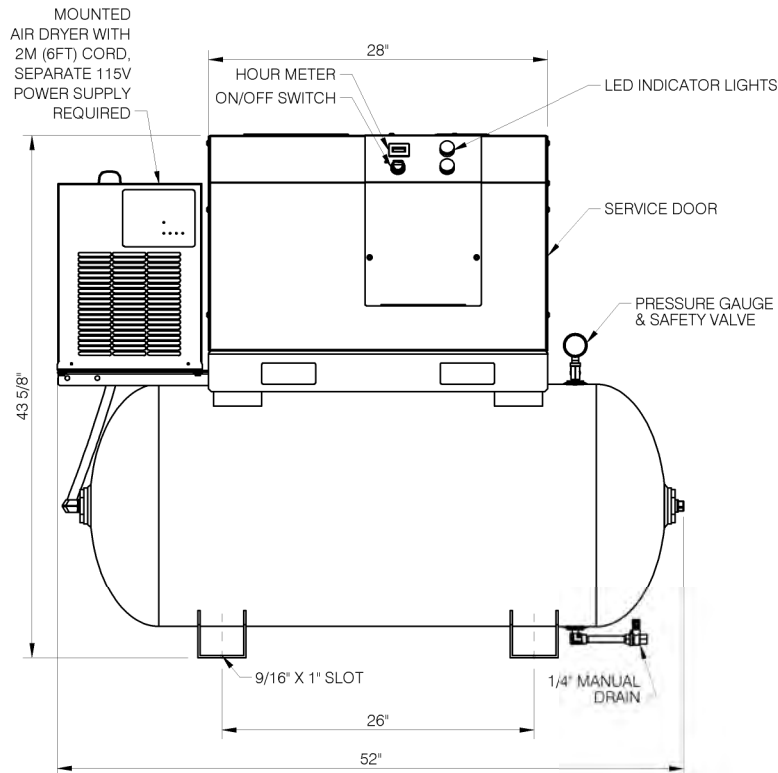
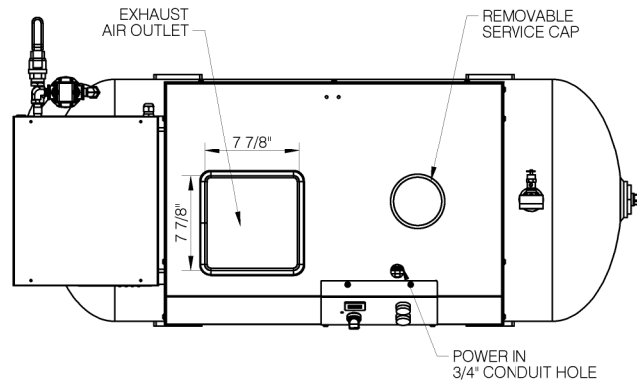

IMPORTANT NOTE: This print is the confidential property of GARDNER DENVER, INC. It is not to be used or reproduced in any manner, nor submitted to other parties for examination without the prior approval of GARDNER DENVER, INC. GARDNER DENVER, INC. is continually trying to improve its products, specifications subject to change without notice.

REV.	DATE	REVISION DESCRIPTION	ECN NO.

<b>CHAMPION</b>				NAME OF PROJECT		DESCRIPTION OF DRAWING	
				D5 SCREW COMPRESSOR		SALES-ENGINEERING DRAWING	
DRAWN BY	CHECKED BY	DATE	SCALE	DRAWING NO.	SHT NO	REV.	
EH		03/06/19	N.T.S	D5-SE	1/1	00	

MAINTENANCE KIT		
M1	DSC-002835	SHAFT SEAL KIT
M2	DSC-002878	BELT TENSION IDLER KIT
M3	DSC-002879	BELT TENSIOIN ROD KIT

NO.	PART NUMBER	DESCRIPTION	QTY.
1	DSC-002813	AIR END - 230V COIL	1
2	SS-657	3/8-16 HEX NUT	4
3	SS-1502	3/8" LOCKWASHER	8
4	DSC-002784	AIR END BRACKET	2
5	SS-1503	5/16" LOCKWASHER	6
6	DSC-678	M8 X 16MM HHCS	6
7	SS-23	3/8-16 X 3/4 HHCS B/M	4

NO.	PART NUMBER	DESCRIPTION	QTY.
8	DSC-002791	FINGER GUARD	1
9	MO-9025	MOTOR 5HP 230/60/1	1
10	DSC-001330	VIBRATION ISOLATOR	4
11	DSC-002790	SUB-BASE ASSEMBLY	1
12	PU-9278	AIR END PULLEY	1
13	DSC-002818	AIR END BUSHING	1
14	PU-9279	MOTOR PULLEY	1
15	DSC-001558	MOTOR BUSHING	1
16	DSC-002820	BELT	1
17	DSC-002814	FAN ASSEMBLY	1
18	SS-1506	1/2" MEDIUM LOCKWASHER	1
19	SS-01941	1/2-13 X 3/4 SHCS	1
20	DSC-002840	BELT TENSION ROD ASSEMBLY	1
21	DSC-002822	BELT TENSION GUIDE	1
22	DSC-002829	TENSION ARM ASSEMBLY	1
23	SS-10196	M8 SHOULDER SCREW 10X16MM	1
24	SS-1537	M12 FLAT WASHER	2
25	DSC-002839	ROLLER BEARING ASSEMBLY	1
26	SS-10133	M12 X 45MM HHCS	1
27	DSC-002823	SPRING	1
28	DSC-002824	HAND WHEEL	1
29	MH-9075	MOTOR HARNESS, 230/1	1

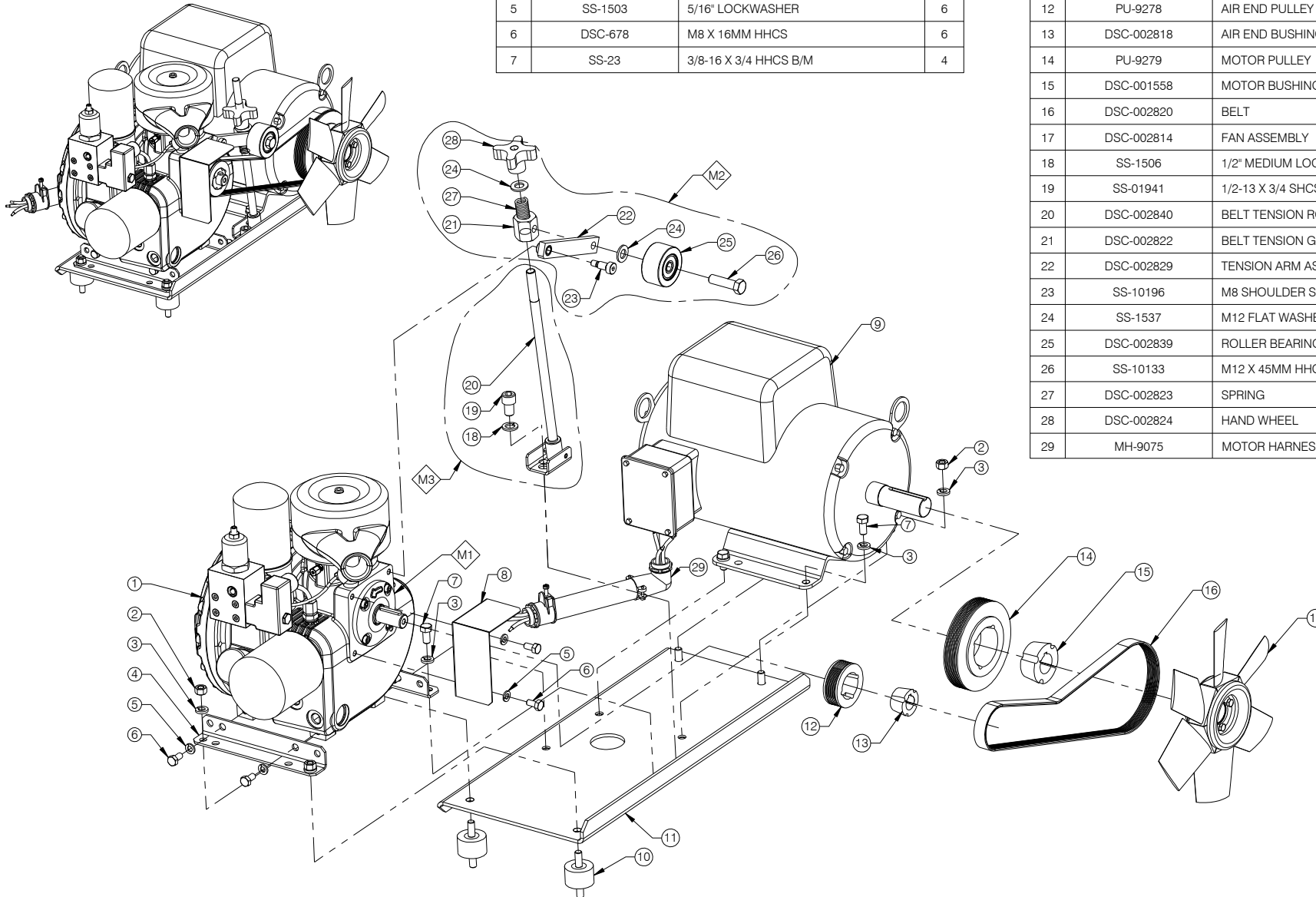

IMPORTANT NOTE: This print is the confidential property of GARDNER DENVER, INC. It is not to be used or reproduced in any manner, nor submitted to other parties for examination without the prior approval of GARDNER DENVER, INC. GARDNER DENVER, INC. is continually trying to improve its products, specifications subject to change without notice.

REV.	DATE	REVISION DESCRIPTION	PCN NO.

**CHAMPION**

NAME OF PROJECT				DESCRIPTION OF DRAWING		
D5 SCREW COMPRESSOR				DRIVE COMPONENTS		
DRAWN BY		CHECKED BY	DATE	SCALE	DRAWING NO.	SHT NO/REV.
DM	LT	01/31/19	N.T.S	D5-DRV	1/1	00

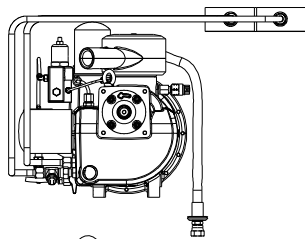
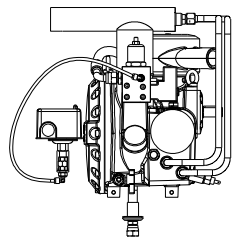

MAINTENANCE KITS		
NO	PART NUMBER	DESCRIPTION
M1	DSC-002057	THERMO VALVE REPAIR KIT
M2	DSC-001712	INTAKE VALVE REPAIR KIT
M3	DSC-001713	MINIMUM PRESSURE VALVE REPAIR KIT
---	MK-D5-CH	4000 HR / 1 YR MAINTENANCE KIT

NO.	PART NUMBER	DESCRIPTION	QTY.
1	DSC-002813	AIR END - 230V COIL	1
2	DSC-002219	COPPER WASHER 1/2"BSPP	1
3	DSC-002220	ADAPTER-SH 1/2"BSPP - JIC 8	1
4	DSC-427	BONDED WASHER 3/8"	5
5	DSC-001563	ADAPTER 3/8"BSPPM - JIC8	4
6	DSC-002825	ADAPTER 3/8"BSPP(M) - 3/8"NPT(M)	1
7	DSC-002828	BALL VALVE 3/8" NPTF X 3/8" NPTF	1
8	DD-00091	3/8"NPT X 1/2"DIA PNEU. FITTING	1
9	R8504	PE TUBING 1/2" OD	1.5'
10	DSC-001968	COPPER SEALING RING 1/4"BSPP	1
11	DSC-001564	ADAPTER 1/4"BSPPM - 1/4"NPTF	1
12	TIA-5165	SAFETY VALVE 165PSI	1
13	DSC-263	1/8" BONDED WASHER	1
14	DSC-001659	ADAPTER 1/8"BSPPM - 1/4"NPTF	1
15	DSC-102	ANTI-ROTATION PRESSURE SWITCH	1
16	DSC-002833	RUN TEE JIC-8(M) X JIC-8(F) X JIC-8(M)	1
17	DSC-002834	ADAPTER A5 TEMP PROBE	1
18	DSC-001217	BONDED WASHER 1/4" BSPP	1
19	DSC-002801	TEMPERATURE SWITCH, 1/4 BSPP, NC, 240VAC	1
20	DSC-002803	1/2 STEEL TUBE OIL FROM COOLER	1
21	DSC-002802	1/2 STEEL TUBE OIL TO COOLER	1
22	DSC-002815	HEAT EXCHANGER	1
23	DSC-185	PNEUMATIC ELBOW 1/8"BSPP X 6MM	1
24	DSC-444	1/4"NPT ELBOW X 6MM TUBE FITTING	1
25	DSC-482	PNEUMATIC TUBE, 6MM OD, BLACK	1
26	DSC-268	COUPLING 1/4"NPT FEMALE	1
27	SS-01777	1/4 X 1/1/2 GALV NIPPLE	1
28	DSC-002792-1	A5 PRESSURE SWITCH BRACKET	1
29	SSS-9003-115150	PRESSURE SWITCH 115-150PSI	1
30	SS-01872	7/8" DIA HOLE PLUG	1
31	DSC-001561	HOSE 26" STR-90	1
32	DSC-002836	1-1/2" DIA X 3/32" TH DIAPHRAM GROMMET	1
33	DSC-603-CH	OIL FILTER	1
34	DSC-002832-CH	AIR/OIL SEP. FILTER	1
35	DSC-001569	AIR FILTER	1
36	DSC-002957	SOLENOID ASSY W/ CABLE	1
37	DSC-001572	INTAKE VALVE	1
38	DSC-002969	AIR FILTER ASSEMBLY	1
39	DSC-002453	MINIMUM PRESSURE VALVE & HOUSING ASSEMBLY	1

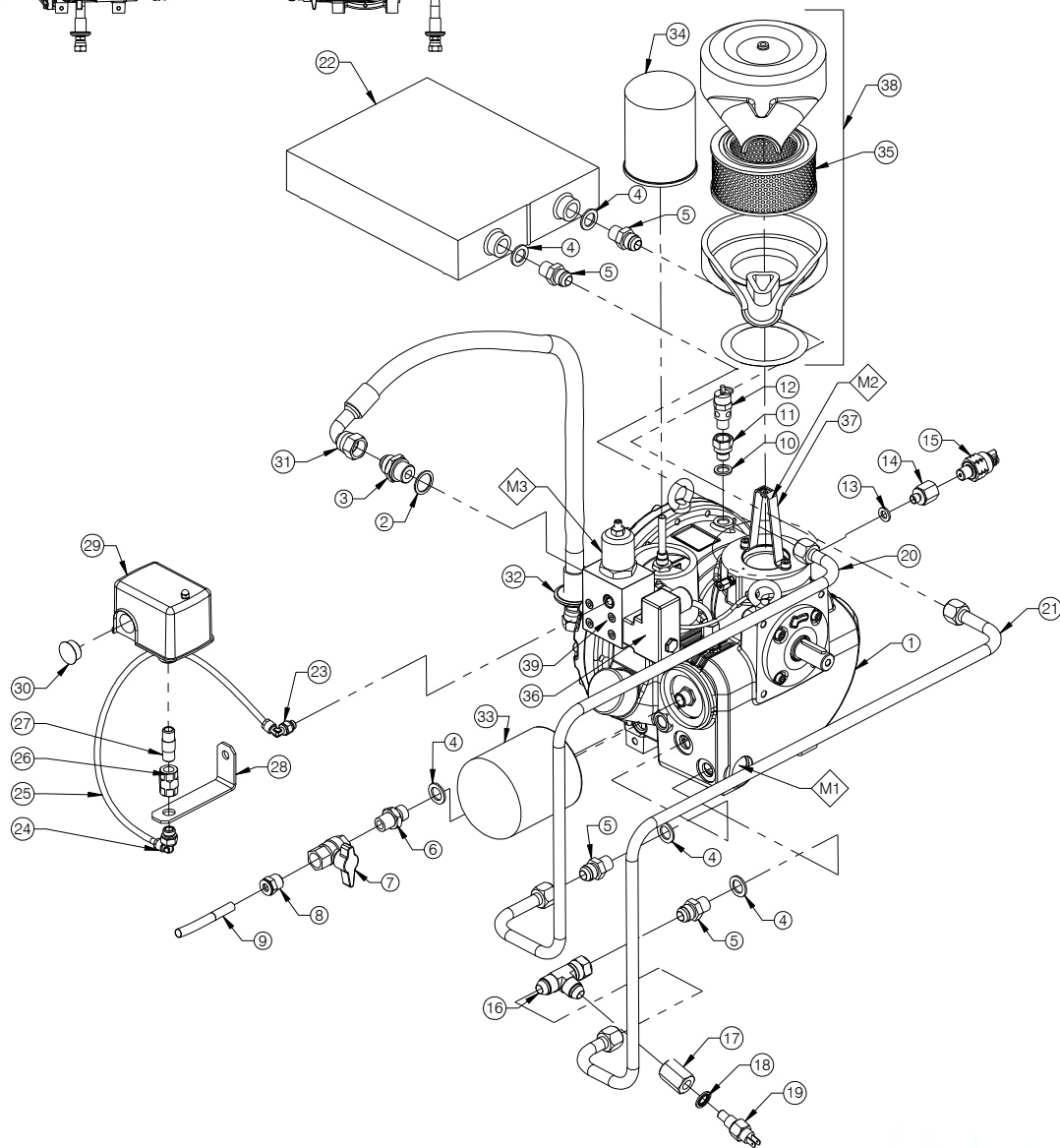

IMPORTANT NOTE: This print is the confidential property of GARDNER DENVER, INC. It is not to be used or reproduced in any manner, nor submitted to other parties for examination without the prior approval of GARDNER DENVER, INC. GARDNER DENVER, INC. is continually trying to improve its products, specifications subject to change without notice.

REV.	DATE	REVISION DESCRIPTION	PCN NO.



NAME OF PROJECT				DESCRIPTION OF DRAWING		
D5 SCREW COMPRESSOR				SYSTEM COMPONENTS		
DRAWN BY		CHECKED BY	DATE	SCALE	DRAWING NO.	SHT NO/REV.
DM		LT	02/01/19	N.T.S	D5-SYS	1/1 00

REV.	DATE	REVISION DESCRIPTION	PCN NO.

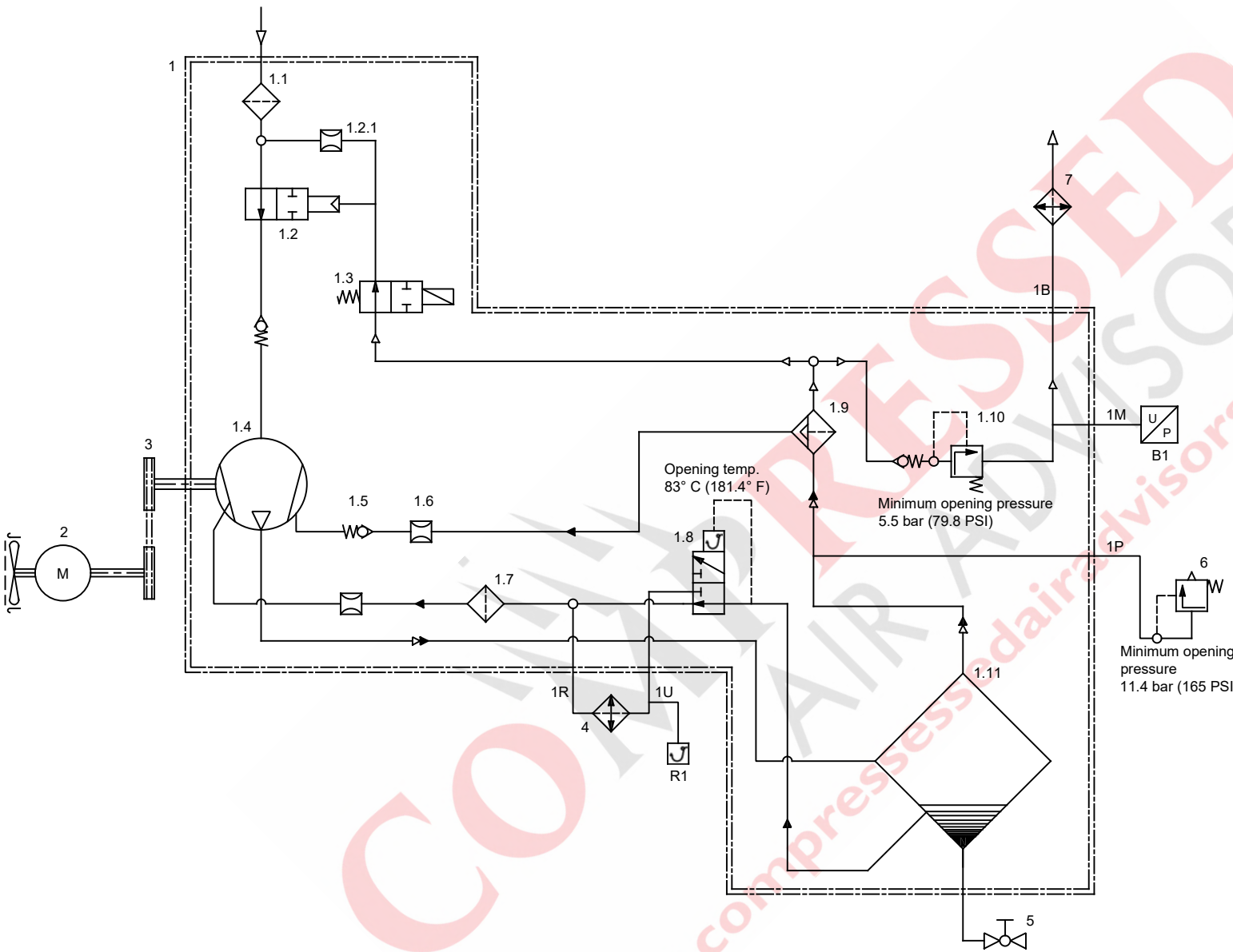

- 1. Encapsulated air end
  - 1.1 Air inlet filter
  - 1.2 Intake valve
  - 1.2.1 Venting orifice
  - 1.3 Solenoid valve - NO
  - 1.4 Air end
  - 1.5 Scavenge check valve
  - 1.6 Scavenge orifice
  - 1.7 Oil Filter
  - 1.8 Thermostatic valve
  - 1.9 Air/Oil separator
  - 1.10 Minimum pressure valve
  - 1.11 Air/Oil receiver
  - 1B. Outlet minimum pressure valve
  - 1M. Air connection (After minimum pressure valve)
  - 1P. Safety valve connection
  - 1R. Return from the oil cooler
  - 1U. Outlet thermostatic valve (Inlet to the oil cooler)
  - 2. Main motor
  - 3. Belt drive
  - 4. Oil cooler
  - 5. Oil drain valve
  - 6. Pressure relief valve
  - 7. Air cooler
- R1 Oil temperature  
B1 Sensor mains pressure

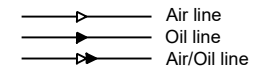

IMPORTANT NOTE: This print is the confidential property of GARDNER DENVER, INC. It is not to be used or reproduced in any manner, nor submitted to other parties for examination without the prior approval of GARDNER DENVER, INC. GARDNER DENVER, INC. is continuously trying to improve its products, specifications subject to change without notice.

FRACTIONAL DIMENSIONS:  $\pm 1/32$   
 DECIMAL DIMENSION:  $\pm .005$   
 ANGLES:  $\pm 1'$   
 \*UNLESS OTHERWISE SPECIFIED



NAME OF PROJECT				DESCRIPTION OF DRAWING		
D5 SCREW COMPRESSOR				P & ID DIAGRAM		
DRAWN BY		CHECKED BY		DATE	SCALE	DRAWING NO.
DM	EH	02/04/19	N.T.S.	D5-PID	1/1	00

REV.	DATE	REVISION DESCRIPTION	PCN NO.

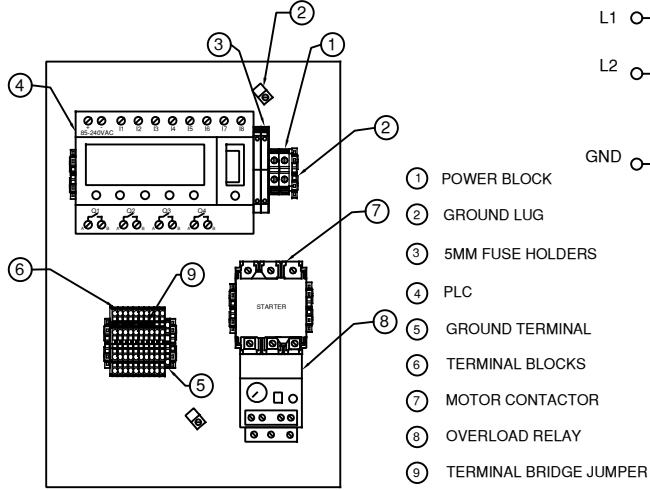

VOLTAGE	FUSE SIZE (A)		OVERLOAD SETTING
	F1	F2	
230	1.0	1.0	23

ID	PART NUMBER	DESCRIPTION
AR	DSC-102	Anti-Rotation Switch
AS	---	Add a jumper to enable automatic restart
CON	DSC-002808	Starter Contactor 32A, 240V
F1/F2	SS-9877	1.0 A, 5 mm fuse
FL	DSC-002805	Pilot light, red, 230Vac (DSC-002852 kit)
G	DSC-002804	Pilot light, green, 230Vac
HM	DSC-002806	Hour meter, panel mounted, 300Vac
I	DSC-002799	Selector switch, operator
OL	DSC-001284	Overload relay 16-24A
PLC	DSC-002800	PLC, D18, 4RO, 240Vac
PL	DSC-002804	Green pilot light, 230Vac (DSC-002852 kit)
PS	SSS-9003-115150	Pressure switch (110-145 psi)
R	DSC-002805	Pilot light, red, 230Vac
RC	ALTO1	RC suppressor, 250Vac
RSS1/2	DSC-002845	Remote start / stop switch, 2 pos., maintained
S	DSC-002846	NO contact for DSC-002845 (DSC-002852 kit)
S	DSC-002957	Solenoid with cable
SV	DSC-002838	16mm push button switch, 250Vac
TS	DSC-002801	Temperature switch, 240Vac
VR	DSC-002807	250V varistor for solenoid

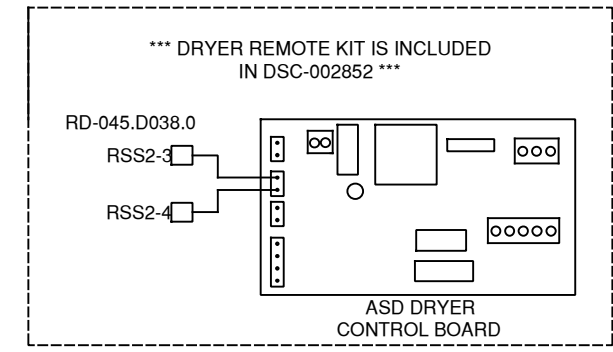
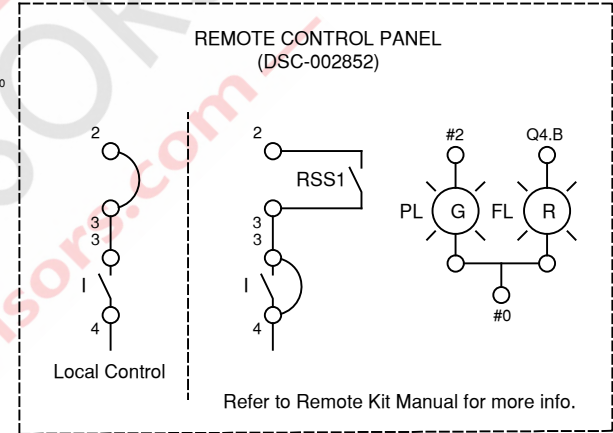
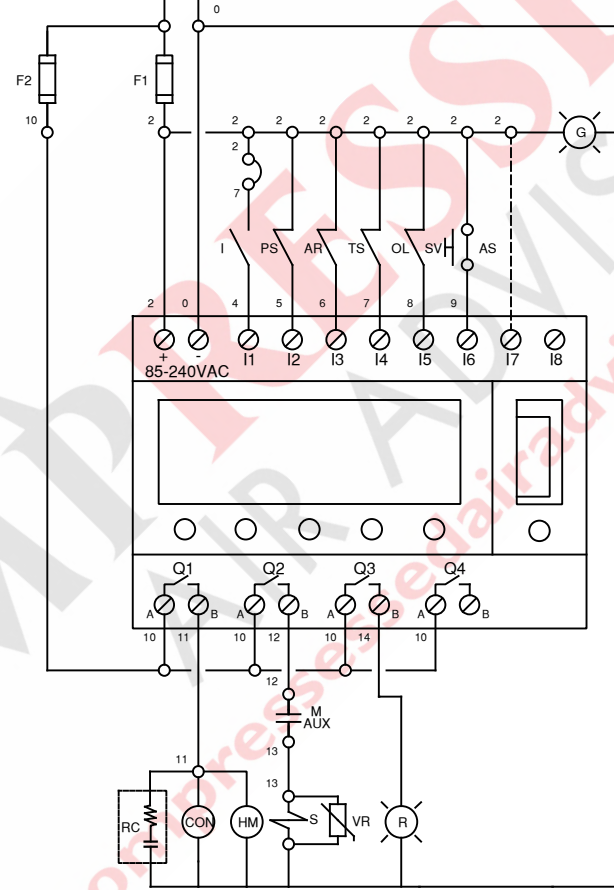

IMPORTANT NOTE: This print is the confidential property of GARDNER DENVER, INC. It is not to be used or reproduced in any manner, nor submitted to other parties. GARDNER DENVER, INC. is continuously trying to improve its products, specifications subject to change without notice.

FRACTIONAL DIMENSIONS: ±1/32  
 DECIMAL DIMENSION: ±.005  
 ANGLES: ±1°  
 \*UNLESS OTHERWISE SPECIFIED



NAME OF PROJECT				DESCRIPTION OF DRAWING		
D5 SCREW COMPRESSOR				ELECTRICAL SCHEMATICS WITH MICROPROCESSOR		
DRAWN BY		CHECKED BY	DATE	SCALE		DRAWING NO.
EH			02/01/19	N.T.S.		CSC15D5
					SHT NO	REV
					1/1	00