

MODEL NO.	PRODUCT NO.	HP	PRESSURE PSI	ACFM @ LOAD PRESSURE	MOTOR RPM	NOMINAL SOUND @ 1 METRE	FULL LOAD CURRENT (AMPS)	AIR RECEIVER GAL.	DRYER	FILTER ELEMENT	WEIGHT LBS
							230V/1/60				
D5	S-002520-CH	5	110-145	15	1740	65 dBA	28	60	ASD-15 115V, 60HZ, 2.2A	1 MICRON	505

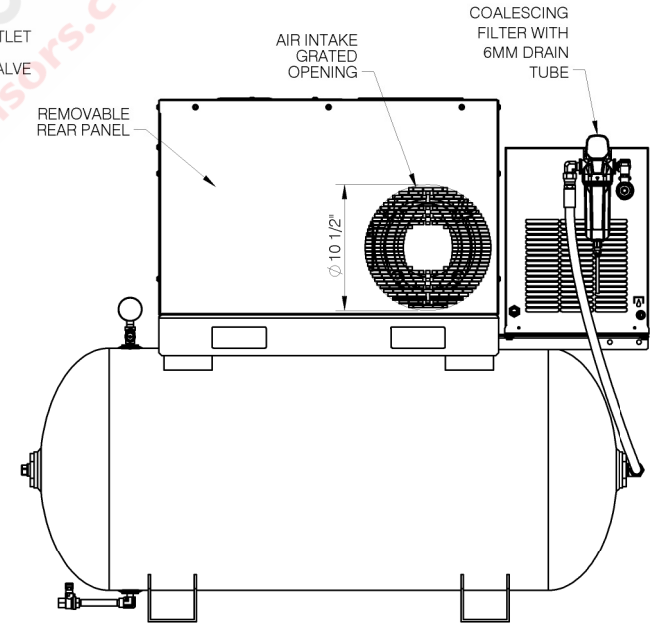

INSTALLATION REQUIREMENTS

1. MAINTAIN 3 FEET DISTANCE FROM WALLS AND OTHER OBJECTS FOR PURPOSE OF COOLING AND SERVICING.
2. COMPRESSOR MUST BE LEVEL AND ANCHORED DOWN TO SOLID LEVEL FLOOR.
3. AMBIENT CONDITIONS:
10°C (50°F) MIN. 40°C (104°F) MAX.

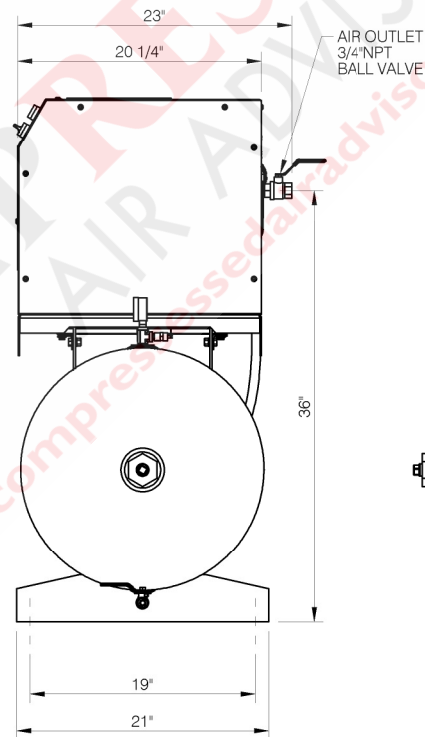
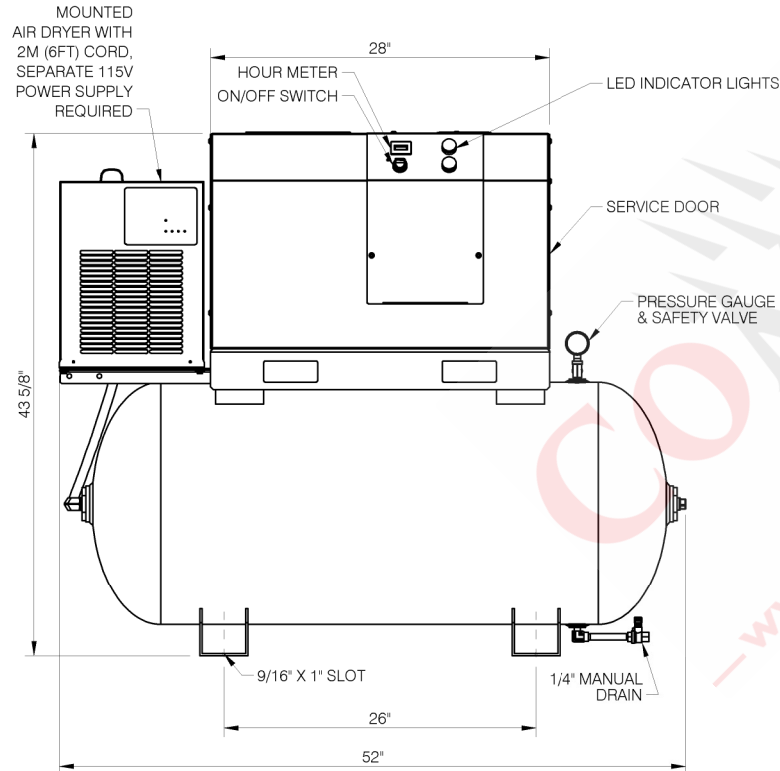
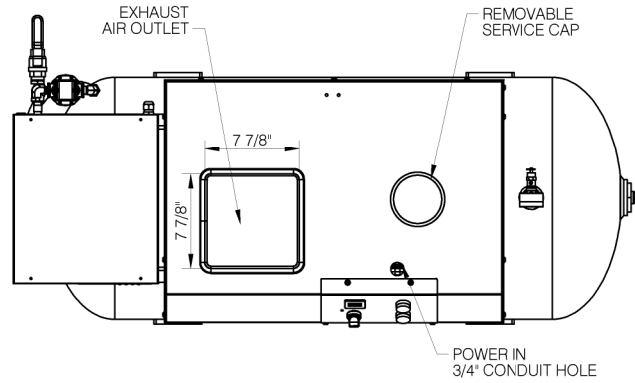

IMPORTANT NOTE: This print is the confidential property of GARDNER DENVER, INC. It is not to be used or reproduced in any manner, nor submitted to other parties for examination without the prior approval of GARDNER DENVER, INC. GARDNER DENVER, INC. is continually trying to improve its products, specifications subject to change without notice.

REV.	DATE	REVISION DESCRIPTION	ECN NO.

CHAMPION

NAME OF PROJECT				DESCRIPTION OF DRAWING	
D5 SCREW COMPRESSOR				SALES-ENGINEERING DRAWING	
DRAWN BY	CHECKED BY	DATE	SCALE	DRAWING NO.	SHT NO REV.
EH		03/06/19	N.T.S	D5-SE	1/1 00