

Code	
2200780021	03
Edition 05/2012	

INSTRUCTION AND MAINTENANCE MANUAL

SILENCED SCREW ROTARY COMPRESSOR UNITS

HP 3 - 5 - 7,5 - 10
KW 2,2 - 3,7 - 5,5 - 7,5

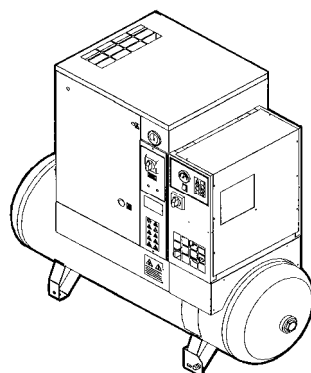

THIS MACHINE MUST BE CONNECTED TO TWO DIFFERENT POWER SUPPLIES: THREE-PHASE OR SINGLE-PHASE SUPPLY FOR THE COMPRESSOR SINGLE-PHASE SUPPLY FOR THE DRYER

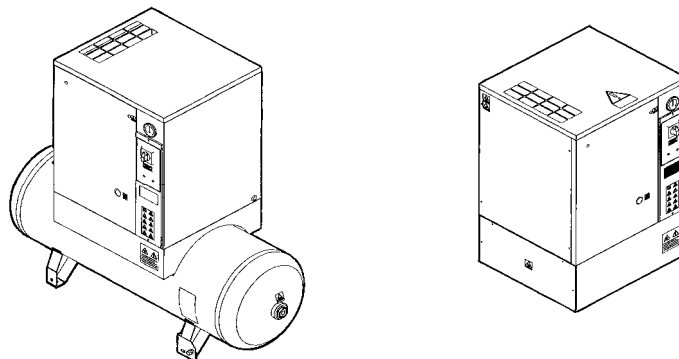

READ THIS MANUAL CAREFULLY BEFORE CARRYING OUT ANY OPERATIONS ON THE COMPRESSOR UNIT.



THIS MACHINE IS EQUIPPED FOR BOTH CONTINUOUS AND INTERMITTENT WORKING, HOWEVER TO AVOID CONDENSATION PROBLEMS IN THE OIL, THE MACHINE MUST OPERATE FILLED WITH AT LEAST 10% OF ITS TOTAL CAPACITY, CHECK FOR SIGNS OF CONDENSATION IN THE OIL BY FOLLOWING THE INSTRUCTIONS GIVEN IN CHAPTER 15.2

CONTENTS

PART A: INFORMATION FOR THE USER

- 1.0 GENERAL CHARACTERISTICS
- 2.0 INTENDED USE
- 3.0 OPERATION
- 4.0 GENERAL SAFETY STANDARDS
- 5.0 DESCRIPTION OF DANGER SIGNALS
- 6.0 DANGER ZONES
- 7.0 SAFETY DEVICES
- 8.0 POSITION OF PLATES
- 9.0 COMPRESSOR ROOM
- 10.0 TRANSPORT AND HANDLING
- 11.0 UNPACKING
- 12.0 INSTALLATION
- 13.0 DIMENSIONS AND TECHNICAL DATA
- 14.0 MACHINE ILLUSTRATION
- 15.0 ORDINARY MAINTENANCE TO BE DONE BY THE USER
- 16.0 PERIODS OF INACTIVITY
- 17.0 SCRAPPING THE UNIT
- 18.0 LIST OF SPARE PARTS FOR ROUTINE MAINTENANCE
- 19.0 TROUBLE-SHOOTING AND EMERGENCY REMEDIES

PART B: INFORMATION RESERVED FOR TECHNICALLY SKILLED PERSONNEL

- 20.0 STARTING UP
- 21.0 GENERAL ORDINARY MAINTENANCE REQUIRES TRAINED PERSONNEL
- 22.0 CHANGING THE OIL
- 23.0 CHANGING THE OIL SEPARATING FILTER
- 24.0 BELT TENSION
- 25.0 REPLACING THE BELT
- 26.0 FLOW DIAGRAM
- 27.0 CALIBRATIONS FOR DRYER

IMPORTANT: A COPY OF THE WIRING DIAGRAMS CAN BE FOUND INSIDE THE ELECTRIC BOARD OF THE COMPRESSOR.

SILENCED SCREW ROTARY COMPRESSOR UNITS

**HP 3 - 5 - 7,5 - 10
KW 2,2 - 3,7 - 5,5 - 7,5**

MACHINE AND MANUFACTURER IDENTIFICATION DATA

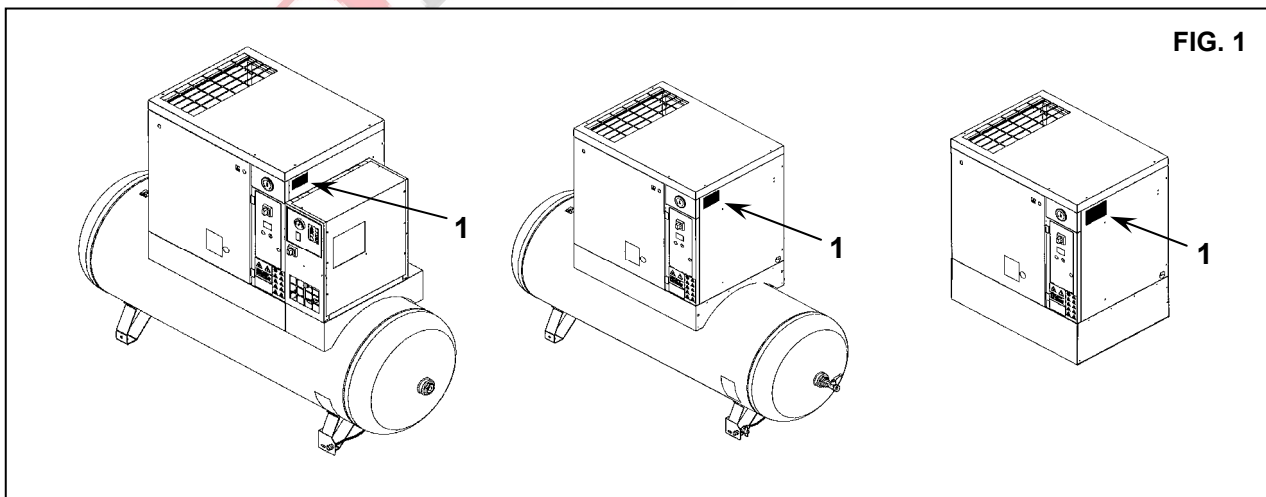

Position of the identification plate Fig. 1

ADDRESSES OF ASSISTANCE CENTRES

In the event of breakdown or malfunction of the machine, switch it off and do not tamper with it.

If repairs are needed, apply only to a technical assistance centre approved by the manufacturer and insist on the use of original spare parts.

Failure to comply with the above may endanger the safety of the machine.

INTRODUCTION

Keep this manual with care for future consultation; the use and maintenance manual is an integral part of the machine. Read this manual carefully before carrying out any operations on the compressor unit.

The installation of the compressor unit and all operations involving it must be performed in conformity with the regulations in force concerning electric plants and personal safety.

CHARACTERISTICS AND SAFETY PRECAUTIONS



MACHINE WITH AUTOMATIC START



BEFORE REMOVING THE PROTECTIVE GUARDS TO CARRY OUT ANY MAINTENANCE ON THE MACHINE, SWITCH OFF THE ELECTRIC POWER SUPPLY AND DISCHARGE THE RESIDUAL PRESSURE INSIDE THE UNIT.

ALL WORK ON THE ELECTRIC PLANT, HOWEVER SLIGHT, MUST BE CARRIED OUT BY PROFESSIONALLY SKILLED PERSONNEL.

THIS MACHINE IS NOT SUITABLE FOR EXTERNAL INSTALLATION

THIS MACHINE CORRESPOND TO THE ESSENTIAL SAFETY REQUIREMENTS FORESEEN FROM THE EUROPEAN STANDARD (2006/42 CE).

THE LUBRICATING LIQUIDS AND OTHER EVENTUAL FLUIDS MUST NOT BE DISCHARGED IN THE ENVIRONMENT. THESE POLLUTING AND HAZARDOUS PRODUCTS MUST COMPULSORY BE DISPOSED BY CHARGING AUTHORISED AND SPECIALISED FIRMS ACCORDING TO THE DIFFERENT TYPOLOGY OF PRODUCT.

DIFFERENTIATE THE COMPRESSOR COMPONENTS ACCORDING TO THE DIFFERENT CONSTRUCTION MATERIALS (PLASTIC, COPPER, IRON, OIL FILTER, AIR FILTER ECC...)

The manufacturer does not accept responsibility for damage caused as a result of negligence or failure to abide by the instructions given above.

AIR RECEIVER AND SAFETY VALVE:

- To limit internal corrosion, which could compromise the safety of the compressed air tank, **the condensation that is produced must be discharged at least once a day**. If an automatic drain fitted to the air receiver is present, it is necessary to check that it is working correctly every week and repair it if necessary.
- **The thickness of the receiver must be checked every year and also in accordance with legislation in force in the country where the receiver is installed.**
- **The tank cannot be used and must be replaced if the thickness falls below the minimum level given in the instruction documents for the tank.**
- The tank can be used within the temperature limits given in the conformity declaration.
- **The safety valves of the air receiver and oil receiver must be checked every year and replaced in accordance with legislation in force.**

NOT RESPECTING THE ABOVE MENTIONED PRESCRIPTION CAN RESULT IN AIR RECEIVER BURSTING HAZARD.

The manufacturer does not accept responsibility for damage caused as a result of negligence or failure to abide by the instructions given above.

1.0 GENERAL CHARACTERISTICS

The compressor units use single-stage screw rotary air compressors with oil injection.

The system is self-bearing and does not require bolts or other devices to anchor it to the floor.

The unit is completely assembled in the factory; the necessary connections for setting it up are:

- connection to the power mains (see installation chapter)
- connection to the compressed air network (see installation chapter)

2.0 INTENDED USE

The compressor has been built to supply compressed air for industrial use.

The machine cannot be used in premises where there is a risk of fire or explosion or where work is carried out which releases substances into the environment which are dangerous with regard to safety (for example: solvents, inflammable vapours, alcohol, etc.).

In particular the appliance cannot be used to produce air to be breathed by humans or used on direct contact with foodstuffs. These uses are allowed if the compressed air produced is filtered by means of a suitable filtering system (Consult the manufacturer for these special uses.)

This appliance must be used only for the purpose for which it was specifically designed.

All other uses are to be considered incorrect and therefore unreasonable.

The Manufacturer cannot be held responsible for any damage resulting from improper, incorrect or unreasonable use.

3.0 OPERATION

3.1 OPERATION FOR COMPRESSOR

The electric motor and the compressor unit are coupled by means of a belt transmission.

The compressor unit takes in the outside air through the suction valve. The intake air is filtered by the filter cartridge fitted upstream from the intake valve. Inside the compressor unit, the air and the lubricating oil are compressed and sent to the oil separating tank where the oil is separated from the compressed air; the air is then filtered again by the oil separating cartridge to reduce the amount of suspended oil particles to a minimum. The machine is fitted with a suitable air-cooling system.

The machine is protected by a special safety thermostat: if the oil temperature reaches $105 \pm 110 \text{ }^\circ\text{C}$ ($221 \pm 230 \text{ }^\circ\text{F}$) the machine cuts out automatically.

3.2 OPERATION FOR DRYER

At the moment of use the air flows from the tank to the drier and is then dried and sent to the distribution network. Dryer operation is described below. The gaseous refrigerant coming from the evaporator (4) is sucked by the refrigeration compressor (1) and it is pumped into the condenser (2). This one allows its condensation, eventually with the help of the fan (3); the condensed refrigerant passes through the dewatering filter (8) and it expands through the capillary tube (7) and goes back to the evaporator where it produces the refrigerating effect.

Due to the heat exchange with the compressed air which passes through the evaporator against the stream, the refrigerant evaporates and goes back to the compressor for a new cycle.

The circuit is equipped with a bypass system for the refrigerant; this intervenes to adjust the available refrigerating capacity to the actual cooling load.

This is achieved by injecting hot gas under the control of the valve (9): this valve keeps constant the pressure of the refrigerant in the evaporator and therefore also the dew point never decreases below $0 \text{ }^\circ\text{C}$ ($32 \text{ }^\circ\text{F}$) in order to prevent the condensate from freezing inside the evaporator.

The drier runs completely automatically; it is calibrated in the factory for a dew point of $\sim 3 \text{ }^\circ\text{C}$ ($37,4 \text{ }^\circ\text{F}$) and therefore no further calibrations are required.

DRYER FLOW DIAGRAM

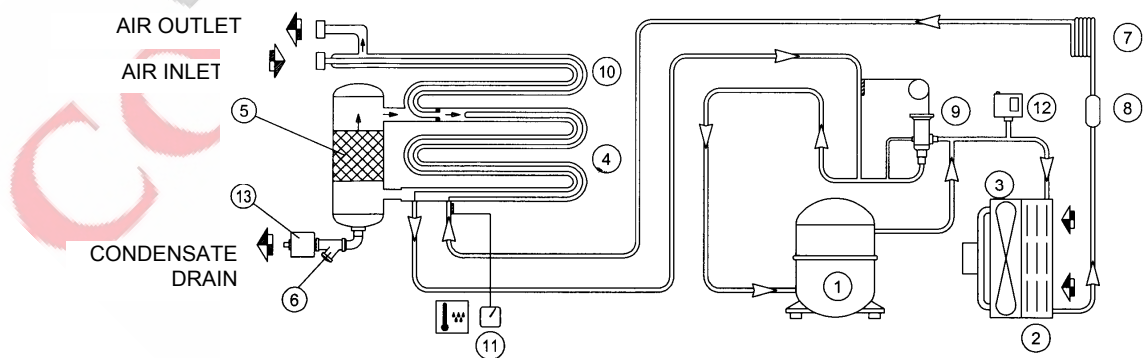

4.0 GENERAL SAFETY STANDARDS

The appliance may be used only by specially trained and authorized personnel.

Any tampering with the machine or alterations not approved beforehand by the Manufacturer relieve the latter of responsibility for any damage resulting from the above actions.











The removal of or tampering with the safety devices constitutes a violation of the European Standards on safety.

ATTENTION: UPSTREAM OF THE MACHINE INSTALL AN ISOLATOR KNIFE-SWITCH WITH AN AUTOMATIC CUTOFF AGAINST CURRENT SURGES AND EQUIPPED WITH A DIFFERENTIAL DEVICE FOR CALIBRATIONS SEE WIRING DIAGRAM



ALL WORK ON THE ELECTRIC PLANT, HOWEVE SLIGHT, MUST BE CARRIED OUT BY PROFESSIONALLY SKILLED PERSONEL.

5.0 DESCRIPTION OF DANGER SIGNALS

	1) FLUID EJECTION		6) HIGH PRESSURE
	2) DANGEROUS ELECTRIC VOLTAGE		7) HOT PARTS
	3) AIR NOT FIT FOR BREATHING		8) MOVING PARTS
	4) NOISE		9) FAN ROTATING
	5) MACHINE WITH AUTOMATIC START		10) PURGE EVERY DAY

5.1 DESCRIPTION OF COMPULSORY SIGNALS

	11) READ THE USE AND MAINTENANCE INSTRUCTIONS		
---	---	--	--

6.0 DANGERS ZONES

6.1 DANGERS ZONES FOR COMPRESSOR UNIT



Risks present on the whole machine

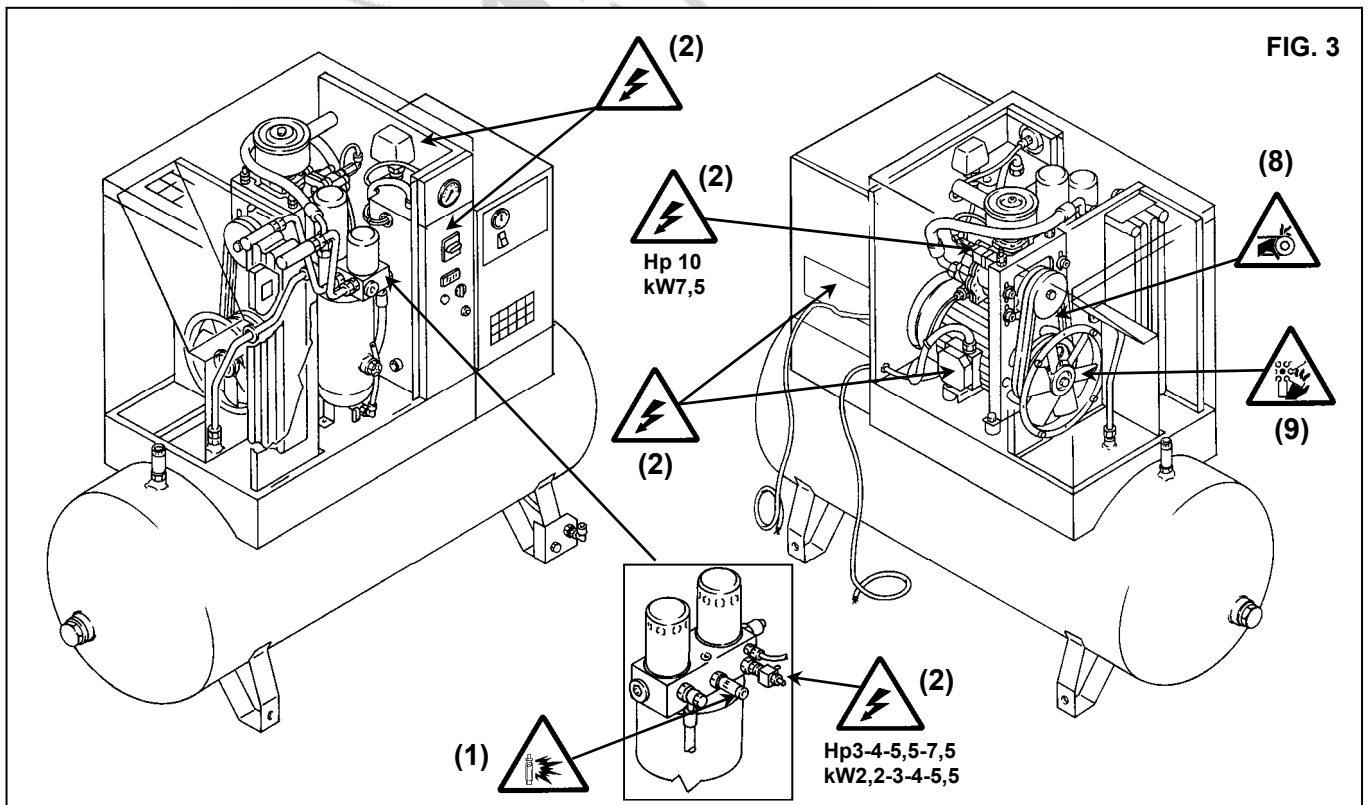

6.2 DANGERS ZONES FOR DRIER UNIT AND TANK



Risks present on the whole machine

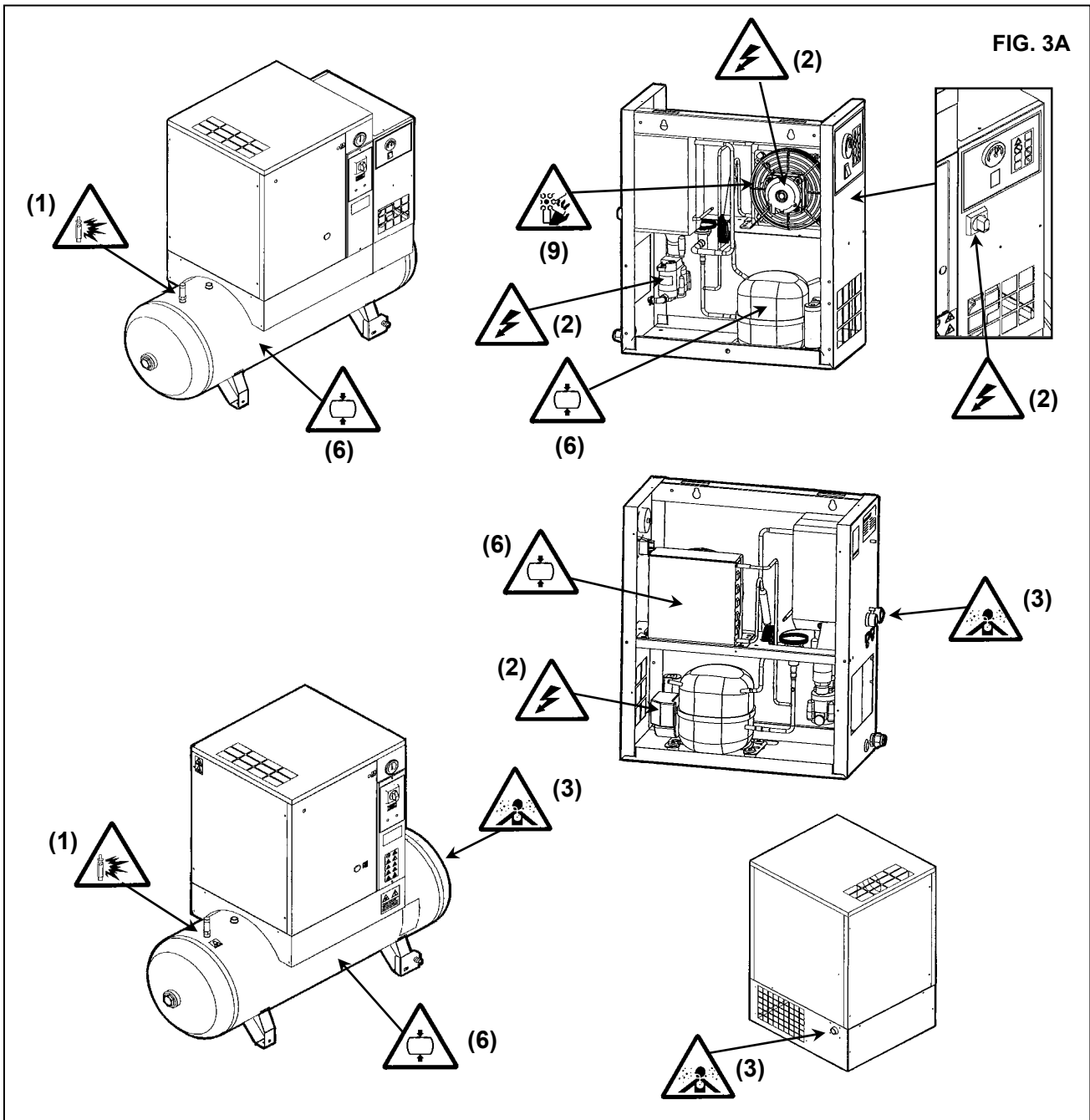
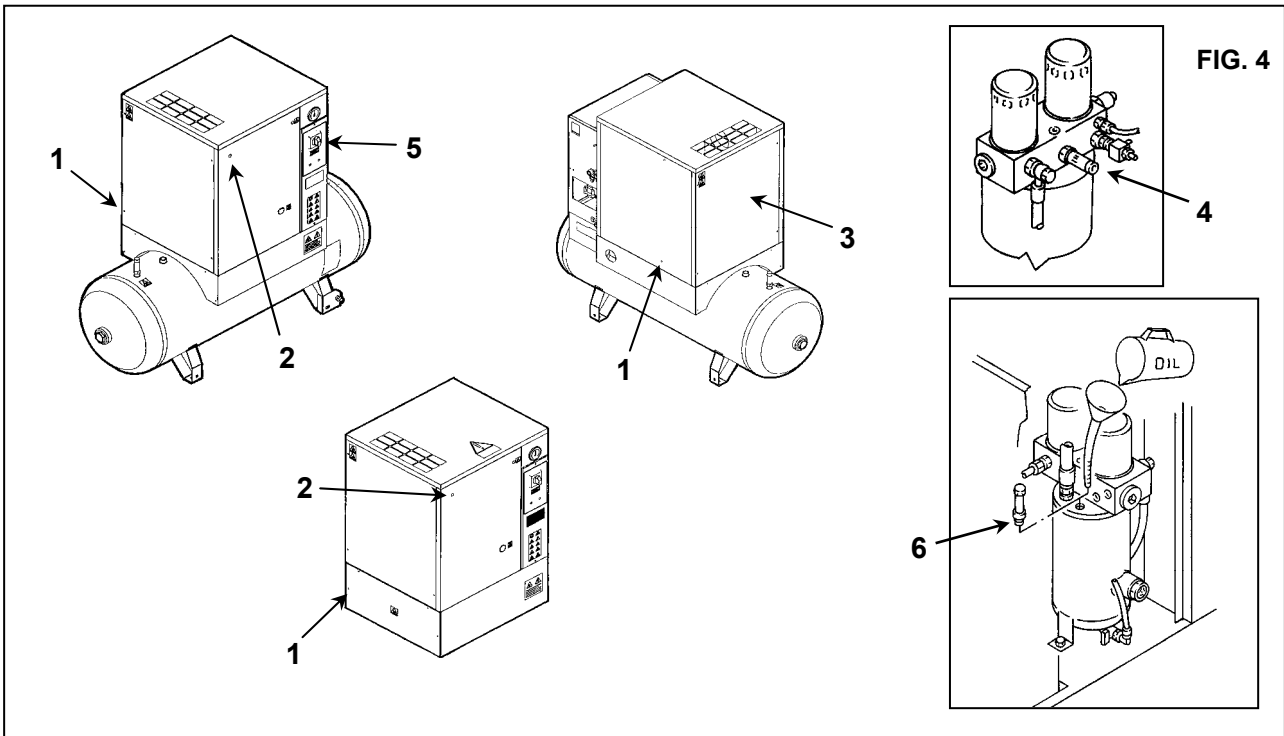

FIG. 3A

7.0 SAFETY DEVICES

7.1 SAFETY DEVICES FOR SCREW COMPRESSOR (Fig. 4)

- 1) Safety screws
- 2) The front protection can be opened with a special key
- 3) Fixed protection device - cooling fan / pulley
- 4) Safety valve
- 5) Emergency stop
- 6) Oil filling cap (with safety breather)



7.2 SAFETY DEVICES FOR DRIER UNIT AND TANK

- 1) Safety valve
- 2) Protective switch cap.
- 3) Protective pressure switch cap.
- 4) Relay for compressor (automatic)
- 5) Overload protector for compressor

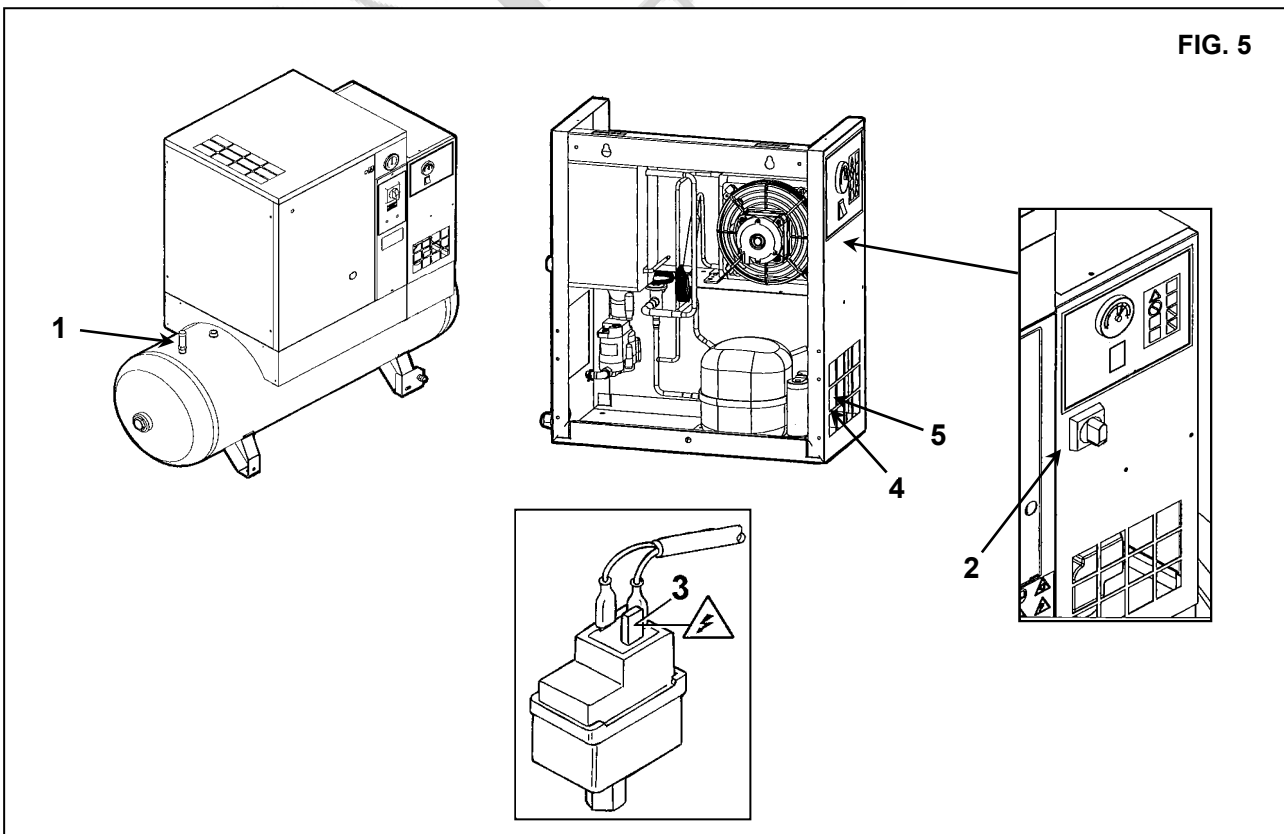

8.0 POSITION OF PLATES

8.1 POSITION OF THE DANGER PLATES FOR COMPRESSOR UNIT

The plates fitted on the compressor unit are part of the machine; they have been applied for safety purposes and must not be removed or spoiled for any reason.

1) Dangers plate Code 2202 2607 91	4) Electrical label Code 2202261071
2) Plate "Machine with automatic start" Code 2202260791	5) Electrical label
3) Electrical label	

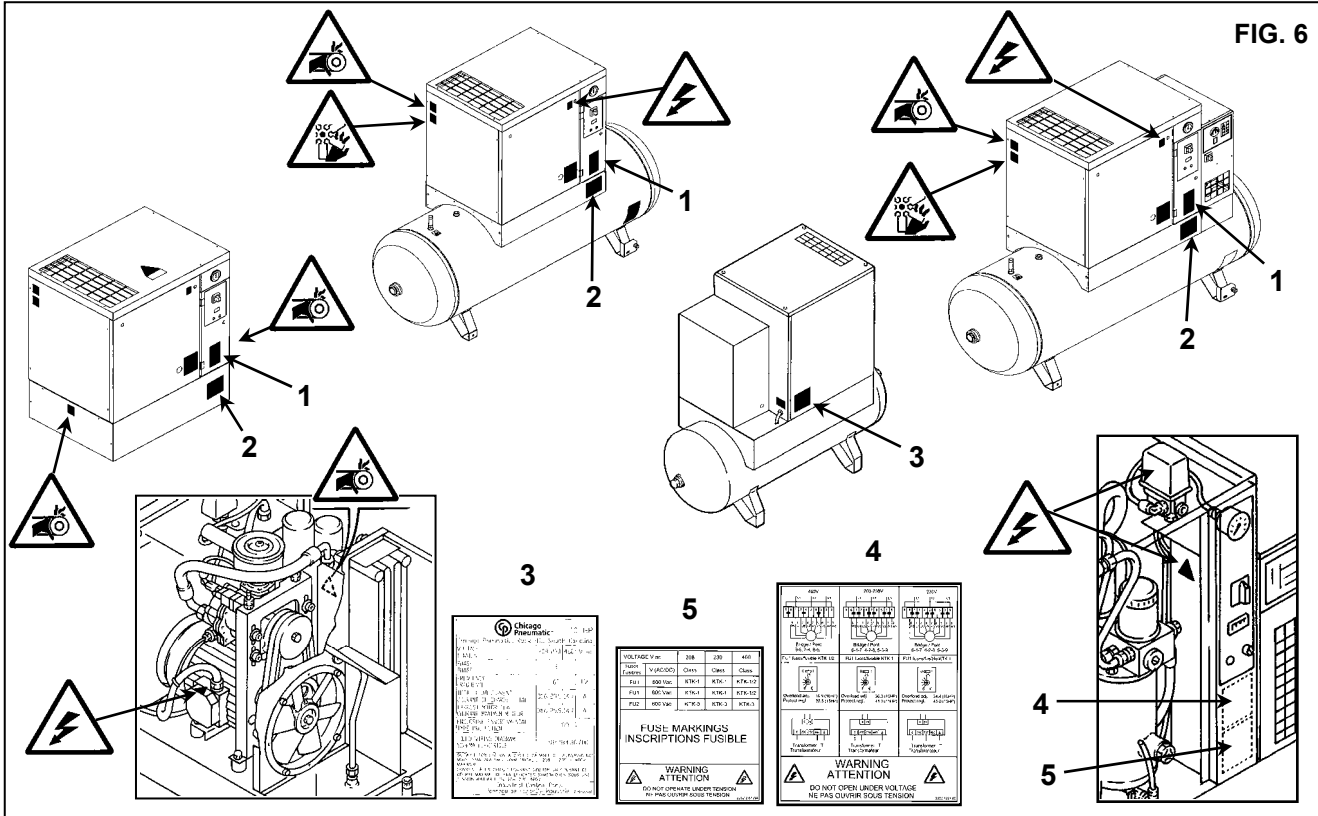

8.2 POSITION OF THE DANGER PLATES FOR DRIER UNIT AND TANK

The plates fitted on the compressor unit are part of the machine; they have been applied for safety purposes and must not be removed or spoiled for any reason.

1) Dangers plate 2202921501	2) Electrical label
-----------------------------	---------------------

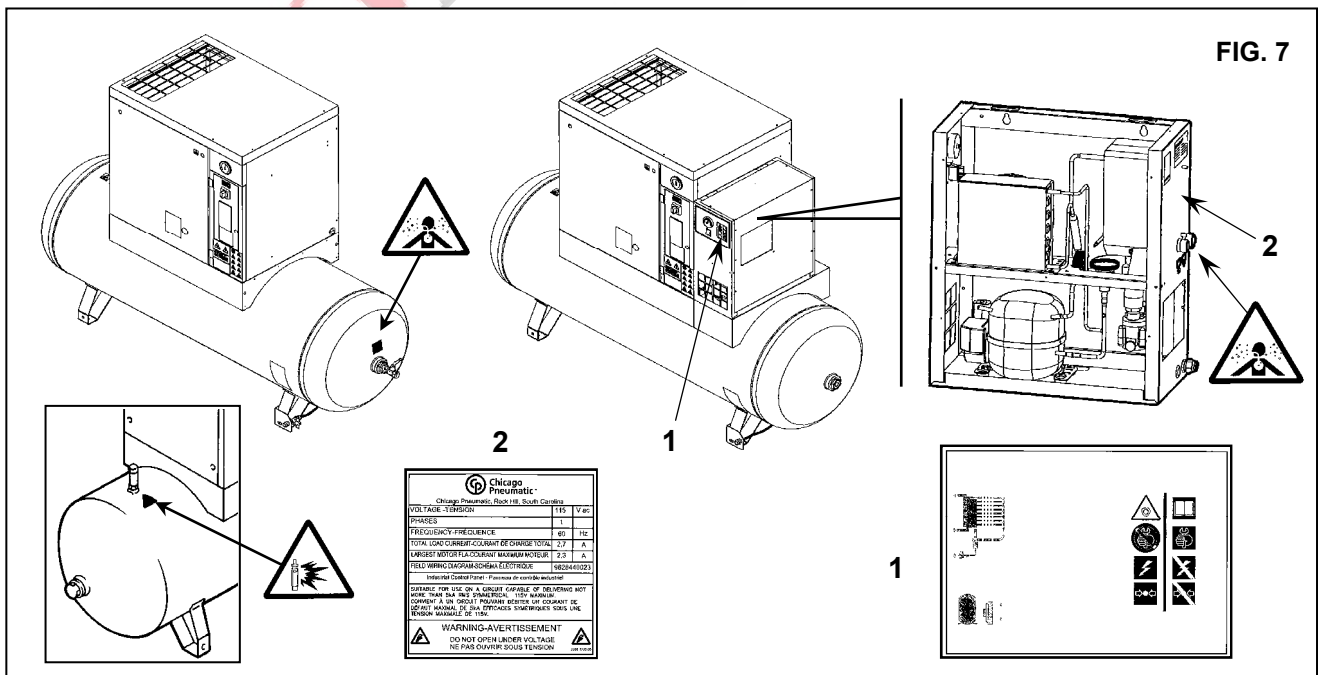

8.3 POSITION OF THE DATA PLATE FOR COMPRESSOR UNIT

FIG. 8

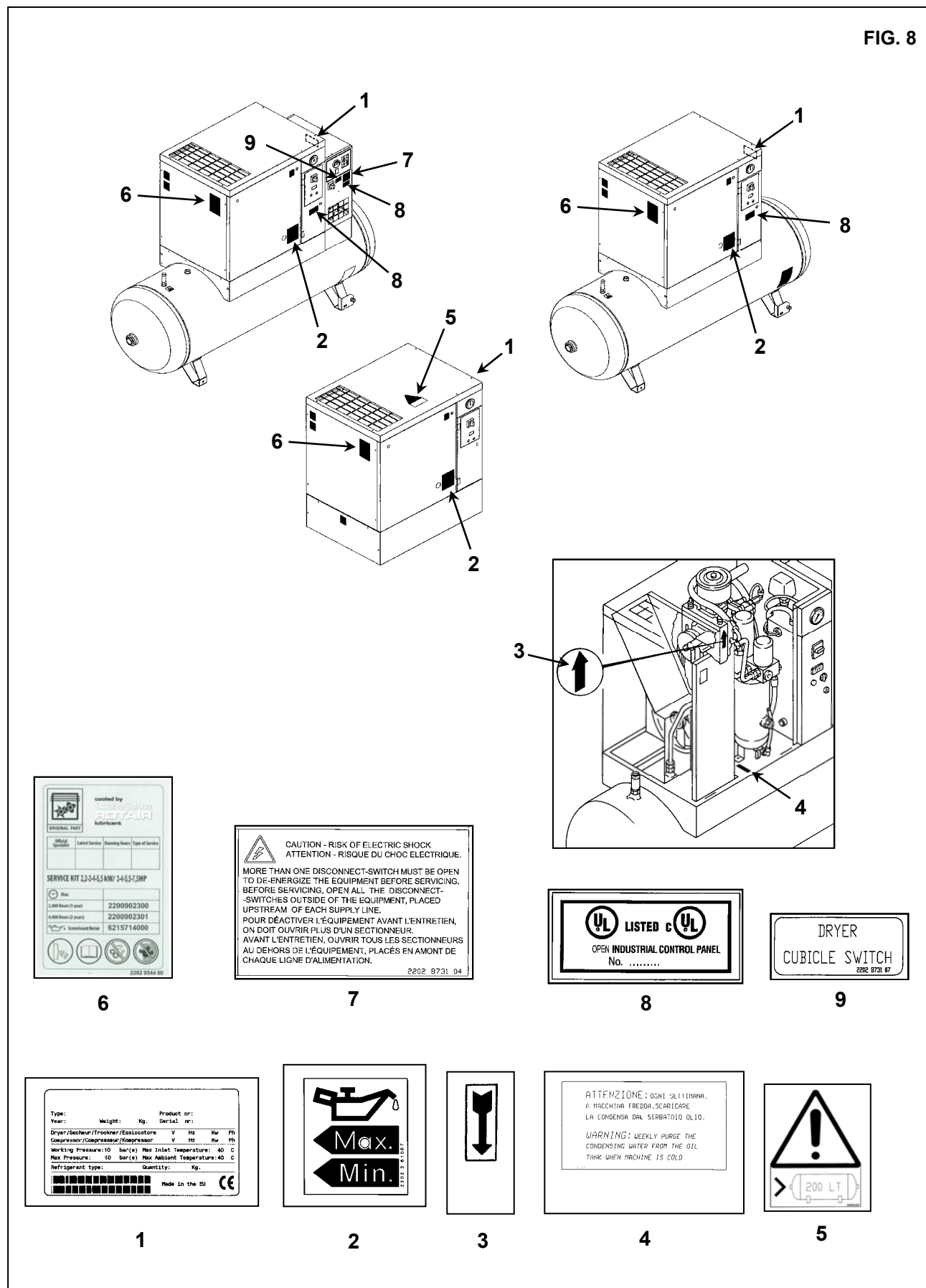

8.4 POSITION OF THE DATA PLATE FOR DRYER – AIR RECEIVER

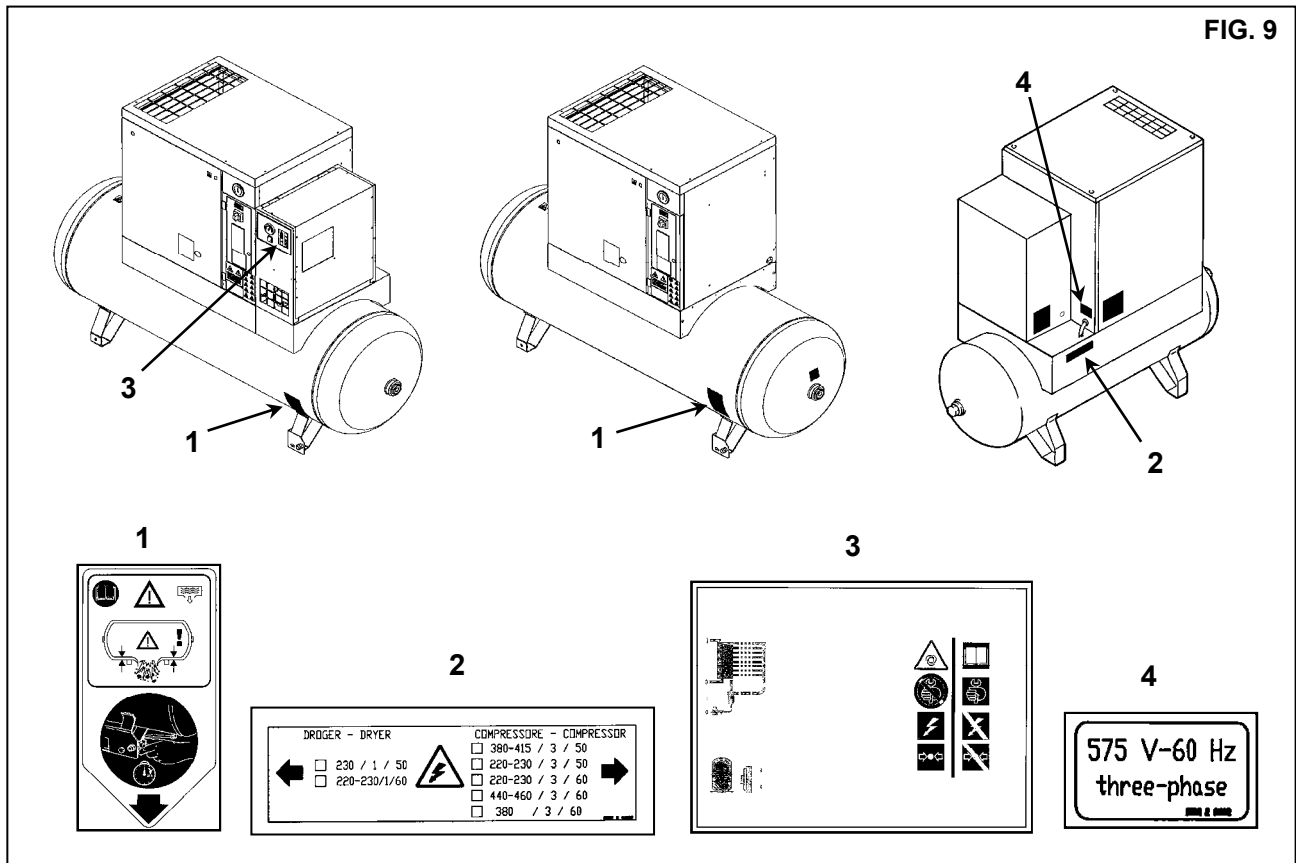

9.0 COMPRESSOR ROOM

9.1 FLOOR

The floor must be even and of industrial type; the total weight of the machine is shown in the Chap. 13.0 Remember the total weight of the machine when positioning it.

9.2 VENTILATION

When the machine is operating, the room temperature must not be higher than **40 °C (104 °F)** or lower than **5 °C (41 °F)**.

The volume of the room must be about **30 m³**

The room must be provided with 2 openings for ventilation with a surface area of about **0,5 m²** each.

The first opening must be in a high position to evacuate the hot air, the second opening must be low to allow the intake of external air for ventilation.

If the environment is dusty it is advisable to fit a filtering panel on this opening.

9.3 EXAMPLES OF VENTILATION OF THE COMPRESSOR ROOM

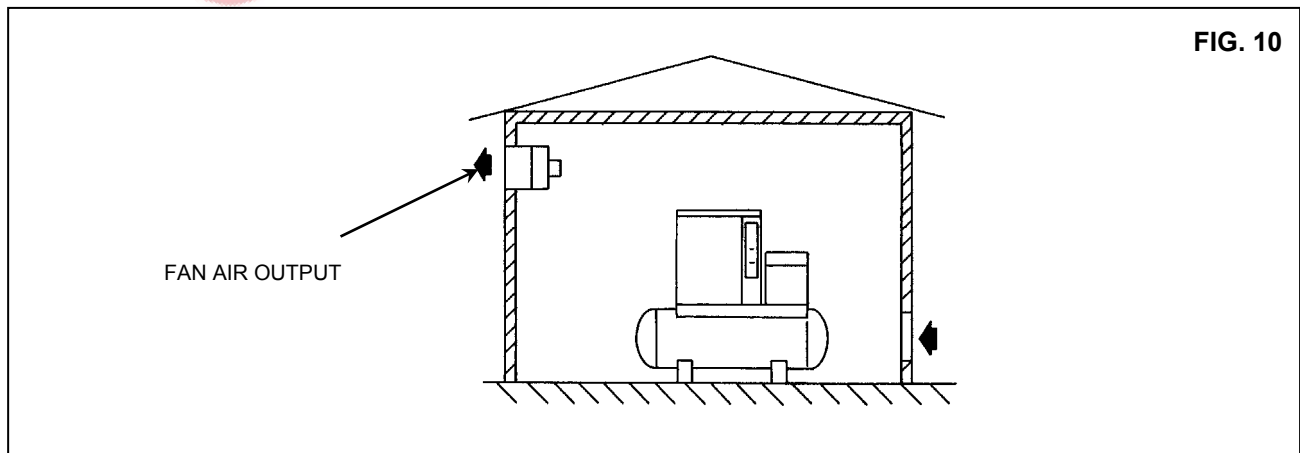

10.0 TRANSPORT AND HANDLING

The machine must be transported as shown in the following figures.

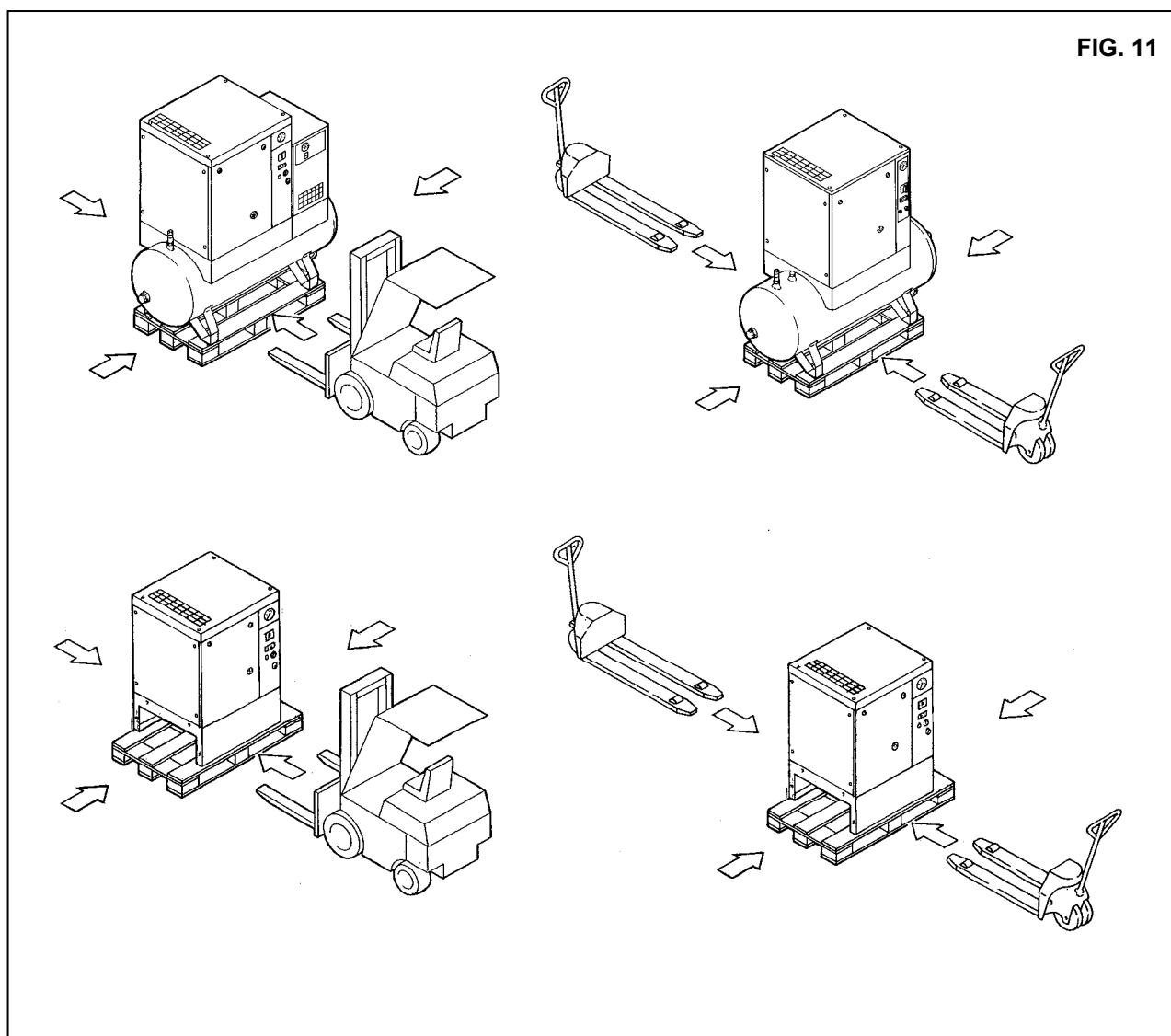
**11.0 UNPACKING**

After removing the packing, ensure that the machine is unbroken and that there are no visibly damaged parts. If you are in doubt, do not use the machine but apply to the manufacturer technical assistance service or to your dealer. The packing material (plastic bags, polystyrene foam, nails, screws, wood, metal strapping, etc..) must not be left within the reach of children or abandoned in the environment, as they are a potential source of danger and pollution. Dispose of these materials in the approved collection centres.

12.0 INSTALLATION

12.1 POSITIONING

After unpacking the equipment and preparing the compressor room, put the machine into position, checking the following items:

- Ensure that there is sufficient space around the machine to allow maintenance (see Fig. 12).
- Check that the compressor is standing on a perfectly flat floor.

FIG. 12

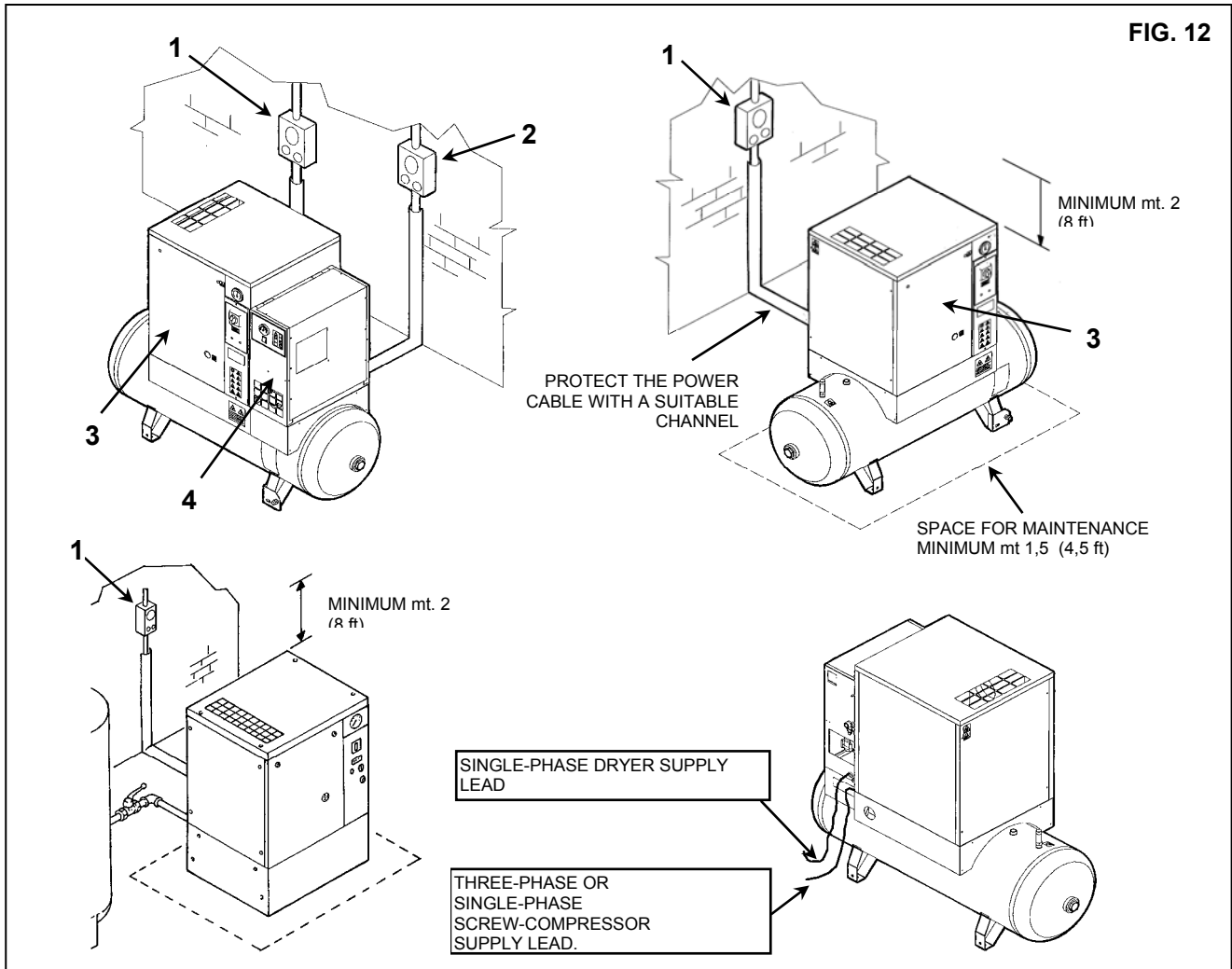

ENSURE THAT THE OPERATOR CAN SEE THE WHOLE MACHINE FROM THE CONTROL PANEL AND CHECK THE PRESENCE OF ANY UNAUTHORIZED PERSONS IN THE VICINITY OF THE MACHINE.

12.2 ELECTRICAL CONNECTION

- Check that the supply voltage is the same as the value indicated on the machine data plate.
CAUTION: the compressor Ref. 3 and the dryer Ref. 4 have two separate feeds, respectively three-phase or single-phase and single-phase.
- Check the condition of the line leads and ensure that there is an efficient earth lead.
- Ensure that there is an automatic cut-out device upstream for the machine against overcurrents, with a differential device (see Ref. 1 for compressor Ref. 2 for dryer) wiring diagram.
- Connect the machine power cables with the greatest care, according to the standards in force.
These cables must be as indicated on the machine wiring diagram.



ONLY PROFESSIONALLY SKILLED PERSONNEL MAY HAVE ACCESS TO THE ELECTRIC PANEL. SWITCH OFF THE POWER BEFORE OPENING THE DOOR OF THE ELECTRIC PANEL.

COMPLIANCE WITH THE REGULATIONS IN FORCE CONCERNING ELECTRIC PLANTS IS FUNDAMENTAL FOR OPERATOR SAFETY AND FOR THE PROTECTION OF THE MACHINE.

CABLES, PLUGS AND ALL OTHER TYPE OF ELECTRIC MATERIAL USED FOR THE CONNECTION MUST BE SUITABLE FOR THE USE AND COMPLYING WITH THE REQUIREMENTS STATED BY THE REGULATIONS IN FORCE.

12.3 CONNECTION TO THE COMPRESSED AIR NETWORK

Fit a manual interception valve Ref. 1 between the machine and the compressed air network so that the compressor may be isolated during maintenance operations; (see figure 13) .



PIPES, FITTINGS AND CONNECTIONS USED FOR THE CONNECTION OF THE ELECTROCOMPRESSOR TO THE COMPRESSED AIR NETWORK MUST BE SUITABLE TO THE USE ACCORDING TO THE PRESCRIPTIONS OF THE REGULATIONS IN FORCE IN THE COUNTRY OF USE.

ALL DAMAGE DUE TO THE FAILURE TO COMPLY WITH THESE INDICATIONS CANNOT BE ATTRIBUTED TO THE MANUFACTURER AND MAY CAUSE INVALIDITY OF THE GUARANTEE CONDITIONS.

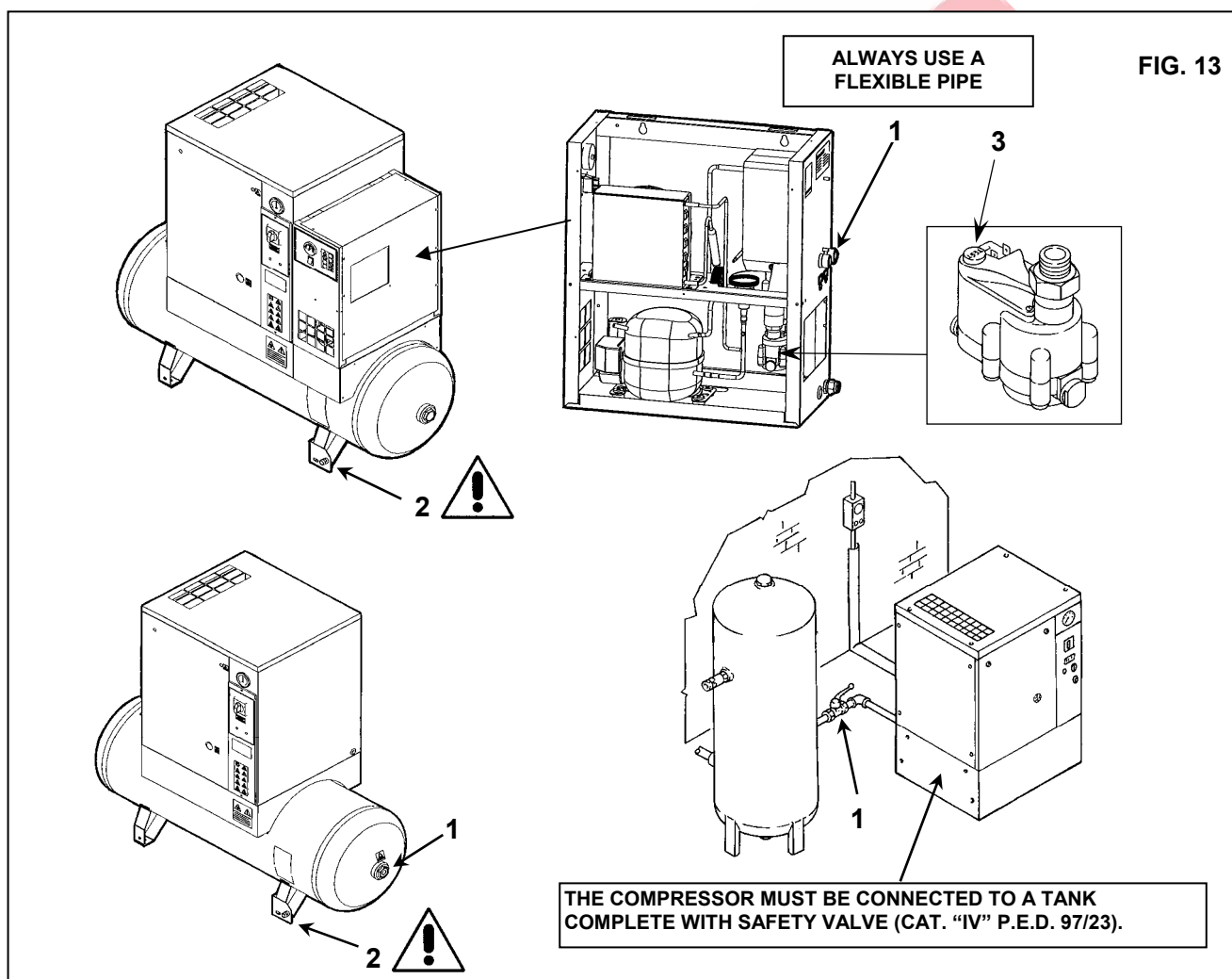

The manual drainage Ref. 2 Fig. 13 the condensate automatic Ref. 3 Fig. 13, are led outside the machine with a flexible pipe that may be inspected. Drainage must comply with the local regulations in force.



ALL DAMAGE DUE TO THE FAILURE TO COMPLY WITH THESE INDICATIONS CANNOT BE ATTRIBUTED TO THE MANUFACTURER AND MAY CAUSE INVALIDITY OF THE GUARANTEE CONDITIONS.

12.4 STARTING UP

See part B of this manual, Chapter 20.0

13.0 DIMENSIONS AND TECHNICAL DATA

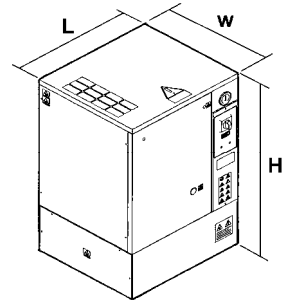
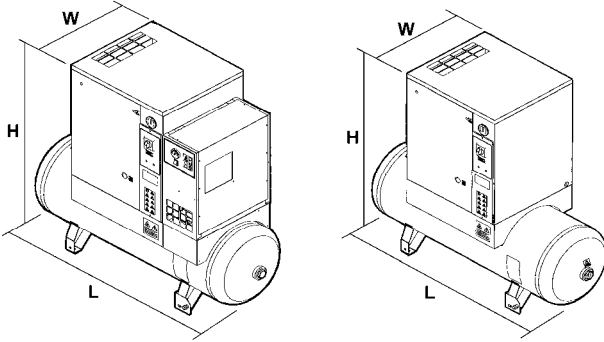

HP 3-5,5-7,5 KW 2,2-3,7-5,5	Dimensions mm (in)			Air connection
	L	W	H	
	1429 (56,2)	612 (24)	1255/1300 (49,4) / (51,1)	1/2"
HP 10 / kW 7,5	1420 (55,9)	648 (25)	1280/1300 (50,3) / (51,1)	

HP 3-5,5-7,5 KW 2,2-3,7-5,5	Dimensions mm (in)			Air connection
	L	W	H	
	620 (24,4)	612 (24)	950/995 (37,4) / (39,1)	3/4"
HP 10 / kW 7,5	620 (24,4)	635 (24,9)	975/995 (38,3) / (39,1)	

	HP 3 kW 2,2	HP 3 kW 2,2	HP 5 kW 3,7	HP 5 kW 3,7	HP 7,5 kW 5,5	HP 7,5 kW 5,5	HP 10 kW 7,5	HP 10 kW 7,5
Setting pressure bar(PSI)	8 (116)	10 (150)	8 (116)	10 (150)	8 (116)	10 (150)	8 (116)	10 (150)
Standard air capacity l/min.	278	240	543	470	668	600	1008	920
Net weight Kg. without dryer (lb)	155 (341,7)		159 (350,5)		164 (361,5)		214 (471,7)	
Net weight Kg. with dryer (lb)	187 (412,2)		193 (425,4)		198 (436,5)		254 (559,9)	
Net weight Kg. on base (lb)	99 (218,2)		105 (231,4)		110 (242,5)		160 (352,7)	
Setting thermostat °C (°F)	105 ÷ 110 (221 ÷ 230) permanent setting							
Oil load Liters	~ 2,5	~ 2,5	~ 2,5	~ 2,5	~ 2,5	~ 2,5	~ 2,7	~ 2,7

TYPE DRYER	Weight Kg. (lb)	R 134a Kg. (lb)		Nominal Power W (HP)		Nominal Power W (HP)		bar MAX.
		50 Hz	60 Hz	50 Hz	60 Hz	50 Hz	60 Hz	
A1	22 (48,5)		0,190 (0,41)		132 (0,177)		27 (0,04)	16 bar (232 PSI)
A2	23 (50,7)		290 (0,64)		195 (0,261)		27 (0,04)	16 bar (232 PSI)
A3	25 (55,1)		350 (0,77)		260 (0,34)		41 (0,05)	16 bar (232 PSI)

Reference conditions:

Ambient temperature 25 °C - (77 °F)
 Inlet air temperature 35 °C - (45 °F)
 Pressure 7 bar (PSI 101,5)
 Dew point in pressure 3 °C - (37,4 °F)

Limit conditions:

Max. ambient temperature 43°C - (109,4 °F)
 Min. ambient temperature 5°C - (41 °F)
 Max. inlet air temperature 55°C - (131 °F)
 Max. working pressure 16 bar - (232 PSI)

14.0 MACHINE ILLUSTRATION**14.1 GENERAL LAY-OUT FOR DRYER AND TANK**

- | | |
|-----------------------------------|--|
| 1 Refrigerant compressor | 8 Expansion capillary tube |
| 2 Condenser | 9 Safety valve (Compressed air tank) * |
| 3 Motor fan | 10 Compressed air tank |
| 4 Evaporator | 11 Condensate manual drainage |
| 5 Condensate drain solenoid valve | |
| 6 Hot gas bypass valve | |
| 7 Refrigerant filter | |

*** IT IS FORBIDDEN TO TAMPER WITH THE SETTING VALUES OF THE SAFETY VALVE**

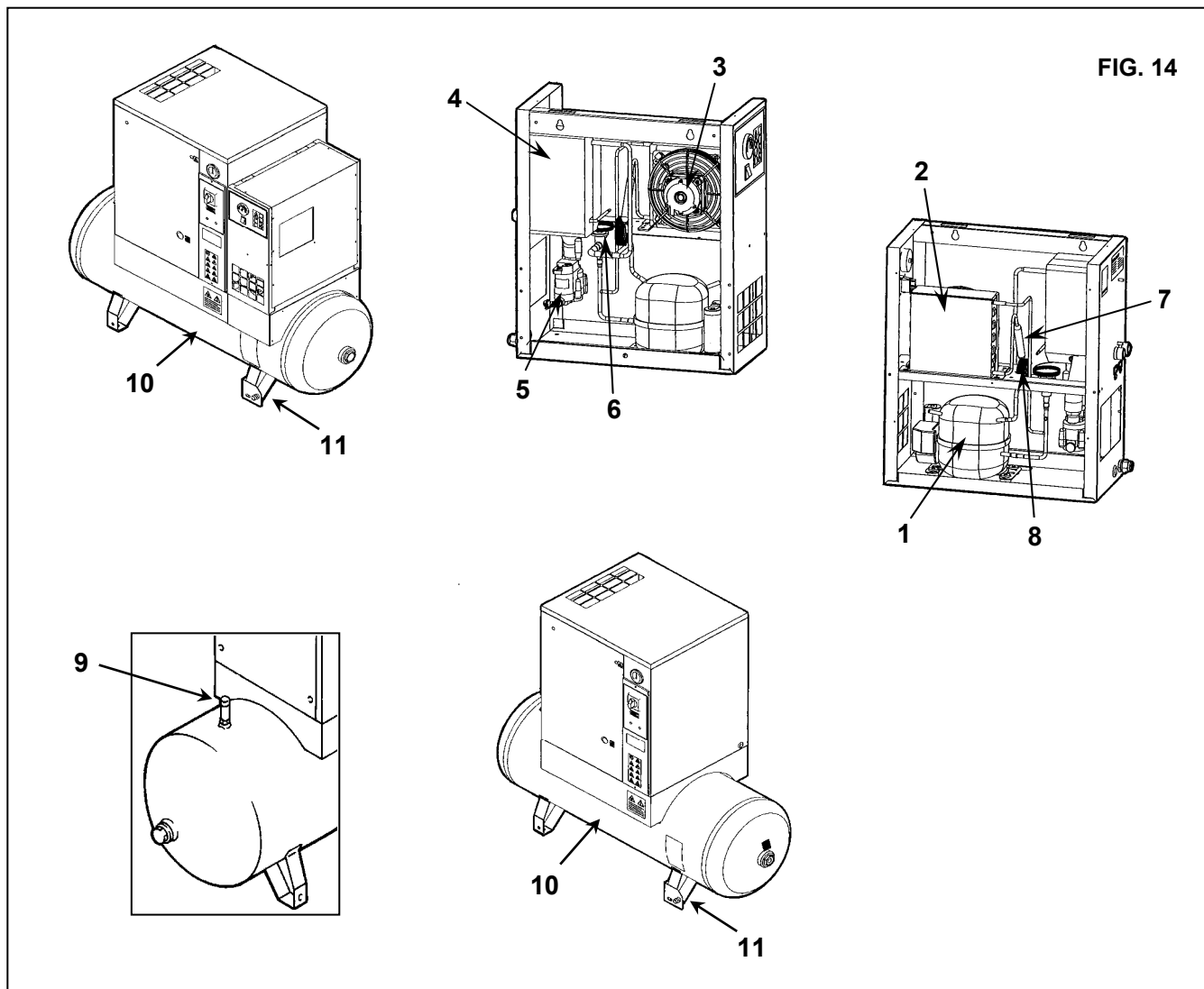

14.2 GENERAL LAY-OUT FOR SCREW COMPRESSOR

- | | |
|--|--|
| 1 Air suction filter | 12 Oil discharge |
| 2 Thermostatic valve | 13 Oil tank |
| 3 Oil filter | 14 Delivery pressure gauge |
| 4 Air-oil cooler | 15 Safety valve * |
| 5 Drain solenoid valve (Hp 3-4-5,5-7,5 / kW 2,2-3-4-5,5) | 16 Electric motor |
| 6 Belt tightening system | 17 Screw compressor |
| 7 Minimum pressure valve | 18 Suction unit |
| 8 Air-oil separator with oil separating filter | 19 Drain solenoid valve (Hp 10 / kW 7,5) |
| 9 Top-up or oil filling cap | |
| 10 Control panel | |
| 11 Oil gauge | |

*** IT IS FORBIDDEN TO TAMPER WITH THE SETTING VALUES OF THE SAFETY VALVE**

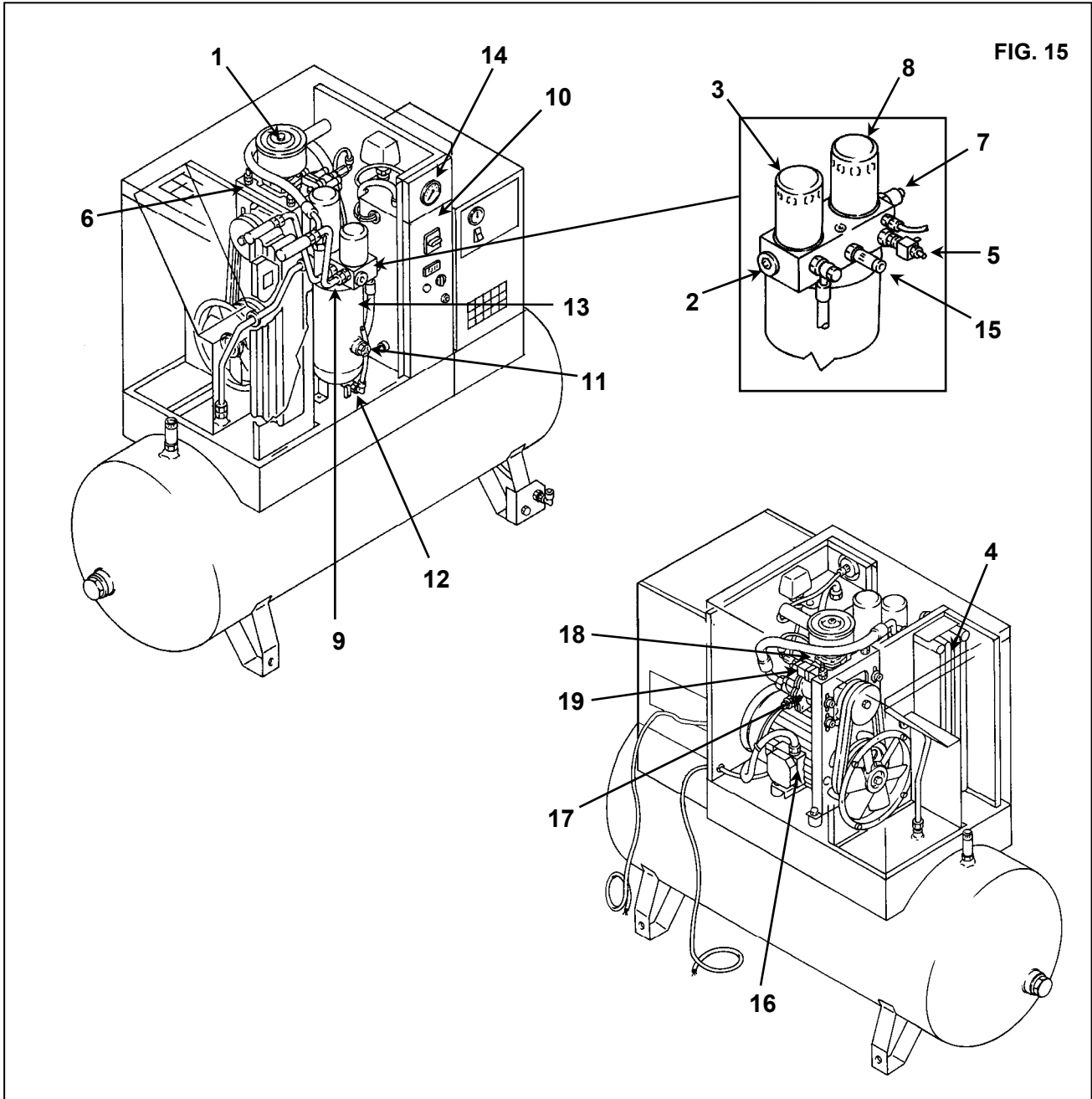

14.3 COMMAND AND CONTROL PANEL



BEFORE CARRYING OUT THE OPERATION TEST, READ CAREFULLY AND ACQUIRE A GOOD KNOWLEDGE OF THE COMMAND FUNCTIONS.

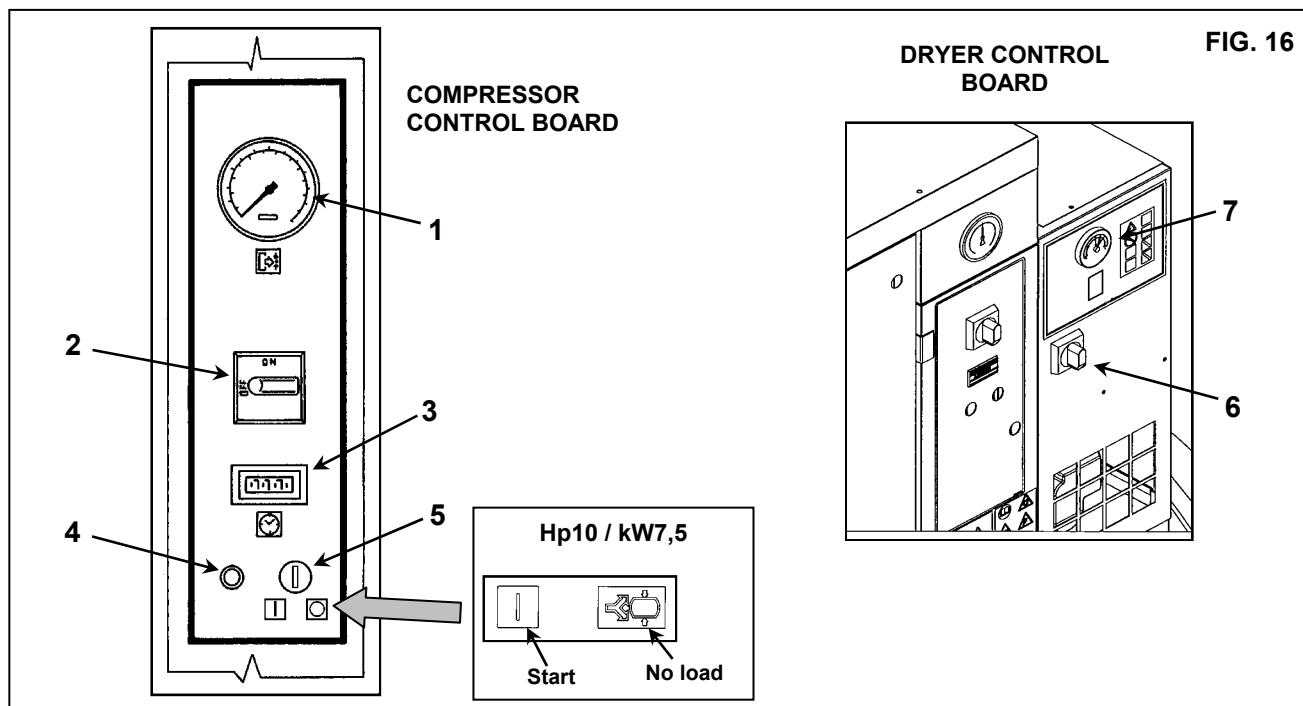

- 1) Delivery pressure gauge
- 2) Isolating switch - **also used as emergency stop and for resetting the motor thermal protection.**
- 3) Work hour counter: indicates the hours of operation
- 4) Operation lamp
- 5) Selector (Start - Stop for Hp3-4-5,5-7,5 / kW2,2-3-4-5,5), Selector (Start - No load for Hp10 / kW7,5).
- 6) "OFF" - "ON" isolating switch dryer
- 7) Dew point indicator



IMPORTANT: WHEN THE SWITCH Ref. 2 and Ref. 6 IS IN POSITION "OFF" THE TERMINALS ARE STILL LIVE.

Hp3-4-5,5-7,5 / kW2,2-3-4-5,5

- STARTING:**
- Move the selector Ref. 2 to position "ON".
 - Move the selector Ref. 5 to position "I"; the selector will return automatically.
 - The compressor starts running, operation lamp Ref. 4 lights up.

- STOPPING:**
- Move the selector Ref. 5 to position "0"
 - Lamp Ref. 4 goes out.
 - Move the selector Ref. 2 to position "OFF".

Hp10 / kW7,5

- STARTING:**
- Move the selector Ref. 2 to position "ON".
 - Move the selector Ref. 5 to position "I"; the selector will return automatically.
 - The compressor starts running, operation lamp Ref. 4 lights up.

- STOPPING:**
- Move the selector Ref. 5 to position "0"
 - Wait at least 30 seconds..
 - Move the selector Ref. 2 to position "OFF".



CAUTION: WAIT AT LEAST 30 SECONDS BEFORE STARTING THE MACHINE AFTER SWITCH OFF.

15.0 ORDINARY MAINTENANCE TO BE DONE BY THE USER



BEFORE CARRYING OUT ANY MAINTENANCE IT IS OBLIGATORY TO STOP THE MACHINE AND DISCONNECT IT FROM THE POWER MAINS AND FROM THE COMPRESSED AIR DISTRIBUTION NETWORK.

The maintenance jobs described in this chapter may be carried out by the user. The more complex maintenance jobs which require professionally skilled personnel are listed in the chapter on **GENERAL ROUTINE MAINTENANCE**. (See Chap. 21.0)

15.1 MAINTENANCE PROGRAMME

- OPERATIONS THAT MAY BE CARRIED OUT BY THE USER
- ■ OPERATIONS THAT REQUIRE SKILLED PERSONNEL; THESE OPERATIONS ARE ILLUSTRATED IN PART "B" OF THIS MANUAL.

These maintenance intervals are recommended for work environments that are not dusty and are well ventilated. For particularly dusty environments, double the frequency of controls.

Every Day (after use)	<ul style="list-style-type: none"> ■ Drain condensate from the air tank ■ Check automatic condensation emptying (dryer)
Every 50 working hours	<ul style="list-style-type: none"> ■ Drain condensate from the oil tank ■ Check the oil level
Every 500 hours	<ul style="list-style-type: none"> ■ Clean the air suction filter ■ Clean the condenser battery (on the dryer if fitted) ■ Clean the dirt collection filter ■ ■ Check belt tension
Every 2000 hours	<ul style="list-style-type: none"> ■ Change the suction filter ■ ■ Change the oil (*) ■ ■ Change the oil filter
Every 4000 hours	<ul style="list-style-type: none"> ■ ■ Clean the finned surface of the air-oil cooler ■ ■ Change the oil separating filter

* It is recommended that the compressor oil be changed once per year, regardless of the number of hours of operation. Oil must be changed more frequently than once per year if the compressor is installed in a dirty environment.

15.2 DRAINING CONDENSATE FROM THE OIL TANK

If the compressor work cycle contemplates long pauses during which the machine cools down, a certain amount of condensate will gather in the oil tank. This happens, for example, when stopping overnight or at weekends. The condensate must be drained off every 50 hours **or every week**. This operation may be performed only when the machine is cold, that is when it has been switched off for at least 8 hours.



BEFORE DRAINING THE CONDENSATE IT IS OBLIGATORY TO STOP THE MACHINE AND DISCONNECT IT FROM THE POWER MAINS.

Proceed as follows:

- Stop the machine, (See pag. 17).
- Stop the dryer turning in "OFF" position the isolating switch Rif. 2 Fig. 17 (on the dryer if fitted).
- Turn on the differential supply switch, Ref. 3 (on the screw-compressor) and Ref. 4 (on the dryer if fitted) Fig. 17.

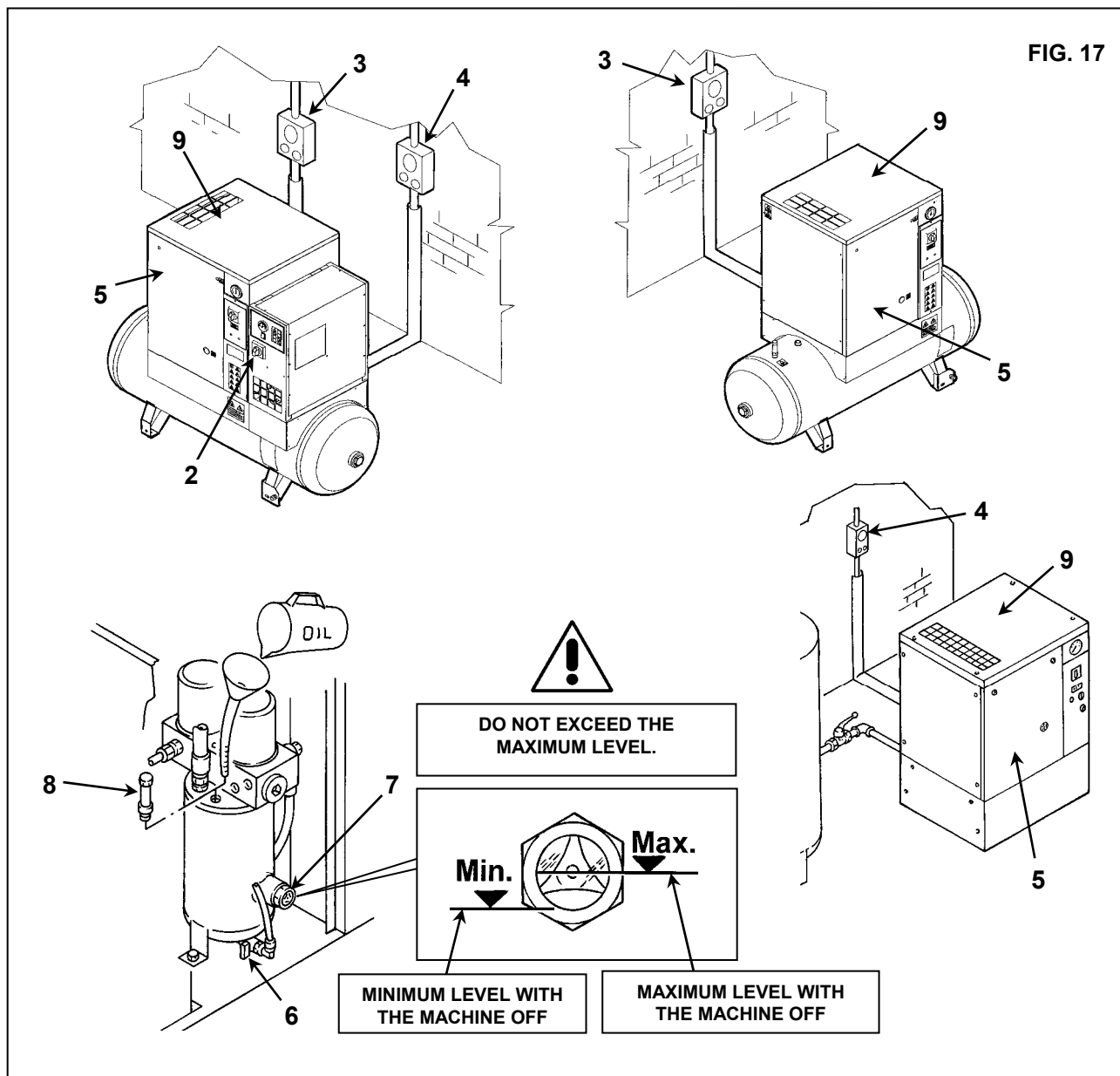

ENGLISH

- Wait for the machine to cool down.
- Remove the panel Ref. 5 Fig. 17 with the key provided.
- SLOWLY turn on the tap Ref. 6 Fig. 17 and let the condensate flow out.
- When the first traces of oil appear, turn off the tap.



CONDENSATE MUST BE DISPOSED OF IN CONFORMITY WITH THE LOCAL REGULATIONS IN FORCE.

- Check the oil level on the indicator Ref. 7 Fig. 17.
- If the oil level is under the minimum, top up as described at point 15.3.



USE OIL OF THE SAME TYPE AS THAT ALREADY IN THE MACHINE; DO NOT MIX DIFFERENT TYPES OF OIL

15.3 CHECK OIL LEVEL AND TOP UP

- Stop the machine, (**See pag. 17**).
- **WAIT A FEW MINUTES FOR THE FOAM IN THE OIL COLLECTOR TO ABATE.**
- Check the oil level on the indicator Ref. 7 Fig. 17.
- If the oil level is below minimum, fill up as follows
- Stop the dryer turning in "OFF" position the isolating switch Rif. 2 Fig. 17 (on the dryer if fitted)
- Turn on the differential supply switch, Ref. 3 (on the screw-compressor) and Ref. 4 (on the dryer if fitted) Fig. 17.



USE OIL OF THE SAME TYPE AS THAT ALREADY IN THE MACHINE; DO NOT MIX DIFFERENT TYPES OF OIL.



BEFORE CARRYING OUT ANY OPERATION ON THE MACHINE, ENSURE THAT THE ELECTRIC POWER SUPPLY HAS BEEN DISCONNECTED.

- Open the front protection Ref. 5 Fig. 17 using the special key.
- Remove the fixed protection device (machine cover) Ref. 9 Fig. 17.
- Slowly unscrew the oil cap Ref. 8 Fig 17, ensuring there is no pressure inside.
- Top up to maximum level Ref. 7 Fig. 17, with oil of the same type in the compressor.
- Close the oil manifold cap Ref. 8 Fig. 17.
- Close the fixed protection (machine cover) Ref. 9 Fig. 17 device again, using the appropriate safety screws.
- Close the front protection Ref. 5 Fig. 17.

15.4 CLEANING THE FILTERING PANEL

- Stop the machine, (**See pag. 17**).
- Turn on the differential supply switch Rif. 3 Fig. 18.
- Clean the filtering panel Rif. 1 Fig. 17A with a jet of air wash it with water, **do not use solvents.**

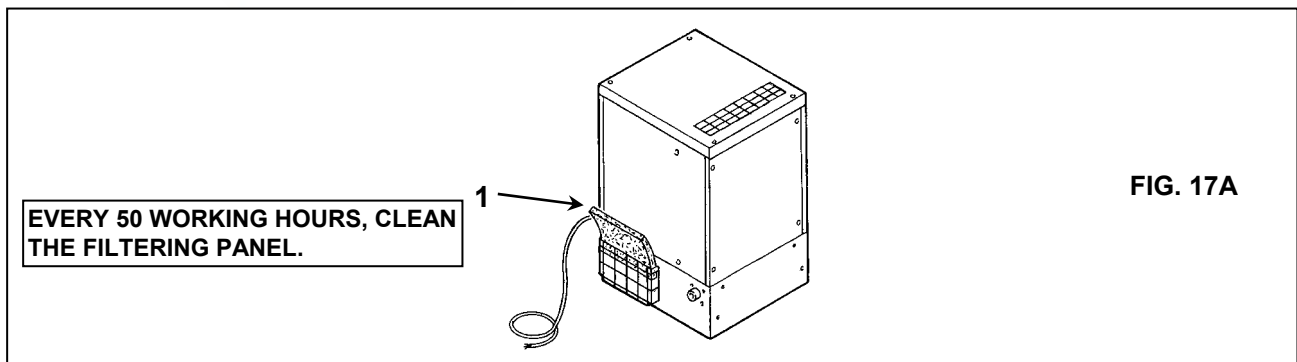

15.5 CLEANING THE SUCTION FILTER OR CHANGING THE FILTER

- Stop the machine, (See pag. 17).
- Stop the dryer turning in "OFF" position the isolating switch Rif. 3 Fig. 17
- Turn on the differential supply switch, Ref. 3 (on the screw-compressor) and Ref. 4 (on the dryer if fitted) Fig. 18.



HOT PARTS INSIDE

- Remove the fixed protection device (machine cover) Ref. 5 Fig. 18.
- Remove the cover Ref. 6 Fig. 18 (Check the direction of the arrow).
- Remove the filter Ref. 7 Fig. 18.

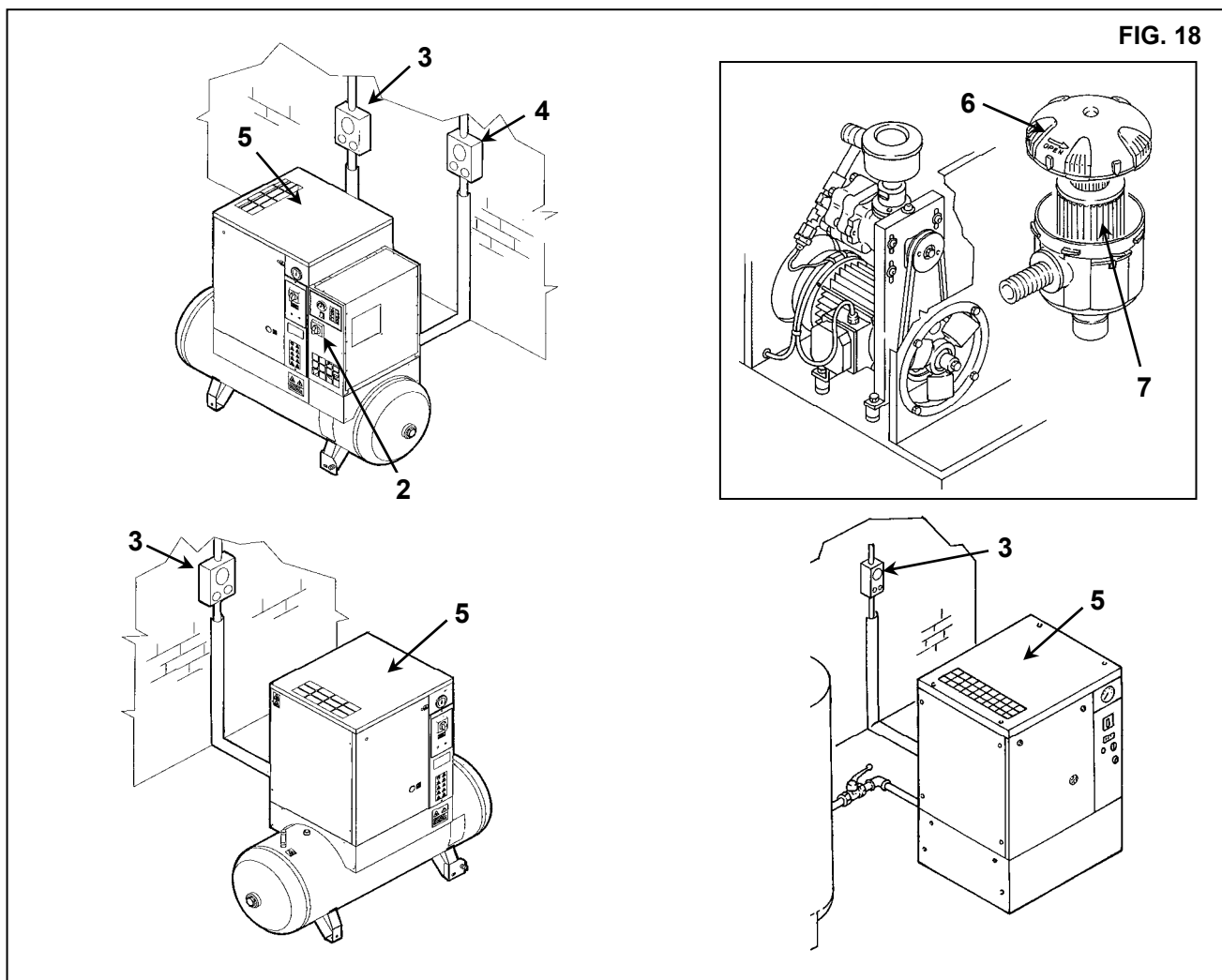

AVOID DROPPING FOREIGN BODIES INTO THE SUCTION MANIFOLD.

- Clean the filter with a jet of air, working from inside to outside, **DO NOT USE WATER OR SOLVENTS**. Alternatively, fit a new filter.
- Clean the disk on which the filter rests with a clean cloth.
- Fit the filter and the cover
- If necessary, dispose of the old filter in conformity with the local regulations in force.
- Close the fixed protection (machine cover) Ref. 5 Fig. 18 device again, using the appropriate safety screws.

15.6 CHECKING THE AUTOMATIC AND MANUAL CONDENSATION EMPTYING (FOR DRYER AND TANK)



BEFORE CARRYING OUT ANY MAINTENANCE IT IS OBLIGATORY TO STOP THE MACHINE AND DISCONNECT IT FROM THE POWER MAINS AND FROM THE COMPRESSED AIR DISTRIBUTION NETWORK.

The automatic and manual condensation drain must be checked (Ref. 8 every 500 hours and Ref. 11 every 24 working hours) Fig. 19.

Proceed as follows:

- Press the "TEST" button, Ref. 8 Fig. 19, for a few seconds to check if the condensation is correctly emptied from the drainage pipe
- Check manual condensation emptying from the tank, to ensure that condensation is correctly emptied from the valve, Ref. 11 Fig. 19 (**PURGE EVERY DAY**).

15.7 CLEANING THE CONDENSER BATTERY (FOR DRYER)



BEFORE CARRYING OUT ANY MAINTENANCE IT IS OBLIGATORY TO STOP THE MACHINE AND DISCONNECT IT FROM THE POWER MAINS AND FROM THE COMPRESSED AIR DISTRIBUTION NETWORK.

The condenser must be cleaned every month (Ref. 6 Fig. 19).

Proceed as follows:

- Stop the machine, (**See pag. 17**).
- Stop the dryer turning in "OFF" position the isolating switch Rif. 3 Fig. 17
- Turn on the differential supply switch, Ref. 3 (on the screw-compressor) and Ref. 4 (on the dryer if fitted) Fig. 19.



HOT PARTS INSIDE

- Remove the protection Ref. 5 Fig. 19
- Clean the condenser fins Ref. 6 Fig. 19 with compressed air (see Fig. A). **DO NOT USE WATER OR SOLVENTS.**
- Close the protection Ref. 5 Fig. 19.

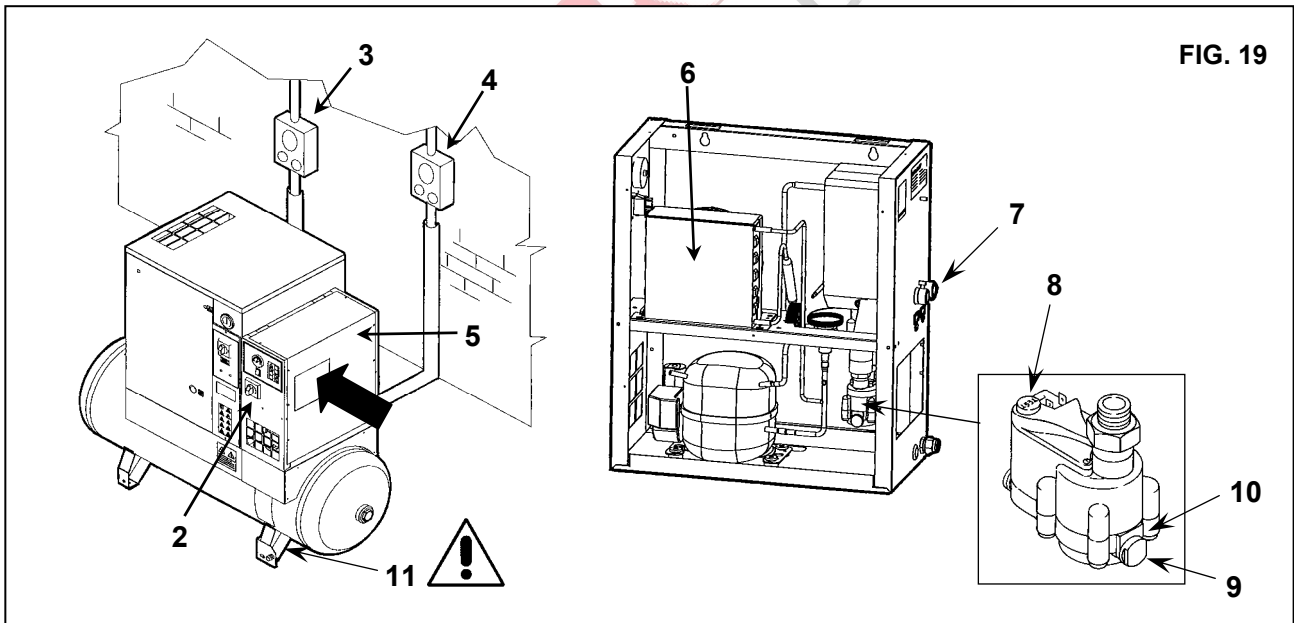

15.8 CLEAN THE DIRT COLLECTION FILTER FOR DRYER (Ref. 9 - 10 Fig. 19)



BEFORE CARRYING OUT ANY MAINTENANCE IT IS OBLIGATORY TO STOP THE MACHINE AND DISCONNECT IT FROM THE POWER MAINS AND FROM THE COMPRESSED AIR DISTRIBUTION NETWORK.

Proceed as follows:

- Close the cock Ref. 7 Fig. 19

- Stop the machine, (**See pag. 17**).
- Stop the dryer turning in "OFF" position the isolating switch Rif. 2 Fig. 17
- Turn on the differential supply switch, Ref. 3 (on the screw-compressor) and Ref. 4 (on the dryer) Fig. 19.
- Remove pressure from the dryer and tank by opening the condensation outlet valve Ref. 11 Fig. 19.
- Remove the stopper Ref. 9 Fig. 19
- Remove the filter Ref. 10 Fig. 19
- Clean the filter Ref. 10 Fig. 19 with a jet of air, working from inside to outside.
- Install the filter, fix the plug.

16.0 PERIODS OF INACTIVITY

If the machine has to remain inactive for a long period:

- Close the tap Ref. 1 and Ref. 2 Fig. 20.
- Stop the machine, (**See pag. 17**).
- Press the button switch Ref. 5 Fig. 20 (on the dryer if fitted)
- Turn on the differential supply switch, Ref. 6 (on the screw-compressor) and Ref. 7 (on the dryer if fitted) Fig. 20.
- Remove pressure from the dryer and tank by opening the condensation outlet valve Ref. 8 Fig. 20.
- Close the taps Rif. 8 Fig. 20 off again after discharging all the residual air pressure.

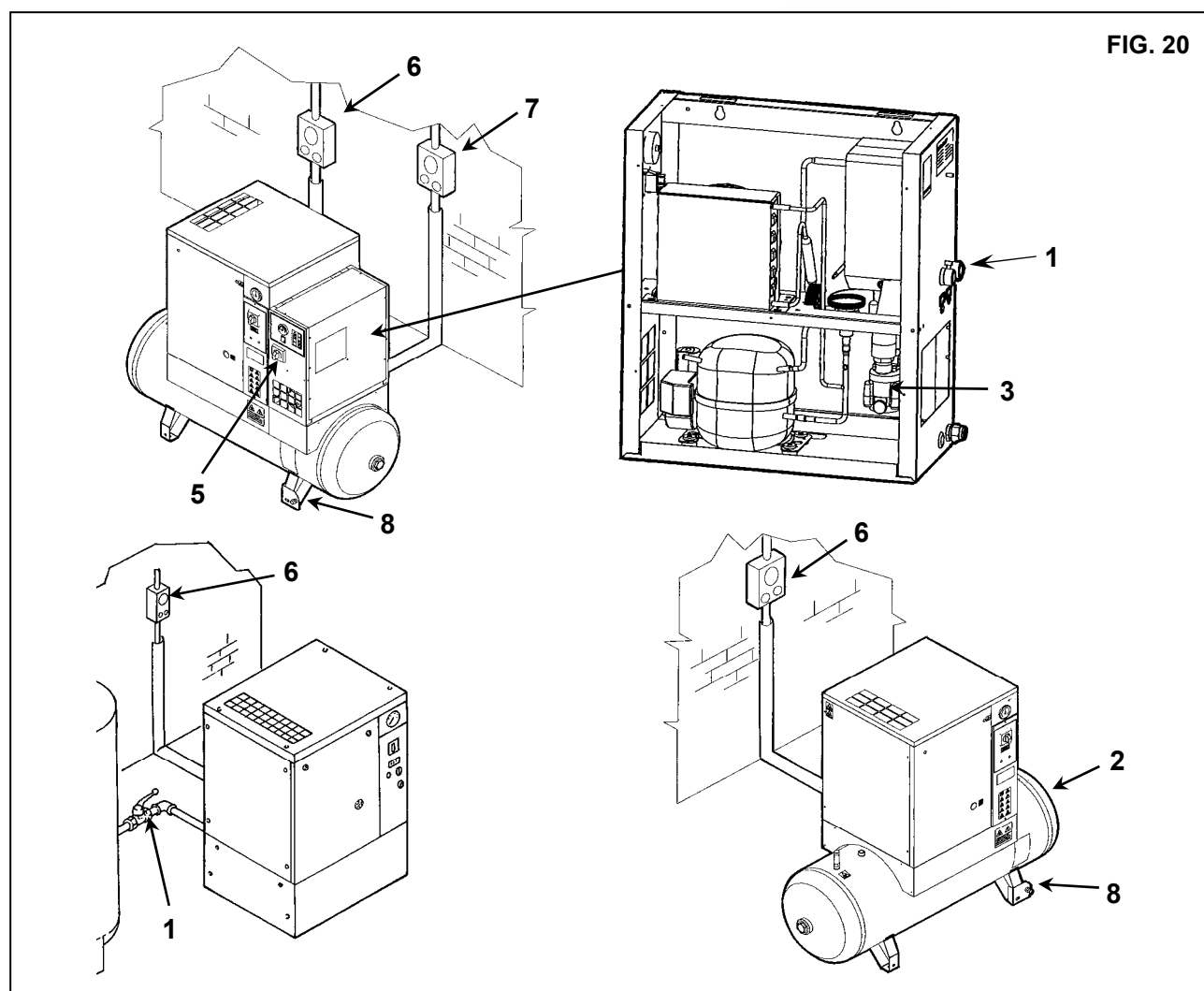

During periods of inactivity the weather must be protected against atmospheric agents, dust and humidity which could damage the motor and the electrical system.

To restart the machine after periods of inactivity, consult the manufacturer.

17.0 SCRAPPING THE UNIT

If the machine is to be scrapped, it must be dismantled into parts of the same material, to be disposed of according to the local regulations in force.



ALWAYS RESPECT THE REGULATIONS IN FORCE FOR DISPOSING OF OLD OIL AND OTHER POLLUTING MATERIALS SUCH AS SOUND-DEADENING, INSULATING FOAM, ETC.

18.0 LIST OF SPARE PARTS FOR ROUTINE MAINTENANCE

Ref.	DESCRIPTION	Code	Q.ty	HP 3 kW 2,2		HP 5 kW 3,7		HP 7,5 kW 5,5		HP 10 kW 7,5	
				8 bar (116 PSI)	10 bar (145 PSI)	8 bar (116 PSI)	10 bar (145 PSI)	8 bar (116 PSI)	10 bar (145 PSI)	8 bar (116 PSI)	10 bar (145 PSI)
1	Suction air filter	6211473750	1	•	•	•	•	•	•		
1	Suction air filter	6211473950	1							•	•
2	Oil filter	6211472650	1	•	•	•	•	•	•		
2	Oil filter	6211472550	1							•	•
3	Separator cartridge	6221372650	1	•	•	•	•	•	•		
3	Separator cartridge	6221372850	1							•	•
4	Filtering panel	2202260700	1	•	•	•	•	•	•	•	•
5	Filter-air-asy.	6211473650	1	•	•	•	•	•	•		
5	Filter-air-asy.	6211473850	1							•	•
6	Belt	0367010056	1	•							
6	Belt	0367010059	2							•	
6	Belt	0367010060	2								•
6	Belt	0367010055	1		•		•				
6	Belt	0367010063	1			•					
6	Belt	0367010058	1					•			
6	Belt	0367010057	1						•		
-	5 Liter Rotair	6215714000	-	•	•	•	•	•	•	•	•

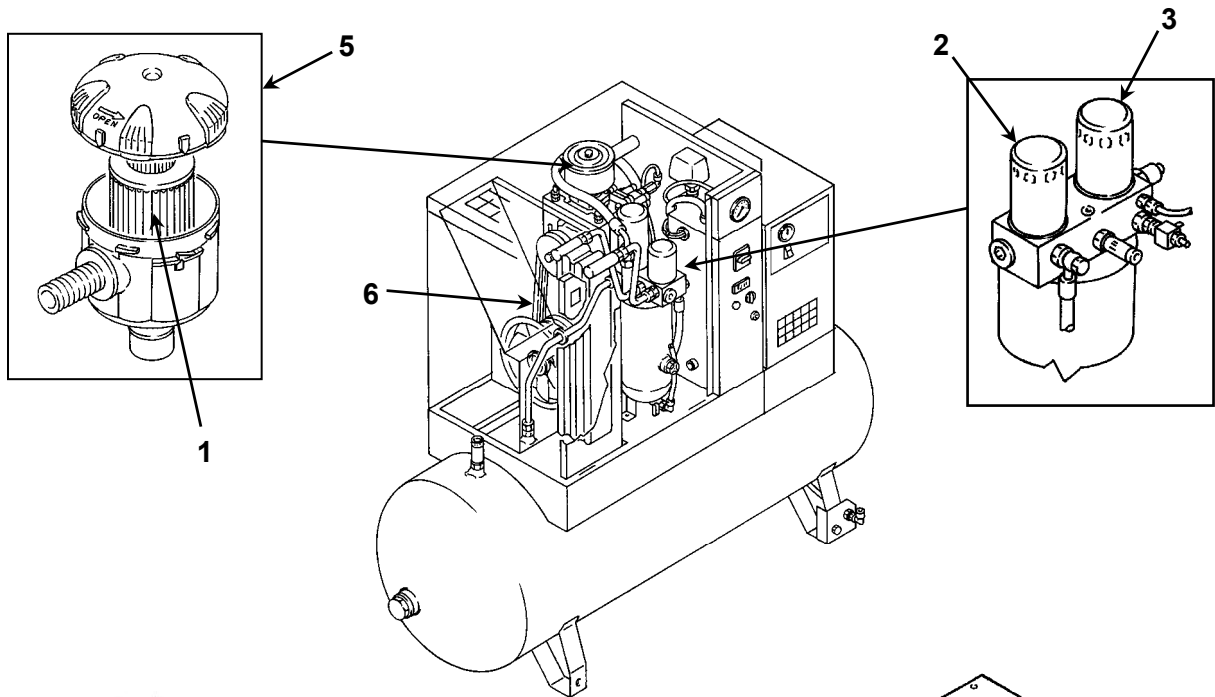

COMPRESSED
AIR ADVISORS

Inc.

Compressed Air Advisors, Inc.

Phone: 877.247.2381

info@compressedairadvisors.com

www.compressedairadvisors.com

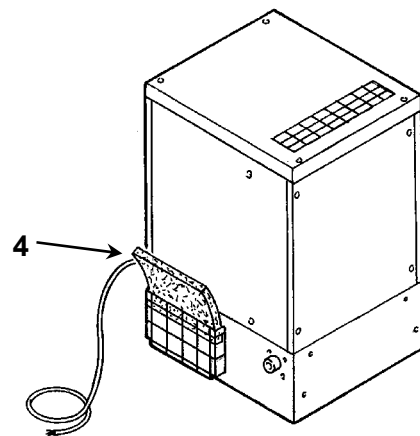

19.0 TROUBLE-SHOOTING AND EMERGENCY REMEDIES

N.B. OPERATIONS MARKED ■ ■ MUST BE CARRIED OUT BY PROFESSIONALLY SKILLED PERSONNEL APPROVED THE MANUFACTURER



ALL WORK MUST BE CARRIED OUT BY PROFESSIONALLY SKILLED PERSONNEL. BEFORE CARRYNG OUT ANY MAINTENANCE JOBS IT IS OBLIGATORY TO STOP THE MACHINE AND DISCONNECT IT FROM THE POWER MAINS.

19.1 TROUBLE-SHOOTING AND EMERGENCY REMEDIES FOR SCREW COMPRESSOR

FAULT FOUND	POSSIBLE CAUSES	OBSERVATIONS
1) The machine does not start	1A - no power 1B - the transformer protection fuse is broken	<ul style="list-style-type: none"> - check the power supply line, Chapter 12.2 - replace fuse
2) The machine does not start	2A - the thermal protection in the main engine has triggered	- To rearm, turn the isolation switch to "OFF" / "ON".
3) The machine does not start	3A - the oil-overheating thermostat has triggered.	<ul style="list-style-type: none"> - environment temperature too high; improve ventilation in the compressor room, Chapter 9.2 ■ ■ - cooling radiator is dirty, clean the radiator - oil level too low; top up the oil tank
4) The compressor does not reach working pressure	4A - the compressed air consumption is too high 4B - the discharge electrovalve remains open, Ref. EV/SC wiring diagram	■ ■ - check the electric system
5) Excess oil consumption	5A - deteriorated oil separating filter oil level is too high	■ ■ - change the oil separating filter, Chapter 23

19.2 TROUBLE-SHOOTING AND EMERGENCY REMEDIES FOR DRYER



ALL WORK MUST BE CARRIED OUT BY PROFESSIONALLY SKILLED PERSONNEL. BEFORE CARRYNG OUT ANY MAINTENANCE JOBS IT IS OBLIGATORY TO STOP THE MACHINE AND DISCONNECT IT FROM THE POWER MAINS.

N.B. OPERATIONS MARKED ■ ■ MUST BE CARRIED OUT BY PROFESSIONALLY SKILLED PERSONNEL APPROVED THE MANUFACTURER

FAULT FOUND	POSSIBLE CAUSES	OBSERVATIONS
1) No compressed air passes through the dryer outlet	1A) The pipes are frozen inside	<ul style="list-style-type: none"> ■ ■ -The bypass valve of the hot gas is broken or out-of-calibration -The room temperature is too low and the evaporators piping are obstructed with ice
2) Presence of condensate in the pipings.	2A) The condensate separator does not work correctly 2B) The dryer is working outside its rating 2C) The dryer is working under bad conditions of condensation	<ul style="list-style-type: none"> ■ ■ -Check the solenoid exhaust valve ■ ■ -Check the drainage timer -Check the flow rate of treated air -Check the room temperature -Check the air temperature at the drier inlet. -Clean the condenser. ■ ■ -Check the good operation of the fan.
3) The compressor head is very hot (> 55 °C)	Make reference to 2B Make reference to 2C 3A) The cooling circuit is not working with the right gas charge	<ul style="list-style-type: none"> ■ ■ -Check if there are leaks of refrigerating gas. ■ ■ - Charge it again.
4) Motor cuts out on overload	Make reference to 2B Make reference to 2C Make reference to 3A	
5) The motor hums and does not start.	The line voltage is too low. You switched the machine off and on again without leaving enough time for the pressure balancing. The starting system of the motor is defective.	<ul style="list-style-type: none"> -Contact the electric power company -Wait a few minutes before starting the machine again. ■ ■ -Check the running and starting relays and condensers (if any)
6) The compressor is very noisy.	Troubles with the internal mechanical parts or with the valves	

PART "B"



THIS PART "B" OF THE INSTRUCTIONS MANUAL IS RESERVED FOR PROFESSIONALLY SKILLED PERSONNEL APPROVED THE MANUFACTURER.

20.0 STARTING UP



BEFORE CARRYING OUT ANY OPERATION ON THE MACHINE, ENSURE THAT THE ELECTRIC POWER SUPPLY HAS BEEN DISCONNECTED.

20.1 PREPARING FOR SETTING UP

After checking everything as indicated in Chap. 12, follow the instructions in Fig. 22.

- Fit the sound-deadening panels Ref. 1
- These parts are packed in the bodywork.

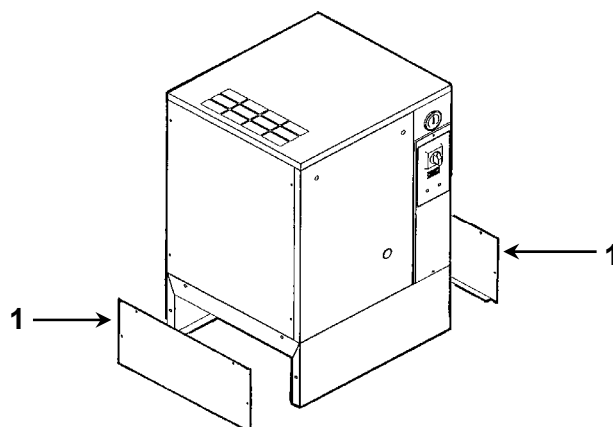

FIG. 22

20.2 PRELIMINARY CHECKS

Check the oil level Ref. 1 Fig. 23; when delivered the machine is filled with oil; if the oil level is not as intended, top up with the same oil as the original type.

If more than 3 months have passed between the inspection in the factory and the date of installation, lubricate the screw group before starting up, following the procedure described below:

- Remove the protection Ref. 2 Fig. 23
- Remove the fixed protection device (machine cover) Ref. 3 Fig. 23.
- Remove the cover Ref. 4 Fig. 23
- Remove the air filter Ref. 5 Fig. 23
- Pour a little oil into the suction unit.
- Reassemble the air filter Ref. 5 Fig. 23
- Reassemble the cover Ref. 4 Fig. 23

If more than 6 months have passed between the inspection in the factory and the date of installation, consult the manufacturer.

20.3 STARTING THE DRYER

Start the dryer before turning on the compressed air.

The compressed air piping will be free of condensate only by doing so.

The dryer must be kept running during all the time the air compressor is running. **WARNING:** if the dryer is switched off, before starting it again, wait at least 5 minutes in order to allow the pressure balancing.

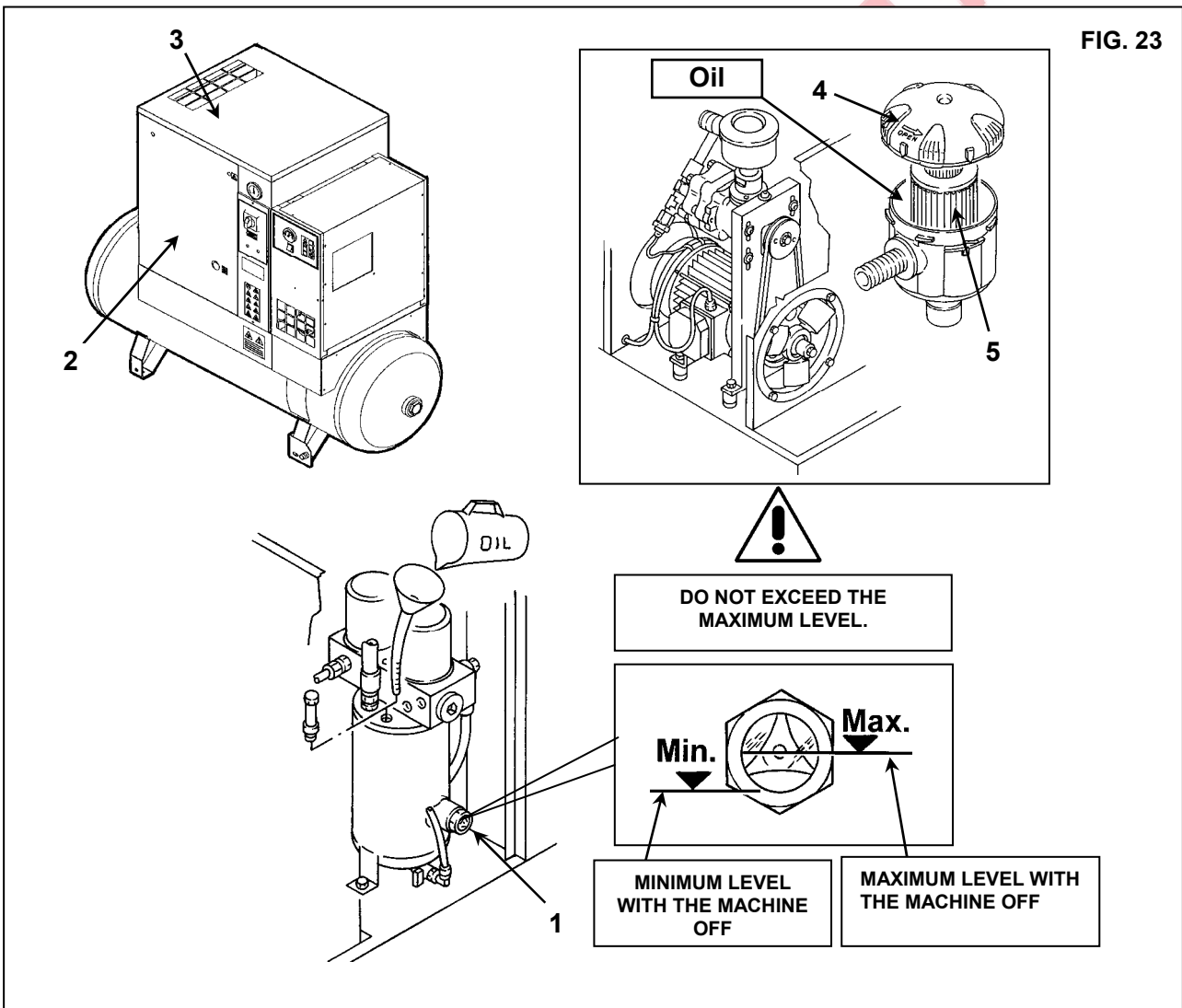

20.4 CHECK THE COMPRESSOR ROTATION DIRECTION AND START UP

- Check that all the protective shields are in place.
- Apply voltage to the control panel by operating the automatic differential switch of the line Ref. 1 Fig. 24.
- Start the compressor by turning the selector to "I", Ref. 2 Fig. 24 and after 1 second, stop it by turning the isolating switch to "OFF" Ref. 2a Fig. 24.

- If the rotation is correct, the paper sheet Ref. 3 is blown up (See Fig. A)
- If the rotation is not correct, the paper sheet remains flat (See Fig. B) **PHASE INCORRECT**



ALL WORK ON THE ELECTRIC PLANT, HOWEVER SLIGHT, MUST BE CARRIED OUT BY PROFESSIONALLY SKILLED PERSONNEL.

- Disconnect the energy supply and invert two connections as per Ref. 1 Fig. B.

IT IS ADVISABLE NOT TO DO ANYTHING ON THE MACHINE PANEL.

IF ALL THE INSTRUCTIONS FOUND IN THIS MANUAL HAVE BEEN OBSERVED THE MACHINE CAN BE STARTED.

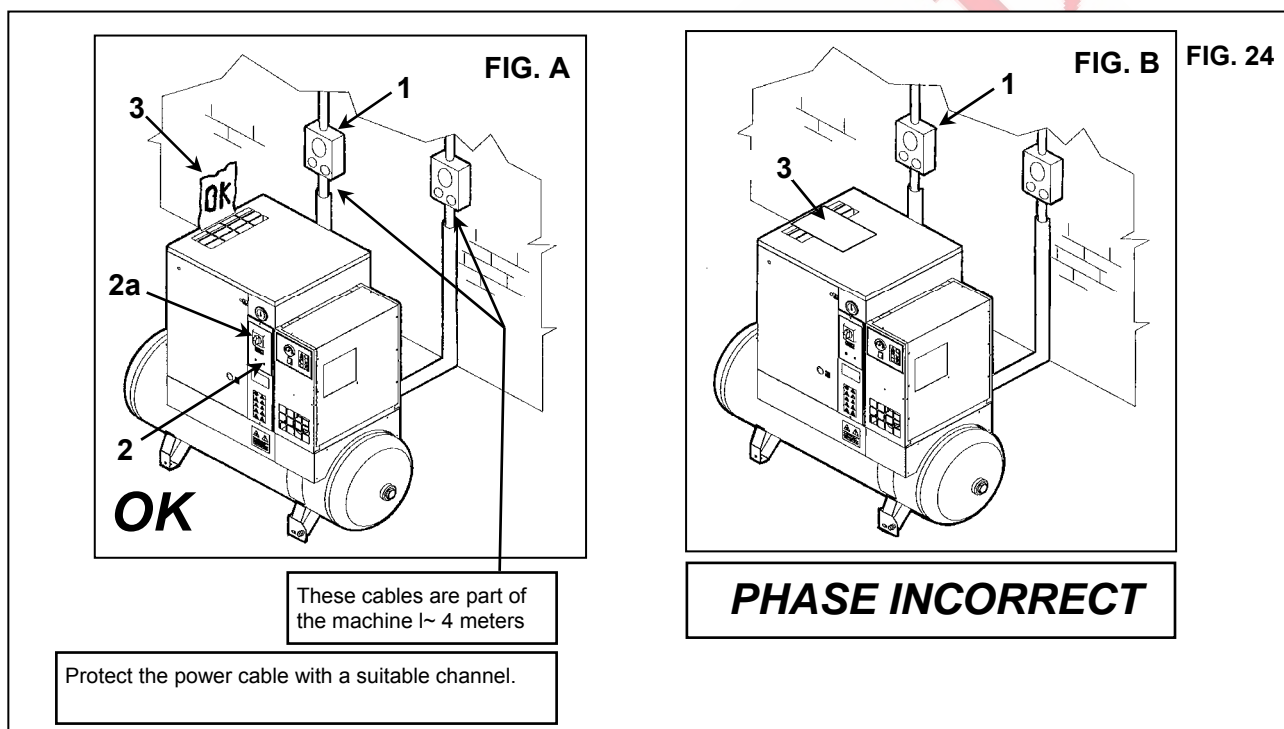

21.0 GENERAL ORDINARY MAINTENANCE REQUIRES TRAINED PERSONNEL



BEFORE CARRYING OUT ANY MAINTENANCE JOBS IT IS OBLIGATORY TO STOP THE MACHINE AND DISCONNECT IT FROM THE POWER MAINS.

MAINTENANCE SCHEDULE

These maintenance intervals are recommended for work environments that are not dusty and are well ventilated. For particularly dusty environments, double the frequency of controls.

Every Day (after use)	<ul style="list-style-type: none"> ■ Drain condensate from the air tank ■ Check automatic condensation emptying (dryer)
Every 50 working hours	<ul style="list-style-type: none"> ■ Drain condensate from the oil tank ■ Check the oil level
Every 500 hours	<ul style="list-style-type: none"> ■ Clean the air suction filter ■ Check automatic condensation emptying ■ Clean the condenser battery (on the dryer if fitted) ■ Clean the dirt collection filter ■ Check belt tension
Every 2000 hours	<ul style="list-style-type: none"> ■ Change the suction filter ■ Change the oil (*) ■ Change the oil filter
Every 4000 hours	<ul style="list-style-type: none"> ■ Clean the finned surface of the air-oil cooler ■ Change the oil separating filter

* It is recommended that the compressor oil be changed once per year regardless of the number of hours of operation. Oil must be changed more frequently than once per year if the compressor is operating in a dirty environment.

N.B.: THE OPERATIONS MARKED ■ ARE DESCRIBED IN PART "A" OF THIS MANUAL ON CHAPTER 15.1

COMPRESSED AIR ADVISORS

22.0 CHANGING THE OIL

CAUTION: THIS OPERATION MUST BE DONE TOGETHER WITH THE OIL FILTER AND AIR FILTER EXCHANGE



BEFORE CARRYING OUT ANY MAINTENANCE JOBS IT IS OBLIGATORY TO STOP THE MACHINE AND DISCONNECT IT FROM THE POWER MAINS AND FROM THE COMPRESSED AIR DISTRIBUTION NETWORK.

Oil changing is an important operation for the compressor:

if the lubrication of the bearings is not efficient, the compressor life will be short.

The oil must be changed when the machine is still warm, that is immediately after stopping it.

The suggestions listed below should be scrupulously followed.

After draining the old oil out of the machine Ref. 1 Fig. 25.

- Fill the oil manifold Ref. 2 Fig. 25 up to the level mark
- Pour a drop of oil into the intake unit, as described in CHAP. 20.1
- Close all the protections (cover and front protection)
- Start the compressor, (See pag. 17).
- After about 1 minute, stop the machine, (See pag. 17).

PROCEED AS DESCRIBED AT CHAPTER 15.3

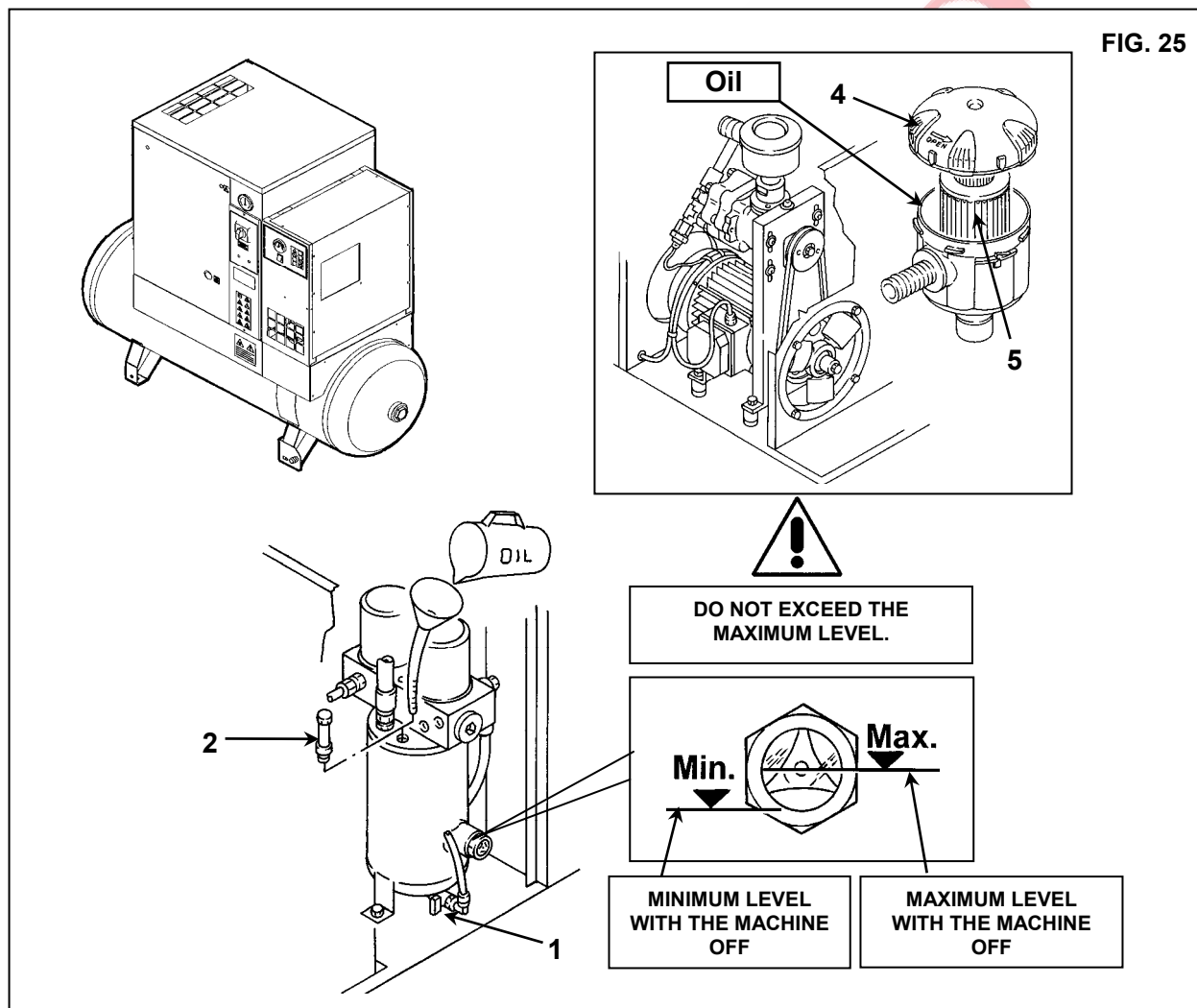

THE OLD OIL MUST BE DISPOSED OF IN COMPLIANCE WITH THE REGULATIONS IN FORCE.



DO NOT MIX DIFFERENT OILS FROM DIFFERENT MANUFACTURERS AND DIFFERENT VISCOSITIES (GRADES)

NOTE ON LUBRICANTS

When delivered the machine is filled with oil.

In normal conditions of use, these lubricants have proved to be able to withstand use for as many as 4.000 hours. However, due to the external polluting agents that get into the compressor with the air that it takes in, it is advisable to change the oil at more frequent intervals, as indicated on the routine maintenance chart.

If the compressor is being used at high temperatures (continuous operation above 90 °C - 194 °F) or in particularly severe conditions, we advise changing the oil at shorter intervals than those recommended in the maintenance chart.

OIL SPECIFICATIONS:

Mineral oil

Although Rotair is strongly recommended, mineral oil can be used after taking following precautions:

- The previously used oil should first be drained and the system flushed
- The oil filter and oil separator should be replaced
- The oil must meet the requirements as specified below

Properties: high-quality, mineral oil with oxidation inhibitors and anti-foam and anti-wear properties. The viscosity grade must correspond to the ambient temperature and ISO 3448, as follows:

Ambient temperature	Viscosity grade	Viscosity index
Consistently above 25 degrees Celsius	ISO VG 68	Minimum 95
Between 25 and 0 degrees Celsius	ISO VG 46	Minimum 95

We recommend GAOK cleaner when switching to a mineral oil. (5-gal pail part #1310250946)

23.0 REPLACE THE OIL SEPARATOR FILTER AND THE OIL FILTER



BEFORE CARRYING OUT ANY MAINTENANCE THE MACHINE MUST BE STOPPED, CUT OFF THE MACHINE FROM THE ELECTRICAL MAINS AND FROM THE COMPRESSED AIR DISTRIBUTION CIRCUIT, CHECK THAT THE MACHINE IS NOT UNDER PRESSURE.

N.B. INTERNAL PRESSURE IS AUTOMATICALLY DISCHARGED AFTER ABOUT 30 SECONDS WHEN THE MACHINE IS TURNED OFF

Proceed as follows:

- Open the front panel Ref. 1 Fig. 26 with the special key.
- Remove the fixed protection device (machine cover) Ref. 2 Fig. 26.
- Remove the oil separation filter Ref. 3 and oil filter Ref. 4 Fig. 26
- Lubricate the filter seals with a little oil before fitting.
- Tightening must be done by hand.
- Close the fixed protection (machine cover) Ref. 2 Fig. 26 device again, using the appropriate safety screws.
- Close the panel Ref. 1 Fig. 26.

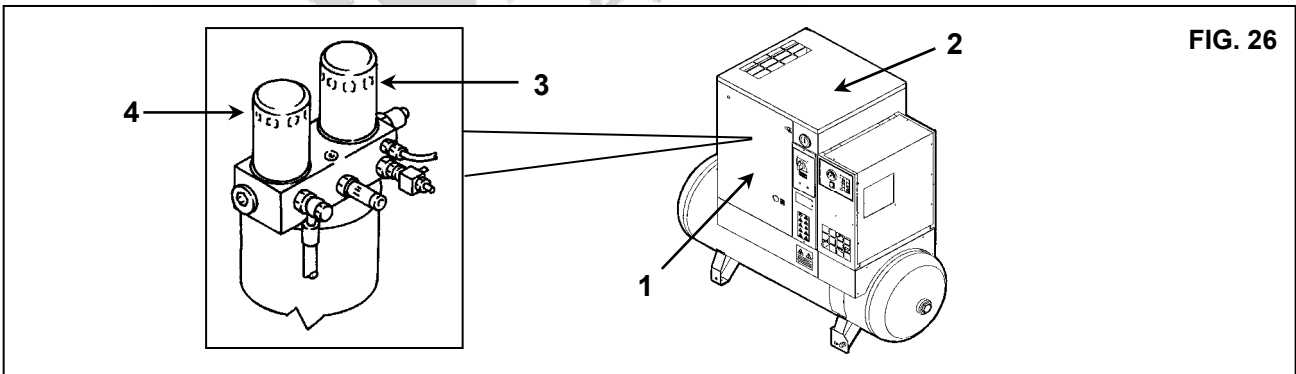

FIG. 26

24.0 BELT TENSION (Hp 3-4-5,5-7,5 / kW 2,2-3-4-5,5) Fig. 27

BEFORE CARRYING OUT ANY MAINTENANCE THE MACHINE MUST BE STOPPED, CUT OFF THE MACHINE FROM THE ELECTRICAL MAINS AND FROM THE COMPRESSED AIR DISTRIBUTION CIRCUIT, CHECK THAT THE MACHINE IS NOT UNDER PRESSURE.

Tightening or retightening new belts

Proceed as follows:

- Open the front panel Ref. 1 Fig. 27 with the special key.
- Remove the fixed protections device Ref. 2, 3, 4 Fig. 27.
- Slacken the screws by half a turn Ref. 5 Fig. 27
- Adjust the belt tension by turning the screw Ref. 6 Fig. 27, with an allen wrench.
- Close the screws again Ref. 5 (***) Fig. 27
- Tension is correct if, when a force of **5 kg**. Is exercised halfway along the belt between the pulleys, there is an offset of about **6 mm**. (see Fig. A).
- Close the fixed protections Ref. 2, 3, 4 Fig. 27 device again, using the appropriate safety screws
- Close the panel Ref. 1 Fig. 27.

24.1 BELT TENSION (Hp 10 / kW 7,5) Fig. 28-29

BEFORE CARRYING OUT ANY MAINTENANCE THE MACHINE MUST BE STOPPED, CUT OFF THE MACHINE FROM THE ELECTRICAL MAINS AND FROM THE COMPRESSED AIR DISTRIBUTION CIRCUIT, CHECK THAT THE MACHINE IS NOT UNDER PRESSURE.

Tightening or retightening new belts

Proceed as follows:

- Open the front panel Ref. 1 Fig. 28 with the special key.
- Remove the fixed protections device Ref. 2, 3, 4 Fig. 28.
- Slacken the screws by half a turn Ref. 5 Fig. 28
- Adjust the belt tension by turning the screw Ref. 6 Fig. 28, with an allen wrench.
- Close the screws again Ref. 5 (***) Fig. 28
- Tension is correct if, when a force of **5 kg**. Is exercised halfway along the belt between the pulleys, there is an offset of about **6 mm**. (see Fig. A).
- Close the fixed protections Ref. 2, 3, 4 Fig. 28 device again, using the appropriate safety screws
- Close the panel Ref. 1 Fig. 28.

25.0 REPLACING THE BELT (Hp 3-4-5,5-7,5 / kW 2,2-3-4-5,5) Fig. 27



BEFORE CARRYING OUT ANY MAINTENANCE THE MACHINE MUST BE STOPPED, CUT OFF THE MACHINE FROM THE ELECTRICAL MAINS AND FROM THE COMPRESSED AIR DISTRIBUTION CIRCUIT, CHECK THAT THE MACHINE IS NOT UNDER PRESSURE.

Proceed as follows:

- Open the front panel Ref. 1 Fig. 27 with the special key.
- Remove the fixed protections device Ref. 2, 3, 4 Fig. 27.
- Slacken the screws by half a turn Ref. 5 Fig. 27
- Release belt tension by unscrewing the screw Ref. 6 Fig. 27
- Unscrew screws Ref. 7 Fig. 27, remove the ferrule Ref. 8
- Dismantle and remove the belt Ref. 9 from the fan opening, and fit the new belt following the instructions in reverse order.
- **To set belt tension, proceed as given in Chap. 24.0**
- Reassemble the virola Ref. 8 Fig. 27
- Reassemble the permanent protections Ref. 2, 3 Fig. 27 fixing them in place with the special safety screws
- Close the panel Ref. 1 Fig. 27

25.1 REPLACING THE BELT (Hp 10 / kW 7,5) Fig. 28-29



BEFORE CARRYING OUT ANY MAINTENANCE THE MACHINE MUST BE STOPPED, CUT OFF THE MACHINE FROM THE ELECTRICAL MAINS AND FROM THE COMPRESSED AIR DISTRIBUTION CIRCUIT, CHECK THAT THE MACHINE IS NOT UNDER PRESSURE.

Proceed as follows:

- Open the front panel Ref. 1 Fig. 28 with the special key.
- Remove the fixed protections device Ref. 2, 3, 4 Fig. 28.
- Slacken the screws by half a turn Ref. 1 Fig. 29
- Release belt tension by unscrewing the screw Ref. 2 Fig. 29
- Unscrew screws Ref. 3 Fig. 29, remove the ferrule Ref. 4
- Dismantle and remove the belt Ref. 5 (Q.ty 2 from the fan opening, and fit the new belt following the instructions in reverse order.
- **To set belt tension, proceed as given in Chap. 24.0**
- Reassemble the virola Ref. 4 Fig. 29
- Reassemble the permanent protections Ref. 2, 3 Fig. 28 fixing them in place with the special safety screws
- Close the panel Ref. 1 Fig. 28

Hp 3-4-5,5-7,5 / kW 2,2-3-4-5,5

FIG. 27

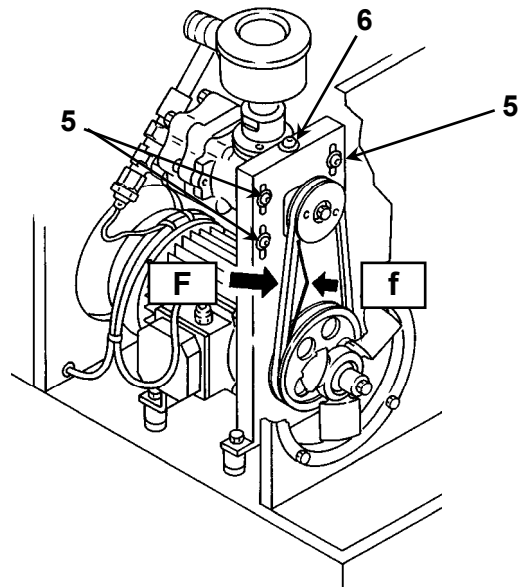
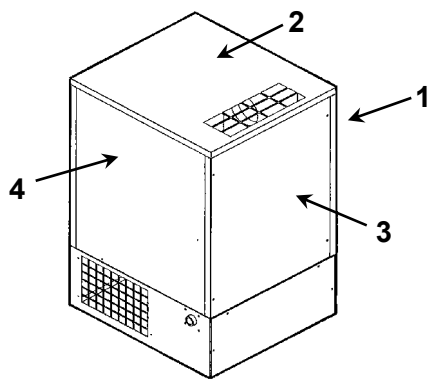
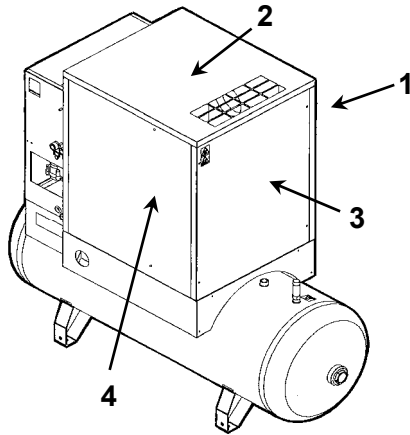

(**) Tightening torque = N. 25

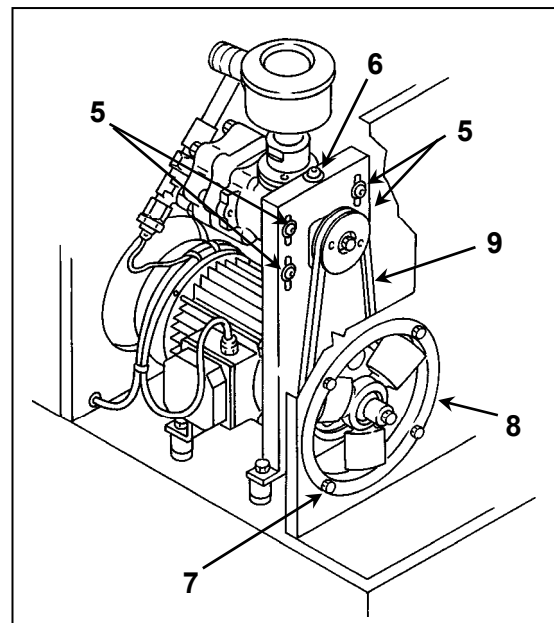
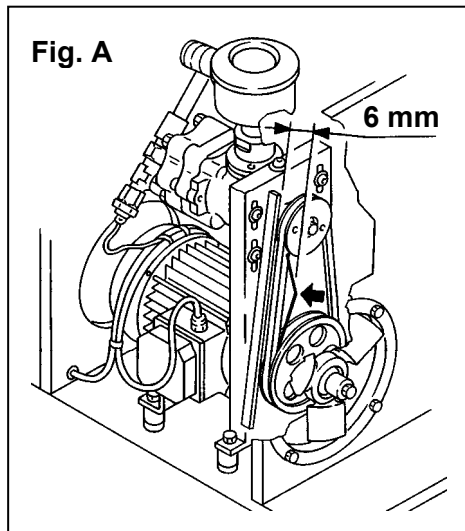

1 - F = 5 kg., force to be applied at the centre line, at right angles to the new belt.
 2 - f = 6 mm., clearance after the application of F. (after 100 h operation F = 3 kg.)

Hp 10 / kW 7,5

FIG. 28

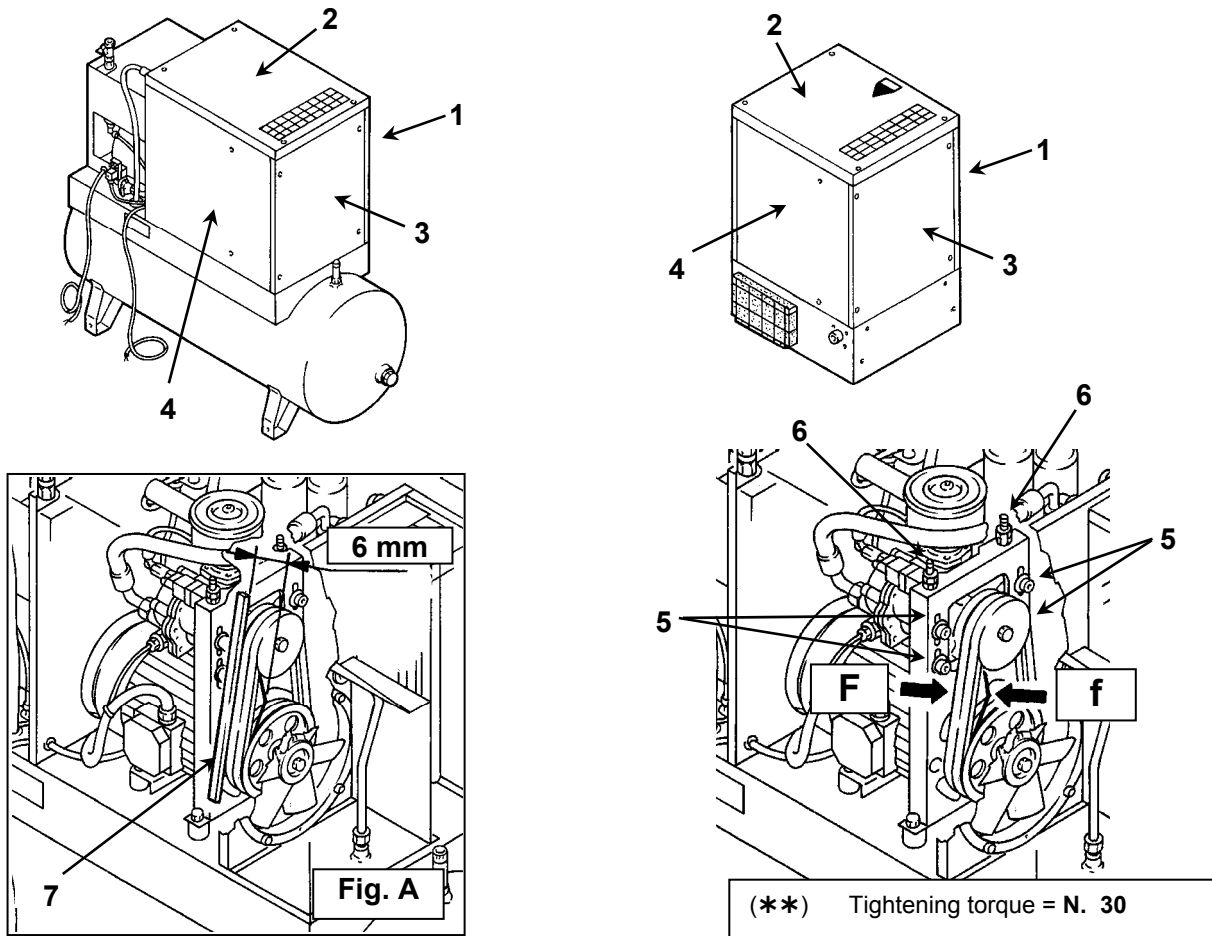
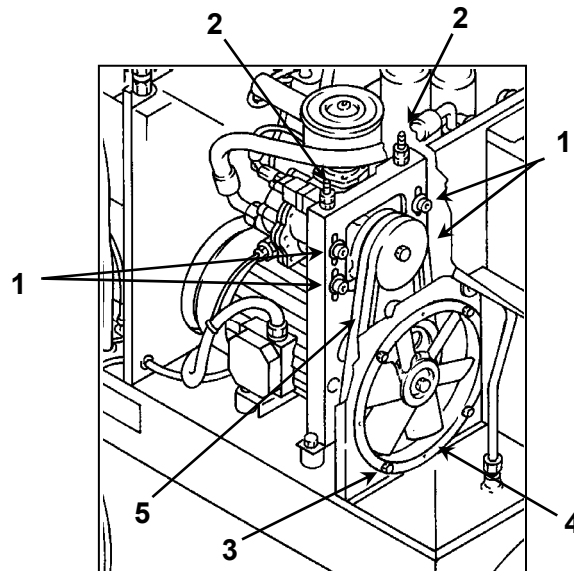
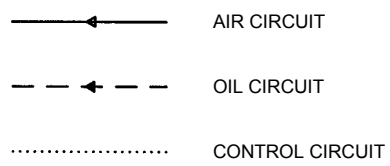
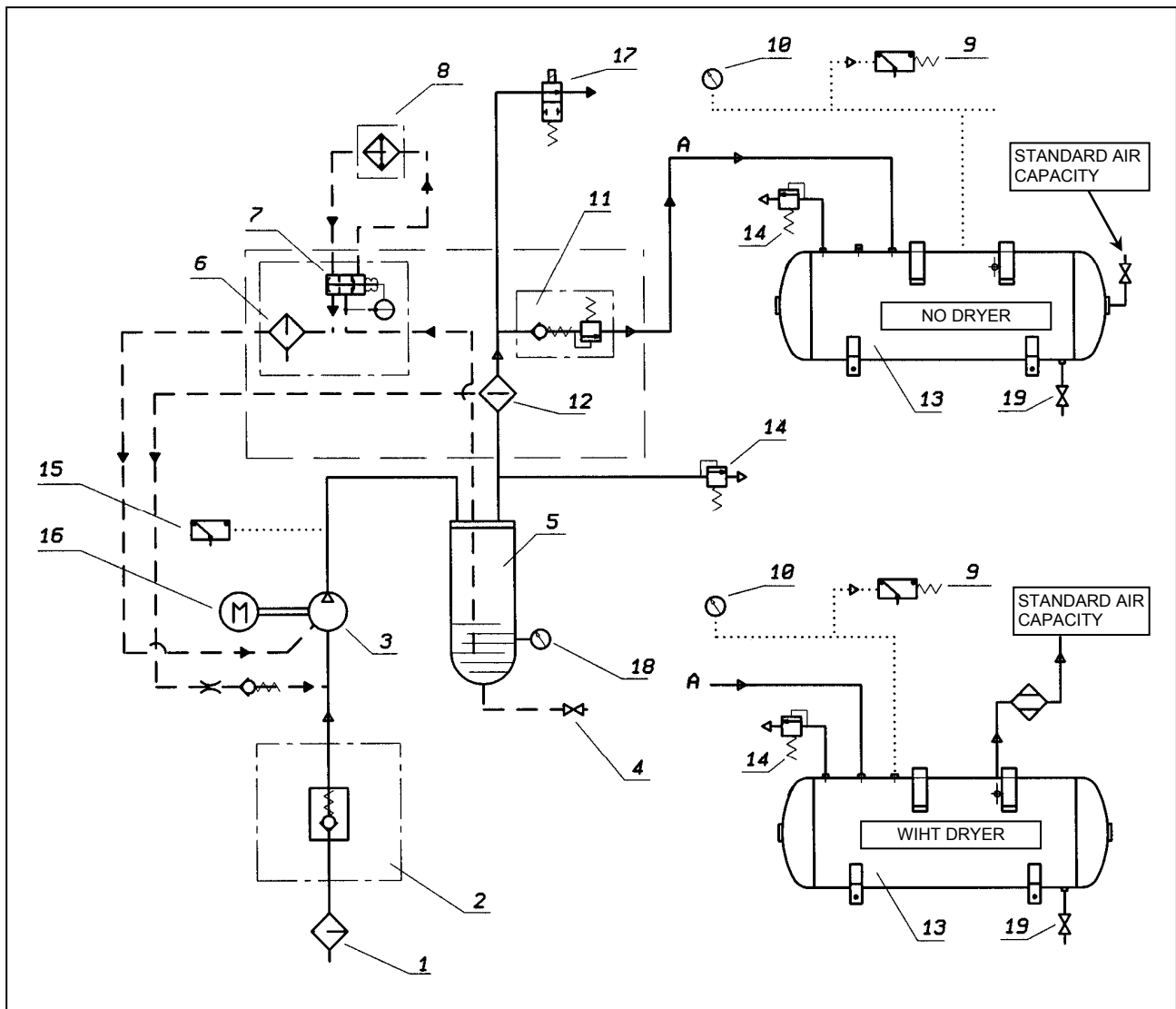

FIG. 29



1 - F = 5 kg., force to be applied at the centre line, at right angles to the new belt.
 2 - f = 6 mm., clearance after the application of F. (after 100 h operation F = 3 kg.)

26.0 OLEOPNEUMATIC DIAGRAM (Hp 3-4-5,5-7,5 / kW 2,2-3-4-5,5)



- | | |
|-----------------------|---------------------------|
| 1 SUCTION FILTER | 11 MINIMUM PRESSURE VALVE |
| 2 SUCTION REGULATOR | 12 AIR-OIL SEPARATOR |
| 3 SCREW COMPRESSOR | 13 AIR RECEIVER |
| 4 OIL DISCHARGE VALVE | 14 SAFETY VALVE |
| 5 OIL MANIFOLD | 15 SAFETY OIL TEMPERATURE |
| 6 OIL FILTER | 16 ELECTRIC MOTOR |
| 7 THERMOSTATIC VALVE | 17 SOLENOID VALVE |
| 8 AIR-OIL COOLER | 18 OIL LEVEL |
| 9 AIR PRESSURE SWITCH | |
| 10 AIR PRESSURE GAUGE | |

26.1 OLEOPNEUMATIC DIAGRAM (Hp 10 / kW 7,5)

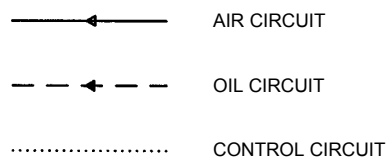
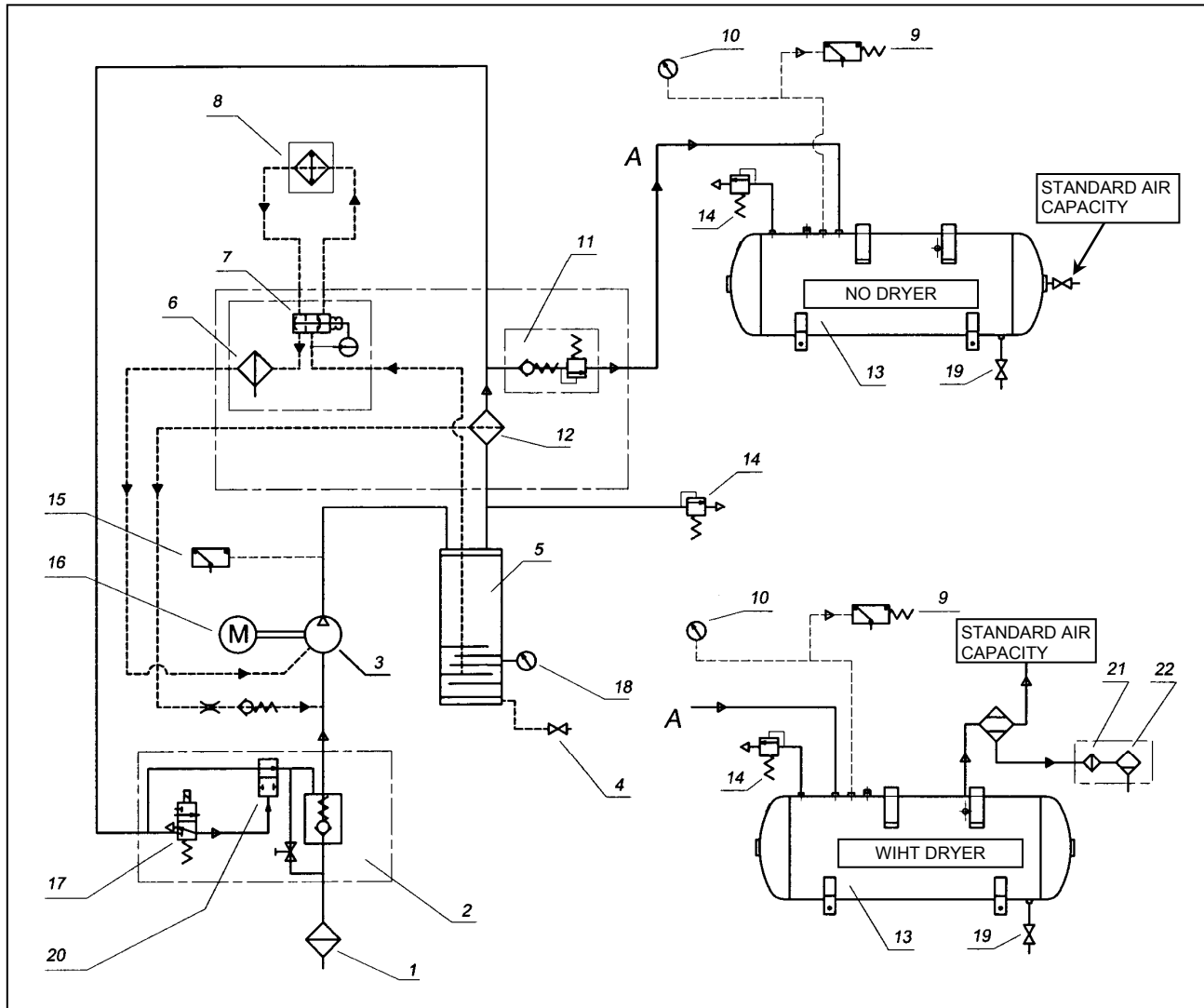

- | | |
|---------------------------|--|
| 1 SUCTION FILTER | 13 AIR RECEIVER |
| 2 SUCTION REGULATOR | 14 SAFETY VALVE |
| 3 SCREW COMPRESSOR | 15 SAFETY OIL TEMPERATURE |
| 4 OIL DISCHARGE VALVE | 16 ELECTRIC MOTOR |
| 5 OIL MANIFOLD | 17 NO-LOAD RUNNING SOLENOID VALVE |
| 6 OIL FILTER | 18 OIL LEVEL |
| 7 THERMOSTATIC VALVE | 19 CONDENSATE DISCHARGE VALVE |
| 8 AIR-OIL COOLER | 20 BLED SOLENOID VALVE |
| 9 AIR PRESSURE SWITCH | 21 IMPURITY TRAP |
| 10 AIR PRESSURE GAUGE | 22 CONDENSATE DISCHARGE SOLENOID VALVE |
| 11 MINIMUM PRESSURE VALVE | |
| 12 AIR-OIL SEPARATOR | |

27.0 PRESSURE SWITCH ADJUSTMENT

Note: Adjustments can only be made when the pressure switch is pressurized.

The QRS compressor uses a Condor MDR1/11 pressure switch to control the starting and stopping of the compressor. The stopping pressure is adjusted by rotating the adjustment screw clockwise to raise the pressure set point and counter-clockwise to lower the set point. The adjustment screw is accessible by removing the pressure switch cover.

The pressure differential between stopping and starting is a fixed setting at 2 bar (approx. 30 psi)

28.0 CALIBRACION FOR DRYER

BYPASS VALVE FOR HOT GAS

N.B. These valves have already been calibrated and they do not require any adjustment. A dew point different from the rated one generally depends on causes which are not attributable to their operation.

- 1) Closing cap
- 2) Adjusting screw

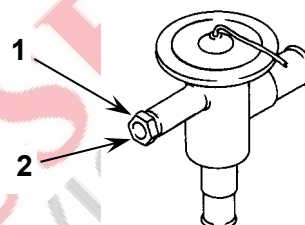

WORKING PRESSURES AND TEMPERATURES OF R134a

SUCTION SIDE OF REFRIGERATION COMPRESSOR		
	Evaporat. Temperat. °C	Evaporating Pressure bar
RATED VALUES (Temperat. 20 °C)	1 ÷ 2	R134A 2,1 ÷ 2,3

28.1 FLOW DIAGRAM OF THE DRYER

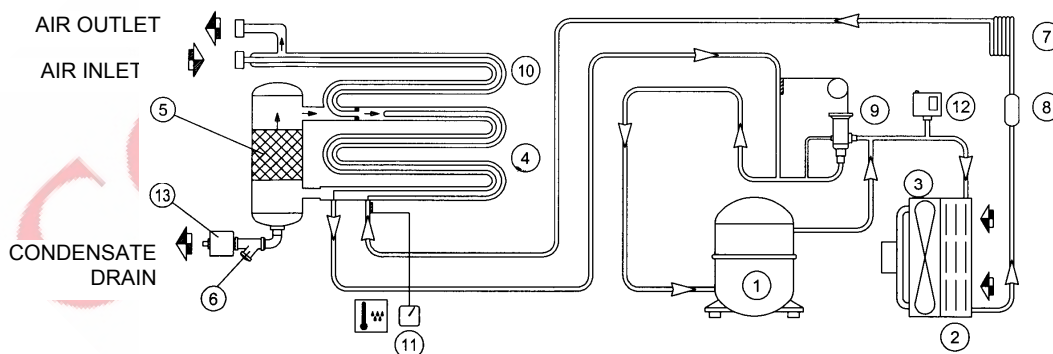

- 1 REFRIGERANT COMPRESSOR
- 2 FREON CONDENSER
- 3 MOTOR FAN
- 4 EVAPORATOR
- 5 DEMISTER CONDENSATE SEPARATOR
- 6 IMPURITY TRAP
- 7 EXPANSION CAPILLARY TUBE
- 8 REFRIGERATION FLUID FILTER
- 9 HOT GAS BYPASS VALVE
- 10 AIR-TO-AIR EXCANGER
- 11 DEW POINT THERMOMETER
- 12 FAN PRESSURE SWITCH
- 13 CONDENSATE DISCHARGE SOLENOID VALVE

29.0 VOLTAGE CONVERSION

IMPORTANT: Be sure to remove electrical power to the unit before performing this voltage conversion.

The standard voltage configuration for the QRS compressor is mentioned on the data plate of the machine. To convert the operating voltage of the compressor for 200V or 230V or 460V operation, the following simple modifications must be performed. Access to all components can be obtained by loosening the two screws on the front of the control cubicle and removing the faceplate.

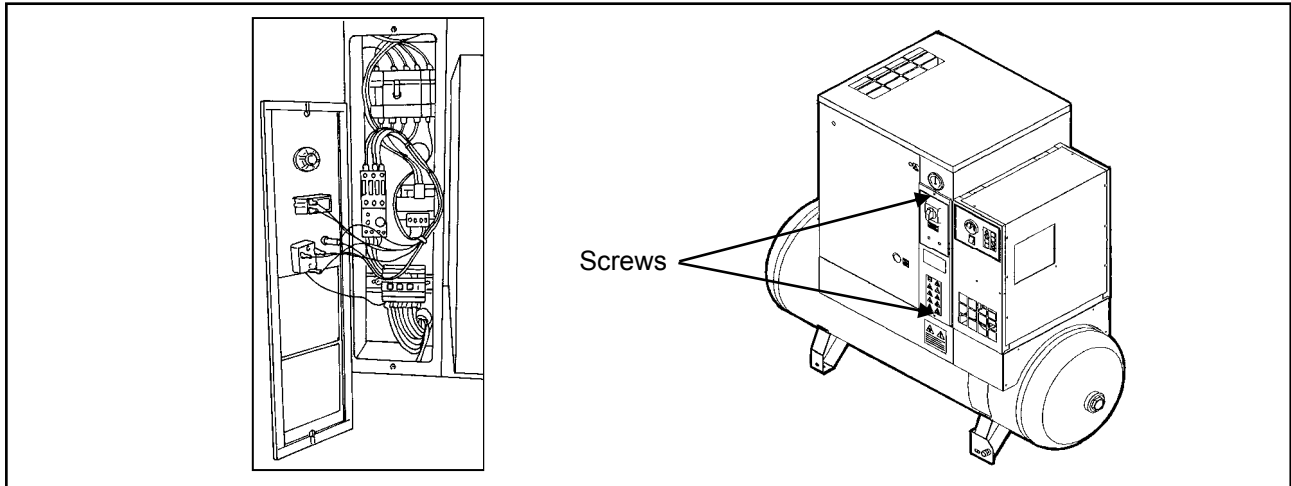

Required Modifications:

1. Adjust the motor overload (OL) setting.
2. Rewire the control power transformer (T).
3. Replace the control power fuses (FU1) with the KTK-1/2 fuses provided in case of 460V.
4. Modify the terminal bridge configuration for the desired voltage.
5. Replace the "VOLTAGE" sticker with the appropriate voltage sticker provided.

To adjust the motor overload (OL) setting, simply rotate the adjustment screw on the face of the overload to the required setting (see table below).

Overload (OL) Settings				
	HP 3 kW 2,2	HP 5 kW 3,7	HP 7,5 kW 5,5	HP 10 kW 7,5
200-208V	14A	21,2A	24,7A	36,3A
230V	11,8A	18,2A	22,5A	34,4A
460V	6A	9,1A	11,4A	16,9A

To rewire the control power transformer (T), remove the wire connected to the transformer terminal marked "460" and move the wire to the terminal marked with the desired voltage (200V or 230V).

Transformer T	Transformer T	Transformer T

The two fuses marked FU1 are easily replaced by opening the fuseholder and replacing the fuses with the KTK-1 fuses supplied with the compressor.

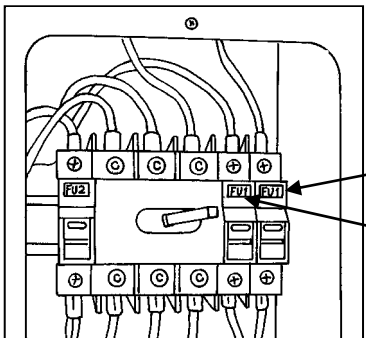

VOLTAGE V ac	208	230	460	
Fuses Fusibles	V (AC/DC)	Class	Class	Class
FU1	600 Vac	KTK-1	KTK-1	KTK-1/2
FU1	600 Vac	KTK-1	KTK-1	KTK-1/2
FU2	600 Vac	KTK-3	KTK-3	KTK-3

**FUSE MARKINGS
INSCRIPTIONS FUSIBLE**

To modify the terminal bridge configuration to the motor, configure the terminal bridges for the desired voltage (200V or 460V or 230V) according to the schematic below. The terminal bridges can be easily removed using a pair of pliers. Additional terminal bridges are provided with the compressor.

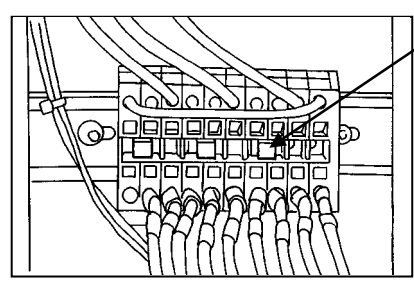

460V

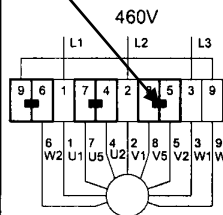

Bridge / Pont
9-6, 7-4, 8-5.

200-208V

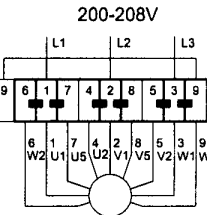

Bridge / Pont
6-1-7, 4-2-8, 5-3-9.

230V

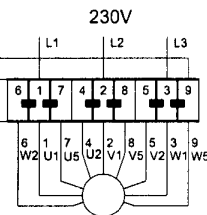

Bridge / Pont
6-1-7, 4-2-8, 5-3-9.

Finally, locate the yellow voltage stickers provided with the compressor. Replace the "460V" sticker with the appropriate voltage sticker (200V or 230V).

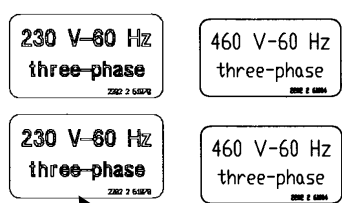

Fuses KTK-1 / KTK 1/2

230 V-60 Hz
three-phase
230V 2 60Hz

460 V-60 Hz
three-phase
460V 2 60Hz

230 V-60 Hz
three-phase
230V 2 60Hz

460 V-60 Hz
three-phase
460V 2 60Hz

Voltage Stickers

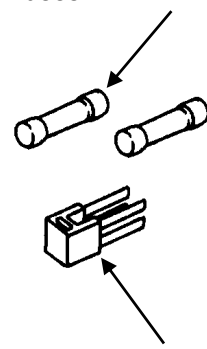

Terminal Bridges

200-208 V
60 Hz
three-phase
230V 2 60Hz

200-208 V
60 Hz
three-phase
230V 2 60Hz

Voltage Stickers

Your compressor is now configured for 230V, 3-phase operation.

COMPRESSED
AIR ADVISORS
Inc.

Compressed Air Advisors, Inc.

Phone: 877.247.2381

info@compressedairadvisors.com

www.compressedairadvisors.com