



13-25-632  
Version: 00  
September 8, 2018

**L-SERIES  
SINGLE STAGE  
BASE- MOUNTED and TANK MOUNTED  
COMPRESSORS**

**GD PILOT Controller**

**MODELS CL15-22C (Fixed Speed)  
MODELS CLRS15-22C (Variable Speed)**

**20 / 25 / 30 HP**

**50 / 60 HZ**

**OPERATING AND  
SERVICE MANUAL**

## **MAINTAIN COMPRESSOR RELIABILITY AND PERFORMANCE WITH GENUINE CHAMPION® COMPRESSOR PARTS AND SUPPORT SERVICES**

Champion® Compressor genuine parts, manufactured to design tolerances, are developed for optimum dependability . specifically for Champion compressor systems. Design and material innovations are the result of years of experience with hundreds of different compressor applications. Reliability in materials and quality assurance is incorporated in our genuine replacement parts.

Your authorized Champion Compressor distributor offers all the backup you need. A network of authorized distributors provides the finest product support in the air compressor industry.

Your authorized distributor can support your Champion air compressor with these services:

1. Trained parts specialists to assist you in selecting the correct replacement parts.
2. Factory warranted new and remanufactured rotary screw airends. Most popular model remanufactured airends are maintained in stock at the factory, for purchase on an exchange basis with liberal core credit available for the replacement unit.
3. A full line of factory tested RotorLubi™ compressor lubricants specifically formulated for use in Champion compressors.
4. Repair and maintenance kits designed with the necessary parts to simplify servicing your compressor.

Authorized distributor service technicians are factory trained and skilled in compressor maintenance and repair. They are ready to respond and assist you by providing fast, expert maintenance and repair services.

**To Contact Champion or locate your local distributor:  
Visit: [www.championpneumatic.com/contactus.aspx](http://www.championpneumatic.com/contactus.aspx)**

Or

Call: (800) 232-0865

### **INSTRUCTIONS FOR ORDERING REPAIR PARTS**

When ordering parts, specify Compressor MODEL, Method of Cooling, HORSEPOWER and SERIAL NUMBER (see nameplate on unit). The Airend Serial Number is also stamped on top of the discharge bearing carrier casting.

All orders for Parts should be placed with the nearest authorized distributor.

Where NOT specified, quantity of parts required per compressor or unit is one (1); where more than one is required per unit, quantity is indicated in parenthesis. **SPECIFY EXACTLY THE NUMBER OF PARTS REQUIRED.**

**DO NOT ORDER BY SETS OR GROUPS.**

To determine the Right-Hand and Left-Hand side of a compressor, stand at the motor end and look toward the compressor. Right-Hand and Left- Hand are indicated in parenthesis following the part name, i.e. (RH) and (LH), when appropriate.

## WARNING – PROHIBITION – MANDATORY LABEL INFORMATION

Champion Rotary Screw compressors are the result of advanced engineering and skilled manufacturing. To be assured of receiving maximum service from this machine, the owner must exercise care in its operation and maintenance. This book is written to give the operator and maintenance department essential information for day-to-day operation, maintenance and adjustment. Careful adherence to these instructions will result in economical operation and minimum downtime.

**Boxed text formats are used, within this manual, to alert users of the following conditions:**

**Safety Labels are used, within this manual and affixed to the appropriate areas of the compressor package, to alert users of the following conditions:**



Indicates a hazard with a high level of risk, which if not avoided, WILL result in death or serious injury.



Equipment Starts Automatically



Health Hazard . Explosive Release of Pressure



Cutting of Finger or Hand Hazard . Rotating Impeller Blade



High Voltage . Hazard of Shock, Burn, or Death Present until Electrical Power is Removed



Cutting of Finger or Hand Hazard . Rotating Fan Blade



Entanglement of Fingers or Hand/Rotating Shaft



Indicates a hazard with a medium level of risk which, if not avoided, **COULD** result in death or serious injury.



Asphyxiation Hazard . Poisonous Fumes or Toxic Gases in Compressed Air



Indicates a hazard with a low level of risk which, if not avoided, **MAY** result in a minor or moderate injury.



Burn Hazard . Hot surface

## PROHIBITION/MANDATORY ACTION REQUIREMENTS



Do not Operate Compressor with Guard Removed



Lockout Electrical Equipment in De-Energized State



Do Not Lift Equipment with Hook . No Lift Point



Loud Noise Hazard . Wear Ear Protection



Handle Package at Forklift Points Only



Read the Operator's Manual Before Proceeding with Task

## SAFETY PRECAUTIONS

Safety is everybody's business and is based on your use of good common sense. All situations or circumstances cannot always be predicted and covered by established rules. Therefore, use your past experience, watch out for safety hazards and be cautious. Some general safety precautions are given below:



Failure to observe these notices will result in injury to or death of personnel.

- Keep fingers and clothing away from rotating fan, drive coupling, etc.
- Disconnect the compressor unit from its power source, lockout and tagout before working on the unit – this machine is automatically controlled and may start at any time.
- Do not loosen or remove the oil filler plug, drain plugs, covers, the thermostatic mixing valve or break any connections, etc., in the compressor air or oil system until the unit is shut down and the air pressure has been relieved.
- Electrical shock can and may be fatal.
- Perform all wiring in accordance with the National Electrical Code (NFPA-70) and any applicable local electrical codes. Wiring and electrical service must be performed only by qualified electricians.

Open main disconnect switch, lockout and tagout and check for voltage before working on the control.



Failure to observe these notices could result in damage to equipment.

- Stop the unit if any repairs or adjustments on or around the compressor are required.
- Do not use the air discharge from this unit for breathing – not suitable for human consumption.
- An Excess Flow Valve should be on all compressed air supply hoses exceeding 1/2 inch inside diameter (OSHA Regulation, Section 1926.302).
- Do not exceed the rated maximum pressure values shown on the nameplate.
- Do not operate unit if safety devices are not operating properly. Check periodically. Never bypass safety devices.

## TABLE OF CONTENTS

Maintain Compressor Reliability And Performance With Genuine Gardner Denver Compressor Parts .....	1
Instructions For Ordering Repair Parts.....	1
Warning . Prohibition . Mandatory Label Information .....	2
Safety Precautions .....	4
Index .....	6
Section 1, General Information .....	8
Section 2, Installation.....	13
Section 3, Starting & Operating Procedures.....	19
Section 4, Controls & Instrumentation.....	24
Section 5, Lubrication. Oil Cooler, Oil Filter & Separator .....	56
Section 6, Heat Exchangers (Oil/Air).....	64
Section 7, Air Filters .....	67
Section 8, Belt Drive System.....	69
Section 9, Servicing Of Miscellaneous Devices.....	72
Section 10, Tank Mounted Compressor . Total System.....	82
Section 11, Maintenance Schedule.....	83
Section 12, Troubleshooting .....	85

### This book covers the following models:

HP	PSIG	Air Cooled	Parts List	Controller Manual
20 / 25 / 30	110 / 130 / 145 / 190	CL15-22C	13-25-552	13-25-519
20 / 25 / 30	110 / 130 / 145 / 190	CLRS15-22C	13-25-554	13-25-517

## INDEX

<p>Air Cooled Unit ..... 13</p> <p>Air Filters</p> <p style="padding-left: 20px;">Section 7.....67</p> <p>Air Flow in Compressor System ..... 8</p> <p>Air Receiver</p> <p style="padding-left: 20px;">Auxiliary ..... 16</p> <p><b>BELT DRIVE SYSTEM</b></p> <p style="padding-left: 20px;"><b>SECTION 8.....69</b></p> <p>Cold Weather</p> <p style="padding-left: 20px;">Installation ..... 16</p> <p>Compression Principle..... 8</p> <p>Compressor..... 8</p> <p>Controls &amp; Instrumentation</p> <p style="padding-left: 20px;">AirSmart G2 Controller Operation.....24</p> <p style="padding-left: 20px;">General Description .....24</p> <p style="padding-left: 20px;">Section 4.....24</p> <p>Cooling, Sealing and Lubrication..... 8</p> <p>Daily Check .....23</p> <p>Discharge Service Line ..... 16</p> <p><b>ELECTRICAL WIRING</b> ..... 17</p> <p><b>ELECTRICAL WIRING Sizing</b>.....17</p> <p>Enclosure ..... 15</p> <p>Foundation ..... 14</p> <p><b>GENERAL INFORMATION</b></p> <p style="padding-left: 20px;"><b>SECTION 1..... 8</b></p> <p>Grounding ..... 17</p> <p><b>HEAT EXCHANGERS (OIL/AIR)</b></p> <p style="padding-left: 20px;">Section 6.....64</p> <p>Inlet Line ..... 16</p> <p>Installation</p> <p style="padding-left: 20px;">Cold Weather..... 16</p> <p style="padding-left: 20px;">General..... 13</p> <p style="padding-left: 20px;">Section 2..... 13</p> <p>Lifting Unit..... 13</p> <p>Location ..... 13</p> <p>Lubrication, Cooling and Sealing..... 8</p> <p><b>LUBRICATION, OIL COOLER, OIL FILTER &amp; SEPARATOR</b></p> <p style="padding-left: 20px;"><b>SECTION 5.....56</b></p> <p><b>MAINTENANCE SCHEDULE</b></p> <p style="padding-left: 20px;"><b>SECTION 11.....83</b></p> <p>Miscellaneous Control Devices .....53</p> <p>Moisture Separator/Trap</p> <p style="padding-left: 20px;">Optional ..... 16</p>	<p>Motor Lubrication ..... 18</p> <p>Oil Reservoir</p> <p style="padding-left: 20px;">Drain ..... 14</p> <p>Piping</p> <p style="padding-left: 20px;">Control ..... 16</p> <p>Prestart-Up Instructions..... 19</p> <p style="padding-left: 20px;">Air Filter..... 19</p> <p style="padding-left: 20px;">Compressor Oil ..... 19</p> <p style="padding-left: 20px;">Electrical ..... 19</p> <p style="padding-left: 20px;">Enclosure ..... 22</p> <p style="padding-left: 20px;">Grounding ..... 19</p> <p style="padding-left: 20px;">Inlet Filter ..... 19</p> <p style="padding-left: 20px;">Operating Mode..... 22</p> <p style="padding-left: 20px;">Piping..... 19</p> <p style="padding-left: 20px;">Rotation..... 20</p> <p style="padding-left: 20px;">V-Belt System..... 20</p> <p><b>SAFETY PRECAUTIONS</b> ..... 4</p> <p>Sealing, Lubrication and Cleaning ..... 8</p> <p>Service Check List ..... 83</p> <p style="padding-left: 20px;">Every 1000 Hours Operation..... 83</p> <p style="padding-left: 20px;">Every 125 Hours Operation ..... 83</p> <p style="padding-left: 20px;">Every 4000 Hours Operation..... 83</p> <p style="padding-left: 20px;">Every 8 Hours Operation ..... 83</p> <p style="padding-left: 20px;">Every Year ..... 83</p> <p style="padding-left: 20px;">Motor Lubrication..... 83</p> <p><b>SERVICING OF MISCELLANEOUS DEVICES</b></p> <p style="padding-left: 20px;"><b>SECTION 9 ..... 72</b></p> <p><b>STARTING &amp; OPERATING PROCEDURES</b></p> <p style="padding-left: 20px;"><b>SECTION 3 ..... 19</b></p> <p>Starting the Unit ..... 23</p> <p style="padding-left: 20px;">Unit Cold ..... 23</p> <p>Stopping the Unit ..... 23</p> <p><b>TANK MOUNTED COMPRESSOR . TOTAL SYSTEM</b></p> <p style="padding-left: 20px;"><b>SECTION 10 ..... 82</b></p> <p><b>TROUBLE SHOOTING</b></p> <p style="padding-left: 20px;"><b>SECTION 11 ..... 85</b></p> <p style="padding-left: 20px;"><b>SECTION 12 ..... 85</b></p> <p><b>TROUBLESHOOTING VOLTAGE PROBLEMS</b> ..... 88</p> <p><b>WARNING . PROHIBITION . MANDATORY LABEL INFORMATION</b> ..... 2</p> <p>Wiring</p> <p style="padding-left: 20px;">Electrical ..... 17</p>
--	---

## LIST OF ILLUSTRATIONS

FIGURE 1- 1- COMPRESSOR CYCLE.....	8
FIGURE 1- 2. COMPRESSOR ILLUSTRATION . BASE MOUNT UNIT.....	9
FIGURE 1- 3. COMPRESSOR ILLUSTRATION - INTERNAL DETAILS.....	10
FIGURE 1- 4 . COMPRESSOR ILLUSTRATION . TOTAL SYSTEM.....	11
FIGURE 1- 5 . COMPRESSOR ILLUSTRATION . TOTAL SYSTEM.....	12
FIGURE 2- 1 . TYPICAL COMPRESSOR ROOM.....	14
FIGURE 2- 2 . AIR FLOW CHART.....	14
FIGURE 2- 3 . COLD WEATHER INSTALLATION - TYPICAL.....	15
FIGURE 2- 4 . Motor FLC.....	17
FIGURE 3- 1 . GD Pilot Controller Layout and Main Screen.....	21
FIGURE 4- 1 . GD Pilot Controller Layout and Main Screen.....	24
FIGURE 4- 2 . WIRING DIAGRAM, FIXED SPEED . 200-230v 50/60Hz.....	26
FIGURE 4- 3 . WIRING DIAGRAM, FIXED SPEED 380-400V 50/60Hz.....	29
FIGURE 4- 4 . WIRING DIAGRAM, FIXED SPEED . 460v 60Hz.....	32
FIGURE 4- 5 . WIRING DIAGRAM, FIXED SPEED . 575v 60Hz.....	36
FIGURE 4- 6 . WIRING DIAGRAM, FIXED SPEED . TRI-VOLTAGE. 200-230/460v 60Hz.....	38
FIGURE 4- 7 . WIRING DIAGRAM, VARIABLE SPEED . 230v-60Hz.....	41
FIGURE 4- 8 . WIRING DIAGRAM, VARIABLE SPEED . 380/460v-60Hz.....	45
FIGURE 4- 9 . WIRING DIAGRAM, VARIABLE SPEED . 575v -60Hz.....	49
FIGURE 4- 10 . PIPING AND INSTRUMENTATION ILLUSTRATION.....	55
FIGURE 5- 1 . Oil Level Sight Glass.....	56
FIGURE 5- 2 . Oil Change Interval.....	59
FIGURE 5- 3 . Dew Point Chart °F.....	63
FIGURE 5- 4 . Dew Point Chart °C.....	63
FIGURE 6- 1 . Air Flow Chart.....	64
FIGURE 6- 2 . Cooler Access.....	66
FIGURE 7- 1 . Compressor Air Filter.....	68
FIGURE 7- 2 - Pre-Filter and Fan Grill.....	68
FIGURE 8- 1 . Motor Jacking Assembly.....	69
FIGURE 8- 2 . V-Belt Drive Components.....	69
FIGURE 8- 3 - Measuring Angular Misalignment.....	70
FIGURE 9- 1 . Exploded View of EK100 Compressor.....	72
FIGURE 9- 2 . Inlet Valve Assembly.....	73
FIGURE 9- 3 . Inlet Valve Body Hex.....	74
FIGURE 9- 4 - Pressure Relief Valve.....	75
FIGURE 9- 5 - Minimum Pressure Valve and Seat.....	76
FIGURE 9- 6 . Thermostatic Mixing Valve.....	77
FIGURE 9- 7 . Control Panel Cooling Hardware.....	78
FIGURE 9- 8 . VFD Fan Removal.....	79
FIGURE 9- 9 . VFD Fan Disconnect.....	79
FIGURE 9- 10 . VFD Fan Reconnect.....	79
FIGURE 9- 11 . VFD Fan Finger Guard Removal.....	80
FIGURE 9- 12 . VFD Fan Disconnect / Removal.....	80
FIGURE 9- 13 . VFD Fan Reconnect.....	80
FIGURE 9- 14 . VFD Fan Install.....	81
FIGURE 9- 15 - VFD Fan Finger Guard Install.....	81
FIGURE 11- 1 . Maintenance Schedule.....	84



## SECTION 1 GENERAL INFORMATION

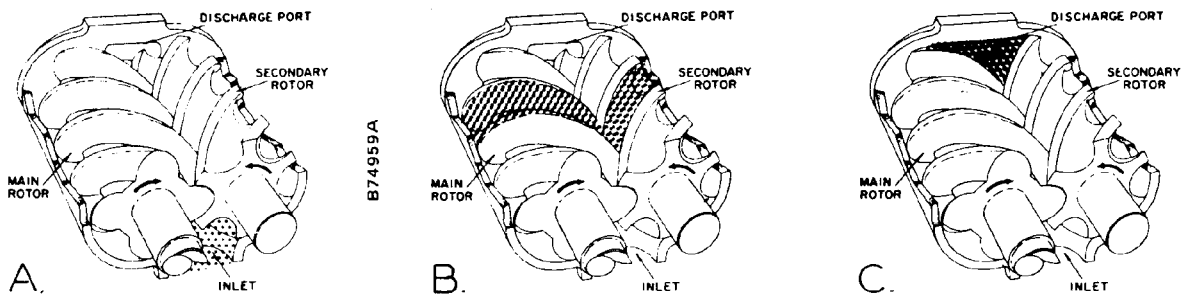

**FIGURE 1-1- COMPRESSOR CYCLE**

**COMPRESSOR** - The rotary screw compressor is a single stage, positive displacement rotary machine using meshing helical rotors to effect compression. Both rotors are supported between high capacity anti-friction bearings located outside the compression chamber. Roller bearings are used at the inlet end of the rotors to carry part of the radial loads. Angular contact ball and roller bearings at the discharge end locate each rotor axially and carry all thrust loads and the remainder of the radial loads.

**COMPRESSION PRINCIPLE (Figure 1-1)** - Compression is accomplished by the main and secondary rotors synchronously meshing in a one-piece cylinder. The main rotor has five (5) helical lobes  $90^\circ$  apart. The secondary rotor has six (6) matching helical grooves  $72^\circ$  apart to allow meshing with main rotor lobes.

The air inlet port is located on top of the compressor cylinder near the drive shaft end. The discharge port is near the bottom at the opposite end of the compressor cylinder. *Figure 1-1 is an inverted view to show inlet and discharge ports.* The compression cycle begins as the rotors unmesh at the inlet port and air is drawn into the cavity between the main rotor lobes and the secondary rotor grooves (A). When the rotors pass the inlet port cutoff, air is trapped in the interlobe cavity and flows axially with the meshing rotors (B). As meshing continues, more of the main rotor lobe enters the secondary rotor groove, normal volume is reduced and pressure increases.

Oil is injected into the cylinder to remove the heat of compression and seal internal clearances. Volume reduction and pressure increase continues until the air/oil mixture trapped in the interlobe cavity by the rotors passes the discharge port and is released to the oil reservoir (C). Each rotor cavity follows the same  $\%11$ -compress-discharge+cycle in rapid succession to produce a discharge air flow that is continuous, smooth and shock free.

**AIR FLOW IN THE COMPRESSOR SYSTEM (Figure 1-3)** - Air enters the air filter and passes through the inlet unloader valve and on into the compression chamber where oil is injected into the air. After compression, the air/oil mixture passes into the oil reservoir where most of the entrained oil is removed by velocity change and impingement and drops back into the reservoir. The air and remaining oil then passes through the air/oil separator. The air then passes through the minimum pressure/check valve, the after cooler and the optional moisture separator and into the plant air lines.

**LUBRICATION, COOLING AND SEALING** - Oil is forced by air pressure from the oil reservoir through the oil cooler, thermostatic mixing valve, and oil filter and discharge into the compressor main oil gallery. A portion of the oil is directed through internal passages to the bearings and shaft oil seal. The balance of the oil is injected directly into the compression chamber to remove heat of compression, seal internal clearances and lubricate the rotors.

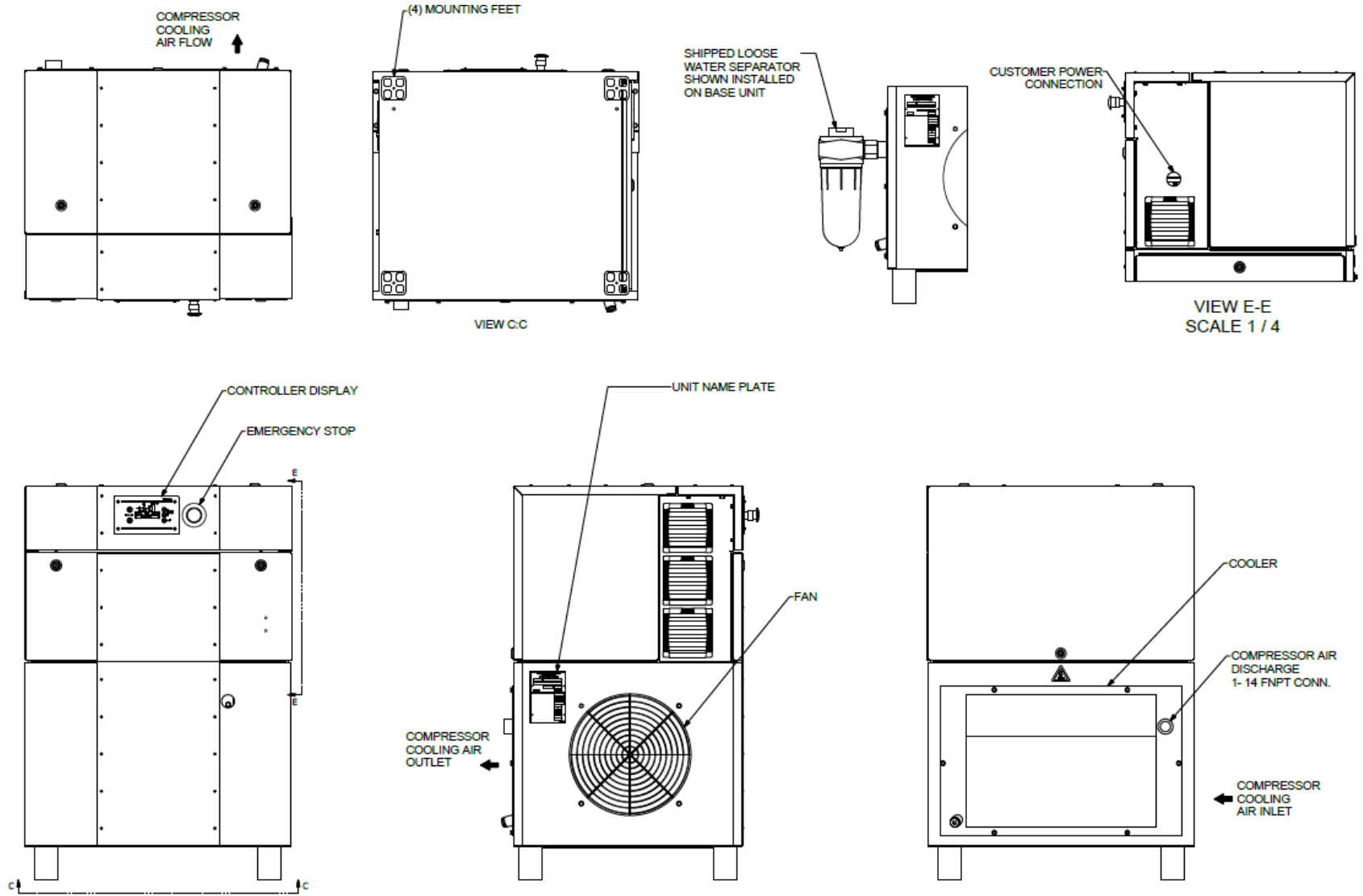

FIGURE 1-2- COMPRESSOR ILLUSTRATION – BASE MOUNT UNIT  
(L15-22 model shown with controller set for “front” display)

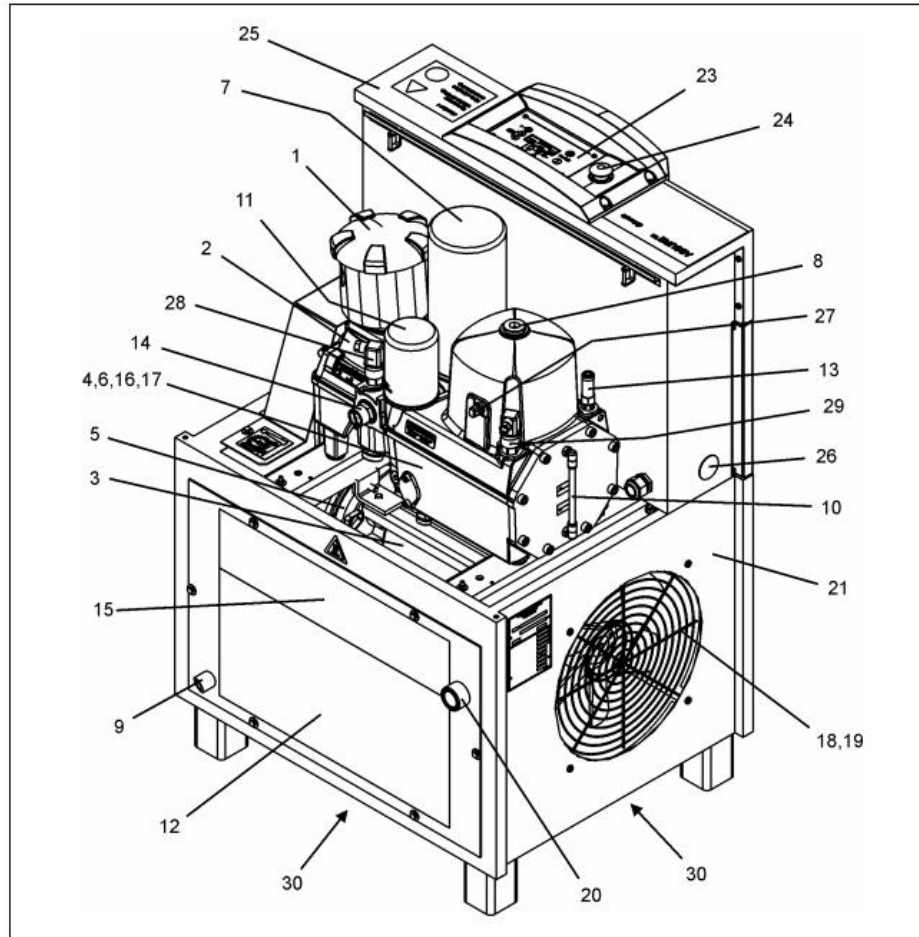
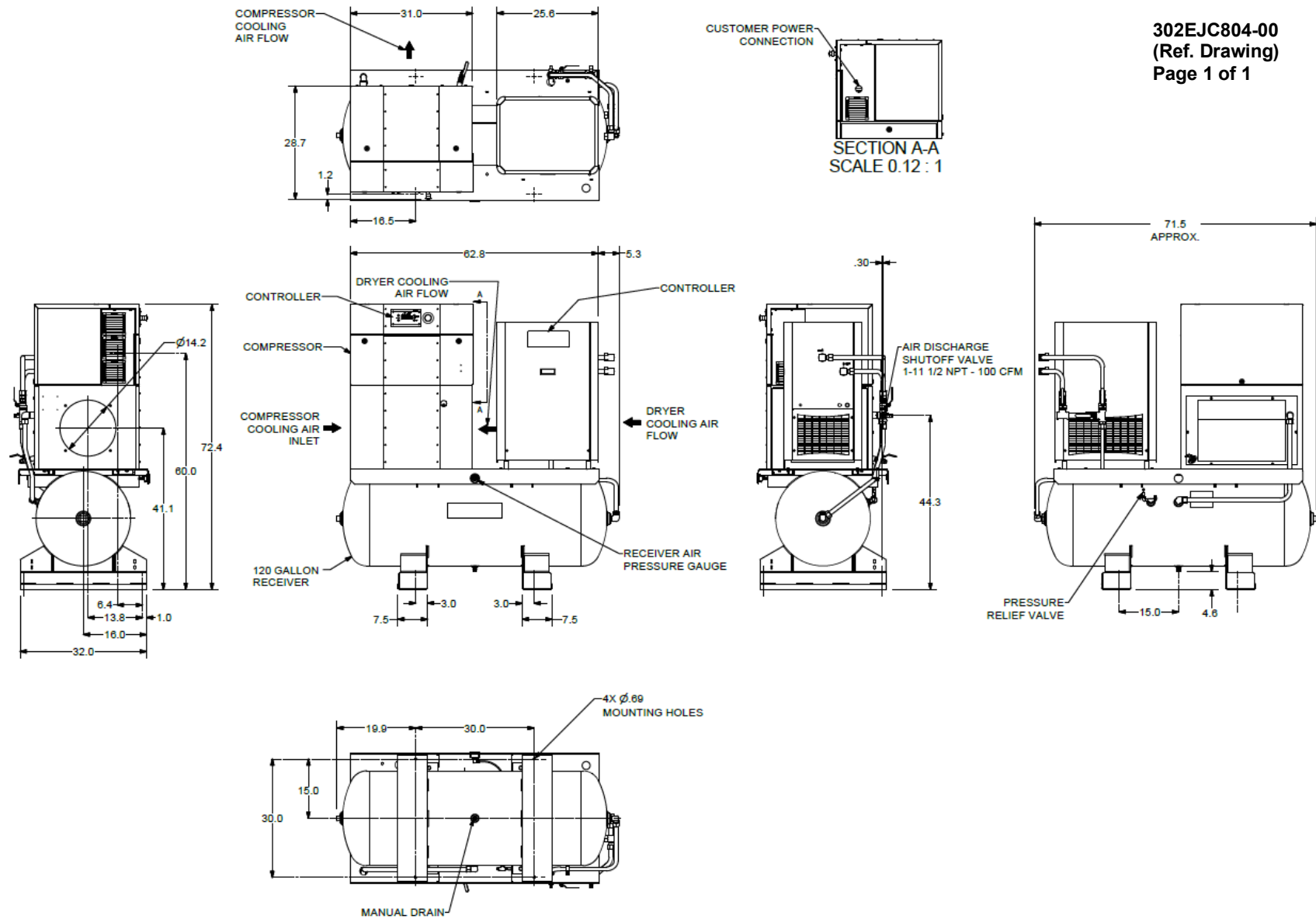

Fig. 2a L15 - L22, L15 RS - L22 RS

- |                        |  |   |
|------------------------|--|---|
| 1 Intake filter        | 12 Oil cooler                            | 23 Control panel                        |
| 2 Suction regulator    | 13 Pressure relief valve                 | 24 Emergency stop button                |
| 3 Electric motor       | 14 Minimum pressure and non-return valve | 25 Switch cabinet                       |
| 4 Screw compressor     | 15 Air cooler                            | 26 Feed cable entry                     |
| 5 Belt drive           | 16 Oil fine separator extractor          | 27 Final compression temperature sensor |
| 6 Pressure reservoir   | 17 Oil temperature regulator             | 28 Network pressure sensor              |
| 7 Oil fine separator   | 18 Cooling fan                           | 29 Final compression pressure sensor    |
| 8 Oil filling port     | 19 Cooling air inlet filter mat          | 30 Opening for lifting gear             |
| 9 Oil drain            | 20 Compressed air outlet                 |   |
| 10 Oil level indicator | 21 Base frame                            |   |
| 11 Oil filter          |  |   |

**FIGURE 1- 3 – COMPRESSOR ILLUSTRATION - INTERNAL DETAILS**  
**(L15-22 model shown with controller set for “top” display)**



**FIGURE 1- 4 – COMPRESSOR ILLUSTRATION – TOTAL SYSTEM  
(L15-22 with 120g receiver and CRN dryer shown)**

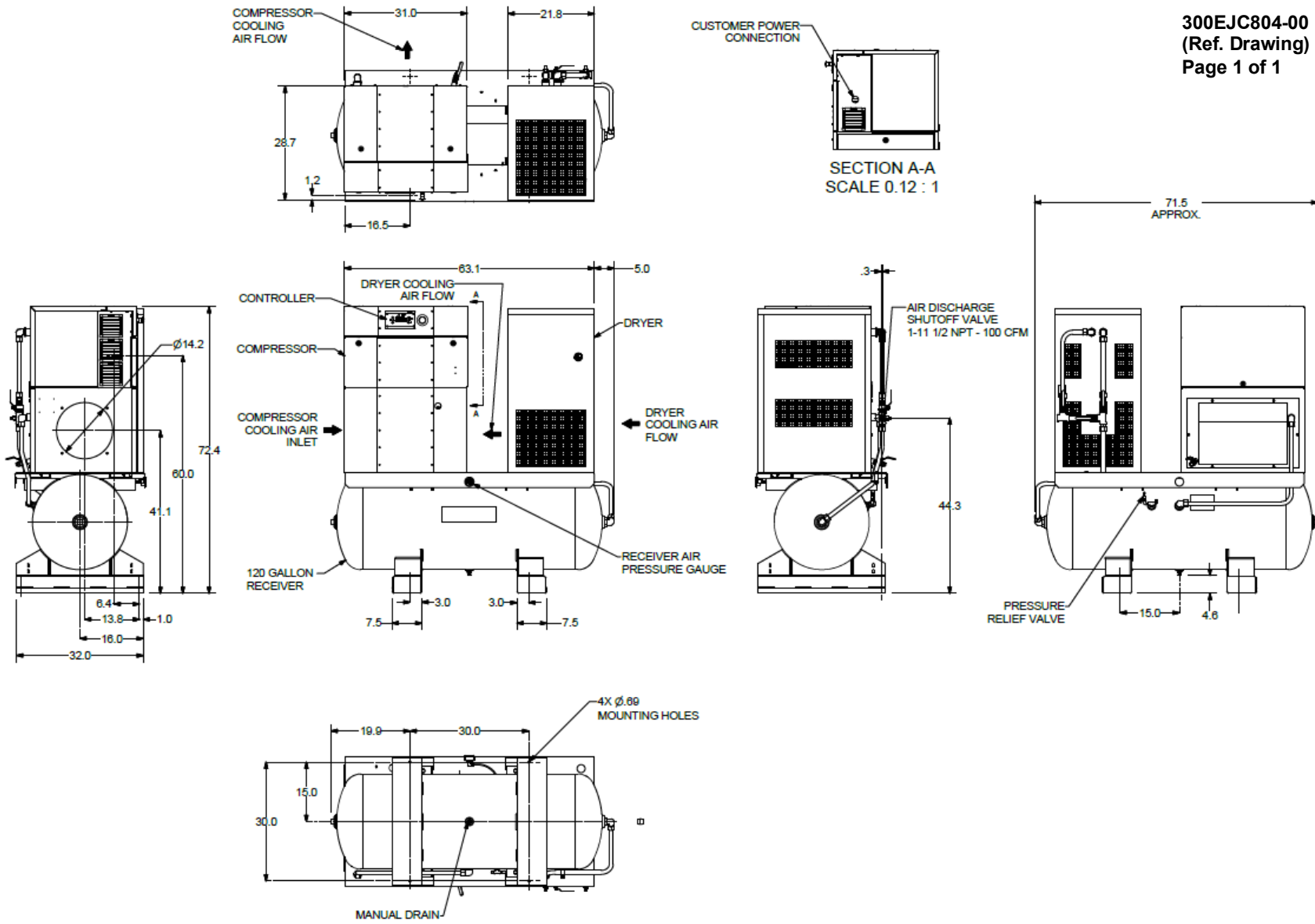

**FIGURE 1- 5 – COMPRESSOR ILLUSTRATION – TOTAL SYSTEM**  
(L15-22 with 120g receiver and GSRN dryer shown)

## SECTION 2 INSTALLATION

---

**GENERAL** - On receipt of the unit, check for any damage that may have been incurred during transit. Report any damage or missing parts as soon as possible.



**Do not electric weld on the compressor or base; bearings can be damaged by passing of current.**

**LIFTING UNIT** - Proper lifting and/or transporting methods must be used to prevent damage. Unit may be moved into location by lift truck.

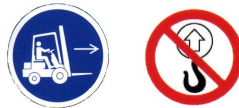

**Lift compressor unit under base only. Do not use other places such as motor, compressor or discharge manifold piping as lifting points.**

**The eyebolts or lugs provided on the motor are for lifting the motor only and should not be used to lift any additional weight. All eyebolts must be securely tightened. When lifting the motor the lifting angle must not exceed 15 degrees. Failure to observe this warning may result in damage to equipment or personal injury.**



**Compressor, air/oil reservoir, separator chamber and all piping and tubing may be at high temperature during and after operation.**

**LOCATION** (Figure 2-2) - The compressor must be installed where it is protected from rain, snow and freezing temperatures, in a clean, well-lighted, well-ventilated area with ample space all around for maintenance. Select a location that provides a cool, clean, dry source of air. In some cases it may be necessary to install the air filter at some distance from the compressor to obtain proper air supply, see %alet Line, page 15.

**AIR-COOLED UNIT** - A combination oil/air cooler is supplied as standard equipment on all air-cooled units. A shaft driven axial fan supplies the ventilation needs for the oil/air cooler and electric motor cooling (Figure 2-2). Air is drawn into the unit through the left side panel, over the motor and discharged through the cooler cores. Do not block the air flow to and from the unit. Allow three and one half (3-1/2) feet to the nearest obstruction on the control box end of the unit. Allow two (2) feet to the nearest obstruction above and on other sides of unit.

For continuous efficiency, the cooler cores must be periodically cleaned with either vacuum or compressed air. If wet cleaning is required, shield motor and spray on a mild soap solution and flush with clean water.

## NOTICE

**Coolers are aluminum; do not use any cleaning solution that is not compatible with aluminum. Use of improper solution may result in damage to the cooler.**

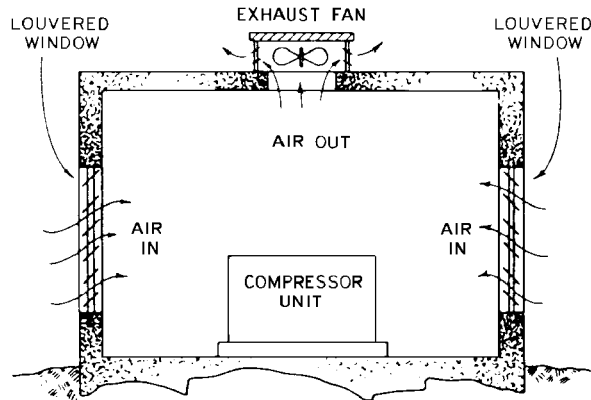

A75119

**FIGURE 2- 1 – TYPICAL COMPRESSOR ROOM**

Minimum Cooling Air Flow Requirements	
L15 / L18 / L22	1942 CFM
L15RS / L18RS / L22RS	1659 CFM

**FIGURE 2- 2 – AIR FLOW CHART**

**FOUNDATION** - The rotary screw compressor requires no special foundation, but should be mounted on a smooth, solid surface. Whenever possible install the unit near level. Mounting bolts are not normally required. However, installation conditions such as piping rigidity, angle of tilt, or danger of shifting from outside vibration or moving vehicles may require the use of mounting bolts and shims to provide uniform support for the base. Belt alignment and tension should be checked after installation. (For information on belt alignment and tension, Section 8.

**OIL SUMP / OIL COOLER DRAIN** . Sump oil and oil cooler charge are drained from a single plugged connection on the lower, left-hand side of the core . see Figure 1-3.

**ENCLOSURE** - The compressor, electric motor, oil cooler and after cooler are mounted inside the enclosure.

Service panels are provided for maintenance access. Be sure to allow enough space around the unit for the panels to be removed. Any of the enclosure panels may be removed by opening the latch and lifting it up slightly.



**Do not operate the compressor with the fan and belt guard removed. Exposed fan and belts may cause injury to personnel.**



**The enclosure doors and panels must be closed and latched while the compressor is operating. Failure to close and latch the doors and panels will cause high temperature shutdowns.**

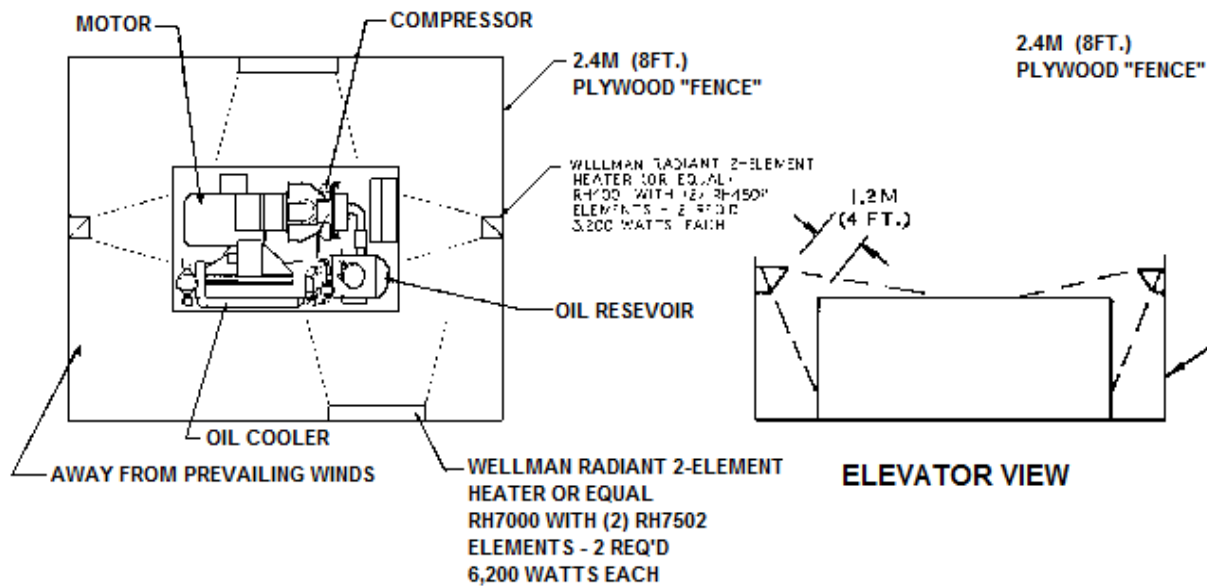

**FIGURE 2- 3 – COLD WEATHER INSTALLATION - TYPICAL**



## INSTALLATION FOR COLD WEATHER OPERATION

It is recommended that the unit be installed inside a shelter that will be heated to temperatures above freezing (32°F, 0°C). This will eliminate many of the problems associated with operating units in cold climates, such as freezing in control lines and downstream of the cooler.

Refer to Engineering Data Sheet 13-9-411 for the advantages of using the heat recovered from rotary compressors. This heat recovery could easily pay for an adequate shelter for the unit.

When the unit must be installed in an outdoors installation and/or exposed to ambient temperatures below freezing (32 F, 0 C), contact Champion for recommendations.

When using a Total System with a compressed air dryer option, refer to Section 10 for details.

Remember unsheltered (outside) installations should be avoided whenever possible. Installation next to a heated building, where enough heat can be used to keep the compressor room above freezing, will save many complications in the operation and installation of the unit.

**AUXILIARY AIR RECEIVER** . When using the base compressor package, an auxiliary air receiver is not required if the piping system is large and provides sufficient storage capacity to prevent rapid cycling. When used, an air receiver should be of adequate size, provided with a relief valve of proper setting, a pressure gauge and a means of draining condensate

**OPTIONAL MOISTURE SEPARATOR/TRAP** - The unit can be provided with an optional stand-alone combination moisture separator and trap that is field-installed downstream of the after cooler.

**CONTROL PIPING** - Control piping is not necessary since the rotary screw unit is factory wired and piped for the control system specified.

**INLET LINE** - The filter is close-coupled to the compressor intake flange, thus no inlet line is used or recommended.

**DISCHARGE SERVICE LINE** . For a stand-alone compressor unit, the discharge service line connection is provided at the outlet of the field installed water separator, which in turn is located at the lower right hand side of the after cooler core.

For a compressor unit integrated into the Total System, the discharge service line connection is provided at the outlet of the dryer bypass loop (when dryer options is furnished) or at the outlet of the receiver vessel.

A hand operated valve, (air service valve) and a separate (swing-type) check valve must be installed between the unit and the customer's air system. If a fast operating valve such as a ball valve is used, it must be closed slowly to give the intake valve time to shut and keep the discharge pressure from spiking.



**The controller has an automatic start/stop sequence built in. You do NOT need to close the air service valve. Closing the air service valve on start-up or prior to shutdown will cause rapid cycling, and could cause a high pressure shutdown.**

When piping two or more rotary screw units on a common discharge line, each unit shall be isolated by the check valve in the unit discharge line.

If a rotary screw and a reciprocating compressor are piped to a common discharge line, an air receiver must be located between the two units.



**Discharge air used for breathing will cause severe injury or death.**

**Consult filtration specialists for additional filtration and treatment equipment to meet health and safety standards.**

**ELECTRICAL WIRING - Standard Units** – The stand alone compressor package is factory wired for all connections from the starter to the motor, for the horsepower and voltage specified on the order. The standard unit is supplied with totally enclosed motors and a NEMA 1 starter and controls enclosure. See location+paragraph in Section 2, for distance to the nearest obstruction on the control box side of the package.

The overload settings are to be selected based on motor nameplate full load amperage.

Perform all wiring in accordance with the National Electrical Code (NFPA-70) and any applicable local electrical codes. Wiring must be performed only by qualified electricians.



**Electrical shock can cause injury or death. Open main disconnect switch, lockout and tag out before working on control box.**

When the compressor unit is integrated into a Total System and the optional compressed air dryer is furnished, the latter shall be provided with a separate source of electrical power.

**Electrical Wire Sizing** - A certified electrician familiar with National Electric Codes and applicable local codes shall size the electrical power wires serving the compressor package. Refer to Figure 2-4 for NEC motor full load currents.

Package Power (HP)	Voltage	NEC FLC (Amps)
20 / 25 / 30	200	62 / 78 / 92
20 / 25 / 30	230	54 / 68 / 80
20 / 25 / 30	380	34 / 43 / 51
20 / 25 / 30	460	27 / 34 / 40
20 / 25 / 30	575	22 / 27 / 32

**FIGURE 2- 4 – Motor FLC**

**GROUNDING** - Equipment must be grounded in accordance with Section 250 of the National Electrical Code.



**Failure to properly ground the compressor package could result in injury or death. Install ground wiring in accordance with the National Electrical Code and any applicable local codes.**

**MOTOR LUBRICATION** - The IEC frame motors used with this compressor package have sealed bearings which have been greased at the factory and require no re-greasing during their operational life. These motors do not have injection or drain ports for re-greasing.

## SECTION 3 STARTING & OPERATING PROCEDURES

---

**PRESTART-UP INSTRUCTIONS** - A new unit received from the factory has been prepared for shipping only. Do not attempt to operate the unit until checked and serviced as follows:

1. **Compressor Oil** - The oil level must be checked before starting the unit and every 8 hours of operation. For instructions on checking the oil and the proper oil level, refer to **Oil level gauge**, Section 5.

Do not mix different type oils. Standard Unit is shipped filled with Champion RotorLub 4000 lubricant which is suitable for the first 4000 hours under normal operating conditions. Other RotorLub lubricants are available. Check the decal on the reservoir to be sure which lubricant is in the machine.

### NOTICE

**Regular maintenance and replacement at required intervals of the oil filter, air filter and air/oil separator is necessary to achieve maximum service and extended drain intervals of RotorLub 4000 lubricant. Use only genuine Champion filters designed and specified for this compressor.**



**Always stop the unit and release air pressure before removing oil filler plug. Failure to release pressure may result in personal injury or death.**

2. **Air Filter** - Inspect the air filter to be sure it is clean and tightly assembled. Refer to SECTION 7 for complete servicing instructions. Be sure the inlet line, if used, is tight and clean.
3. **Package Inlet Filter** (Error! Reference source not found.) Inspect the Pre-Filter to be sure it is clean. Refer to Section 7 for complete servicing instructions
4. **Piping** . Refer to Section 2, **Discharge Service Line** and make sure all piping meets all recommendations.
5. **Electrical** - Check the wiring diagrams furnished with the unit to be sure it is properly wired. See Figures 4-2 to 4-5 for general wiring diagrams and Section 2 for **Electrical Wiring**.
6. **Grounding** - Unit must be properly grounded according to Section 250 of the National Electrical Code.
7. When using a Total System with a compressed air dryer option, refer to Section 10 for details.

**⚠ CAUTION**

**Failure to properly ground the compressor package could result in controller malfunction.**

8. **V-Belt System** - Refer to Section 8 for detailed instruction to unpack and check the alignment of the belt system.

**⚠ CAUTION**

**The motor jacking hardware must be re-configured, the main motor carrier bracket removed, and belts engaged and the belt sheaves alignment checked prior to compressor operation. Failure to do so will prevent compressor operation and/or component damage.**

9. **Rotation** - Check for correct motor rotation by, in quick succession, starting and stopping the compressor system. Note that the controller can also detect reverse motor rotation by sensing a vacuum pressure, but this may damage the compressor by prolonged operation under reverse rotation. If motor reverse rotation is confirmed, follow the appropriate lockout/tagout procedure to isolate the package from the electrical grid, reverse any two motor leads connected to the package or motor, restore electrical power to the package, and re-check rotation.

**⚠ CAUTION**

**Operation with incorrect motor rotation can damage equipment and cause oil eruption from the compressor inlet. When checking motor rotation, induce minimum rotation (less than one revolution if possible). Never allow motor to reach full speed. The compressor unit's direction of rotation must be checked every time the compressor package or its main motor is reconnected to the power supply.**

**⚠ DANGER**



**Electrical shock can cause injury or death. Open main disconnect switch, lockout and tagout before working on control box.**

10. For your convenience, the following excerpt from the Controller manual is presented to assist in programming the basic operating parameters. However, we strongly recommend you read the Controller manual before attempting operating the compressor package.

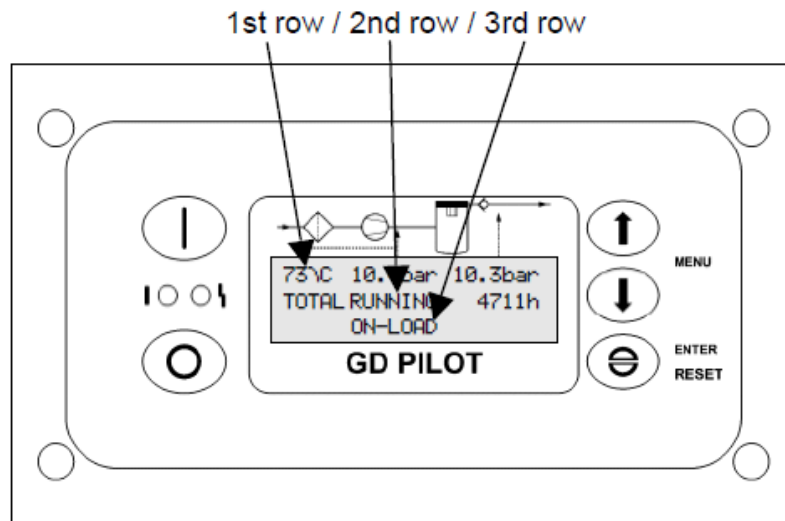

**FIGURE 3- 1 – GD Pilot Controller Layout and Main Screen**

- **Controller Hardware layout.**
  - See Fig 3-1 for the layout of the main screen and input devices.
  - The ( I ) key switches unit on.
  - The ( O ) key switches unit off.
  - The ( E ) key enters a selection and clears a fault.
  - The ( ↑↓ ) keys, hit simultaneously, call up or exit a menu/submenu.
  - The ( ↑ ) key navigates to a previous submenu/menu or increases a parameter value.
  - The ( ↓ ) key navigates to a next submenu/menu or decreases a parameter value.
  - Display info (1<sup>st</sup> row): AE discharge temp and press, MPV discharge press (permanent).
  - Display info (2<sup>nd</sup> row): Menus. Total Running Hrs. default menu.
  - Display info (3<sup>rd</sup> row): Status, Fault and Warning messages. Load status default menu.
- **Setting the Cut-out Pressure**
  - Navigate to the [Control Menu] by pressing simultaneously the ( ) keys.
  - Navigate to the [Cut out] submenu with the ( ↓ ) key. Adjust the pressure to a value between 1 to 6 psig above the desired operating pressure by using the ( ↑↓ ) keys.
- **Setting the Cut-in Pressure**
  - Navigate to the [Cut in] submenu with the ( ↓ ) key. Adjust the pressure to a value at least 1 to 6 psig below that of the desired operating pressure by using the ( ↑↓ ) keys.
  - For variable speed models which use a variable frequency drive, the %Cut-in+submenu is replaced with a %Target+submenu. In this case, adjust the pressure to a value equal to the desired operating pressure.
- **Selecting the operating mode**
  - Navigate to the [Automatic Operation] submenu with the ( ↓ ) key . this is the recommended mode to use until you become familiar with the Controller manual and other operating modes available.

**⚠ DANGER**



Operation at excessive discharge air pressure can cause personal injury or damage to equipment. Do not adjust the operating discharge air pressure above the maximum stamped on the unit nameplate.

11. **Enclosure** - Check for damaged panels or doors. Check all screws and latches for tightness. Be sure doors are closed and latched.

**⚠ DANGER**



The compressor starts and stops automatically. Automatic restarting can cause injury or death. Open, lockout and tagout main disconnect and any other circuits before servicing the unit.

**⚠ WARNING**

The enclosure doors must be closed and latched to keep the compressor package from overheating when the compressor is running.

**⚠ WARNING**

After an emergency stop, be sure that the pressure in the air/oil reservoir is less than 5 psig. Wait one minute or more before restarting.

**⚠ WARNING**

The controller has an automatic start/stop sequence built in. You do NOT need to close the air service valve. Closing the air service valve on start-up or prior to shutdown will cause rapid cycling, and could cause a high pressure shutdown.

**STARTING THE UNIT** - Observe the following starting procedures:

**Unit Cold or Hot:**

1. When using a Total System with a compressed air dryer option, refer to Section 10 for operating details.
2. Open the air service valve (customer furnished) between the main air system and the check valve on the package.
3. Turn on power to the compressor package. Press the **(⊖)** key to clear faults (if present), then press the **( I )** key to start the unit.
4. Run for approximately several minutes until the temperature stabilizes.
5. The unit is equipped with a minimum (70psig) pressure/check valve. No special procedure is required to maintain the unit reservoir pressure.

**DAILY CHECK** - Refer to Maintenance Schedule, Section 11.

**STOPPING THE UNIT:**

1. To stop compressor operation, press the **(O)** key.
2. Wait approximately one minute to allow the compressor to stop. The oil reservoir will automatically blow down as the motor stops.
3. When using a Total System with a compressed air dryer option, refer to Section 10 for operating details.



## SECTION 4 CONTROLS & INSTRUMENTATION

---

### GENERAL DESCRIPTION

The Champion rotary screw compressor is pre-wired with all controls, motor, and starter for the voltage and horsepower at the time of ordering. It is necessary only to connect the compressor unit to the correct power supply and to the shop airline. A standard package unit consists of the EK100 compressor, oil separation module, air/oil cooling and filtration system, TEFC electric main motor, Wye/Delta reduced voltage magnetic starter (variable speed drive option available) housed in an NEMA 1 enclosure, and control components as described below.

**ELECTRONIC CONTROLLER AND STARTER ASSEMBLY HARDWARE** - See to the Wiring Diagrams listed [by voltage] at the end of this section, for more details on the location of the referred hardware.

**GD Pilot Controller** - The compressor package features the GD Pilot controller, which integrates all the control functions under microprocessor control - see Figure 4-1 for general detail of the controller keypad and display. Controller functions include safety and shutdown, compressor regulation, operator control and advisory/maintenance indicators. The keypad and display provides a logical and easily operated control of the compressor and indication of its condition. The controller is factory adjusted for the compressor package, but allows tuning for specific applications.

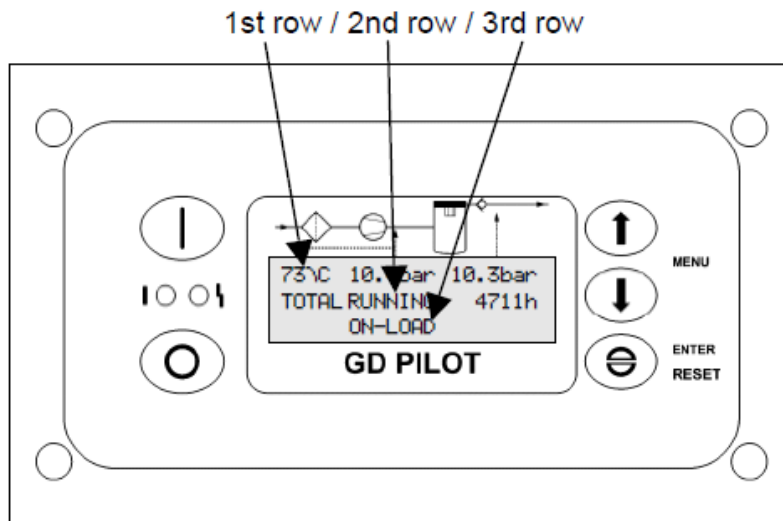

FIGURE 4- 1 – GD Pilot Controller Layout and Main Screen

**Emergency Stop Pushbutton** - This is a maintained pushbutton, and removes power from the controller outputs regardless of controller status. It is located on the electrical panel door, below the controller keypad. This should be used for emergency purposes only - use the (O) key for normal controlled stopping.

**Control Transformer** – A control transformer is provided to supply 230 and 24 VAC control power supply.

**Fuse Blocks** – Fuse blocks provide input and output side protection for the control transformer.

**Terminal Strip** - This device provides an interconnection between the GD Pilot controller and the low voltage hardware such as sensors and switches within the enclosure.

**Main Starter** - For Fixed Speed variant models, a Wye/Delta reduced voltage starter provides control and overload protection for the main drive motor. The overloads are adjustable and are factory set based on the motor nameplate amps and the instructions located inside the control box door. For Variable Speed variant models, a variable speed drive provides the overload protection for the main drive motor as well as compressor speed modulation.

Wiring diagrams for the standard configurations are illustrated in the following pages of this section.

## NOTICE



**Read the Operator's Manual before operating the compressor. It is critical that the detailed instructions for the controller, found in the controller manual are read and understood. Once the appropriate parameters have been selected into the controller, compressor operation may commence. For convenience, a "Quick Start" excerpt from the controller manual is shown in Section 3**

**FIELD CONVERSION OF MULTI-VOLTAGE ELECTRICAL SYSTEM** – For fixed speed tri-voltage models to convert the compressor package from its as-built voltage configuration to one of its optional ones, contact Gardner Denver and request %nstructions . Tri-Voltage Conversion+; document TED000631.

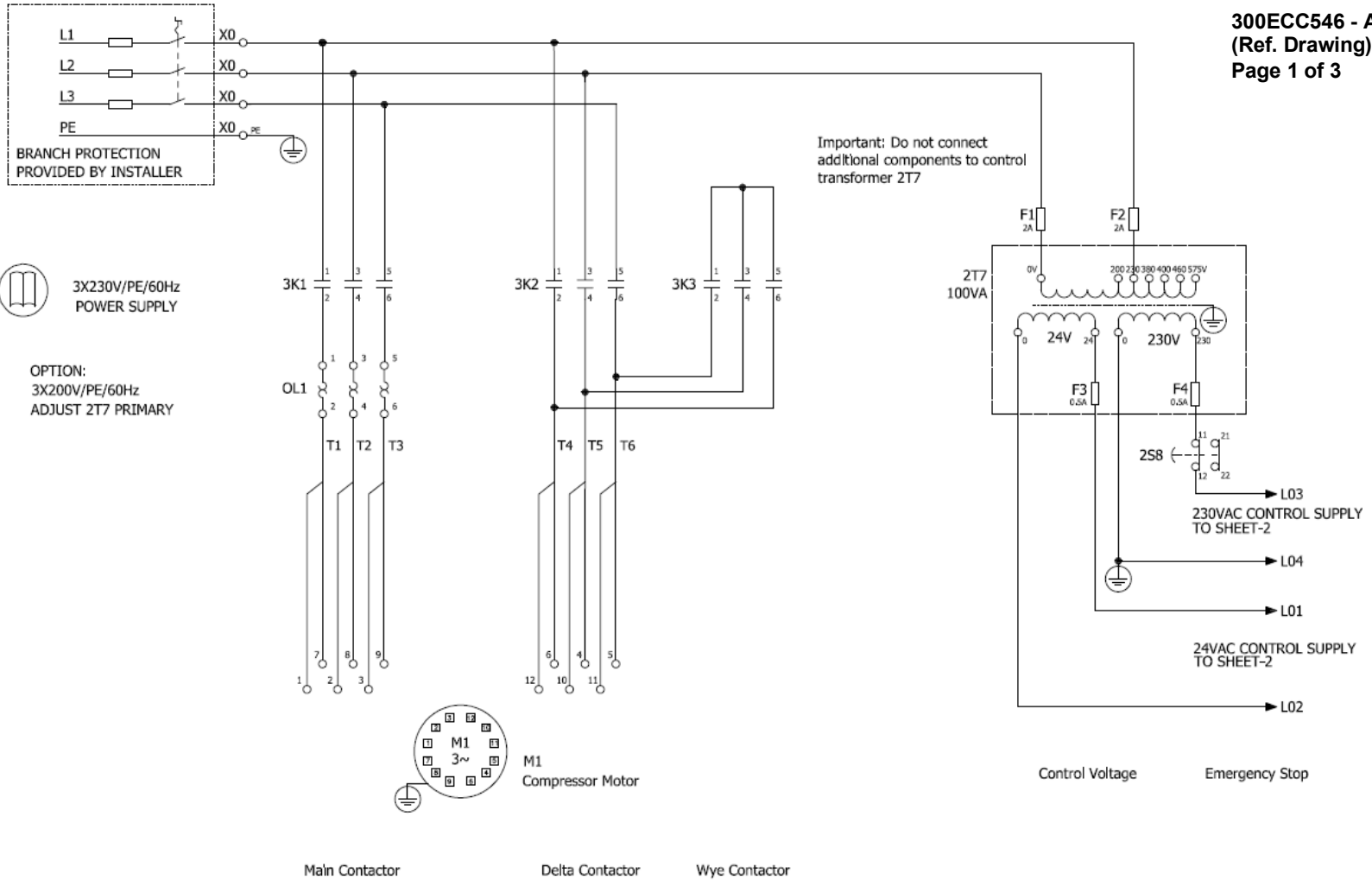

MOTOR LEAD NAMING TRANSLATION											
1	2	3	4	5	6	7	8	9	10	11	12
U1	V1	W1	U2	V2	W2	U3	V3	W3	U4	V4	W4

FIGURE 4- 2 – WIRING DIAGRAM, FIXED SPEED – 200-230v 50/60Hz

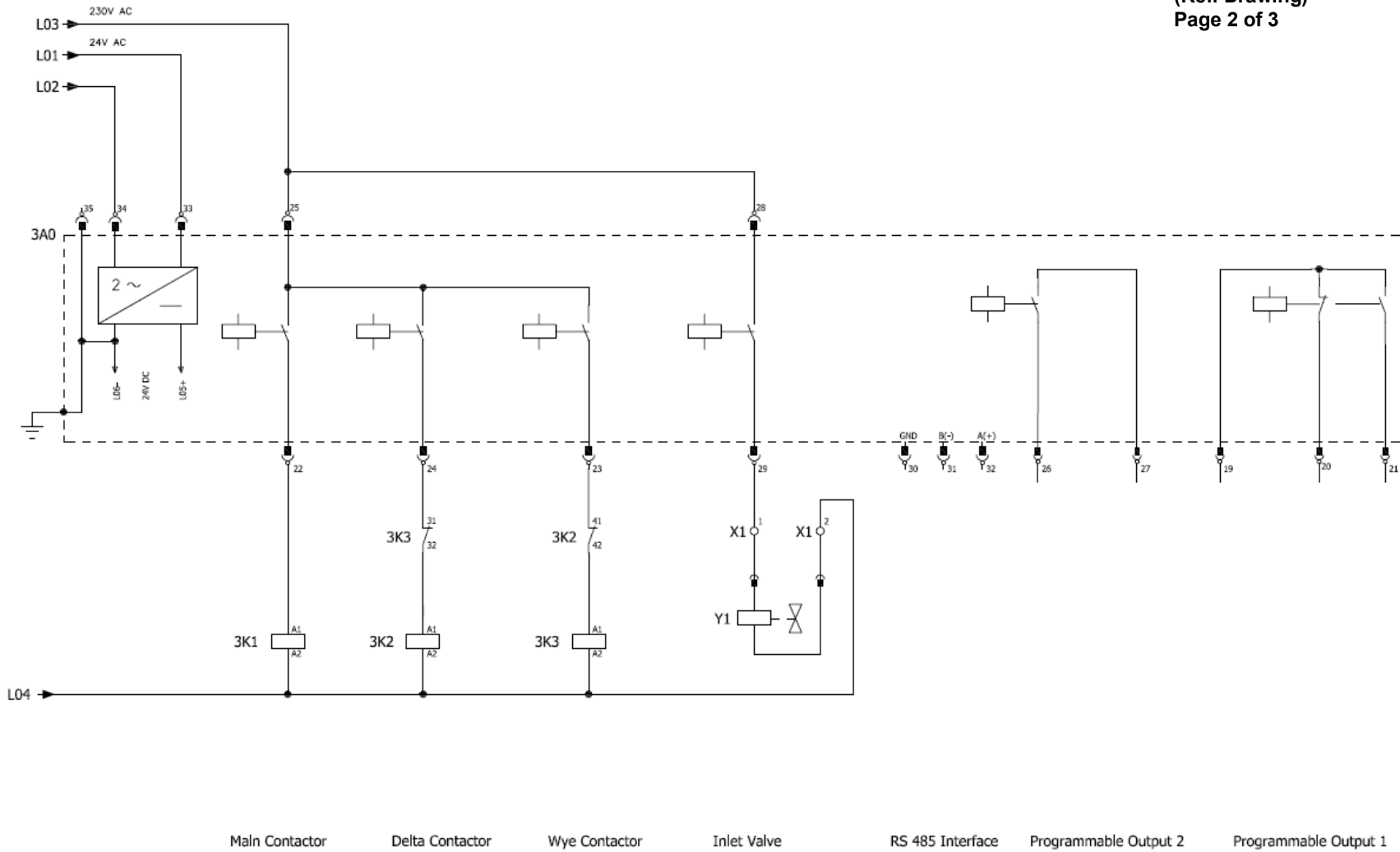

FIGURE 4- 2 – WIRING DIAGRAM, FIXED SPEED – 200-230v 50/60Hz

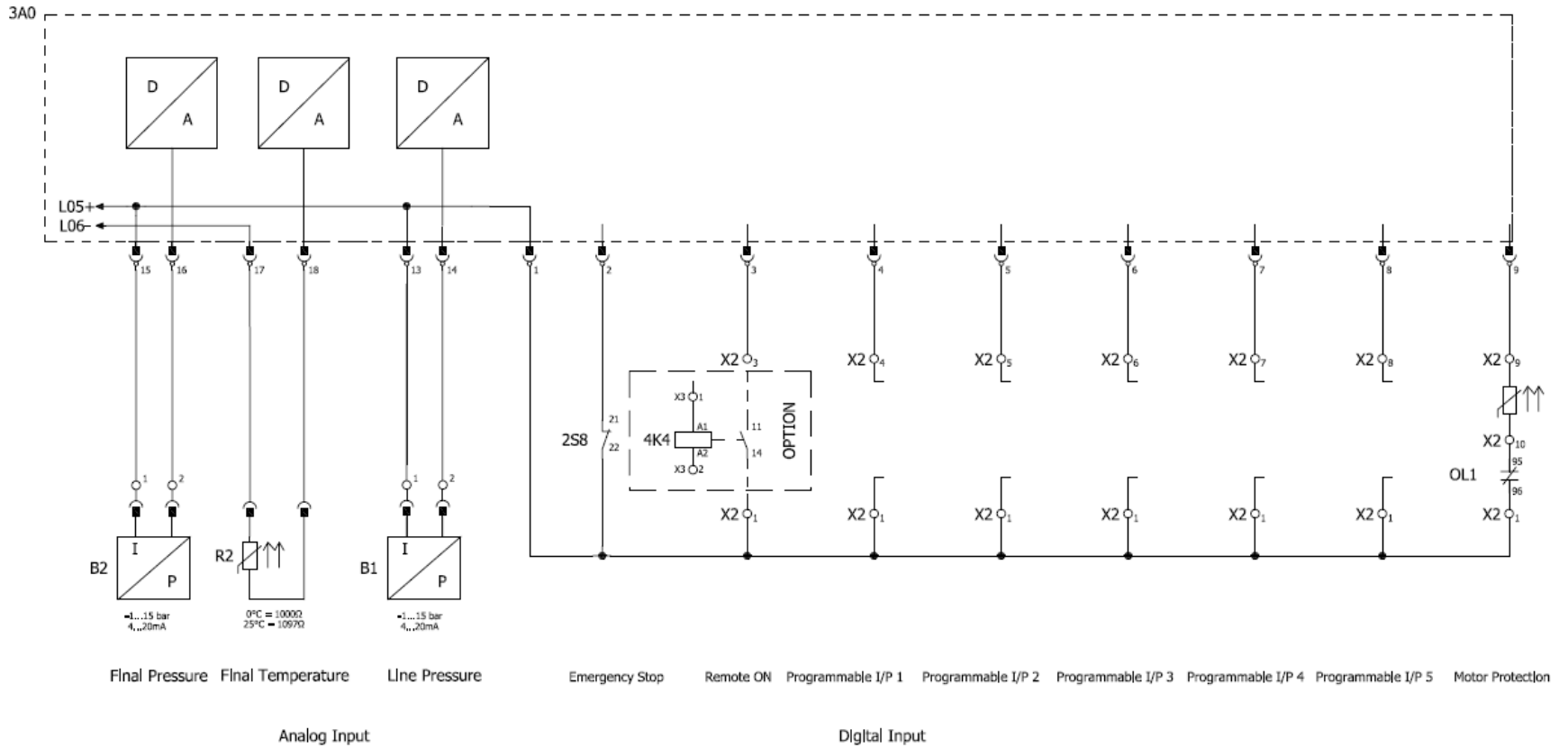

FIGURE 4- 2 – WIRING DIAGRAM, FIXED SPEED – 200-230v 50/60Hz

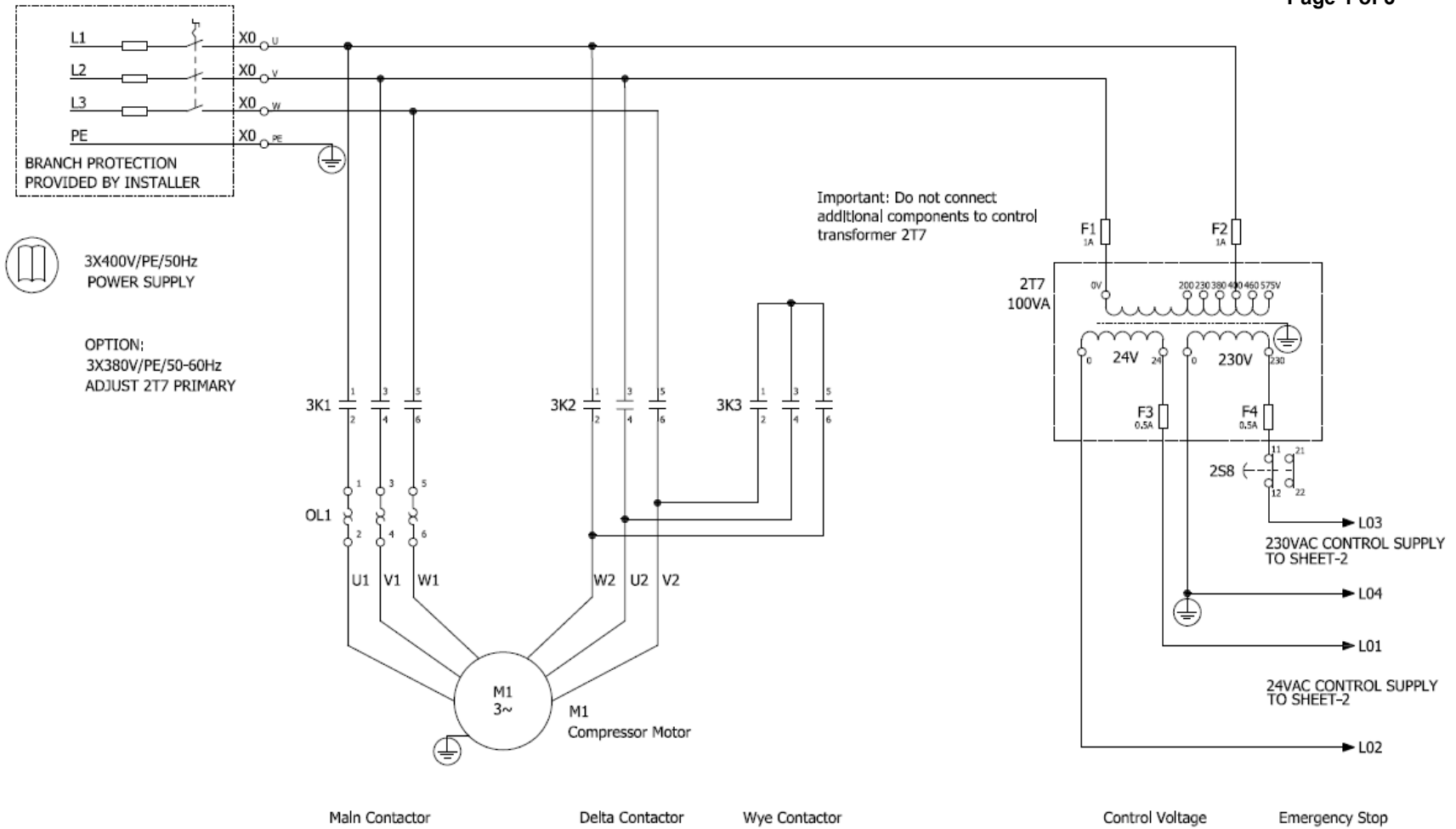

FIGURE 4- 3 – WIRING DIAGRAM, FIXED SPEED 380-400V 50/60Hz

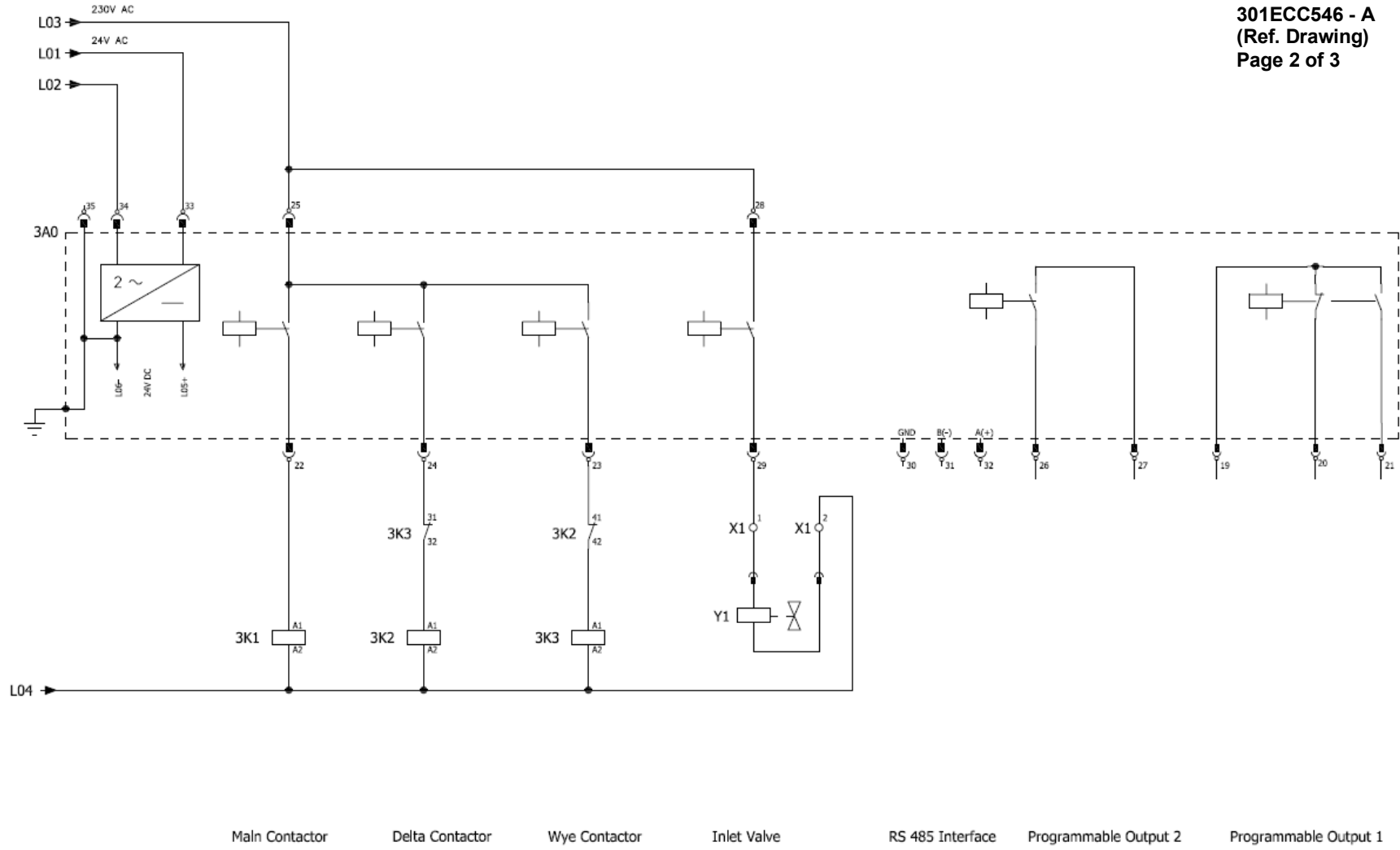

FIGURE 4- 3 – WIRING DIAGRAM, FIXED SPEED 380-400V 50/60Hz

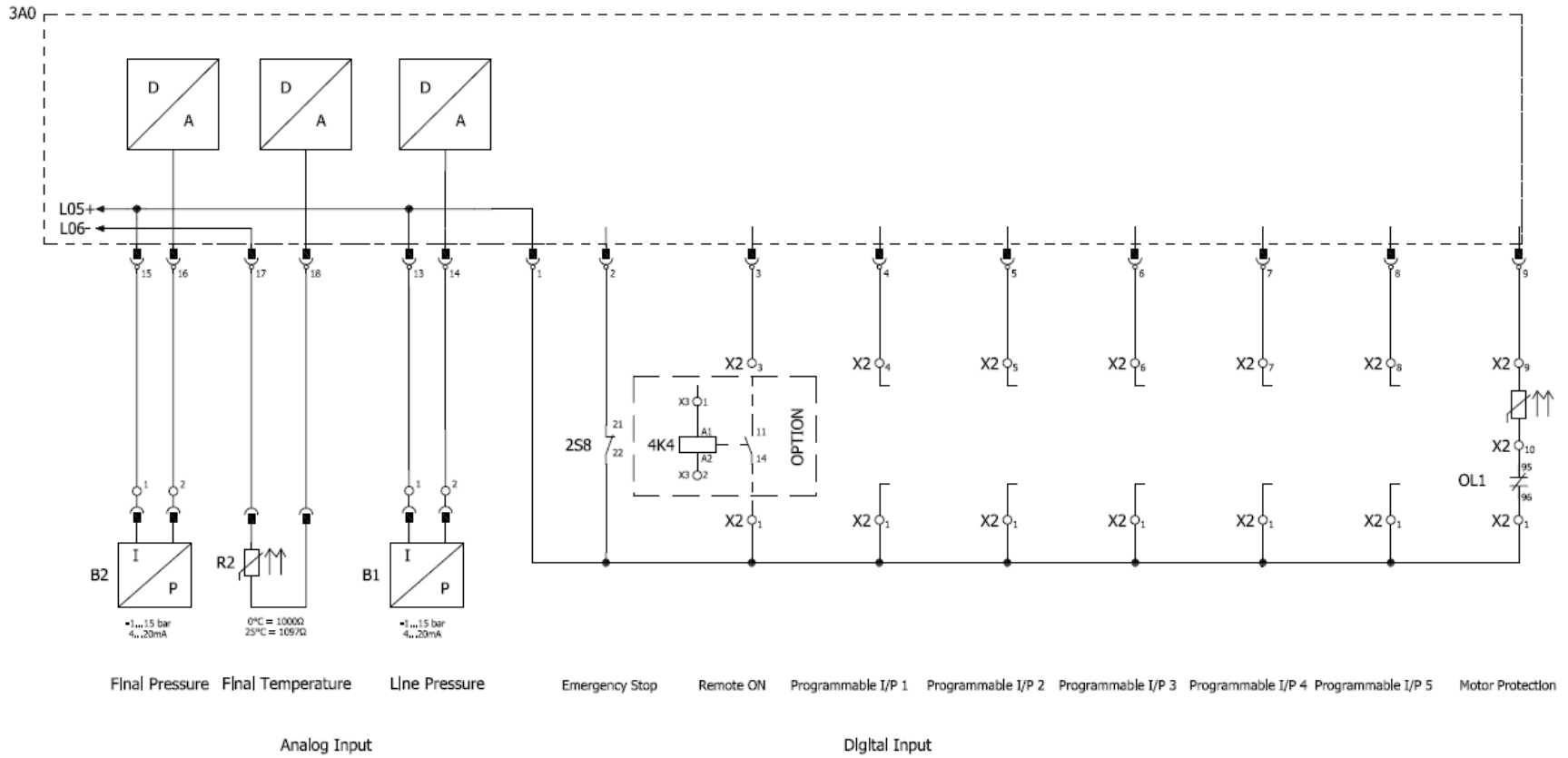
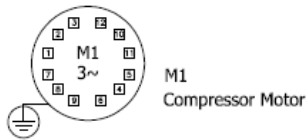
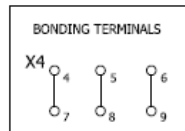
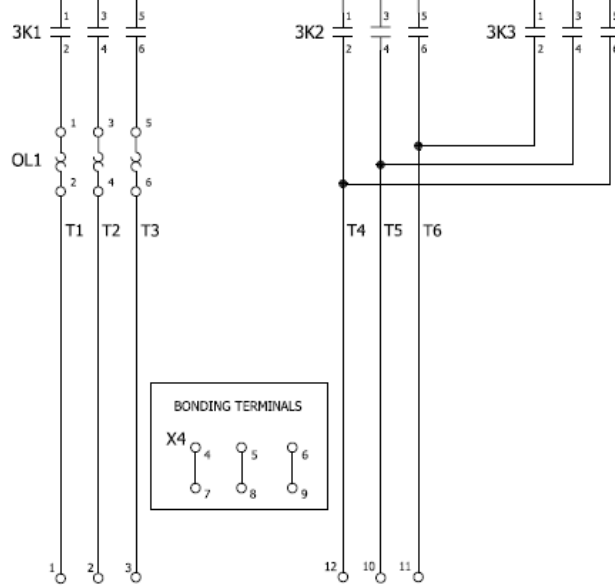
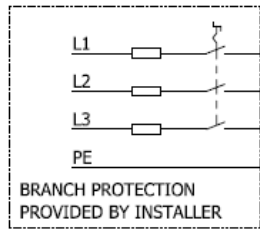
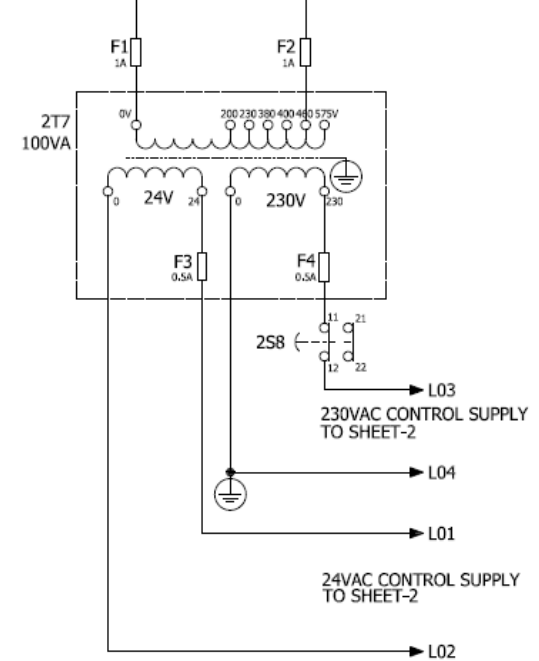

FIGURE 4- 3 – WIRING DIAGRAM, FIXED SPEED 380-400V 50/60Hz





460V



Control Voltage      Emergency Stop

13-25-632 Page 32

MOTOR LEAD NAMING TRANSLATION											
1	2	3	4	5	6	7	8	9	10	11	12
U1	V1	W1	U2	V2	W2	U3	V3	W3	U4	V4	W4

Main Contactor

Delta Contactor

Wye Contactor

FIGURE 4- 4 – WIRING DIAGRAM, FIXED SPEED – 460v 60Hz

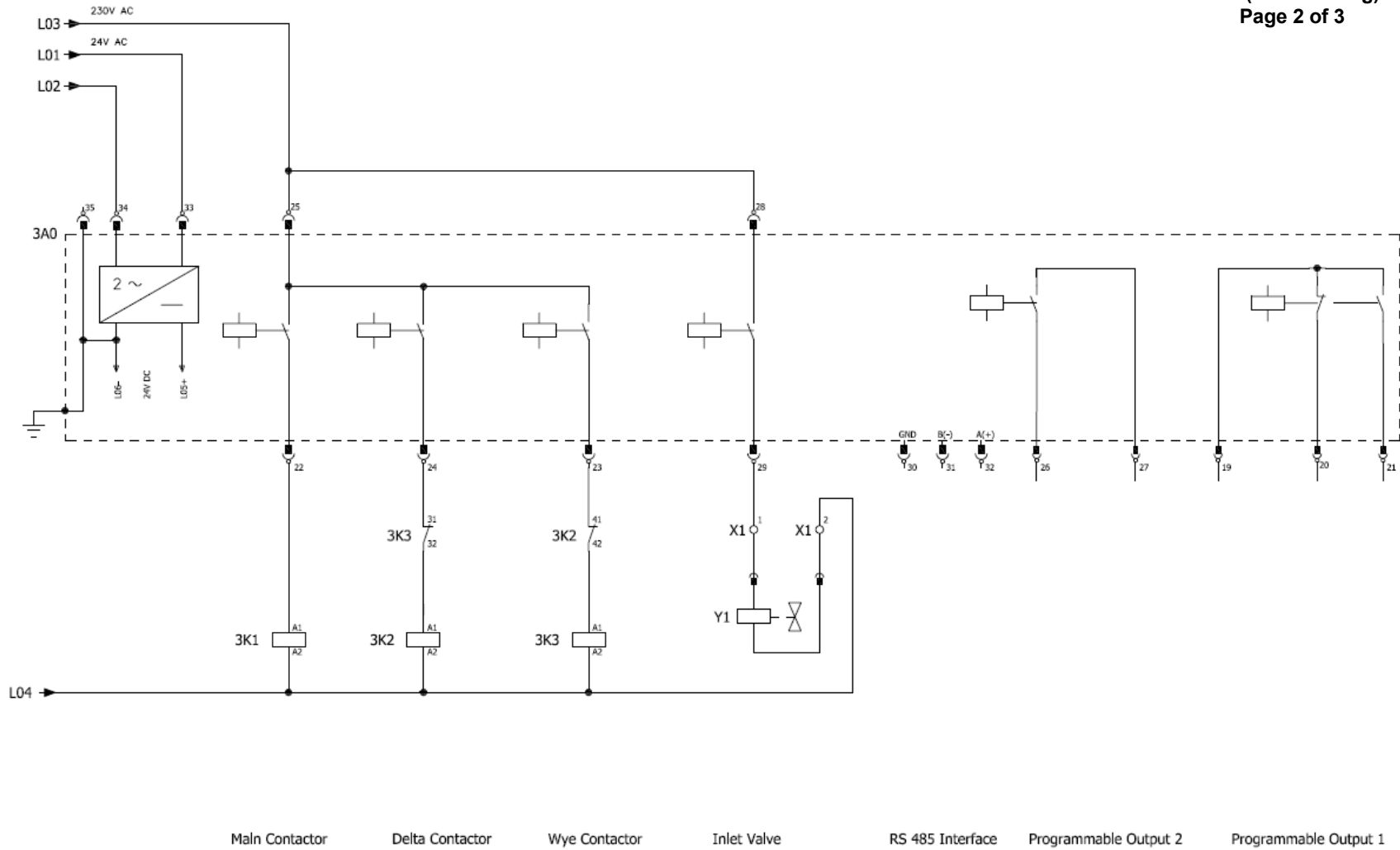

FIGURE 4- 4 – WIRING DIAGRAM, FIXED SPEED – 460v 60Hz

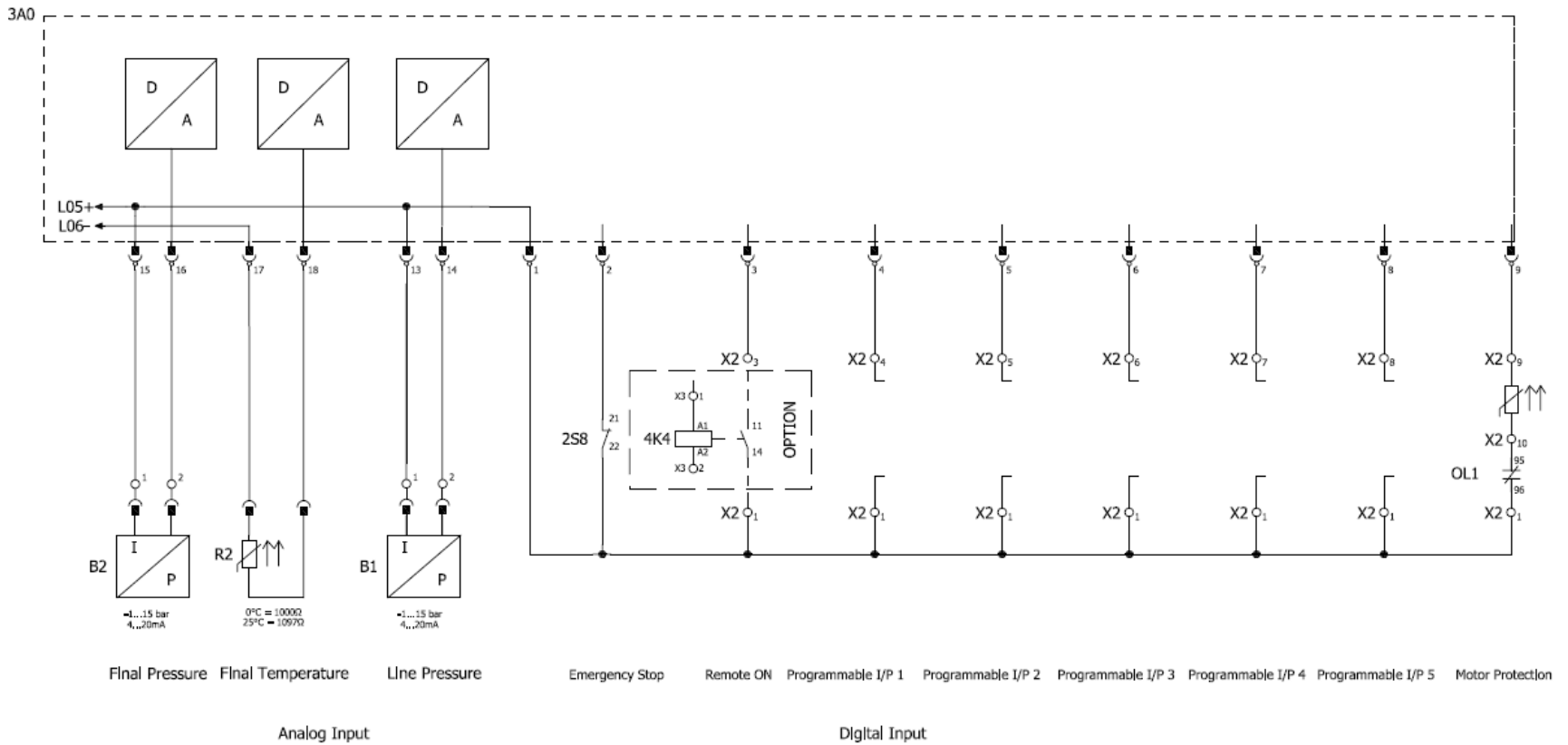

FIGURE 4- 4 – WIRING DIAGRAM, FIXED SPEED – 460v 60Hz

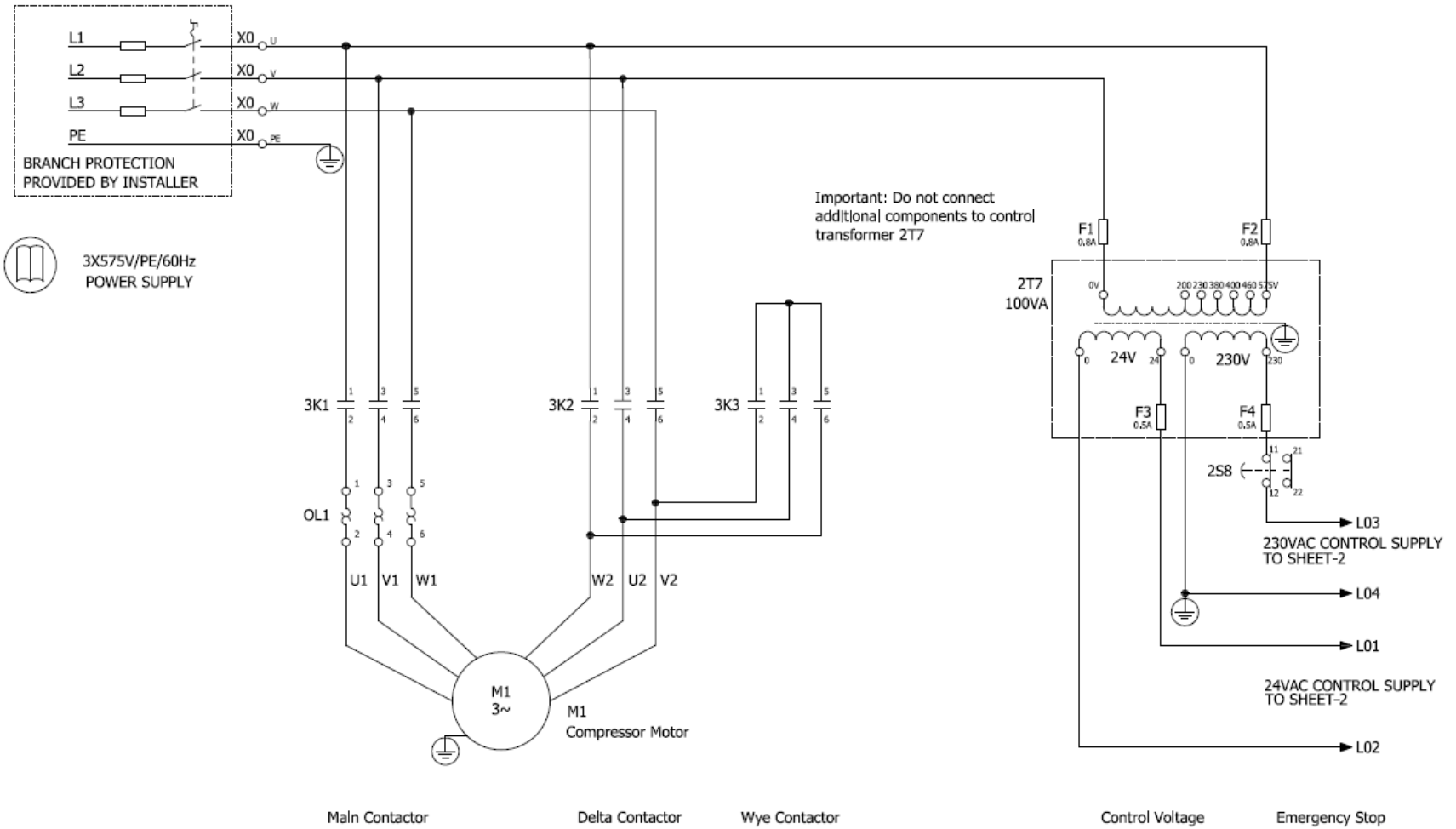

FIGURE 4- 5 – WIRING DIAGRAM, FIXED SPEED – 575v 60Hz

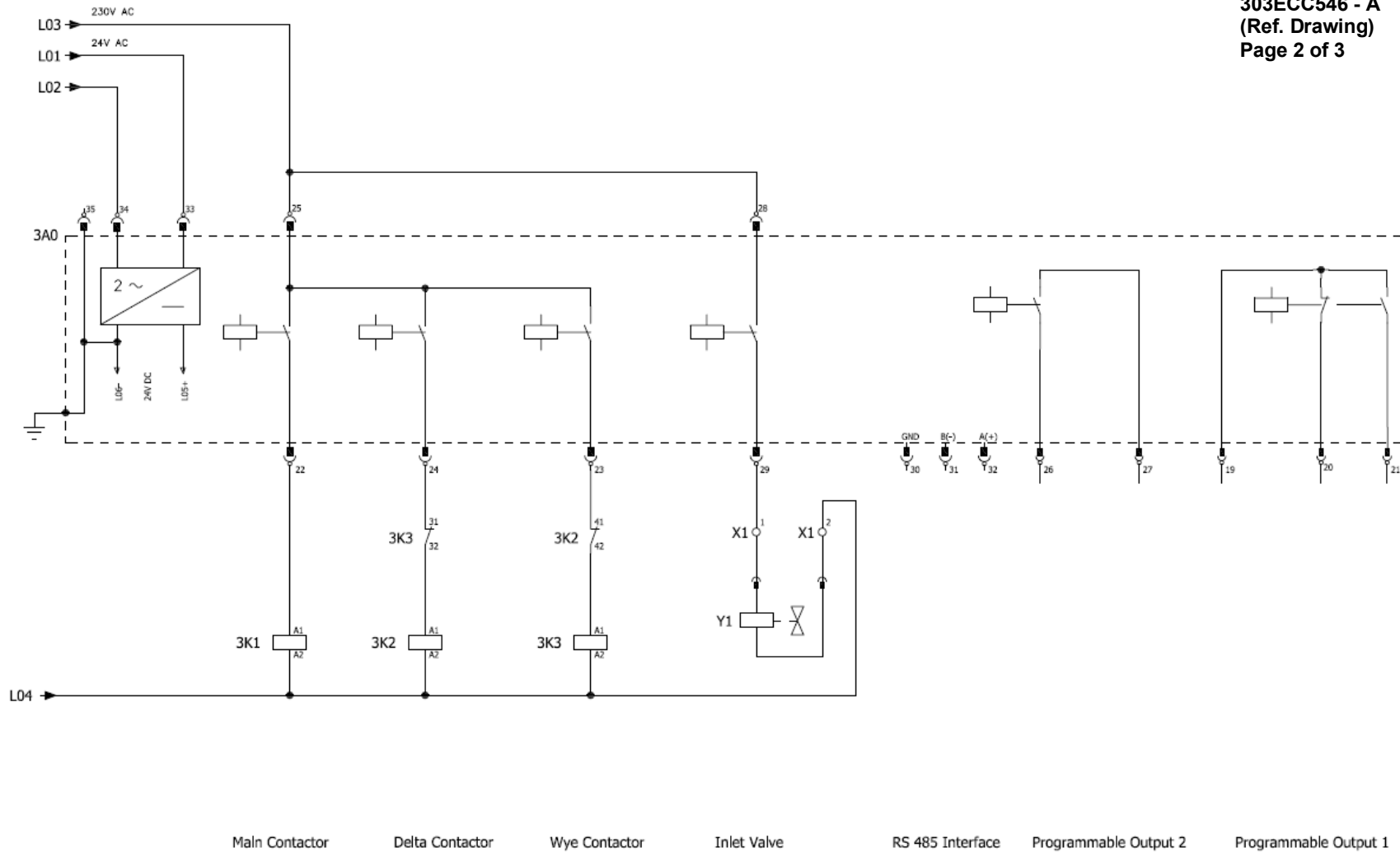

FIGURE 4- 5 – WIRING DIAGRAM, FIXED SPEED – 575v 60Hz

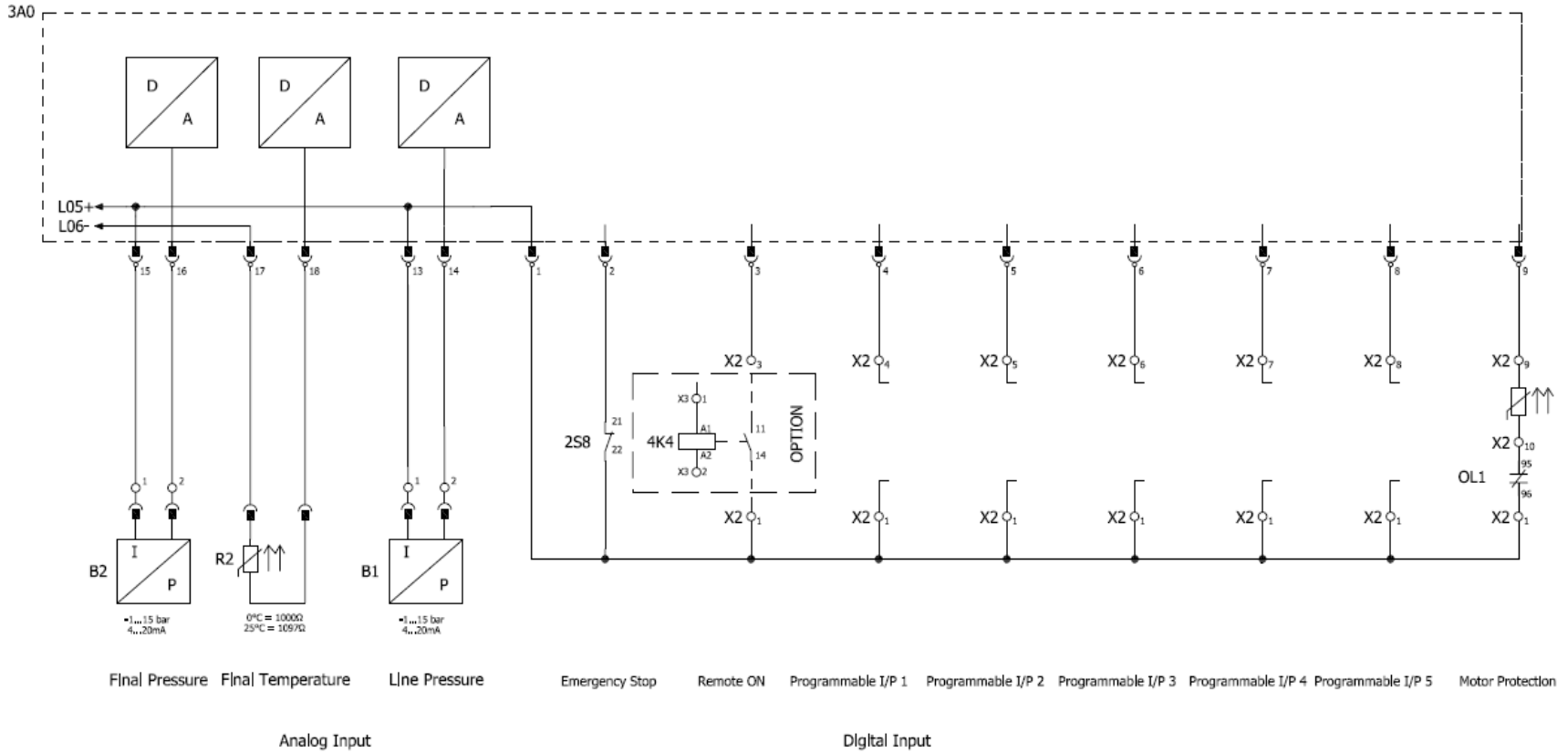

FIGURE 4- 5 – WIRING DIAGRAM, FIXED SPEED – 575v 60Hz

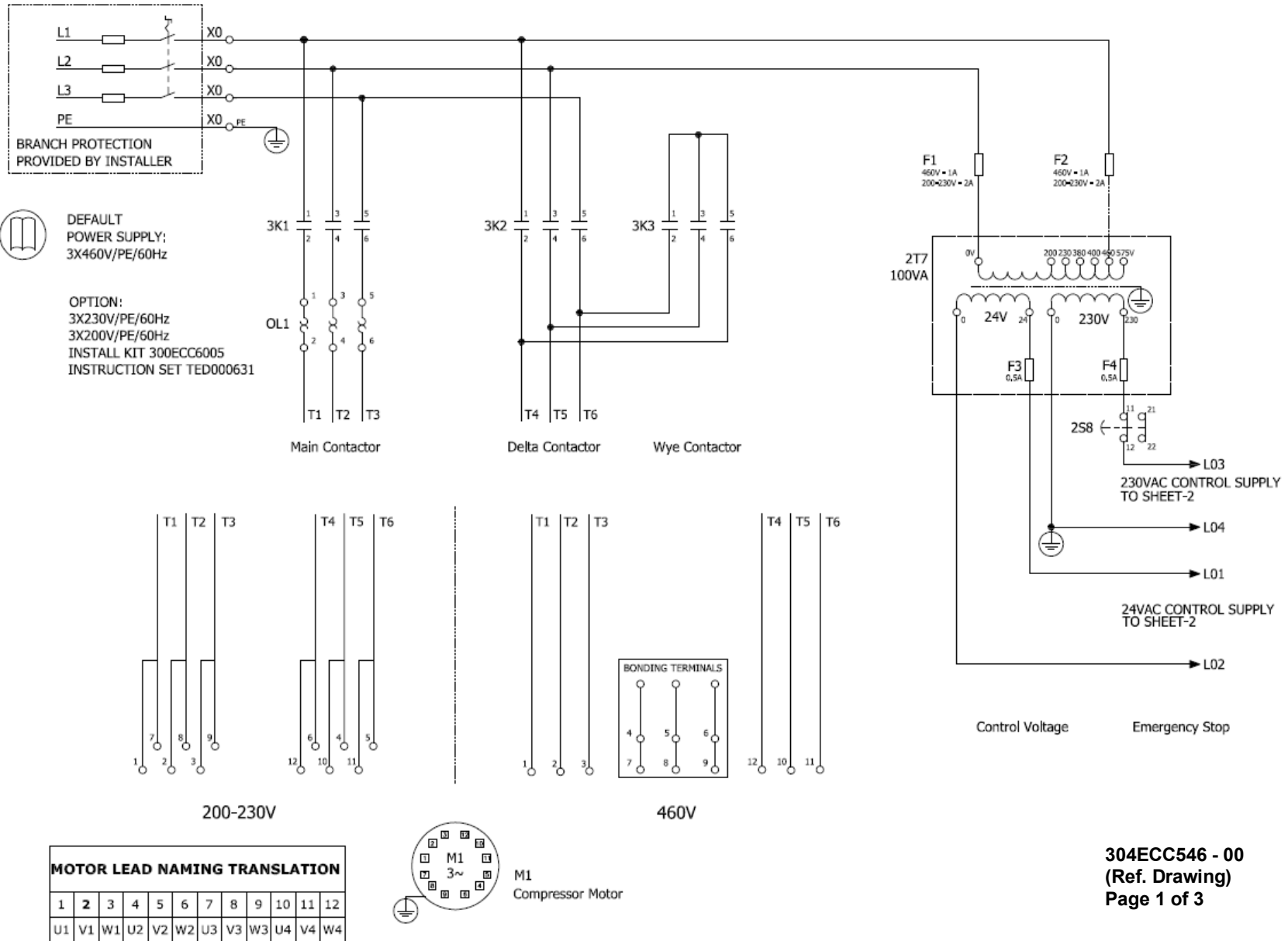
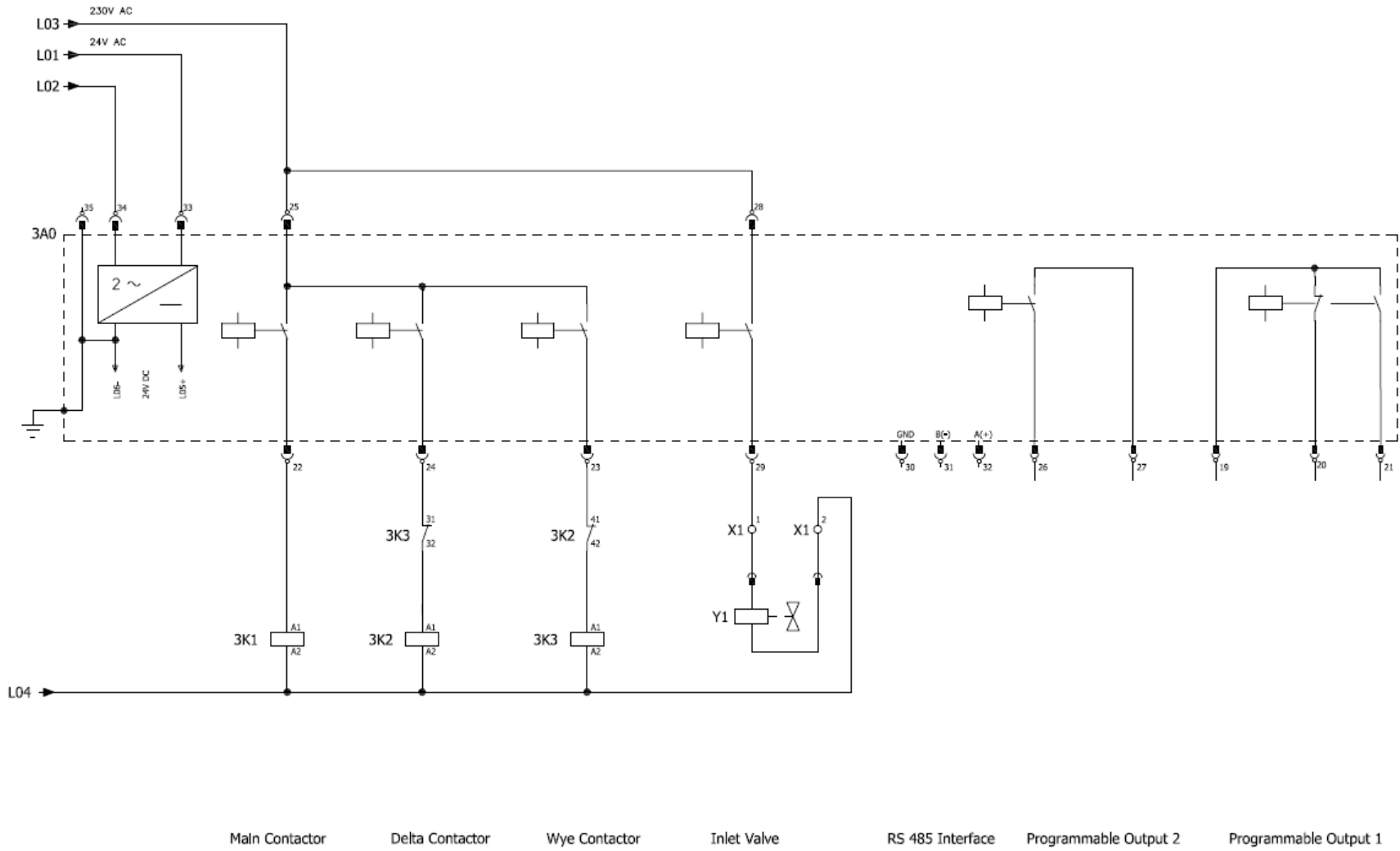

FIGURE 4- 6 – WIRING DIAGRAM, FIXED SPEED –TRI-VOLTAGE– 200-230/460v 60Hz



304ECC546 - 00  
(Ref. Drawing)  
Page 2 of 3

Figure 4- 6 -- WIRING DIAGRAM, FIXED SPEED -TRI-VOLTAGE- 200-230/460v 60Hz



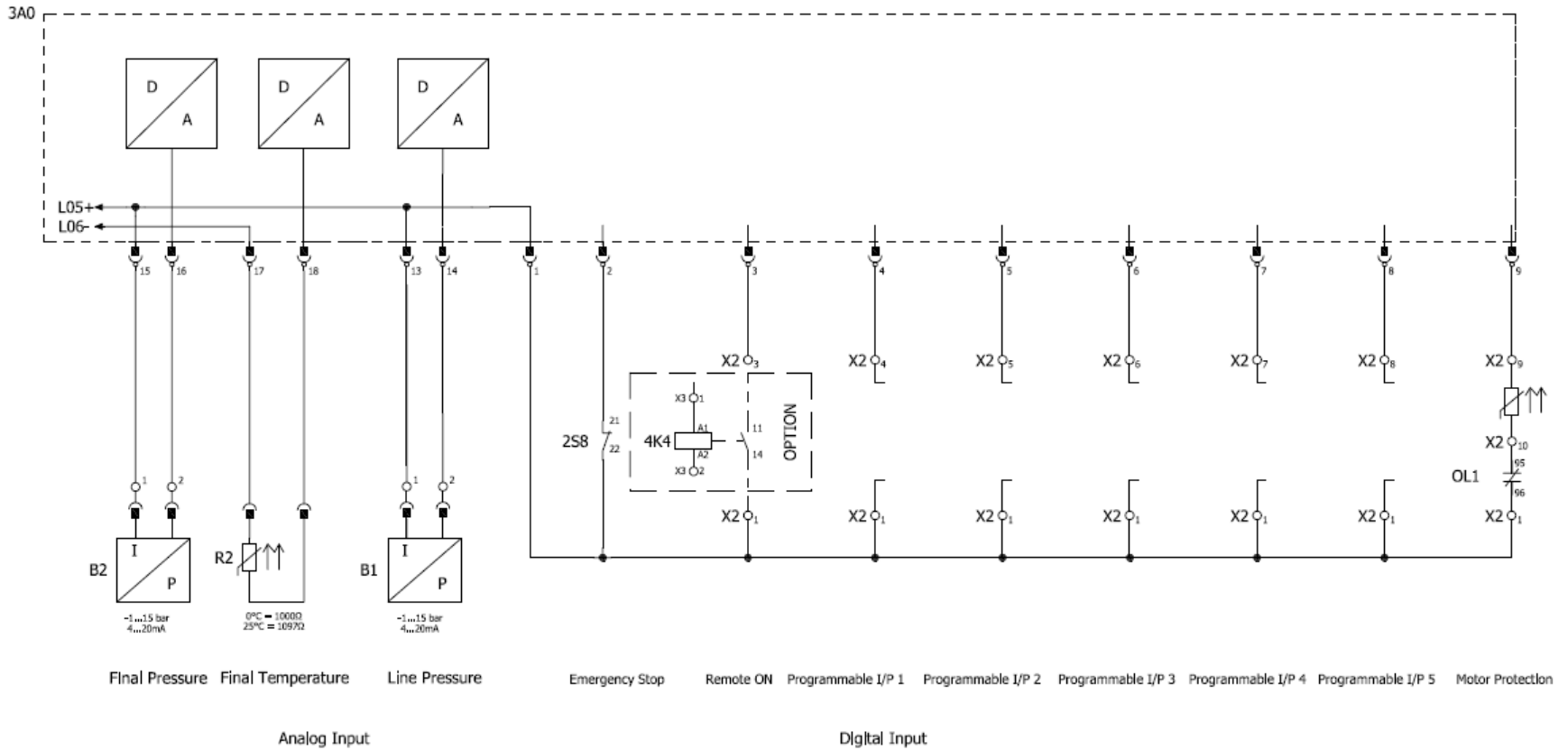

304ECC546 - 00  
 (Ref. Drawing)  
 Page 3 of 3

Figure 4- 6 -- WIRING DIAGRAM, FIXED SPEED -TRI-VOLTAGE- 200-230/460v 60Hz

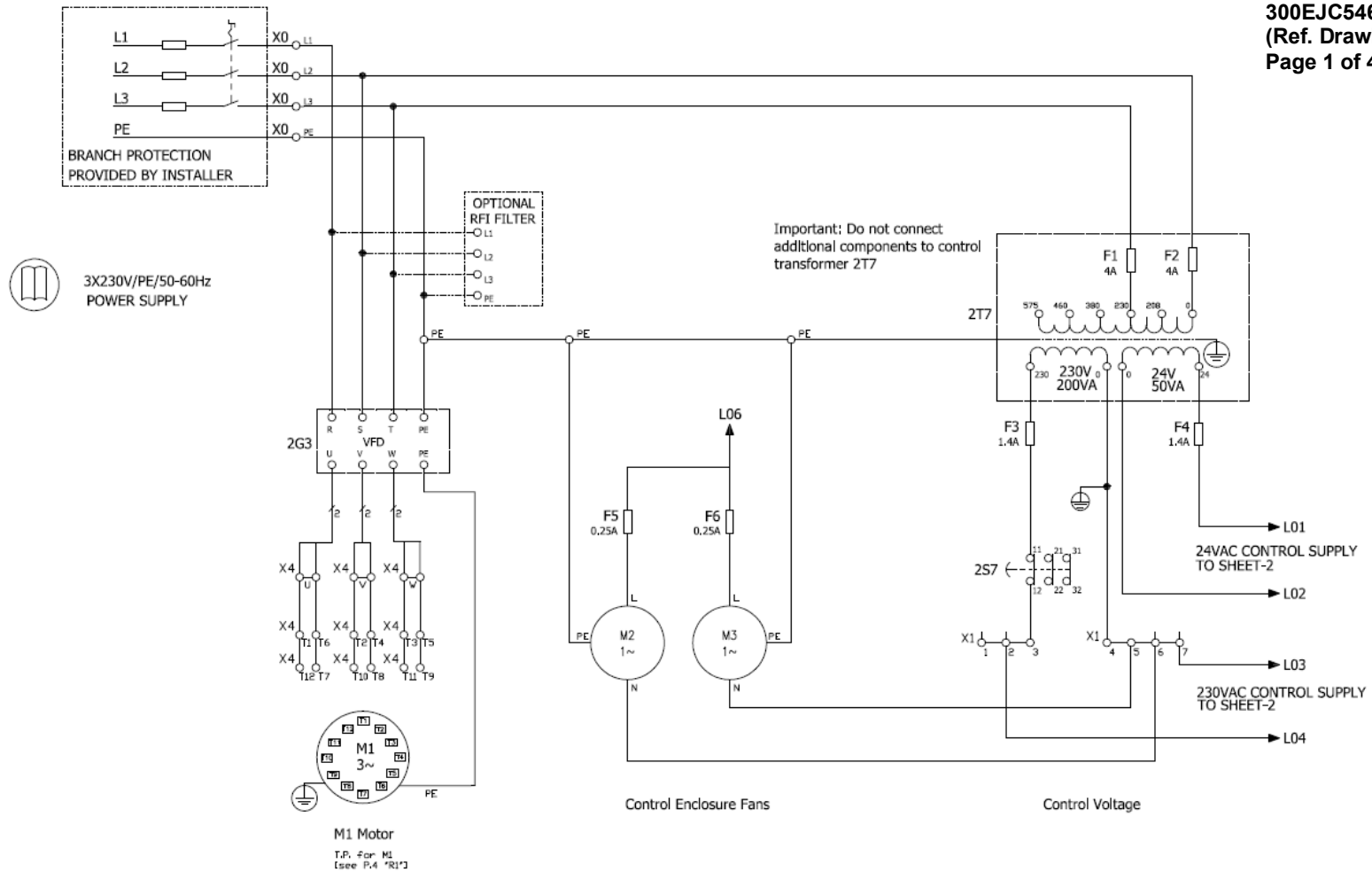

MOTOR LEAD NAMING TRANSLATION											
T1	<b>T2</b>	T3	T4	T5	T6	T7	T8	T9	T10	T11	T12
U1	V1	W1	U2	V2	W2	U3	V3	W3	U4	V4	W4

FIGURE 4- 7 – WIRING DIAGRAM, VARIABLE SPEED – 230v-60Hz

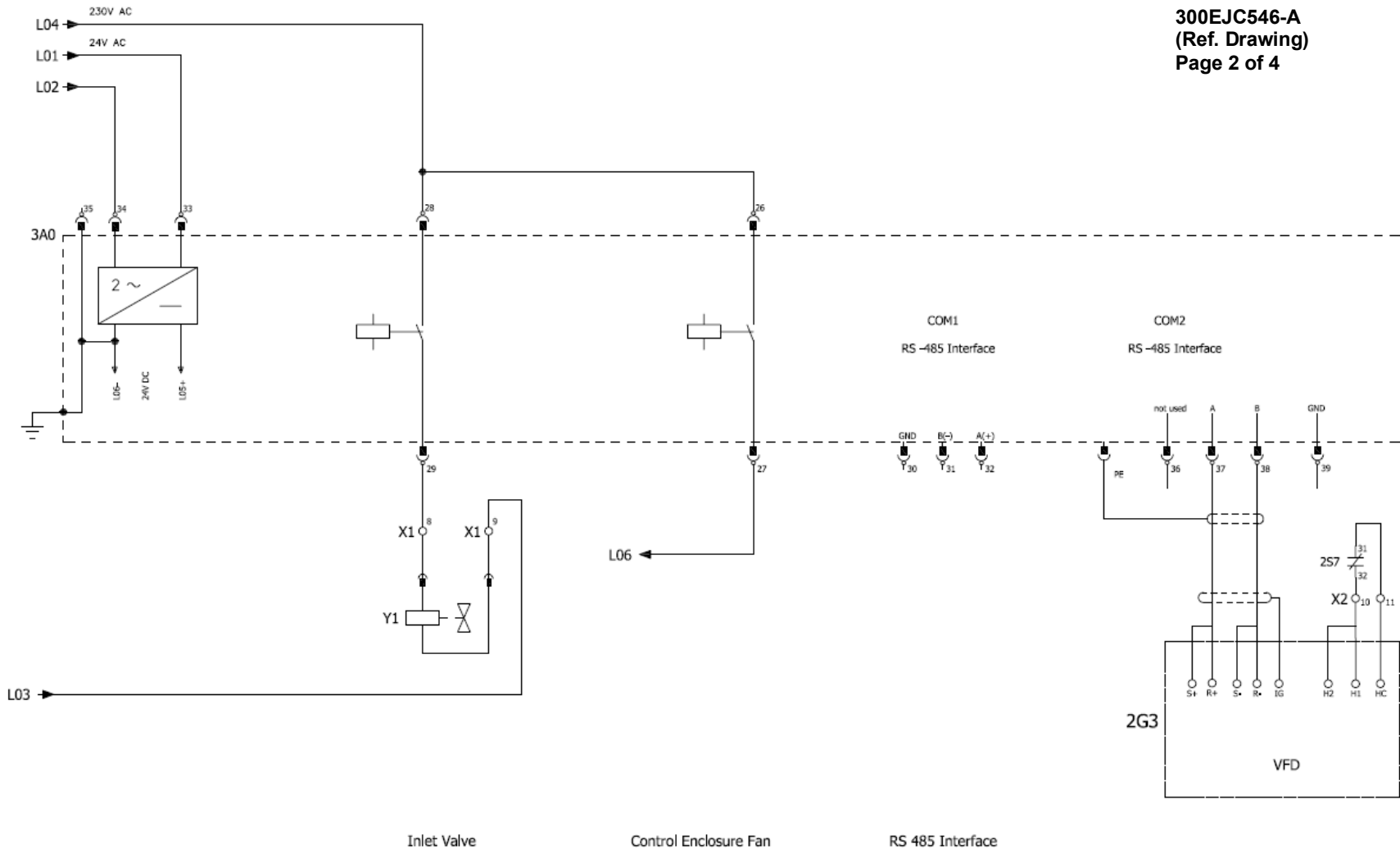
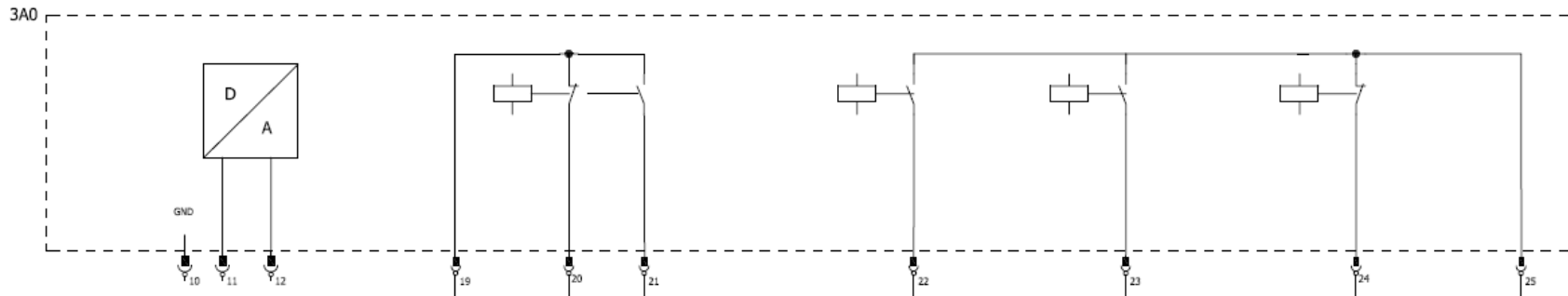

Figure 4-7 – WIRING DIAGRAM, VARIABLE SPEED – 230v-60Hz



307ECA546  
(Ref. Drawing)  
Page 2 of 3

----- Output                      Programmable Output 1                      Programmable Output 2                      Programmable Output 3                      Programmable Output 4

Figure 4-7 – WIRING DIAGRAM, VARIABLE SPEED – 230v-60Hz

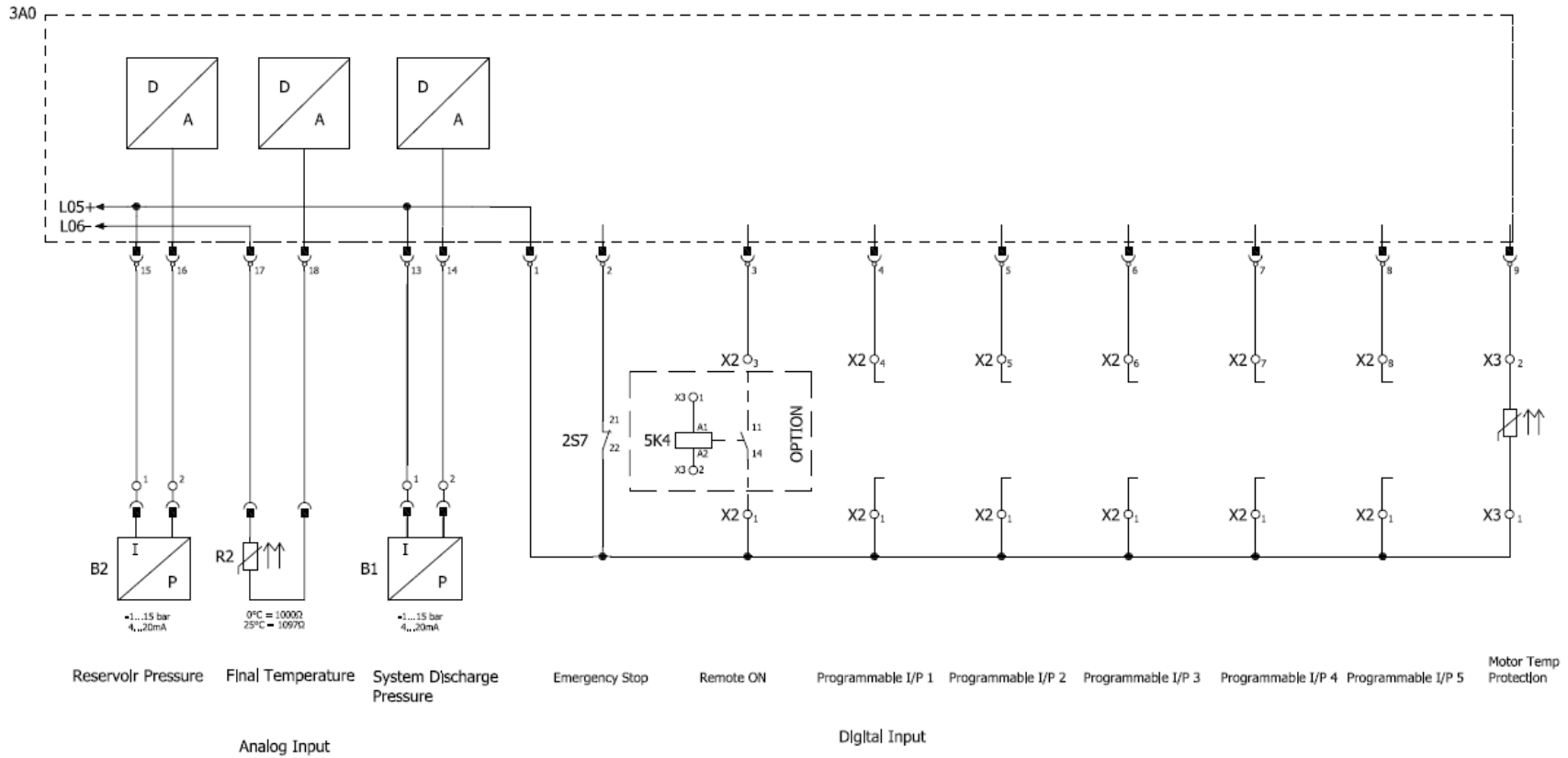
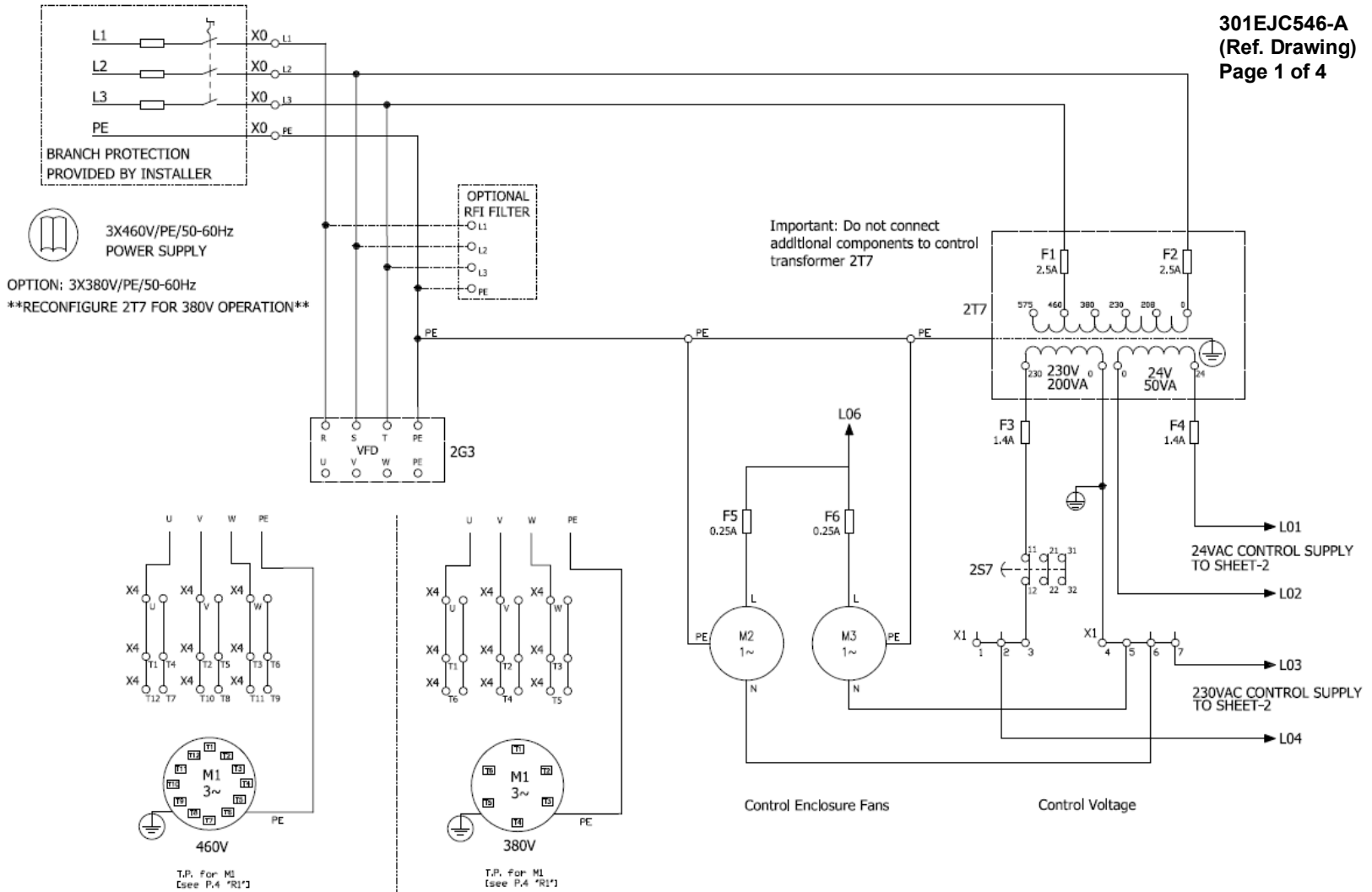

Figure 4-7 – WIRING DIAGRAM, VARIABLE SPEED – 230v-60Hz



**460V MOTOR LEAD NAMING TRANSLATION**

T1	<b>T2</b>	T3	T4	T5	T6	T7	T8	T9	T10	T11	T12
U1	V1	W1	U2	V2	W2	U3	V3	W3	U4	V4	W4

**380V MOTOR LEAD NAMING TRANSLATION**

T1	<b>T2</b>	T3	T4	T5	T6
U1	V1	W1	U2	V2	W2

FIGURE 4- 8 – WIRING DIAGRAM, VARIABLE SPEED – 380/460v-60Hz

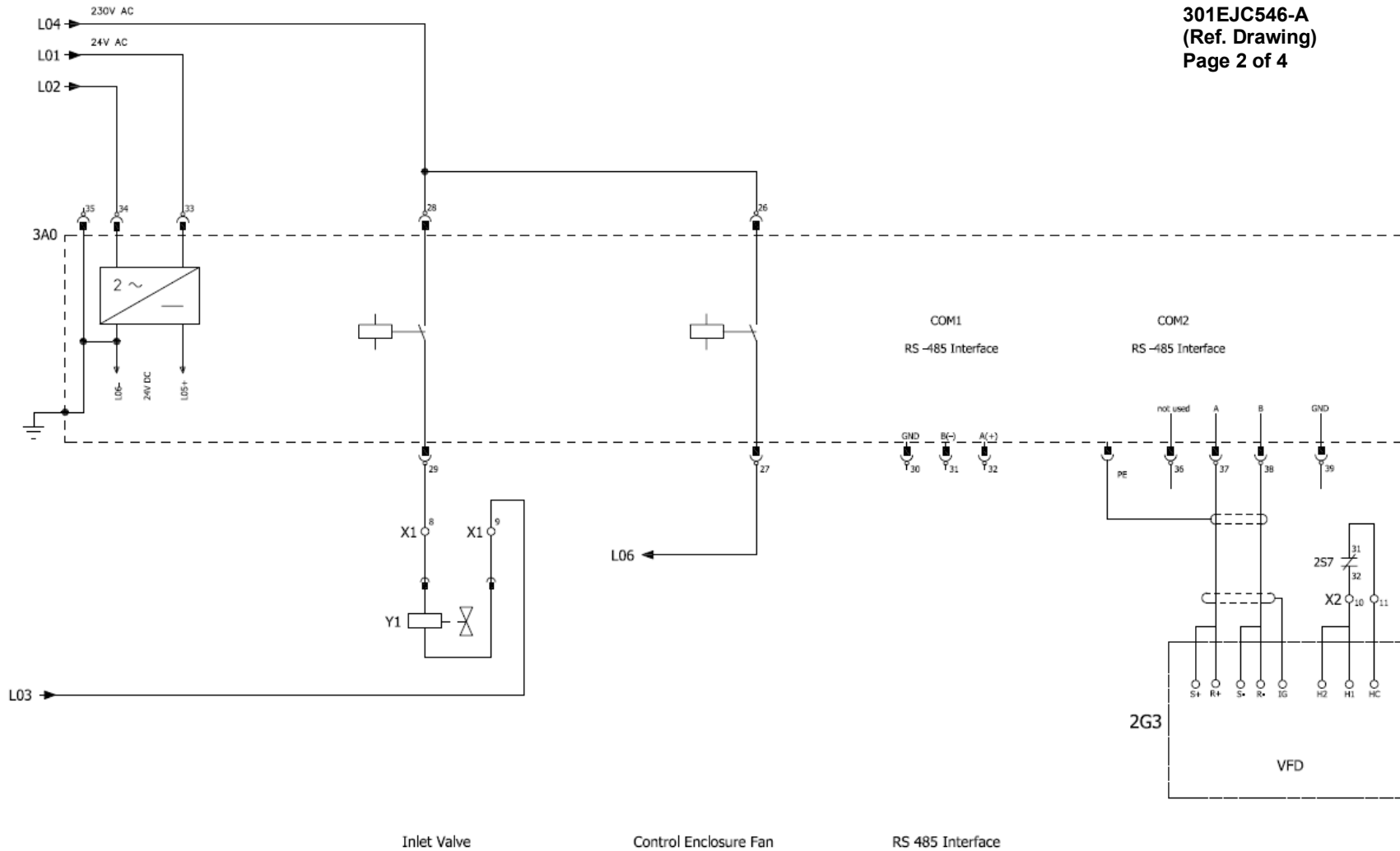

Figure 4-8 – WIRING DIAGRAM, VARIABLE SPEED – 380/460v-60Hz

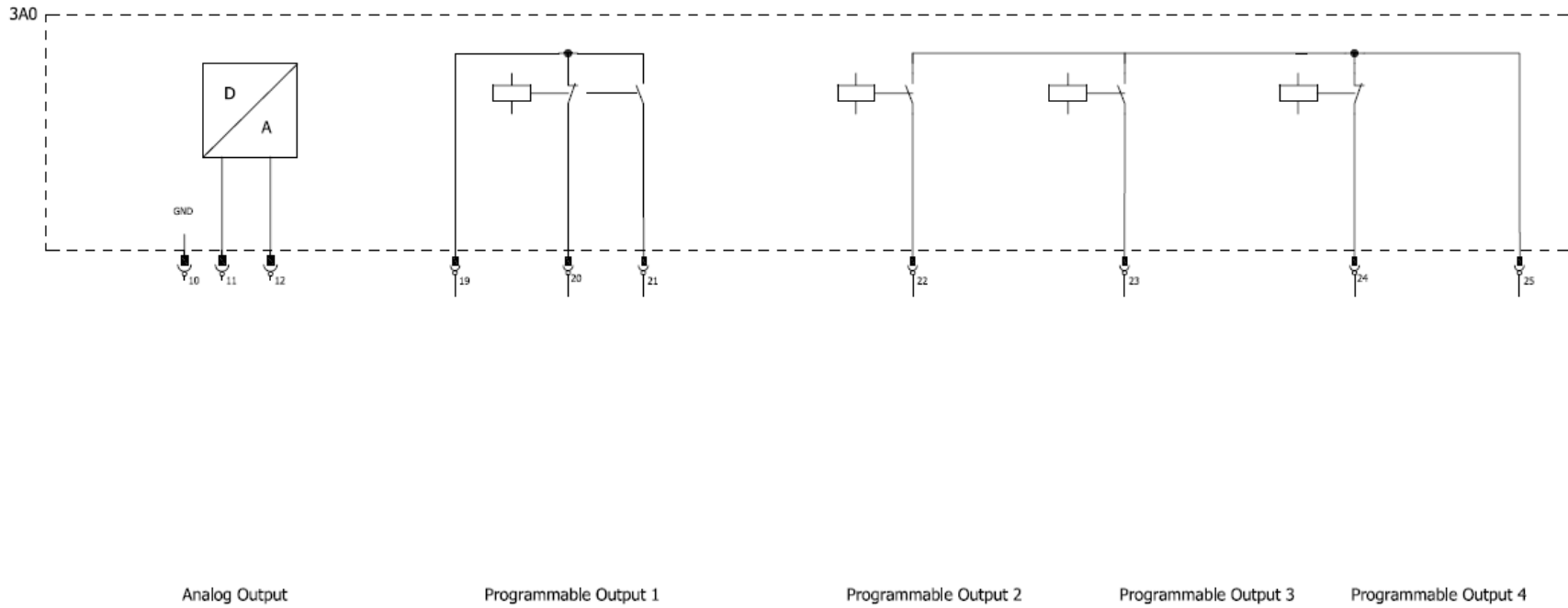

Figure 4-8 – WIRING DIAGRAM, VARIABLE SPEED – 380/460v-60Hz



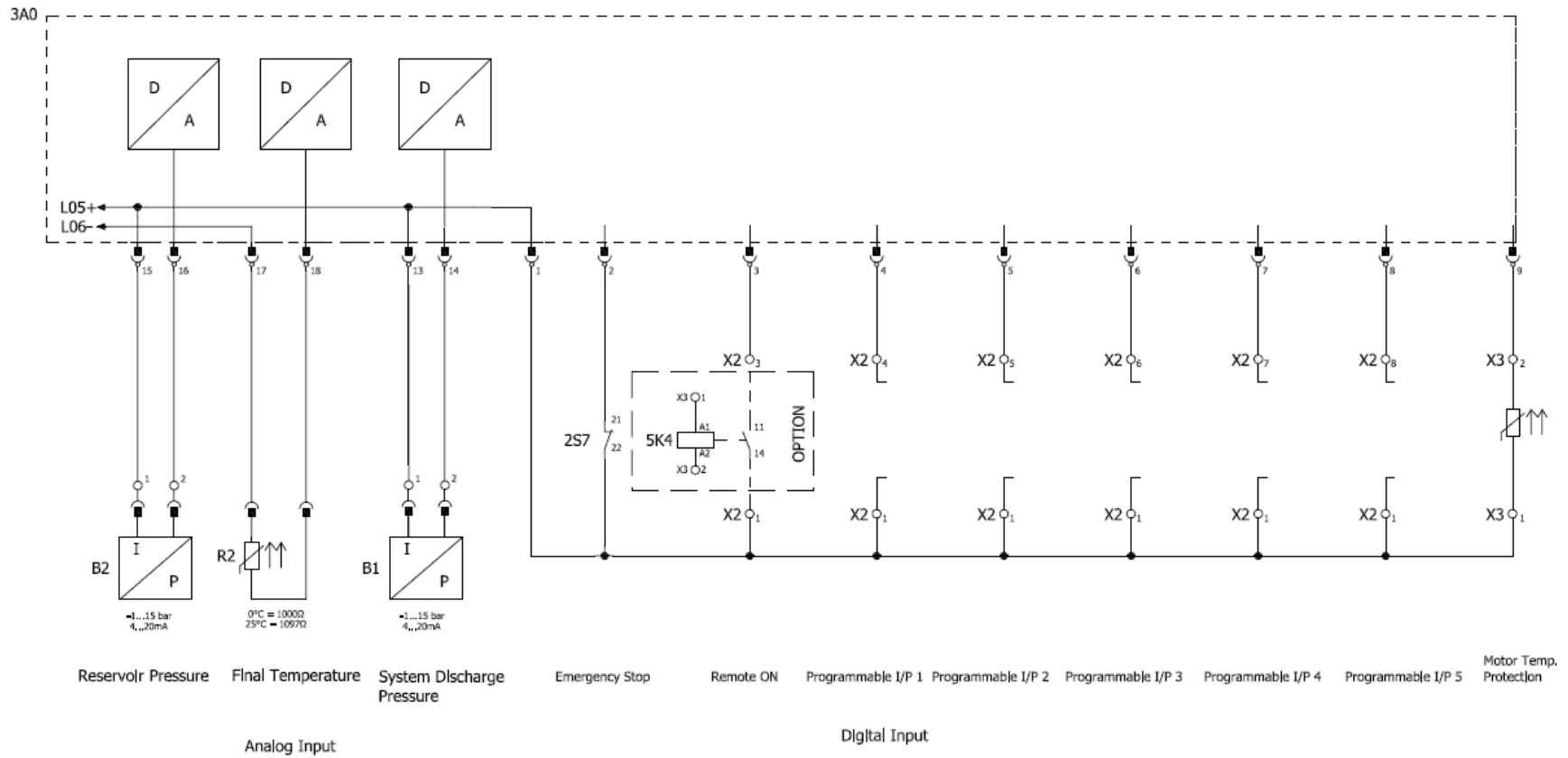

Figure 4-8 – WIRING DIAGRAM, VARIABLE SPEED – 380/460v-60Hz

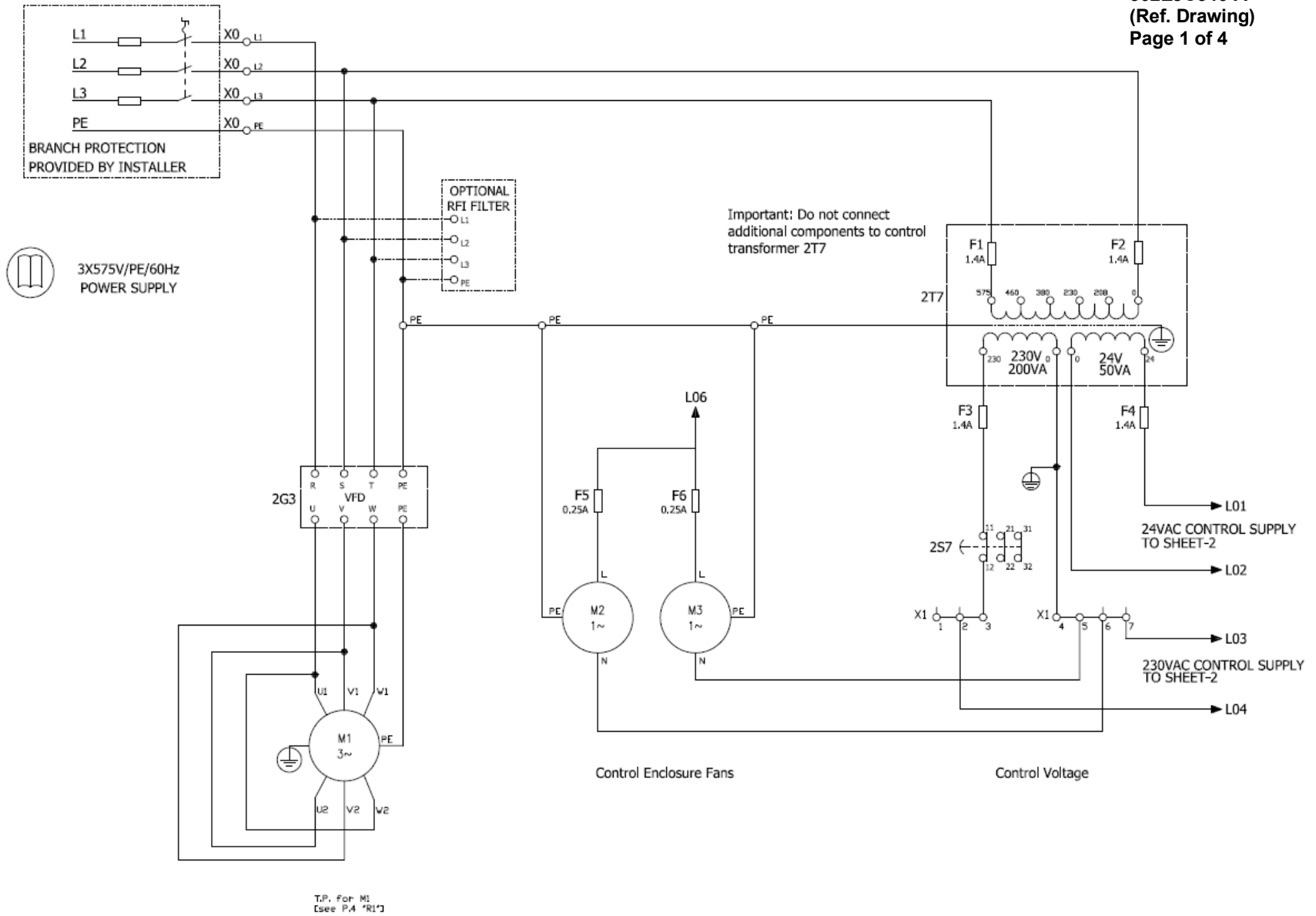

FIGURE 4- 9 – WIRING DIAGRAM, VARIABLE SPEED – 575v -60Hz

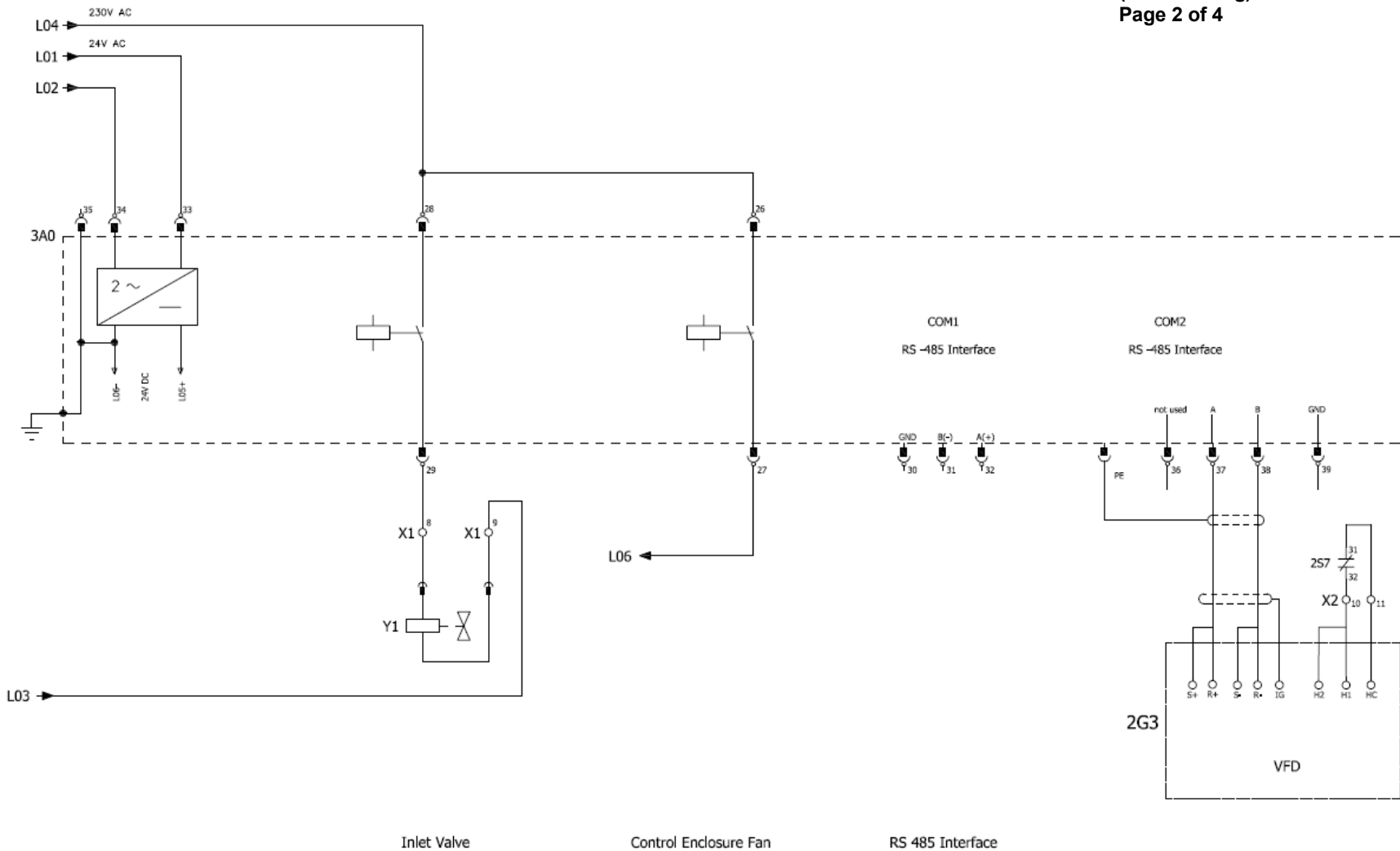

Figure 4-9 – WIRING DIAGRAM, VARIABLE SPEED – 575v -60Hz



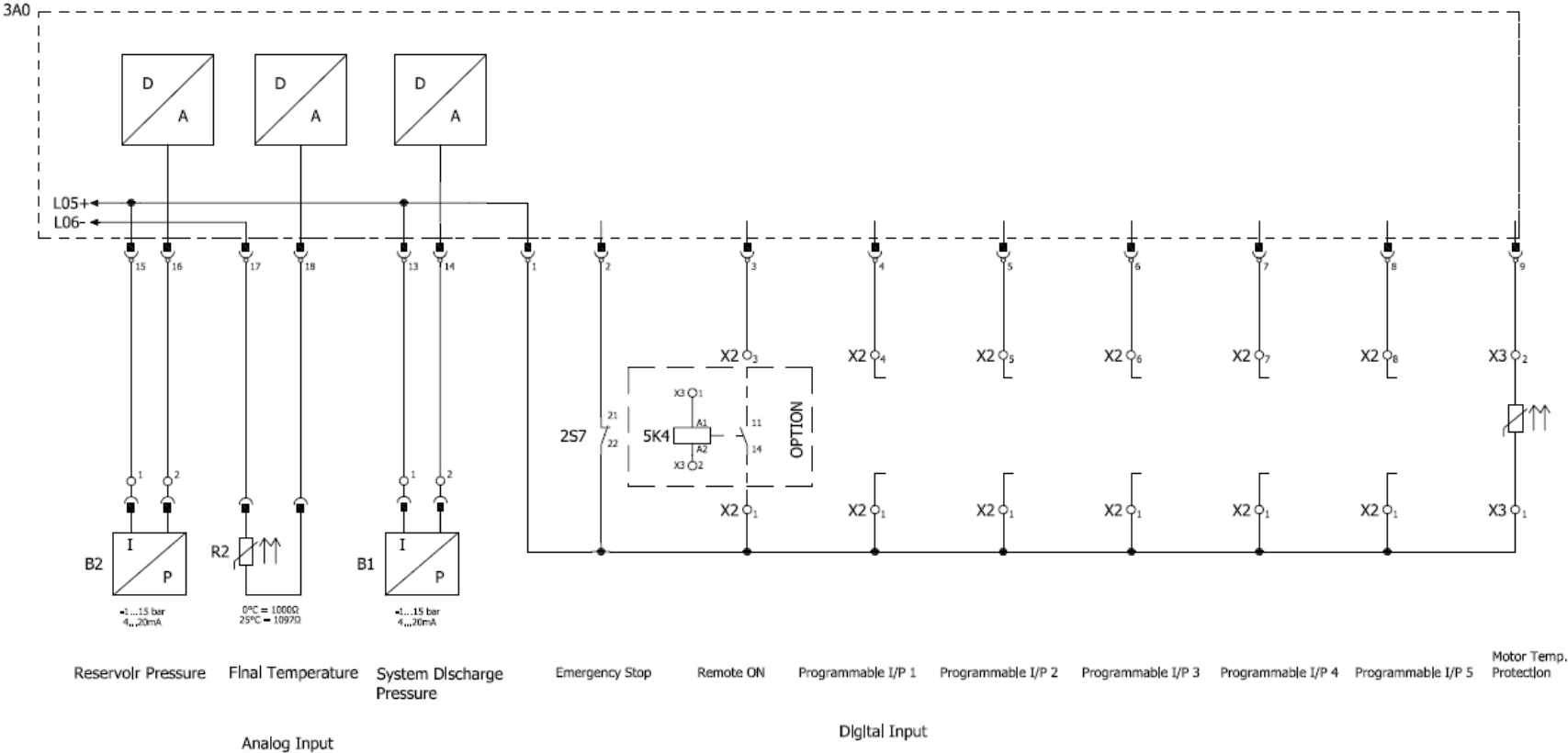

Figure 4-9 – WIRING DIAGRAM, VARIABLE SPEED – 575v -60Hz

**MISCELLANEOUS CONTROL DEVICES** - Refer to Figure 4-8 for the schematic diagram of the control system.

**Air Inlet Filter (1)** - Captures solid impurities in the air stream entering compressor inlet. It also attenuates noise emitted by the compressor inlet.

**Intake Regulator Assembly (2)** - This device controls the intake of atmospheric air entering the compressor during the Load/Unload phases of operation.

- During the loaded state: The **inlet poppet (pressure control valve 2.2)** remains open and allows atmospheric air to enter the compressor inlet.
- During the unloaded state: The **2-way solenoid valve (Y1)** feeds pressurized air underneath the **piston (actuating cylinder 2.1)**, forcing it and the **inlet poppet (2.2)** upward and blocking-off the compressor intake. Excess gas is vented to atmosphere. A small purge line (**non-return valve 2.3**) allows a stream of air to reach the rotors and keep them from unstable, noisy operation and producing sufficient pressure to maintain cooling / lubricating oil flow.

**Electric Motor (3)** – Drives the **compressor (4)** via a **belt drive assembly (5)**, and drives the package ventilation fan from a secondary rear shaft. It is energized by the Wye/Delta starter (variable frequency drive in variable speed models), which in turn is controlled by the GD Pilot controller.

**Pressure Reservoir (6)** – Separates by inertial effects the bulk of the compressed air and injection oil streams and serves as a sump for the latter.

**Fine Air/oil separator (7)** - Intercepts and coalesces the aerosol oil stream in the compressed air exiting the inertial separation process within the reservoir.

**Oil Filler Cap (8)** – Oil fill port on the reservoir.

**Oil drain (9)** . Ball valve drains the oil from the reservoir and the oil trapped in the oil cooler and associated hoses.

**Oil Level Indicator (10)** - This gauge is located on the oil reservoir and indicates the oil level. See Oil Level Gauge on Section 5 for more details.

**Oil Filter (11)** - Captures solid impurities in the oil entering the compressor injection port.

**Oil Cooler (12)** – The air-cooled heat exchanger removes heat from the oil stream prior to injection.

**Pressure Relief Valve (13)** . This device protects the pressure containing components of the compressor package against high pressure exceeding 217 psig. See Section 9, for maintenance information.

**Minimum Discharge Pressure/Check Valve (14)** - This device maintains minimum pressure (65psig) within the air/oil sump, thus ensuring adequate lubricating oil injection flow to the compressor even when no air delivery into the system is taking place. It also functions as a check valve to prevent reversed air flow from the system line during compressor stoppage. See Section 9 for maintenance information.

**Air cooler (15)** – The air-cooled heat exchanger removes heat from the air stream prior to exit from the package.

**Oil fine separator extractor (16)** – This annular orifice, built into the air/oil separator element adaptor pipe, controls the amount of oil and compressed air that is returned from the air/oil separator back into the compressor.

**Solenoid Valve (Y1)** - This 2-way valve controls the position of the inlet valve in response to signals from the GD Pilot Controller.

**Pressure Sensor - Sump Dry Side (B1)** - This device is connected after the minimum pressure valve. It converts the pressure in the plant air system into an electrical signal for use by the GD Pilot controller for monitoring and control load/unload operation.

**Pressure Sensor - Sump Wet Side (B2)** - This device is connected to the oil sump. It converts the pressure in the oil sump into an electrical signal for use by the GD Pilot controller for monitoring and control. Its signal, when compared to that of sensor (B1), indicates the pressure loss across the air/oil separator element and it can also trigger a shutdown event in case an exceedingly high pressure is detected.

**Temperature Sensor - Sump Wet Side (R2)** - This device is connected to the oil sump. It converts the temperature in the oil sump into an electrical signal for use by the GD Pilot controller for monitoring and control. Its signal is used to monitor compressor temperature and also trigger a shutdown event in case an exceedingly high is detected.

The following items additional are provided with the Total System variant:

**Receiver** – Provides storage of compressed air and serves as a support for the compressor unit and optional dryer.

**Refrigerated dryer** – The [optional] electric refrigerated dryer cools and lowers the dew point of the compressed air stream delivered by the compressor unit by removing the condensed water vapor entrained.

**Dryer bypass valve** – These [optional] valves allow the isolation of the refrigerated dryer (from the compressed air line) for troubleshooting or maintenance purposes.

**Condensate drain valve** – This device provides drainage from the receiver. It, along with the receiver, replaces the water separator shipped loose with the basic package.

**Pressure relief valve** – This device protects the pressure containing components included with the received against high pressure exceeding 195.5 psig. Section 9 for maintenance information.

**Pressure gauge** – This device monitors the compressed air pressure within the receiver.

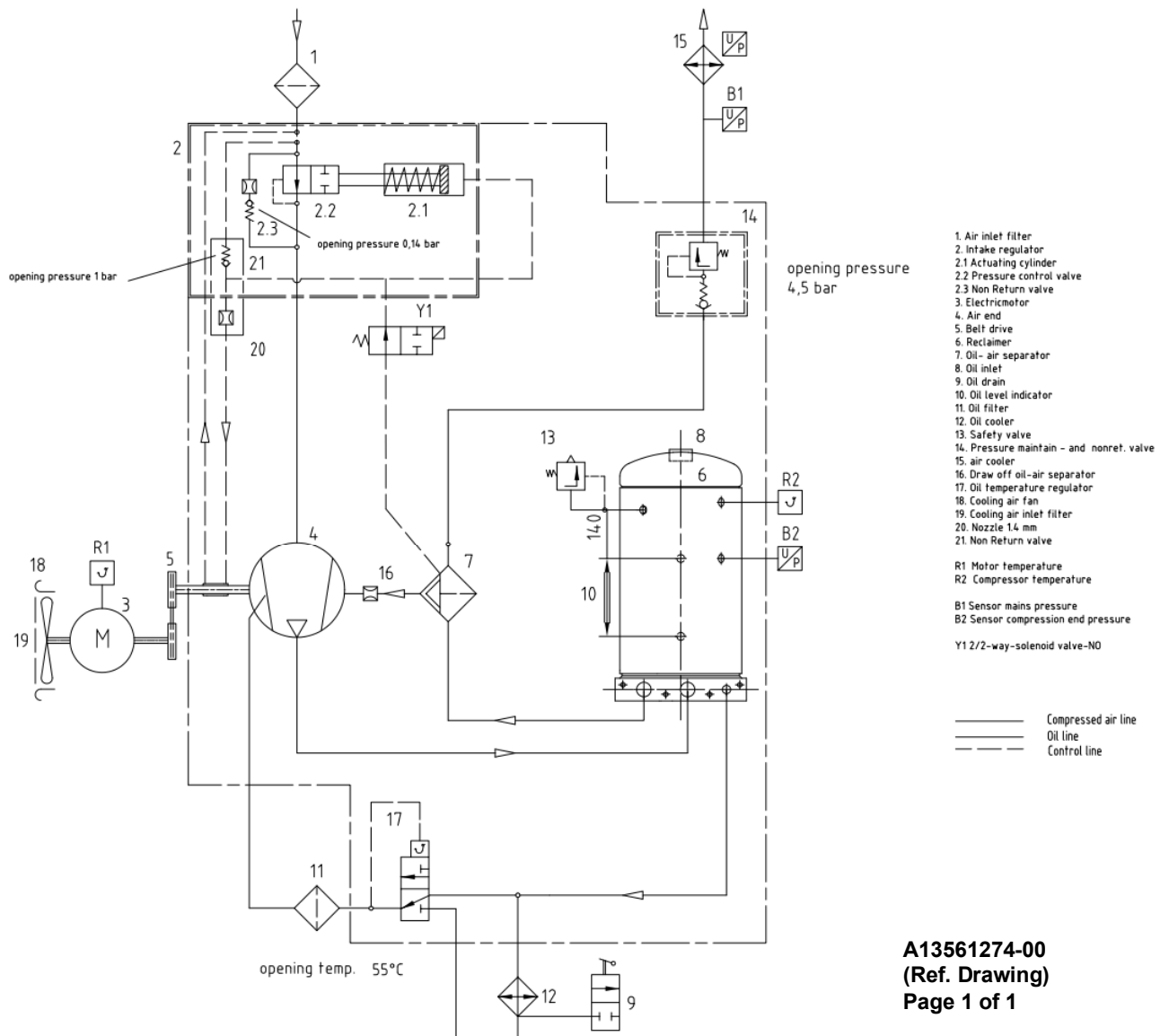

**FIGURE 4- 10 – PIPING AND INSTRUMENTATION ILLUSTRATION**



## SECTION 5

### LUBRICATION

#### OIL COOLER, OIL FILTER & SEPARATOR

---

**COMPRESSOR OIL SYSTEM** - Lubricating oil is employed to absorb the heat of compression, lubricate moving parts and seal internal clearances between the rotor and the air cylinder. Pressure differential between the air/oil sump and the final injection point into the compressor is used to move the oil mass through the various oil system components. Refer to Figure 4-8 for the arrangement of the oil system components - they are highlighted in blue for identification ease.

Oil exits the air/oil sump and is delivered to the heat exchange and thermal mixing valve, where cold (oil cooler branch) and hot (oil bypass branch) are mixed to the desired compressor injection temperature. The tempered oil is cleansed via the oil filter before injection into the compressor casing.

**RECOMMENDED LUBRICANT** - Champion compressors is factory filled with one of several Champion RotorLub lubricants. These lubricants are formulated to the highest quality standards and are factory authorized, tested and approved for use in rotary screw compressors. RotorLub lubricants are available through your authorized Champion compressor distributor.

**OIL SPECIFICATIONS** - The standard factory fill compressor lubricant is Champion RotorLub 4000, a superior semi-synthetic blend of petroleum stock and various protective additives, suitable for year-round operation. For exceedingly high or low operating temperatures, see lubricant recommendations in this and in Section 2.

**OIL LEVEL INDICATOR (GAUGE)** indicates the amount of oil in the oil reservoir - See Fig 5-1 for details. Read oil level when unit is shut off and the foam has settled out. In operation the oil level will fluctuate as the compressor loads and unloads. Adequate oil level falls between the MAX and MIN limits of the sight glass:

- The approximate oil system total capacity is 2.5 Gals (9.5 L)

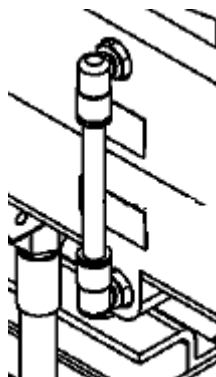

**FIGURE 5- 1 – Oil Level Sight Glass**

Before draining, adding, or changing the lubricant oil in the compressor, be aware of the following hazards associated with these tasks:

 **DANGER**



Air/oil under pressure will cause severe personal injury or death. Shut down compressor, relieve system of all pressure, disconnect, lockout and tagout power supply to the starter before removing valves, caps, plugs, fittings, bolts and filters.

 **CAUTION**

Compressor, air/oil reservoir, separator chamber and all piping and tubing may be at high temperature during and after operation.

 **CAUTION**

Use of improper lubricants will cause damage to equipment. Do not mix different types of lubricants or use inferior lubricants.

 **CAUTION**

Improper equipment maintenance with use of synthetic lubricants will damage equipment. Oil filter and oil separator change intervals remain the same as for RotorLub 4000 – See “Maintenance Schedule”, page 83.

 **CAUTION**

High temperature operation can cause damage to equipment or personal injury. Do not repeatedly restart the unit after high temperature stops operation. Find and correct the malfunction before resuming operation.

 **CAUTION**

Read the oil level when the unit is shut off for an accurate measurement.



**All materials used in Champion compressor units are compatible with RotorLub 8000 Lubricant. Use caution when selecting downstream components such as air line lubricating bowls, gaskets and valve trim.**

**RotorLub 8000 Synthetic Lubricant is not compatible with low nitrile Buna N or acrylic paints. RotorLub 8000 is compatible with most air system downstream components.**

Safety Sheets (SDS) are available for all RotoLub lubricants at web address.

<http://www.gardnerdenver.com/champion/download-center/>

**LUBRICANT CHANGE PROCEDURE** - If upgrading to a different lubricant type (e.g., longer life, higher temperature, food grade, etc.), following the proceeding steps - see Figure 1-3 for hardware details:

1. Be sure the unit is completely off and that no air pressure is in the oil reservoir.
2. Disconnect, tag and lockout the power supply to the starter.
3. Thoroughly drain oil system while hot:
  - Remove the plug and open the drain valve at the lower left hand side of the oil core tank. Once the oil has been drained, close the drain valve and reinstall the plug.
  - Remove and drain oil from the oil filter. Reinstall the used filter.
4. Fill the system with a 50 percent charge of the new lubricant:
  - Start the machine and monitor its operation.
  - Allow the machine to reach a stable discharge temperature (5-7min), then shut down.
5. Thoroughly drain oil system.
6. Replace used oil filter and air/oil separator element with new ones.
7. Fill the system with a full charge of the new lubricant.
8. Machine should then be run normally; however, total run time after the initial change-out should be 50 percent of normal anticipated service life of the new lubricant.
  - Drain all lubricant from the system, change the filter and separator, and replace with a full charge of the new lubricant.
9. Subsequent lubricant change-outs should be at normal intervals. See %Oil Change Interval+in this Section for details.

**COLD AMBIENT OPERATION** - See %Installation for Cold Weather Operation+, Section 2.

**ADDITION OF OIL BETWEEN CHANGES** must be made when the oil level is below the minimum level of the sight glass as read while the unit is completely off and blown down, and the foam has settled out.

1. Be sure the unit is completely off and that no air pressure is in the oil reservoir.
2. Disconnect, lockout and tagout the power supply to the starter.
3. Wipe away all dirt around the oil filler plug located on top of the oil sump.
4. Remove the oil filler plug and add oil as required to return the oil level to the middle of the sight gauge.
5. Install oil filler plug, run and check for leaks.

DO NOT OVERFILL (you should see oil slightly above the full line after running fully loaded and then shutting down the machine and allowing the foam to settle out). The quantity required to raise the oil level from **ADD** to **FULL** is shown on Figure 5-1. Repeated addition of oil between oil changes may indicate excessive oil carry-over and should be investigated.



**Excessive oil carry-over can damage equipment. Never fill oil reservoir above the “FULL” marker.**

**OIL CHANGE INTERVAL** - Recommended oil change intervals are based on oil temperature - see Figure 5-2 for typical trends for the standard lubricant (RotorLub 4000) and a synthetic lubricant (RotorLub 8000). Consult GD for additional lubricant types available for your compressor.

When operating conditions are severe (very dusty, high humidity, etc.), it will be necessary to change the oil more frequently. Operating conditions and the appearance of the drained oil must be surveyed and the oil change intervals planned accordingly by the user. Champion offers a free oil analysis program with the RotorLub lubricants, and we recommend a sample be sent in at 100 hours on a new unit.

Discharge Temperature	RotorLub 4000 Change Interval	RotorLub 8000 Change Interval
Up to 180° F (82° C)	4000 hrs.	8000 hrs.
180° to 190° F (82° C to 88° C)	3000 hrs.	6000 hrs.
190° to 200° F (88° C to 93° C)	2000 hrs.	4000 hrs.
200° F+ (93° C)	1000 hrs.	2000 hrs.

**FIGURE 5- 2 – Oil Change Interval**

**DRAINING AND REFILLING THE OIL SYSTEM** - Always drain the complete system. Draining when the oil is hot will help to prevent varnish deposits and carry away impurities . see Figure 1-3 for hardware details.

1. Be sure the unit is completely off and that no air pressure is in the oil reservoir.

2. Disconnect, lockout and tagout the power supply to the starter.
3. Thoroughly drain oil system while system is hot:
  - Remove the plug and open the drain valve at the lower left hand side of the oil core tank. Once the oil has been drained, close the drain valve and reinstall the plug. Make sure to provide a suitable pan to catch the 2.5 gal. (9.5 l) oil charge.
  - If the drained oil and/or oil filter element is contaminated, discontinue this procedure and follow instead the "Lubricant Change Procedure" in this Section.
4. Replace both used oil filter and air/oil separator element with new ones.
  - Remove each spin-on element.
  - Clean each gasket face of the filter body.
  - Coat each new element gasket with clean lubricant used in the unit
  - Screw each new element on the filter body and tighten by hand. Tighten 1/2 turn more after gasket makes contact. **DO NOT OVERTIGHTEN ELEMENT.**
5. Wipe away all dirt around the oil filler plug.
6. Remove the oil filler plug and add oil as required to return the oil level to the full marker on the gauge.
7. Install the oil filler plug and operate the unit for about a minute allowing oil to fill all areas of the system. Check for leaks.
8. Shut down unit, allowing the oil to settle, and be certain all pressure is relieved.
9. Add oil, if necessary, to bring level to **5/8 FULL.**

Use only CLEAN containers and funnels so no dirt enters the reservoir. Provide for clean storage of oils. Changing the oil will be of little benefit if done in a careless manner.



**Use only the replacement element shown on the filter tag or refer to the parts list for the part number.**



**Excessive oil carry-over can damage equipment. Never fill oil reservoir above the "FULL" marker.**



**Improper oil filter maintenance will cause damage to equipment. Replace filter element every 1000 hours of operation. More frequent replacement could be required depending on operating conditions. A filter element left in service too long may damage equipment**

**MOISTURE IN THE OIL SYSTEM** – During periods of low ambient temperatures, light duty cycles, high humidity, or in the event of thermal mixing valve malfunction, the oil charge residing in the sump may not reach a high enough temperature to keep water vapor from condensing as liquid water, a condition that contaminates the oil charge, may cause excessive oil carryover, or result in compressor failure.

To help the end user determine if the compressor package is operating under potential water condensing conditions, the charts in Fig 5-3 and 5-4 have been provided. To use, find the prevailing ambient temperature along the horizontal scale of the chart, move vertically from this point until intercepting the slanted line corresponding to the operating discharge pressure; and finally, move horizontally from this point to read the corresponding water vapor dew point on the vertical scale. The compressor discharge temperature must be maintained at a minimum of 10° F (5.5° C) above this dew-point temperature to prevent condensation accumulation in the lubricant reservoir. Note that the charts conservatively assume 100% relative humidity for the ambient air.

The presence of water in the oil may be identified by one of the following means:

- Oil drawn from the oil sampling valve attached to the sump (see Fig 1-3).
- Oil volume drained during an oil exchange.
- Periodic (e.g., every 2000hrs) oil sample analyzed by a reputable laboratory.

If water is found in the oil, drain sufficient volume of oil until no visible water is found - the heavier water will collect at the low elevations of the oil system, thus it will likely be expelled first. If this condition persists, consider the following solutions to avoid water condensation in the compressor oil:

- Make sure that the correct setting for the thermostatic mixing valve element is used - value is stamped on valve body.
- If the standard thermostatic element (55°C/131°F) does not prevent water condensation, consult your application with Champion. The standard thermostatic element may be replaced with a high temperature one (70°C/158°F) and the oil charge changed (see "Lubricant Change Procedure in this section) with a high temperature one (RotorLub 8000TH). Depending on the prevailing ambient temperature, the controller setting for the high discharge temperature shutdown may have to be reset to 240°F also.

**THERMOSTATIC MIXING VALVE.** This device, housed within the compressor body, mixes hot and cooled oil and delivers a tempered mixture to the oil filter and finally the compressor injection port - see Fig 1-3 for its location.

Its thermostatic element expands with heat . it will stroke from just opening to fully open state within a 27°F (15°C) temperature change. Within these two temperature limits the valve gradually mixes hot separator oil with cooled heat exchanger oil to maintain a nearly constant oil injection temperature. Above this range of oil temperature, the valve blocks all hot oil and only cooled oil is delivered.

The valve's nominal setting is stamped on the valve body. It may be verified by immersing the valve assembly into an open container with lubricating oil, raising its temperature to its nominal setting and checking that the element strokes fully from closed to open.

#### **L15-22 Models**

- Standard valve opening temp = 131°F (55°C), fully open temp = 158°F (70°C)
- Optional valve opening temp = 158°F (70°C), fully open temp = 185°F (85°C)

#### **LRS15-22 Models**

- Standard valve opening temp = 158°F (70°C), fully open temp = 185°F (85°C)

**Optional Element.** If the compressor is used in a predominantly cold (<32°F, 0°C) and/or humid environment, proper oil viscosity and avoidance of water vapor condensation in the oil system may be achieved by using a higher setting (185°F, 85°C) thermostatic element. Consult Champion for details.

**OIL SUMP (RESERVOIR)** - This device provides the inertial separation of air and oil streams discharged by the compressor - the bulk (98%) of the air/oil separation is done at this step. It also serves as a holding and degassing volume for the major portion of the oil charge. It provides limited air storage for control and gauge actuation.

**AIR / OIL SEPARATOR** - This device provides the final (2%) of the air/oil separation - typically 2ppm oil content at the final discharge of the compressor package. It is housed in a removable spin-on cartridge.

Its high level of performance may be affected by the following conditions:

- Compromised media (e.g., ruptured).
- Contaminated media (e.g., varnish, moisture, inadequate oil type).
- High oil level in oil sump.
- Blockage of oil return orifice.
- Abnormally frequent or fast depressurization cycles.

Oil separator element life cannot be predicted; it will vary greatly depending on the conditions of operation, the quality of the oil used and the maintenance of the oil and air filters. The condition of the separator can be determined by pressure differential or by inspection.

**Separator Pressure Differential** - The pressure drop across the separator is equivalent to the difference between the two (2) pressure sensors in use. Use the measured pressure difference to forewarn of a potentially contaminated air-oil separator element:

- The pressure differential value may be calculated by subtracting the system pressure value from the compressor discharge pressure value.
- A pressure differential of 8psi may indicate a moderately dirty element.
- A pressure differential of 15psi may indicate a severely dirty element . replace ASAP.



**Using an oil separator element at excessive pressure differential can cause damage to equipment. Replace the separator when the pressure differential has reached 15psi.**

#### **OIL FILTER, AIR/OIL SEPARATOR ELEMENT INSPECTION PROCEDURE**

1. Remove the spin-on element.
2. Clean the gasket seating surface of the head.
3. Inspect the element internals by shining a light onto the media surface. If signs of contamination (dirt, rust, varnish, etc.) or damage is evident, replace the element.
4. Before reassembly, coat the element gasket with the same lubricant used in the unit.
5. Screw on until gasket makes contact. Hand tighten 1/3 to 1/2 turn extra.
6. Run the unit and check for leaks.

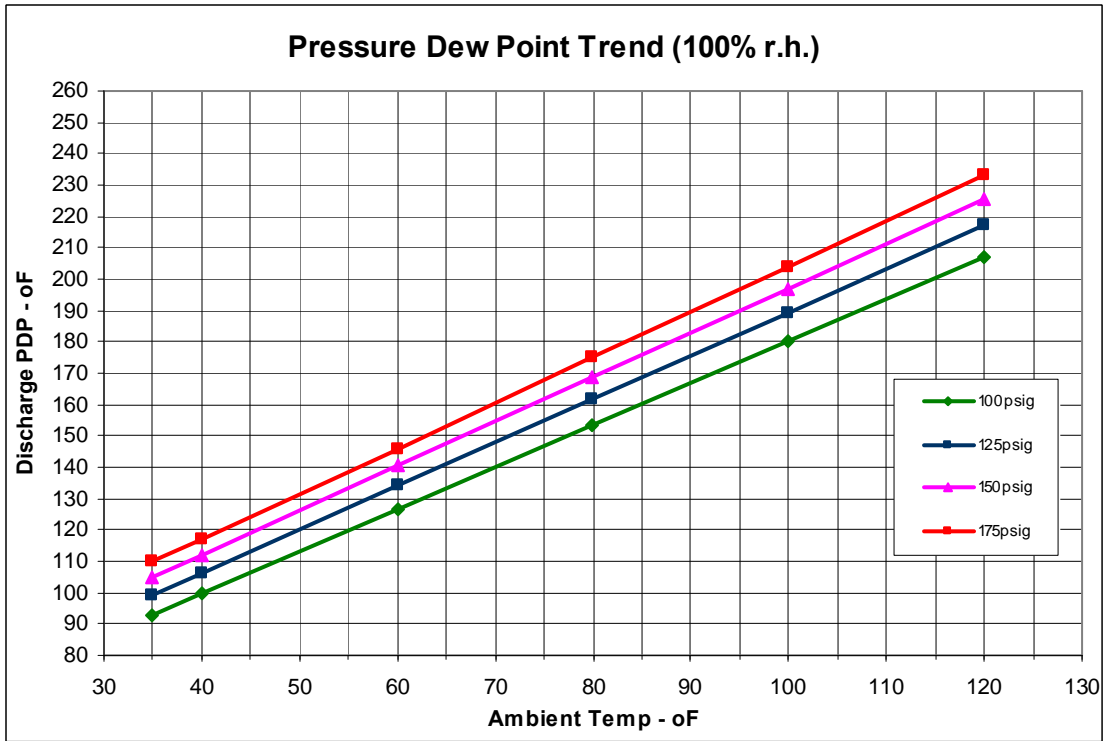

FIGURE 5- 3 – Dew Point Chart °F

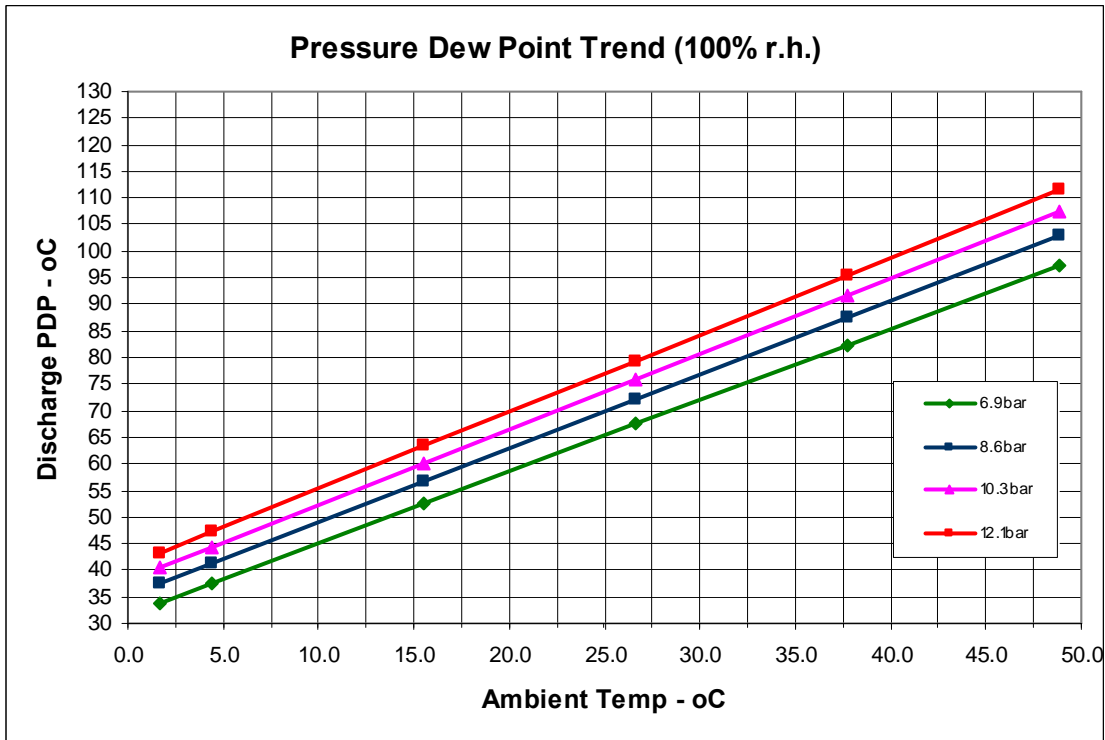

FIGURE 5- 4 – Dew Point Chart °C



## SECTION 6 HEAT EXCHANGERS (OIL/AIR)

---

**OIL/AIR HEAT EXCHANGERS** – The heat of compression absorbed by the oil injected into the compressors (for cooling and lubrication) is ultimately rejected in a convenient medium such as air - for these air-cooled cores. The compressor's main motor utilizes a shaft mounted fan to provide the cooling air for the heat exchanger.

**VENTILATION CONFIGURATION** . Air-cooled cores (radiator-type) are provided as standard feature. One (1) axial fan, located behind the fresh air inlet grille, delivers an air stream to: a) cool the exterior of the main electric motor and b) meet the cooling demands of the air/oil combination heat exchanger on its way out the package. The fan is mounted on a rear shaft of the main motor. In addition, an open-weave, non-metallic mesh media is held in place over the fresh air inlet grill to pre clean the cooling air stream.

Refer to Figure 6-1 for estimates of ventilation requirements. Please note that the air-cooled package requires the combined total of the heat exchanger plus the enclosure ventilation flow rates (which include motor ventilation and compressor intake). Furthermore, when package location makes it necessary to duct fresh cooling air in/out, these ducts must be sized with a maximum (total) pressure loss of 0.1 inch water gauge to avoid impacting the heat exchanger cooling air system. An external ventilation fan may be required to properly evacuate hot air from the compressor room.

<b>Minimum Cooling Air Flow Requirements</b>	
<b>L15 / L18 / L22</b>	<b>1942 CFM</b>
<b>L15RS / L18RS / L22RS</b>	<b>1659 CFM</b>

**FIGURE 6- 1 – Air Flow Chart**

**HEAT EXCHANGER MAINTENANCE** - All the required hardware, mechanical and electrical connections have been made at the Champion factory, thus the only regular maintenance required is to keep the exterior core fins free from dirt and other airborne debris per the following procedure:



**Compressor, air/oil sump and all piping and tubing may be at high temperature during and after operation.**



**Do not attempt inspection or cleaning of air-cooled heat exchangers until cooling fan has stopped rotating. Disconnect lockout and tag out package from power supply.**



**Air-cooled heat exchanger cores are fabricated from aluminum. Do not use caustic liquids to cleanse core or permanent damage will take place.**

1. Be sure the unit is completely off and that oil reservoir is depressurized.
2. Open and/or remove enclosure door panel adjacent the cooler assembly . See Figure 6-2 for details.
3. Inspect core area. If blocked with debris, use a moderate (e.g., 100psi) source of compressed air while directing nozzle (pointed to outer core finned surface) to dislodge debris and clean. Vacuum (applied from inner finned core surface) can also be employed to clean the surfaces.
4. Remove all loose debris from inner surfaces of the enclosure, including the main cooling fan area and its pre-filter, after cleaning process is complete.
5. Re-install the removed enclosure door panels.

**⚠ CAUTION**

The ventilation system for the air-cooled package relies on positive back pressure to cool the heat exchanger. Make sure that the enclosure panels that surround the heat exchanger area are closed during compressor operation, or the compressor discharge temperature will reach shutdown levels quickly.

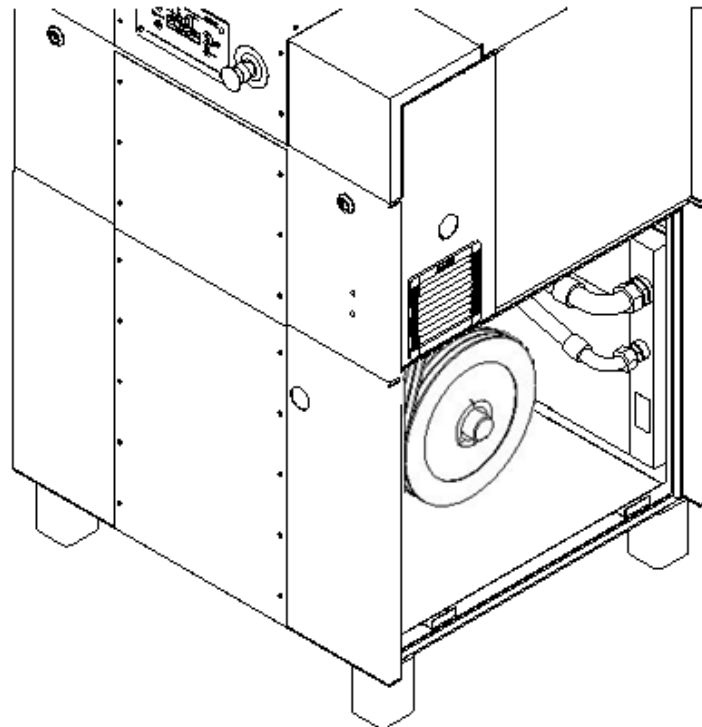

**FIGURE 6- 2 – Cooler Access**

## SECTION 7 AIR FILTERS

---

**COMPRESSOR AIR FILTER** - This device cleans the air stream entering the compressor inlet and is furnished as standard equipment on the compressor package. It is a single stage, high efficiency, cellulose media element housed in a non-corrosive housing.

Efficient compressor package operation depends on the unrestricted, clean supply of fresh air delivered by the air filter. In turn, the longevity of the filter element depends on the cleanliness of the local environment.

### NOTICE

**Use only genuine Champion air filter elements on Champion compressor units. Genuine parts are available through your authorized Champion distributor.**



**Do not oil this element. Do not wash in inflammable cleaning fluids. Do not use solvents other than water. Improper cleaning may damage the element.**



**Never operate the unit without the element. Never use elements that are damaged, ruptured or wet. Never use gaskets that won't seal. Keep spare elements and gaskets on hand to reduce downtime. Store elements in a protected area free from damage, dirt and moisture. Handle all parts with care.**

### FILTER ELEMENT INSPECTION AND/OR REPLACEMENT

1. Loosen and remove the fastening band (2) and remove the filter element (1) - see Figure 7-1 for details
2. Visually inspect the filter element (1). Replace it if:
  - Flaws (tears in media, damage to sealing surfaces) are evident.
  - Contamination (dirt, grease, etc.) is evident.
  - Recommended replacement period has been achieved . see Figure 11-1 for details.
3. Install the air filter element (1) and the fastening band (2) in the reverse order.

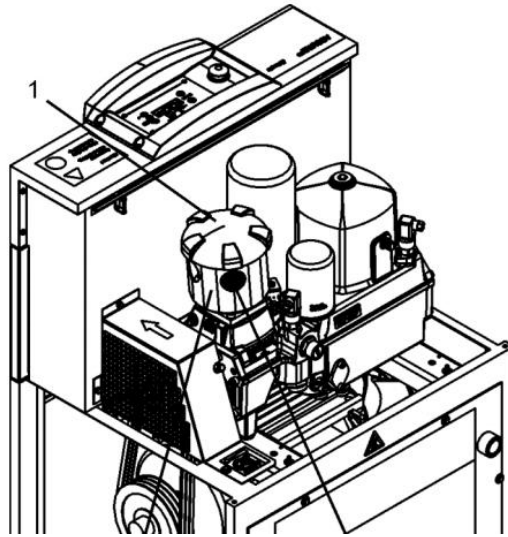

**FIGURE 7-1 – Compressor Air Filter**

#### **PACKAGE PRE-FILTER MAINTENANCE**

1. Remove the central screw and washer securing the pre-filter to the grill assembly and remove the pre-filter media (17). See Figure 7-2 for component details. Note: do not remove the fan grill.
2. Cleanse the pre-filter media with compressed air or with water to remove debris trapped in its fibers.
3. Replace the pre-filter media and central screw and washer in the reverse order.

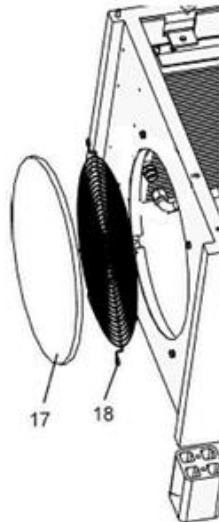
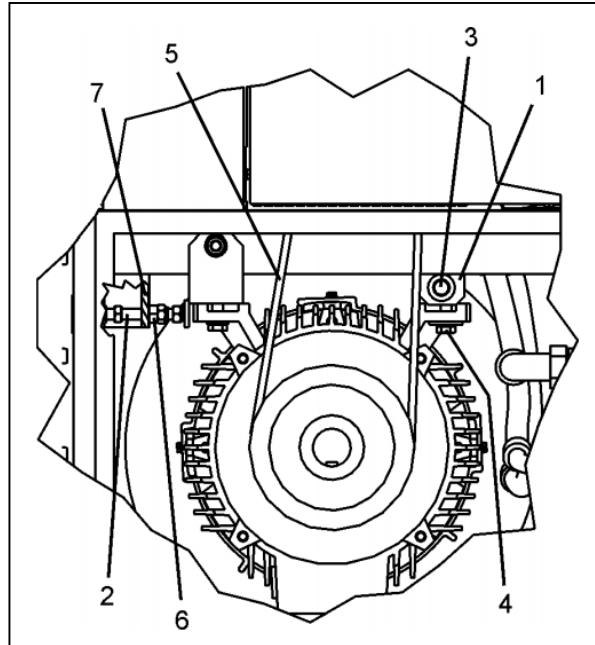

**FIGURE 7-2 - Pre-Filter and Fan Grill**

## SECTION 8 BELT DRIVE SYSTEM

---

The motor power is transmitted to the compressor with a system comprised of heavy-duty v-belts, sheaves, and bushings. Belt tension is provided by the motor weight with the help of a free-pivoting bracket -see Figure 8-1 for details.



**FIGURE 8- 1 – Motor Jacking Assembly**

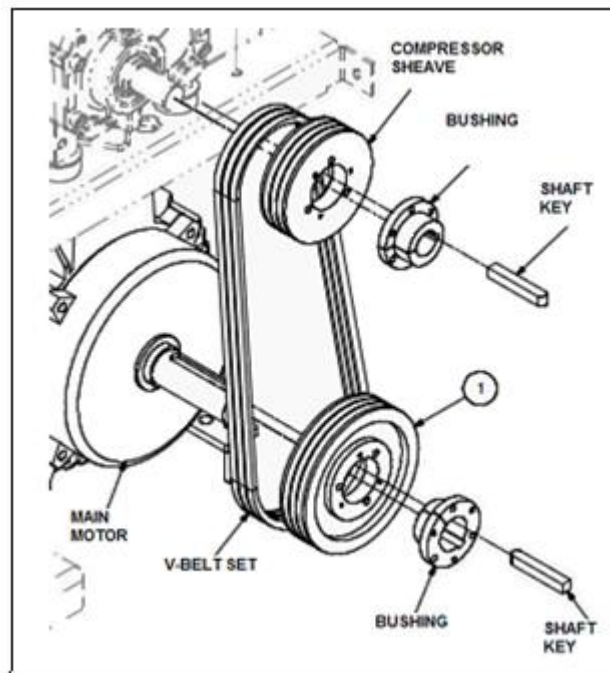

**FIGURE 8- 2 – V-Belt Drive Components**

## UNPACKING THE V-BELT SYSTEM

To protect the belts from shock and strain during transportation, the free-swinging side of the motor frame is locked in place by means of a carrier bracket assembly. Proceed to prepare the belt system for operation as follows - refer to FIGURE 8- 2, for component description:

1. Unlatch and remove the door panel opposite to the main cooling fan panel to gain access to the v-belt system.
2. Lift motor by loosening jam-nut (6) and turning adjusting bolt (2) clockwise via access hole.
3. Loosen and remove fastening screws (3) and (4) as well as carrier bracket (1). Keep this hardware for future use . such as relocating compressor package.
4. Check alignment of the sheave set and make sure that v-belts are properly seated in sheave grooves.
5. Screw out adjusting bolt (2) and secure with jam-nut (6) to allow motor weight to rest on v-belts.

## SHEAVE SET ALIGNMENT

1. Use a straight edge for alignment checks.
2. Check parallel alignment. It should be simple to control by moving one of the sheave/bushing pairs along the shaft to match the other.
3. Check angular alignment. The misalignment  $A = \text{ArcTan} * ((X2-X1)/D)$ , where calculated A is in degrees and measured X1, X2 and D are in inches or mm.
4. The allowable total misalignment is 0.5 degrees for best belt longevity. As reference, 0.5 degrees represents a gap (e.g., X1-X2) of 0.05" (1.33mm) over a 6" diameter sheave.

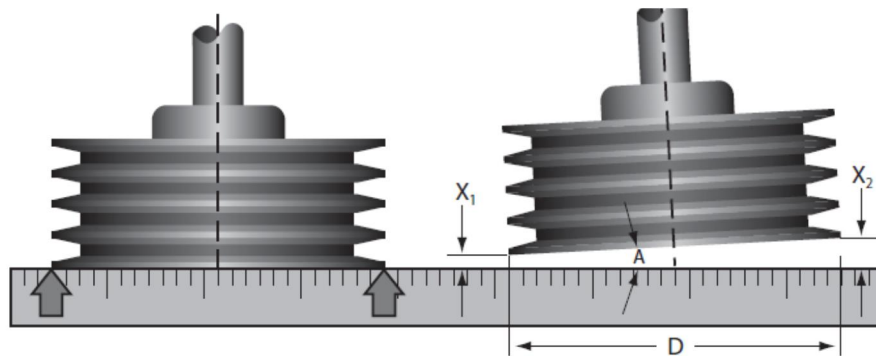

FIGURE 8- 3 - Measuring Angular Misalignment



**Check sheave misalignment prior to start compressor operation. Failure to do so may shorten the operational life of the belts.**

## REPLACING THE COMPRESSOR BELTS

When signs damage (e.g., wear, tear, breakage, etc.) appear on any belt, replace the complete set of three (3) v-belts as follows:

1. Disconnect, lockout and tagout the power supply to the starter
2. Unlatch and remove the door panel opposite to the main cooling fan panel to gain access to the v-belt system . see Figure 8-2, for details.
3. Remove the compressor shaft belt guard.
4. Raise the motor to remove the belt set. This is accomplished by turning the jacking screw clockwise (after loosening the jam nut) and raising the motor body until the v-belts can be dismantled from the motor sheave.
5. Replace the old belts with new ones. For proper belt life, use only genuine Champion belts.
6. Check the sheave alignment.
7. Turn the jacking screw counter-clockwise to lower motor and transfer its weight unto the belt set. Make sure that the belts remain aligned into each corresponding groove. Keep turning jacking screw until it clears base frame surface by at least one inch and jam in with provided nut.

## REPLACING THE SHEAVES

1. Follow steps 1 through 4 given above to replace the compressor belts.
2. Remove the belts.
3. Carefully sketch or photograph the orientation of each sheave/bushing pair as they sit on their respective shaft. You'll need this information to re-install each pair.
4. Loosen and remove the mounting screws securing the sheave to companion bushing. Install the removed screws in the jack holes provided on the sheave and turn each in to pry the bushing loose from the sheave. Remove the sheave and bushing from the shaft.
5. When installing a new sheave / bushing pair, remove all protective grease their surfaces.
6. Insert the mounting screws in the sheave / bushing pair and lightly tighten them.
7. Clean the shaft and mount the sheave / bushing pair. Align the motor sheave to the air end sheave. When mounting the sheave / bushing pair, the bushing clamps to the shaft first, the sheave can still be moved a little. This can affect the alignment of the sheaves.
8. Tighten the mounting screws evenly.
9. Tap the bushing lightly with a drift, and retighten the screws. REPEAT THIS PROCEDURE SEVERAL TIMES TO MAKE SURE THE BUSHING AND SHEAVE ASSEMBLY IS TIGHT ON THE SHAFT.
10. Fill the holes in the bushing/sheave with grease to protect them from dirt and debris.
11. Replace the old belts with new ones. For proper belt life, use only genuine Champion belts.
12. Check the sheave alignment - Refer to Sheave Set Alignment Figure 8-3.



## SECTION 9 SERVICING OF MISCELLANEOUS DEVICES

This section will cover basic maintenance of various control devices used with the compressor package. Refer to Fig 9-1 for pictorial with general locations of these devices.

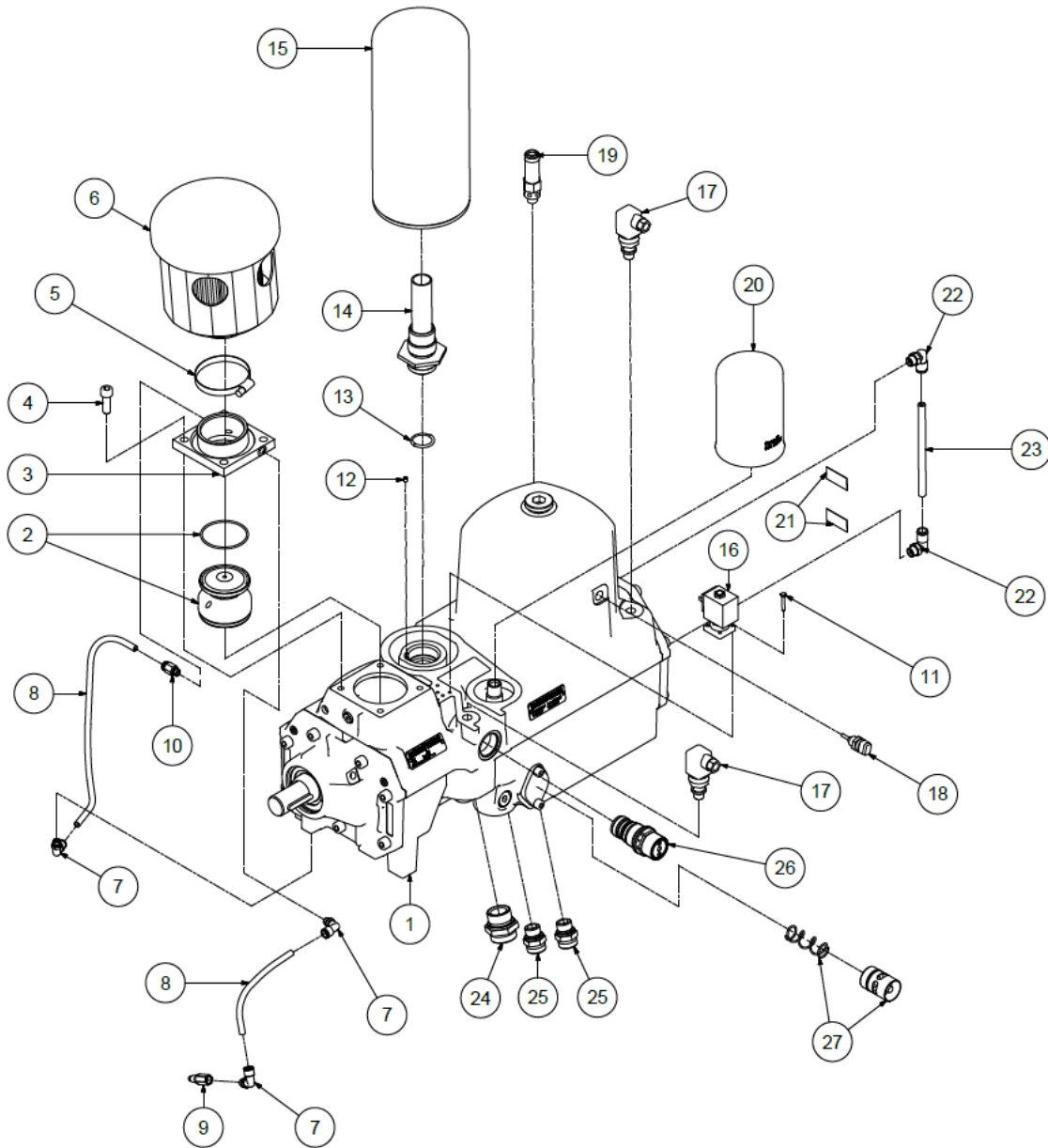
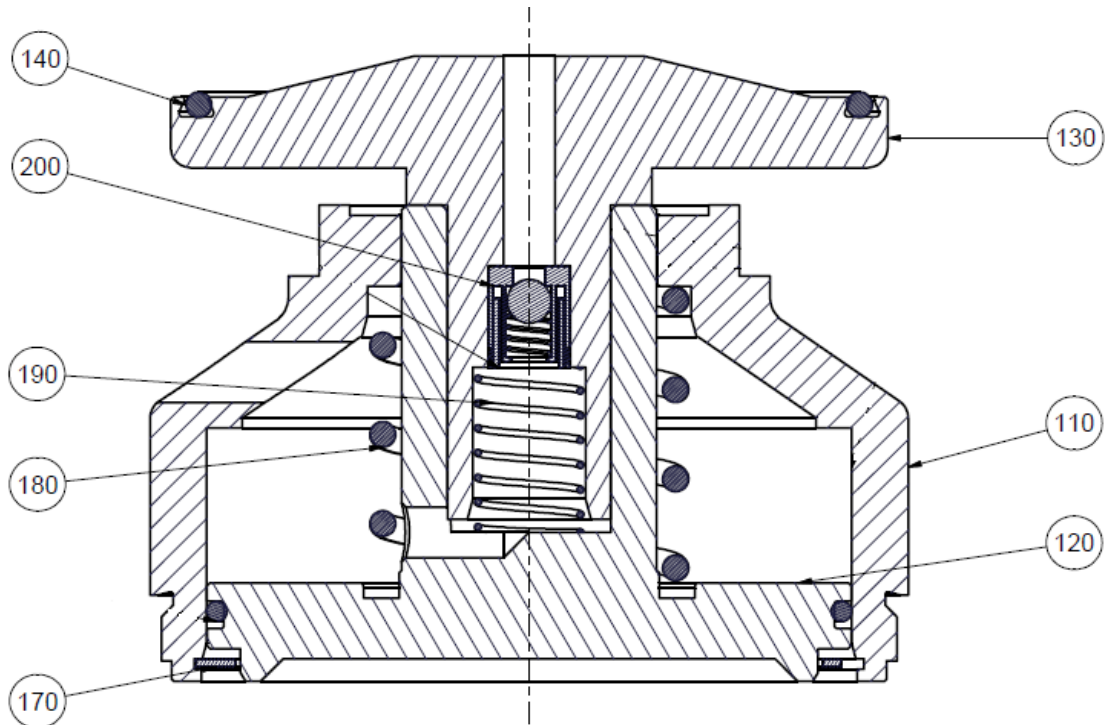

FIGURE 9- 1 –Exploded View of EK100 Compressor

## **INLET CONTROL VALVE ASSEMBLY (2)**

**Inlet-Valve Assembly** - This device is located within and below the intake flange of the compressor - see Figure 9-2 for internal details and Figure 4-6 for schematic details.

During the loaded state, the inlet poppet remains open and enables atmospheric air to enter the compressor inlet - this is done by venting to atmosphere the gas trapped underside of the piston via a check valve. During the unloaded state, a two-way solenoid valve feeds pressurized air underneath the piston, forcing it and the inlet poppet upward and blocking-off the compressor intake.



**FIGURE 9- 2 – Inlet Valve Assembly**

<b>110</b>	<b>Cylinder</b>
<b>120</b>	<b>Piston</b>
<b>130</b>	<b>Inlet Poppet</b>
<b>170</b>	<b>Piston Retainer Spring</b>
<b>180</b>	<b>Compression Spring – Piston</b>
<b>190</b>	<b>Compression Spring – Poppet</b>
<b>200</b>	<b>Check Valve</b>



**Air/oil pressure will cause severe personal injury or death. Shut down compressor, relieve system of all pressure, disconnect, lockout and tagout power supply to the starter before removing valves, caps, plugs, fittings, bolts and filters.**

**Inlet Valve (Body) Inspection** - The valve does not require maintenance or lubrication. If air/oil leaks develop across the valve disc during pressurized conditions (e.g., machine stopped), valve seals should be inspected for wear and tear signs:

1. Be sure the unit is completely off and oil sump is depressurized.
2. Disconnect, lockout and tag out power supply to the compressor package.
3. Close (when provided) valve isolating compressor package from air system.
4. Refer to Figure 9-1 for hardware details.
5. Loosen and remove the air filter element.
6. Remove four bolts securing inlet flange to the compressor body and remove the flange.
7. Remove the poppet assembly and the poppet return spring.
8. Unscrew the valve body from the compressor housing using the hex pattern provided on the valve body . see Figure 9-3 for details.
9. Inspect poppet seals (O-rings) for wear and tear.
10. In case of noted malfunction (e.g., valve will not open/close properly with good air signal), unless a damaged or worn component can be identified and/or repaired, replace the complete inlet valve assembly.
  - Remove retainer ring to release piston assembly free.
  - Inspect the piston seal and piston return spring. If any component if found worn or damaged, replace the complete valve.
  - Re-assembly the piston assembly in reverse order.
11. Reinstall inlet valve in reverse order.

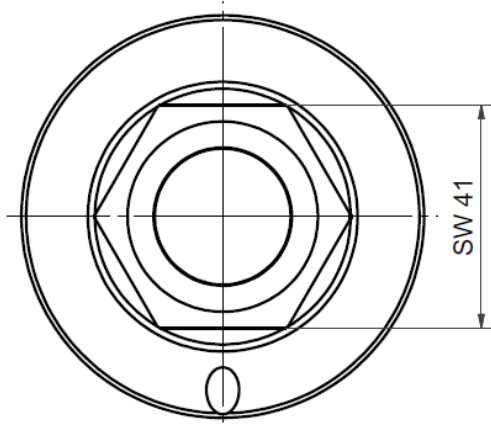

**FIGURE 9- 3 – Inlet Valve Body Hex**

## **PRESSURE RELIEF VALVE (19)**

**Pressure Relief Valve** - This device protects the pressure-containing components of the compressor package against pressures exceeding 218 psig. It is installed on the wet-side of the oil sump.



**FIGURE 9- 4 - Pressure Relief Valve**



**Before inspecting the pressure relief valve, release air pressure, lockout and tagout the power supply to the compressor package. Failure to release pressure or properly disconnect the power may result in personal injury or death.**



**Never paint, lubricate or alter a relief valve. Do not plug vent or restrict.**



**Operation of the unit with improper relief valve setting can result in severe personal injury or machine damage. Ensure properly set valves are installed and maintained.**

**Pressure Relief Valve Check During Operation** - The pressure relief valve has no user-serviceable or repairable components. However, it should be tested for proper operation at least once every year. To test the pressure relief valve:

- Raise the system operating pressure to its normal level
- Pull the stem ring to open valve and let it vent for a few seconds.
- Release the stem ring to close the valve.

## **MINIMUM PRESSURE VALVE (26)**

**Minimum Pressure Valve (MPV) Inspection** – This device has no user-serviceable or repairable components. If it fails to maintain adequate minimum pressure (65psig) or fails to check the backflow of system compressed air after compressor stoppage, replace it as follows:

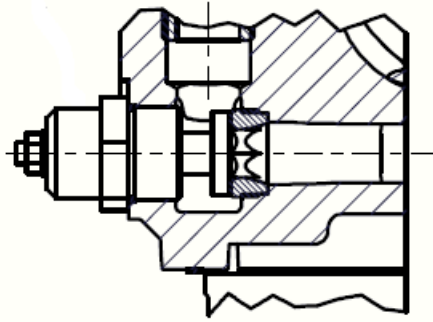

**FIGURE 9- 5 - Minimum Pressure Valve and Seat**



**Air/oil pressure will cause severe personal injury or death. Shut down compressor, relieve system of all pressure, disconnect, lockout and tagout power supply to the starter before removing valves, caps, plugs, fittings, bolts and filters.**

1. Be sure the unit is completely off and that no air pressure is in the oil reservoir and in the air cooled after cooler. Close the service valve.
2. Disconnect lockout and tagout the power supply to the starter.
3. Unscrew the minimum pressure valve assembly from compressor housing and remove.
4. Inspect the valve seat surface screwed into the compressor housing. Cleanse or replace as needed. Note that fitting an O-ring on the hex wrench body helps hold the seat in position during installation.
5. Assemble the MPV assembly into the host manifold.
6. Run the unit and check for leaks.
7. If a new MPV has been fitted, its proper setting must be adjusted:
  - a. Make sure the site pipe system has a means to vent the compressor air to atmosphere with a valve. If this is not available, temporarily fit a ball valve.
  - b. Start the compressor and monitor the wet and dry sump pressure sensors at the GD Pilot controller display.
  - c. Open the site vent valve to limit the dry sump pressure to about 40psig (2.8bar)
  - d. Loosen the jam nut on the TMV adjusting stem and screw it in until the wet sump reaches 70psig (4.8bar).
  - e. Tighten the jam nut on the TMV adjusting stem.
  - f. Close the site vent valve.

## **THERMOSTATIC MIXING VALVE (27)**

**Thermostatic Mixing Valve (TMV) Inspection** – This device has no user-serviceable or repairable components. Refer to Section 5, for further details on this device. If it fails to maintain adequate compressor discharge temperature, replace it as follows:

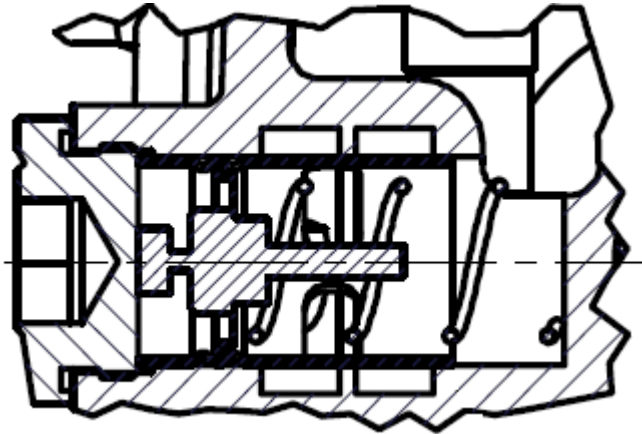
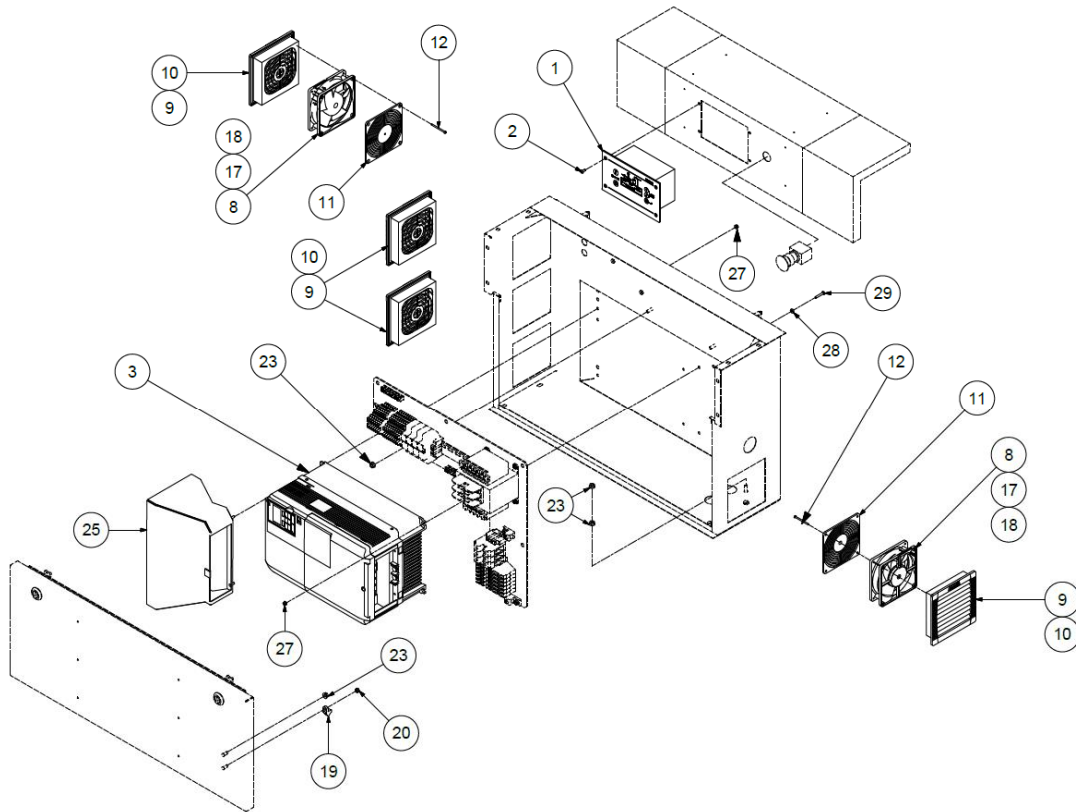

**FIGURE 9- 6 – Thermostatic Mixing Valve**

1. Be sure the unit is completely off and that no air pressure is in the oil reservoir and in the air cooled after cooler. Close the service valve.
2. Disconnect lockout and tagout the power supply to the starter.
3. Unscrew the hex cap holding the TMV assembly within the manifold block. Retrieve the TMV body and its spring from the compressor housing.
4. Inspect the valve seat surfaces for damage or foreign matter. Note its setting temperature . it is stamped on the valve seat area.
5. Immerse the valve body in a bath of compressor oil; heat the oil slowly and note the temperatures at which seat first starts moving and at it finally stops moving. Replace the device if one of the following conditions is present:
  - a. The stamped setting on the valve seat is not correct.
  - b. The seat fails to stroke fully at the correct temperature.
6. Assemble the TMV assembly into the housing in the reverse order.
7. Run the unit and check for leaks.

## **ELECTRICAL BOX COOLING SYSTEM MAINTENANCE (Variable Speed Variant only)**

In order to maintain the VFD module in good working order, its external filters, internal ventilation fans and heat sink must be inspected for debris and cleansed one per year. Follow these steps:



**FIGURE 9- 7 – Control Panel Cooling Hardware**

### **Cooling System Inspection**

1. De-energize, lockout and tagout incoming electrical power to the compressor package.
2. Remove VFD exhaust air duct 25 in Figure 9-7.
3. Inspect external cooling fan/filter assemblies in Figure 9-7.
4. Remove dust and debris from fan with a vacuum cleaner or replace if not operational. Contact Champion for a replacement cooling fan assembly.
5. Shake off debris and gently wash foam filter medial under tap water and dry off completely. Replace if damaged.
6. Remove VFD internal cooling fans to access the outlet segment of the heat sink duct . refer to the following section **VFD Cooling Fan Removal and Replacement** for removal instructions.
7. Inspect the heatsink surfaces from the inlet segment of the heat sink duct . be aware that its surfaces may be hot. Remove debris and dust from its surfaces with a vacuum cleaner placed on the outlet segment of the heat sink duct.
8. Reinstall the VFD internal cooling fans, VFD module, exterior filters and exhaust air duct in the reverse order.

## VFD Cooling Fan Removal and Replacement L15RS / L18RS

1. Make sure that steps 1 and 2 of “Cooling System Inspection” have been completed.
2. Depress the right and left sides of the fan cover tabs and pull upward. Remove the fan cover from the top of the drive per Figure 9.8 – one (1) fan assembly shown, but the same procedure applies to two (2) fan assembly.
3. Remove the cooling fan module. Disconnect the individual plug connector and remove fans – per Figure 9.9.
4. Install the replacement fans – make sure to properly align individual plug prior to connection – per Figure 9.10

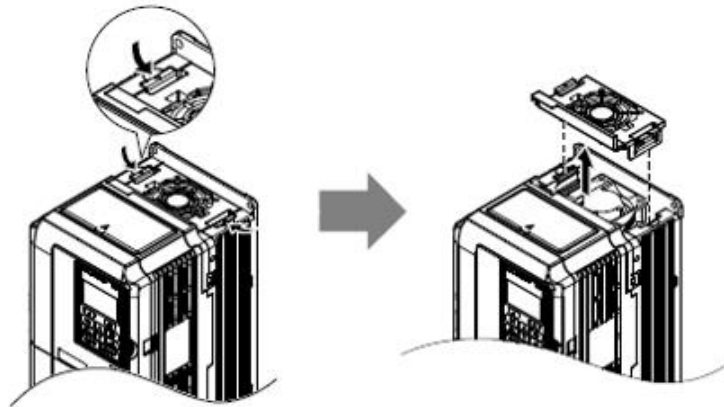

**FIGURE 9- 8 – VFD Fan Removal**

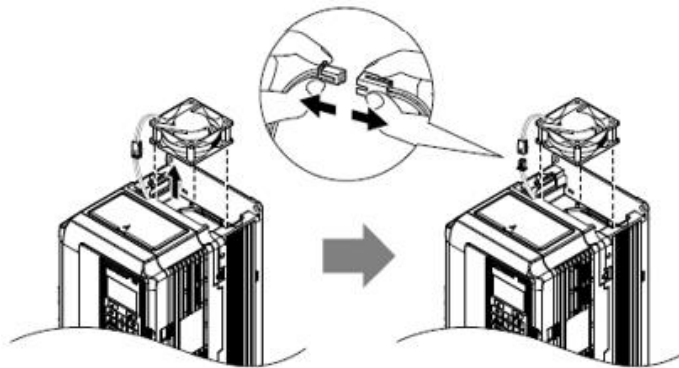

**FIGURE 9- 9 – VFD Fan Disconnect**

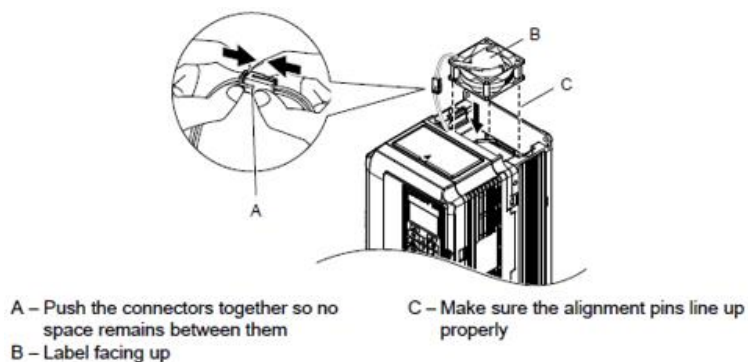

**FIGURE 9- 10 – VFD Fan Reconnect**



## VFD Cooling Fan Removal and Replacement L22RS

1. Make sure that steps 1 and 2 of “Cooling System Inspection” have been completed.
2. Depress the right and left sides of the fan finger guard, free the fan finger guard leading by lifting the back end first – per Figure 9.11
3. Lift out the back end of the fans first. Unplug the relay connector and free the fans from the drive – per Figure 9.12
4. Install the replacement fans by properly connecting the fan power lines and placing the power supply connectors and cable into the recess of the drive – per Figure 9.13 & 9.14
5. Reinstall the fan finger guard – per Figure 9.15

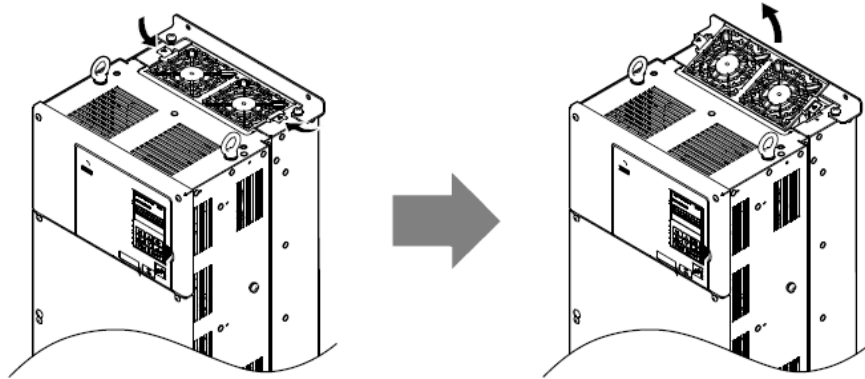

FIGURE 9- 11 – VFD Fan Finger Guard Removal

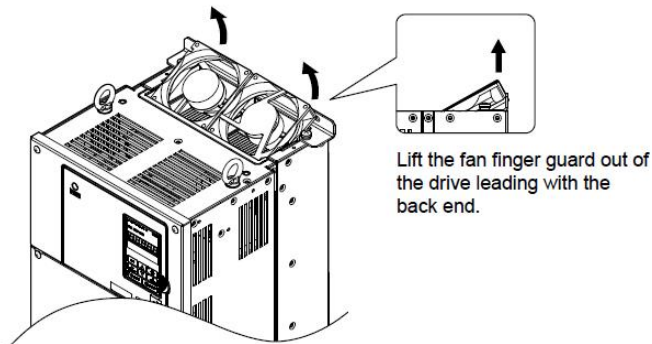

FIGURE 9- 12 – VFD Fan Disconnect / Removal

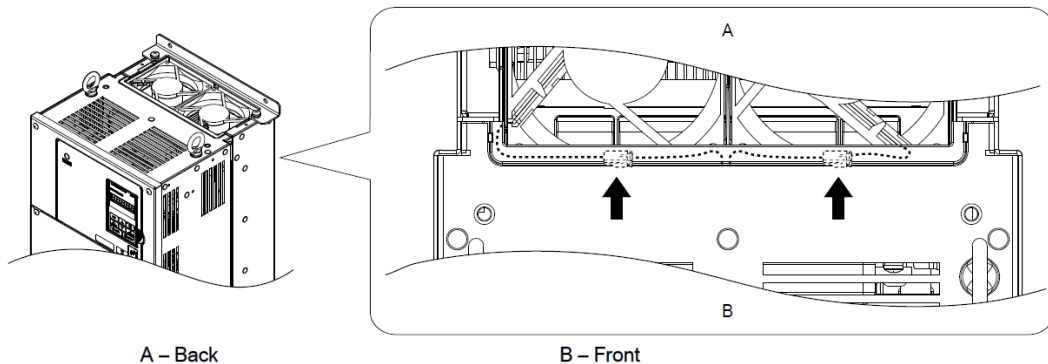
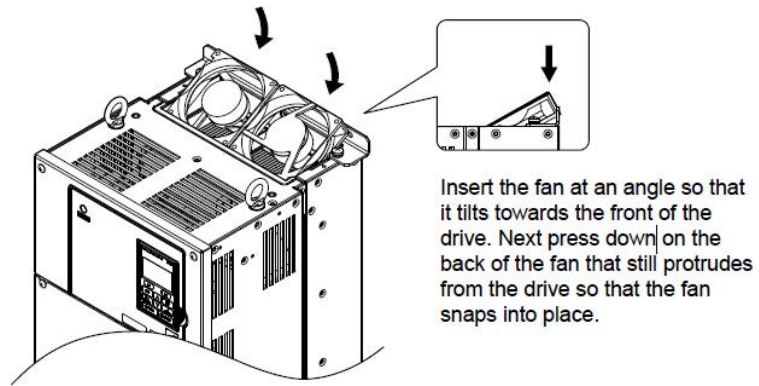
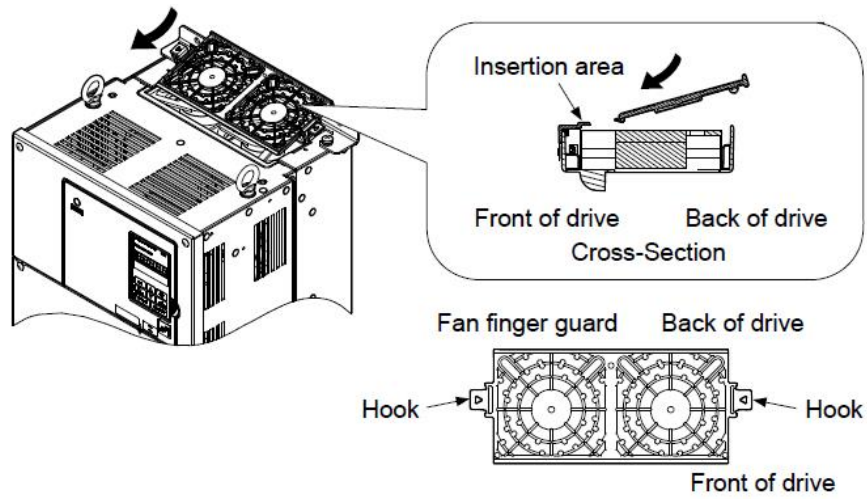

FIGURE 9- 13 – VFD Fan Reconnect



**FIGURE 9- 14 – VFD Fan Install**



**FIGURE 9- 15 - VFD Fan Finger Guard Install**

## SECTION 10 TANK MOUNTED COMPRESSOR - TOTAL SYSTEM

---

**DESCRIPTION** - The basic compressor can be furnished mounted on an optional compressed air receiver (120 and 240 gallon sizes) and paired to an optional CRN, CRE, or GSRN compressed air dryer, as shown on Figure 1-4.

- Refer to Figure 1-4 for dimensioned outline drawing.
- Refer to Section 4 for the description of the main components that comprise the Total System.
- Refer to vendor-supplied instruction manual included with the refrigerated dryer for full details on the installation, operation and maintenance of this optional device when supplied.

It is critical to refer to the vendor-supplied instruction manual, included with the refrigerated dryer, for full details on the installation, operation and maintenance of this optional device. When the dryer is part of the Total System, the following are some of the critical items to keep in mind:

- Dryer models corresponding to compressor package models:

Compressor Model	CRN Dryer Model	CRE Dryer Model	GSRN Dryer Model
<b>L15(RS)</b>	CRN100	CRE90	GSRN100
<b>L18(RS)</b>	CRN125	CRE120	GSRN125
<b>L22(RS)</b>	CRN150	CRE140	GSRN150

- Installation - Package must be installed in a location with an ambient temperature range of 40°F to 110°F (3°C to 43°C). Consult Champion for operation outside this range.
- Discharge service pipe - The discharge service line connection is provided at the outlet of the dryer or optional bypass valve assembly. A hand operated valve, (air service valve) and a separate (swing-type) check valve must be installed between the unit and the customer's air system. If a fast operating valve such as a ball valve is used, it must be closed slowly to give the intake valve time to shut and keep the discharge pressure from spiking.
- Electrical power connections - Provide a grounded 1ph-60Hz-115vac supply to the dryer. Refer to the dryer serial number tag for the proper ampacity.
- Starting and stopping the dryer -
  - Energize the receptacle - green power light will illuminate on the dryer control panel (CRN only).
  - Toggle ON/OFF switch to the ON position to start dryer operation. It is recommended that the dryer be started 15min before the compressed air flow begins.
  - Do not stop or de-energize the dryer during the normal operational shift (e.g., 8 hrs) of compressed air system.
  - The dryer runs continuously when turned on. This is normal operation.
  - Toggle ON/OFF switch to the OFF position to stop dryer operation.

## SECTION 11 MAINTENANCE SCHEDULE

---

### SERVICE CHECK LIST .

**Air Filter and Pre-Filter** - Operating conditions determine frequency of service. See %Air Filter,+ SECTION 7.

**Motor Lubrication** - Refer to Section 2.

#### Every 8 Hours Operation

1. Check the reservoir oil level - add oil if required. See Section 5.
2. Observe if the unit loads and unloads properly.
3. Check discharge pressure and temperature.
4. Check control panel display for advisory text messages.

#### Every 125 Hours Operation

1. Check for dirt accumulation on oil, air core finned faces and the cooling fan. If cleaning is required, clean the exterior fin surfaces of the cores by blowing compressed air carrying a nonflammable safety solvent in a direction opposite that of the cooling fan air flow. This cleaning operation will keep the exterior cooling surfaces clean and ensure effective heat dissipation.

#### Every 2000 Hours Operation

1. Change oil filter element.

#### Every 4000 Hours Operation

1. Change the compressor lubricant. Under adverse conditions, **change more frequently** (refer to %Oil Change Interval+, Figure 5-2. Flush system if required.

#### Every Year

1. Check the pressure relief valve for proper operation. See Section 9.
2. Change oil separator. See %Removal of Oil Separator for Inspection or Replacement+, Section 5, for further details.

## MAINTENANCE SCHEDULE (See Detail Notes above)

Maintenance Action	As Indicated by GD Pilot Controller	Every 8 Hours	Every 50 Hours	Every 125 Hours	Every 2000 Hours	Every 4000 Hours	Every Year
Check/Change Air Filter.....							•
Check/Change Package Inlet Filters .....			•				
Change Oil Separator .....	•						•
Check Reservoir Oil Level **.....		•					
Check for Proper Load/Unload.....		•					
Check Dirt Accumulation on Cooler.....				•			
Change Oil Filter Element & Clean Oil Return Orifice...					•		
Change Compressor Lubricant (RotorLub 4000) * .....						•	
Check Relief Valve.....							•
Check Condition of Hoses .....						•	
Check Operation of Condensate Removal Drain Valve		•					

**FIGURE 11- 1 – Maintenance Schedule**

\* See Oil Change Interval Chart, Figure 5-2, for specific lubricant life.

\*\* Must be checked when the compressor is stopped and the air/oil mixture is separated.

## SECTION 12 TROUBLESHOOTING

SYMPTOM	POSSIBLE CAUSE	REMEDY
<b>Compressor fails to start</b>	1. No electrical power.	1. Check main disconnect, fuses and supply line.
	2. Motor starter overload relay tripped.	2. Reset and investigate cause of overload.
	3. Pressure in reservoir.	3. Inspect unload valve.
	4. Wrong lead connections	4. Change leads.
	5. Emergency stop depressed.	5. Release button.
	6. Unacknowledged fault	4. Clear fault at controller
<b>Compressor starts but stops after a short time</b>	1. High separator/ high compressor temperature shutdown event	1. See High Discharge Air Temperature, +this section.
	2. Blown fuse in starter/ control box.	2. Replace fuse (investigate if fuses continue to blow).
	3. Motor starter overload relay tripped.	3. Reset and investigate cause of overload.
	4. Fast pressure buildup due to open inlet valve	4. Inspect inlet valve and unloader valve operation. Replace if faulty.
	5. High oil viscosity	5. Review oil type for ambient temperature or provide site heating.
<b>Compressor does not unload (or load)</b>	1. Improperly adjusted control.	1. Refer to Control Manual ZS1054347 and adjust control.
	2. Faulty inlet valve or unloaded valve solenoid.	4. Inspect and/or replace faulty component.
<b>Compressor cycles from load to unload excessively</b>	1. Insufficient receiver capacity.	1. Increase receiver size.
	2. Restriction in service piping.	2. Inspect and clean service piping.
	3. Pressure range too narrow.	3. Extend pressure range.
<b>Compressor starts too slowly</b>	1. Minimum Pressure Valve is faulty.	1. Inspect and/or replace.
	2. Supply voltage is too low.	2. Check the supply voltage.
<b>Compressor does not reach load pressure</b>	1. Restricted air filter.	1. Clean or replace filter.
	2. Partially open inlet valve.	2. Inspect, clean or replace inlet valve.

<b>SYMPTOM</b>	<b>POSSIBLE CAUSE</b>	<b>REMEDY</b>
	3. Minimum pressure valve stuck closed.	3. Replace valve.
	4. Oil separator clogged.	4. Replace.
	5. Condensate drain solenoid valve is faulty.	5. Inspect and replace.
	6. Leaks in the compressed air system.	6. Check for leaks, fix any leaks found.
	7. V-Belts broken.	7. Replace complete set.
	8. V-Belts slipping.	8.a Inspect and clean belt. 8.b Check that motor pivots freely on bracket shaft.
	9. Pressure limits incorrectly set.	9. Check/correct pressure limits in the GD Pilot Controller.
	10. Aftercooler is frozen	10. Thaw out. This machine cannot operate in temperatures below 32° F (0° C).
<b>High discharge air temperature</b>	1. Dirty or clogged cooler core or fins.	1. Clean cooler.
	2. Insufficient cooling air flow.	2. Provide unrestricted supply of cooling air.
	3. Clogged oil filter or cooler (interior).	3. Replace filter or clean cooler.
	4. Low compressor oil level.	4. Add oil to proper level.
	5. Faulty temperature sensor.	5. Replace sensor.
	6. Thermostatic mixing valve stuck open.	6. Inspect and/or replace valve.
<b>Excessive oil consumption</b>	1. Oil carryover through lines.	1. See %Oil Carryover+; in this section.
	2. Oil leaks at all fittings and gaskets.	2. Tighten or replace fittings or gaskets.
	3. Shaft seal leaking.	3.a Inspect scavenge orifice

SYMPTOM	POSSIBLE CAUSE	REMEDY
<b>Oil carryover</b>	1. Overfilling the reservoir.	1. Drain excess oil from system.
	2. Clogged scavenge orifice	2. Inspect and cleanse.
	3. Ruptured oil separator element.	3. Replace element.
	4. Loose assembly.	4. Tighten all fittings and gaskets.
	5. Foaming caused by use of incorrect oil.	5. Use Champion RotorLub lubricating coolant.
	6. Inoperative minimum pressure valve.	6. Inspect and/or replace.
	7. Operation at elevated discharge temperatures.	7. Reduce temperature. See High Discharge Air Temperature, this section.
	8. Water condensate in oil.	8. Check oil reservoir temperature and if low, change thermal mixing valve element to one with higher temperature setting.
<b>Excessive water in air delivery line</b>	1. Water separator drain (basic unit or total system receiver and/or dryer) malfunction.	1. Inspect and cleanse or replace drain float valve
	2. Dryer not energized	2. Check that dryer is plugged and turned on.
	3. Dryer bypass valve is in bypass position	3. Inspect and cleanse.
	4. Dryer malfunction	4. Refer to dryer manual for further details.

 **DANGER**



**Air/oil under pressure will cause severe personal injury or death. Shut down compressor, relieve system of all pressure, disconnect, lockout and tagout power supply to the starter before removing valves, caps, plugs, fittings, bolts and filters**



## **TROUBLESHOOTING VOLTAGE PROBLEMS**

The compressor package has been designed, built, and tested to operate within one of the following standard ranges:

200-208 Volts, 60 Hertz (Fixed Speed models only)

230-240 Volts, 60 Hertz

380-400 Volts, 50/60 Hertz

460-480 Volts, 60 Hertz

575-600 Volts, 60 Hertz

Connection to higher voltages will reduce the life of electrical devices within the compressor package. As voltages get further above the design range, other symptoms may show up.

High voltages may lead to high motor currents. The overload relay will sense these and shut down the compressor to protect the motor.

If the power supply and/or control transformer primary fuses blow, check that the devices are properly connected for the incoming line voltage.

Operation with lower voltages will reduce motor life and load capacity. As voltages get further below the design range, other symptoms may show up.

Low voltages may lead to high motor currents. The overload relay will sense these and shut down the compressor to protect the motor. If voltage is low while the compressor is off, locate and correct the cause. If the voltage drops low only while the compressor is running, look for poor connections or undersized wiring.

If any of the starters or contactors within the box chatters, or if the electronic controller drops out while attempting to start, it is a clear indication that the wiring is inadequate for the compressor. Look for poor connections or undersized wiring.

## Standard Warranty

Oil-Lubricated Rotary Screw / Rotary Vane Compressor Packages  
 Vision, L, LRS, RotorChamp, LV, LVR, HR, HRRS, HV, HV RS, and V-Series

### STANDARD WARRANTY

Champion (the "Company") warrants to each original retail purchaser ("Purchaser") of its new products from the Company or its authorized distributor that such products are, at the time of delivery to the Purchaser, free of defects in material and workmanship. **This Standard Warranty statement applies to compressors shipped after May 1<sup>st</sup>, 2015.**

### STANDARD WARRANTY PERIOD

The Company's obligation under this warranty is limited to repairing or, at its option, replacing, during normal business hours at an authorized service facility of the Company, any part which in its judgment proved not to be as warranted within the applicable warranty period as follows. **Regular maintenance in accordance with the service manual is required. Use of genuine Champion OEM parts and lubricants are highly recommended. If a component failure is deemed a result of using non-genuine Champion parts and lubricants, warranty will not be allowed.**

COMPONENT	STANDARD WARRANTY COVERAGE	DETAILS
Package	12 months from startup or 15 months from date of shipment to first purchaser, whichever occurs first	All components within the package, excluding normal wear items
Airend	24 months from startup or 27 months from date of shipment to first purchaser, whichever occurs first	Normal wearing items, such as shaft seals and inlet valve components, along with the servicing of these items is not covered under the warranty unless deemed as material or workmanship defects. Any disassembly or partial disassembly of the airend, or failure to return the "unopened" airend per Company instructions, will be cause for denial of warranty
Electric Motors	12 months from startup or 15 months from date of shipment to first purchaser, whichever occurs first	Includes both drive motor and cooling fan motor. For nonstandard motors, the original manufacturer's warranty will take precedence.
Major Package Components	24 months from startup or 27 months from date of shipment to first purchaser, whichever occurs first	Includes package controller, variable frequency drive if applicable, air/oil reservoir, air/oil cooler, and precision mixing valve (VS Series)
Labor	<p>Package / Electric Motors: 12 months from startup or 15 months from date of shipment to first purchaser, whichever occurs first</p> <p>Airend / Major Package Components: 24 months from startup or 27 months from date of shipment to first purchaser, whichever occurs first</p>	Service will be provided by Company representative or authorized service personnel, for repair or replacement of any product or part which in the Company's sole judgment is proved not to be as warranted. Labor shall be limited to the amount specified in the Company's labor rate schedule. All costs of transportation of product, parts, and repaired or replacement parts claimed not to be as warranted to and from such service facilities shall be borne by the Purchaser. The Company may require the return of any part claimed not to be as warranted to one of its facilities as designated by Company, transportation prepaid by Purchaser, to establish a claim under this warranty. Replacement parts provided under the terms of the warranty are warranted for the remainder of the Warranty Period.

### NO WARRANTY IS MADE WITH RESPECT TO:

1. ANY PRODUCT WHICH HAS BEEN REPAIRED OR ALTERED IN SUCH A WAY, IN THE COMPANY'S SOLE JUDGMENT, AS TO AFFECT THE PRODUCT ADVERSELY
2. ANY PRODUCT WHICH HAS, IN THE COMPANY'S SOLE JUDGMENT BEEN SUBJECT TO NEGLIGENCE, ACCIDENT, IMPROPER STORAGE, OR IMPROPER INSTALLATION OR APPLICATION
3. ANY PRODUCT WHICH HAS NOT BEEN OPERATED OR MAINTAINED IN ACCORDANCE WITH THE RECOMMENDATIONS OF THE COMPANY
4. ANY RECONDITIONED OR PRIOR OWNED PRODUCT

### STANDARD WARRANTY DISCLAIMER

THE FOREGOING WARRANTY IS EXCLUSIVE AND IT IS EXPRESSLY AGREED THAT, EXCEPT AS TO TITLE, THE COMPANY MAKES NO OTHER WARRANTIES AND HEREBY EXPRESSLY DISCLAIMS ALL OTHER WARRANTIES, INCLUDING WITHOUT LIMITATION, EXPRESSED, IMPLIED OR STATUTORY WARRANTIES, INCLUDING ANY IMPLIED WARRANTY OF MERCHANTABILITY OR FITNESS FOR A PARTICULAR USE. THE REMEDY PROVIDED UNDER THIS WARRANTY SHALL BE THE SOLE, EXCLUSIVE AND ONLY REMEDY AVAILABLE TO PURCHASER AND IN NO CASE SHALL THE COMPANY BE SUBJECT TO ANY OTHER OBLIGATIONS OR LIABILITIES. UNDER NO CIRCUMSTANCES SHALL THE COMPANY BE LIABLE FOR SPECIAL, INDIRECT, INCIDENTAL OR CONSEQUENTIAL DAMAGES, EXPENSES, LOSSES OR DELAYS HOWSOEVER CAUSED. NO STATEMENT, REPRESENTATION, AGREEMENT, OR UNDERSTANDING, ORAL OR WRITTEN, MADE BY ANY AGENT, DISTRIBUTOR, REPRESENTATIVE, OR EMPLOYEE OF THE COMPANY WHICH IS NOT CONTAINED IN THIS WARRANTY WILL BE BINDING UPON THE COMPANY UNLESS MADE IN WRITING AND EXECUTED BY AN OFFICER OF THE COMPANY. THIS WARRANTY SHALL NOT BE EFFECTIVE AS TO ANY CLAIM WHICH IS NOT PRESENTED WITHIN 30 DAYS AFTER THE DATE UPON WHICH THE PRODUCT IS CLAIMED NOT TO HAVE BEEN AS WARRANTED. ANY ACTION FOR BREACH OF THIS WARRANTY MUST BE COMMENCED WITHIN ONE YEAR AFTER THE DATE UPON WHICH THE CAUSE OF ACTION OCCURRED. ANY ADJUSTMENT MADE PURSUANT TO THIS WARRANTY SHALL NOT BE CONSTRUED AS AN ADMISSION BY THE COMPANY THAT ANY PRODUCT WAS NOT AS WARRANTED. WARRANTY IS NOT TRANSFERRABLE



# **CHAMPION**

For additional information, contact your local representative or visit:  
[www.championpneumatic.com/contactus.aspx](http://www.championpneumatic.com/contactus.aspx)

©2018 Gardner Denver, Inc. Printed in U.S.A.

