

CHAMPION

COMPRESSED
AIR ADVISORS
Inc.

Compressed Air Advisors, Inc.

Phone: 877.247.2381

info@compressedairadvisors.com

www.compressedairadvisors.com

R-SERIES

Air Compressors and Units

OPERATION & SERVICE MANUAL

Engine Drive Compressors & Units

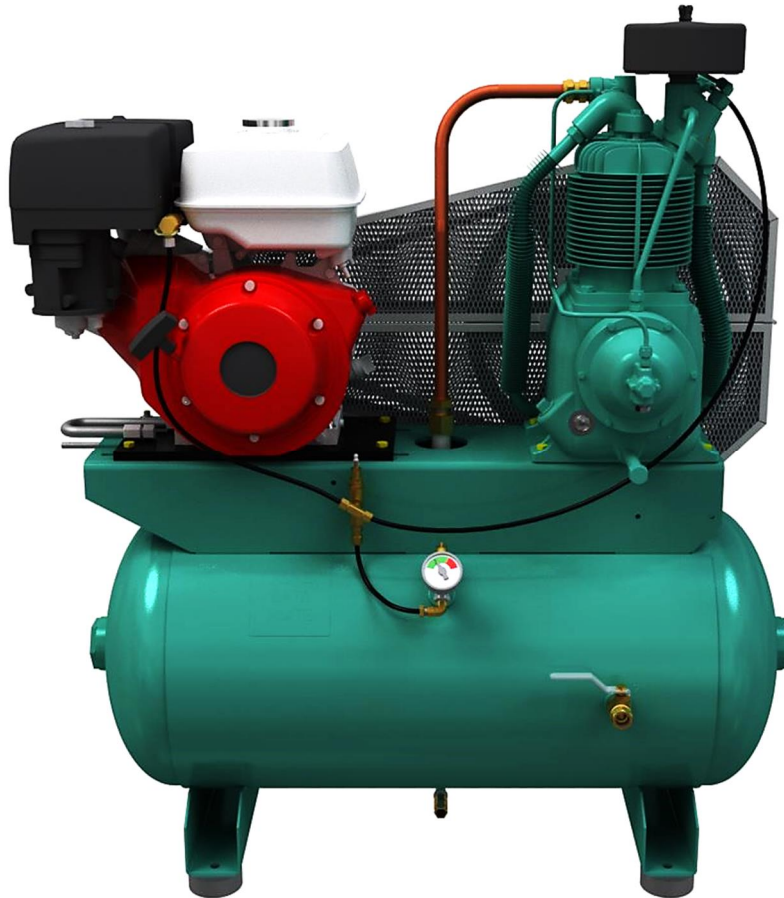

WARNING

THIS MANUAL CONTAINS IMPORTANT SAFETY INFORMATION AND SHOULD ALWAYS BE AVAILABLE TO THOSE PERSONNEL OPERATING THIS UNIT. READ, UNDERSTAND AND RETAIN ALL INSTRUCTIONS BEFORE OPERATING THIS EQUIPMENT TO PREVENT INJURY OR EQUIPMENT DAMAGE.

MAINTAIN COMPRESSOR RELIABILITY AND PERFORMANCE WITH GENUINE CHAMPION® COMPRESSOR PARTS AND SUPPORT SERVICES

Champion® Compressor genuine parts, manufactured to design tolerances, are developed for optimum dependability . specifically for Champion compressor systems. Design and material innovations are the result of years of experience with hundreds of different compressor applications. Reliability in materials and quality assurance are incorporated in our genuine replacement parts.

Your authorized Champion Compressor distributor offers all the backup you need. A worldwide network of authorized distributors provides the finest product support in the air compressor industry. Your authorized distributor can support your Champion air compressor with these services:

1. Trained parts specialists to assist you in selecting the correct replacement parts.
2. A full line of factory tested CHAMPLUBi compressor lubricants specifically formulated for use in Champion compressors.
3. Repair and maintenance kits designed with the necessary parts to simplify servicing your compressor.

Authorized distributor service technicians are factory trained and skilled in compressor maintenance and repair. They are ready to respond and assist you by providing fast, expert maintenance and repair services.

To Contact Champion or locate your local distributor:

Visit: www.championpneumatic.com

Or

Call: (888)436-5499

INSTRUCTIONS FOR ORDERING REPAIR PARTS

When ordering parts, specify Compressor MODEL, HORSEPOWER and SERIAL NUMBER (see nameplate on unit). All orders for Parts should be placed with the nearest authorized distributor.

Order by part number and description. Reference numbers are for your convenience only.

Table of Contents

Introduction	4
Safety and Operation Precautions	5
Explanation of Safety Instructions, Symbols, and Decals	6
Safety and Operation Precautions	6
Unit Hazard Decal List – See Page 8	7
Pump Hazard Decal List – See Page 9	7
Unit Hazard Decals	8
Pump Hazard Decals	9
Installation	10
Air Receiver Installation	15
Operation	16
Compressor Oil Specifications	18
Guide to Maintenance	20
Maintenance Checklist	26
Troubleshooting Chart	27
Maintenance Log	28
Notes	31

Introduction

Champion R Series compressors are the result of advanced engineering and skilled manufacturing. To be assured of receiving maximum service from this machine the owner must exercise care in its operation and maintenance. This book is written to give the operator and maintenance department essential information for day-to-day operation, maintenance and adjustment. Careful adherence to these instructions will result in economical operation and minimum downtime.

Champion Five Year Warranty "R" Series Compressors

CHAMPION warrants each new compressor pump manufactured by **CHAMPION**, mounted on a factory assembled unit, to be free from defects in material and workmanship under normal use and service for a period of sixty (60) months from date of installation or sixty-six (66) months from date of shipment by **CHAMPION** or **CHAMPION** distributor, whichever may occur first. **Applies to the compressor pump only, excluding head valves. Valves, controls and accessories are warranted for the first year only.** Compressor pumps purchased separately would carry a one year warranty.

This five year extended warranty will be prorated over the 5 years as follows:

First Year	-	100% Allowance, Parts and Labor
Second Year	-	90% Allowance, Parts and Labor
Third Year	-	80% Allowance, Parts and Labor
Fourth Year	-	70% Allowance, Parts and Labor
Fifth Year	-	60% Allowance, Parts and Labor

Applies to CHAMPION logo, tank or base mounted complete compressors only.

Express Limited Warranty

CHAMPION warrants each new air compressor unit manufactured by **CHAMPION** to be free from defects in material and workmanship under normal use and service for a period of twelve (12) months from date of installation or eighteen (18) months from date of shipment by **CHAMPION** or **CHAMPION** distributor, whichever may occur first.

CHAMPION makes no warranty in respect to components and accessories furnished to **CHAMPION** by third parties, such as **ELECTRIC MOTORS, GASOLINE OR DIESEL ENGINES** and **CONTROLS**, which are warranted only to the extent of the original manufacturer's warranty to **CHAMPION**. To have warranty consideration, electric motors must be equipped with thermal overload protection.

The extended five year warranty will apply to ASME air receivers provided they are installed on rubber vibro-isolator pads.

When a compressor pump, or component is changed or replaced during the warranty period, the new/replaced item is warranted for only the remainder of the original warranty period.

Repair, replacement or refund in the manner and within the time provided shall constitute **CHAMPION'S** sole liability and your exclusive remedy resulting from any nonconformity or defect. **CHAMPION SHALL NOT IN ANY EVENT BE LIABLE FOR ANY DAMAGES, WHETHER BASED ON CONTRACT, WARRANTY, NEGLIGENCE, STRICT LIABILITY OR OTHERWISE, INCLUDING WITHOUT LIMITATION ANY CONSEQUENTIAL, INCIDENTAL OR SPECIAL DAMAGES, ARISING WITH RESPECT TO THE EQUIPMENT OR ITS FAILURE TO OPERATE, EVEN IF CHAMPION HAS BEEN ADVISED OF THE POSSIBILITY THEREOF.**

CHAMPION MAKES NO OTHER WARRANTY OR REPRESENTATION OF ANY KIND, EXCEPT THAT OF TITLE, AND ALL OTHER WARRANTIES, EXPRESS OR IMPLIED, INCLUDING WARRANTIES OR MERCHANTABILITY AND FITNESS FOR A PARTICULAR PURPOSE, ARE HEREBY EXPRESSLY DISCLAIMED. NO SALESMAN OR OTHER REPRESENTATIVE OF **CHAMPION** HAS AUTHORITY TO MAKE ANY WARRANTIES.

Safety and Operation Precautions

Because an air compressor is a piece of machinery with moving and rotating parts, the same precautions should be observed as with any piece of machinery of this type where carelessness in operation or maintenance is hazardous to personnel. In addition to the many obvious safety rules that should be followed with this type of machinery, the additional safety precautions as listed below must be observed:

1. Read all instructions completely before operating air compressor or unit.
2. For installation, follow all local safety codes, as well as the Occupational Safety and Health Act (OSHA).
3. Do not attempt to remove any compressor parts without first relieving the entire system of pressure.
4. Do not attempt to service any part while machine is in an operational mode.
5. Do not operate the compressor at pressures in excess of its rating.
6. Do not operate compressor at speeds in excess of its rating.
7. Periodically check all safety devices for proper operation. Do not change pressure setting or restrict operation in any way.
8. Be sure no tools, rags or loose parts are left on the compressor or drive parts.
9. Do not use flammable solvents for cleaning the air inlet filter or element and other parts.
10. Exercise cleanliness during maintenance and when making repairs. Keep dirt away from parts by covering parts and exposed openings with clean cloth or Kraft paper.
11. Do not operate the compressor without guards, shields and screens in place.
12. Do not install a shut-off valve in the discharge line, unless a pressure relief valve, of proper design and size, is installed in the line between the compressor unit and shut-off valve.
13. Do not operate compressor in areas where there is a possibility of ingesting flammable or toxic fumes.
14. Be careful when touching the exterior of a recently run engine - it may be hot enough to be painful or cause injury.
15. Inspect unit daily to observe and correct any unsafe operating conditions found.
16. Do not "play around" with compressed air or direct air stream at body. This can cause injuries.
17. Compressed air from this machine must not be used for food processing or breathing air without adequate downstream filters, purifiers and controls.
18. Always use an air pressure regulating device at the point of use. Do not use air pressure greater than marked maximum pressure of attachment.
19. Check hoses for weak or worn condition before each use and make certain that all connections are secure.
20. Always wear safety glasses when using a compressed air blow gun.
21. Engine drive unit precautions:
 - a. Understand the operation of all controls and learn how to stop the engine quickly in case of emergency. Make sure the operator receives adequate instruction before operating the equipment.
 - b. Do not allow children to operate the engine. Keep children and pets away from the area of operation.
 - c. Your engine's exhaust contains poisonous carbon monoxide. Do not run the engine without adequate ventilation. Never run the engine indoors.
 - d. The engine and exhaust become very hot during operation. Keep the engine at least 3 feet away from buildings and other equipment during operation. Keep flammable materials away. Do not place anything on the engine while it is running.

The user of any air compressor package manufactured by **Champion** – A Gardner Denver Co., is hereby warned that failure to follow the preceding Safety and Operation Precautions can result in injuries or equipment damage. However, **Champion** – A Gardner Denver Co., does not state as fact or does not mean to imply that the preceding list of Safety and Operating Precautions is all inclusive, and further that the observance of this list will prevent all injuries or equipment damage.

Explanation of Safety Instructions, Symbols, and Decals



Indicates immediate hazards which will result in severe injury or death.



Indicates hazards or unsafe practice which could result in severe injury or death.



Indicates hazards or unsafe practice which could result in damage to the Champion compressor or minor injury.

NOTICE

Notice is used to notify people of installation, operation, or maintenance information which is important but not hazard related.

Safety and Operation Precautions

OBSERVE, UNDERSTAND, AND RETAIN THE INFORMATION GIVEN IN THE SAFETY PRECAUTION DECALS AS SHOWN IN THE DECAL LIST SECTION.



This reciprocating compressor must not be used for breathing air. To do so will cause serious injury whether air is supplied direct from the compressor source or to breathing tanks for later use. Any and all liabilities for damage or loss due to injury, death and/or property damage including consequential damages stemming from the use of this compressor to supply breathing air, will be disclaimed by the manufacturer.



The use of this compressor as a booster pump and/or to compress a medium other than atmospheric air is strictly non-approved and can result in equipment damage and/or injury. Non-approved uses will also void warranty.



This unit may be equipped with special options which may not be included in this manual. User must read, understand, and retain all information sent with special options.

Unit Hazard Decal List – See Page 8

PART NO.	DESCRIPTION
P10157A	PRODUCT LIABILITY DECAL SHEET - MASTER
1	Unit Pressure Setting
2	WARNING – Tank Pressure
3	DANGER – Breathing Air
4	DANGER – Drain Tank Daily
5	WARNING – Pressure/Safety Valve
6	NOT USED
7	DANGER – Valve Maintenance
8	NOT USED
9	WARNING – Hot Surfaces
10	WARNING – Do Not Remove Fan Guard
11a	NOTICE - Lubricant
11b	NOT USED
12	DECAL – Synthetic or Food Grade Inserts
13	NOT USED
14	DECAL – Pressure Setting: 140-175 PSIG
15	NOTICE – Read and Retain Manuals
16	NOT USED
17	DECAL – Rotation Direction
18	NOT USED

Pump Hazard Decal List – See Page 9

PART NO.	DESCRIPTION
P13805A	PUMP DECAL SHEET – MASTER
A1	NOT USED
A2	NOTICE - Lubricants
B	DECAL – Rotation Direction
C	NOTICE – Read and Retain Manuals
D	DANGER – Breathing Air
E	DECAL – Made in the United States of America

Unit Hazard Decals

1

UNIT PRESSURE FACTORY SET AT

UNIT PRESSURE FACTORY SET AT

1

UNIT PRESSURE FACTORY SET AT

UNIT PRESSURE FACTORY SET AT

2

⚠ WARNING

DO NOT START ENGINE UNLESS TANK PRESSURE IS BELOW 130 PSIG. TO REDUCE TANK PRESSURE, OPEN VALVE ADJACENT TO THIS DECAL.

3

⚠ DANGER

Air from this compressor must not be used for food processing or breathing without adequate filtering. Failure to comply will result in injury or death.

4

⚠ DANGER

DRAIN THIS TANK DAILY! Failure to drain moisture will corrode tank material and lead to tank failure which will cause equipment damage, injury, or death.

5

⚠ WARNING

- RELIEVE TANK PRESSURE BEFORE SERVICING. Failure to do so can result in injury.
- DO NOT ADJUST PRESSURE SWITCH, PILOT VALVE OR SAFETY VALVES. Exceeding factory settings can cause equipment damage and injury.

6

MODEL: _____

SERIAL NO: _____

7

⚠ DANGER

Valves must be replaced in original position. Failure to do this will result in equipment damage, injury, or death. Do not disassemble valves.

9

⚠ WARNING

Do not touch hot surfaces! Contact with these surfaces can cause injury.

10

⚠ WARNING

DO NOT REMOVE BELT OR FAN GUARD. Removal will expose rotating parts which can cause severe injury and/or property damage.

11a

ⓘ NOTICE

YOUR COMPRESSOR HAS BEEN TESTED AND SHIPPED WITH *Champion Plus* FOR OPTIMUM PERFORMANCE. USE ONLY GENUINE CHAMPION PARTS AND LUBRICANTS. CONTACT LOCAL DISTRIBUTOR FOR ADDITIONAL LUBRICANT AND REPLACEMENT PARTS.

11b

ⓘ NOTICE

YOUR COMPRESSOR HAS BEEN TESTED AND SHIPPED WITH **AEON** FOR OPTIMUM PERFORMANCE. USE ONLY GENUINE CAEMER LUBRICANTS, CONTACT LOCAL DISTRIBUTOR FOR ADDITIONAL LUBRICANT AND REPLACEMENT PARTS.

12

FOOD GRADE SYNTHETIC

13

AC-SY AC-FG

14

30-100 PSIG	RESET
70-90 PSIG	RESET
60-90 PSIG	
20-40 PSIG	
140-175 PSIG	
140-170 PSIG	
130-165 PSIG	
95-125 PSIG	
85-115 PSIG	

6

⚠ WARNING

Do not touch hot surfaces! Contact with these surfaces can cause injury.

10

⚠ WARNING

DO NOT REMOVE BELT OR FAN GUARD. Removal will expose rotating parts which can cause severe injury and/or property damage.

8

⚠ DANGER

HIGH VOLTAGE. DISCONNECT POWER SOURCE BEFORE SERVICING.

15

ⓘ NOTICE

Read, understand and retain all labels and Owners Manuals before using this equipment. **IMPORTANT:** Please keep the operating instructions with this compressor unit.

16

INSTRUCTIONS DUAL CONTROL

This unit is equipped with a dual control valve. Open valve completely for continuous run operation. Close valve completely for start-stop operation.

17

Master Decal Set
P/N P10157A

Pump Hazard Decals

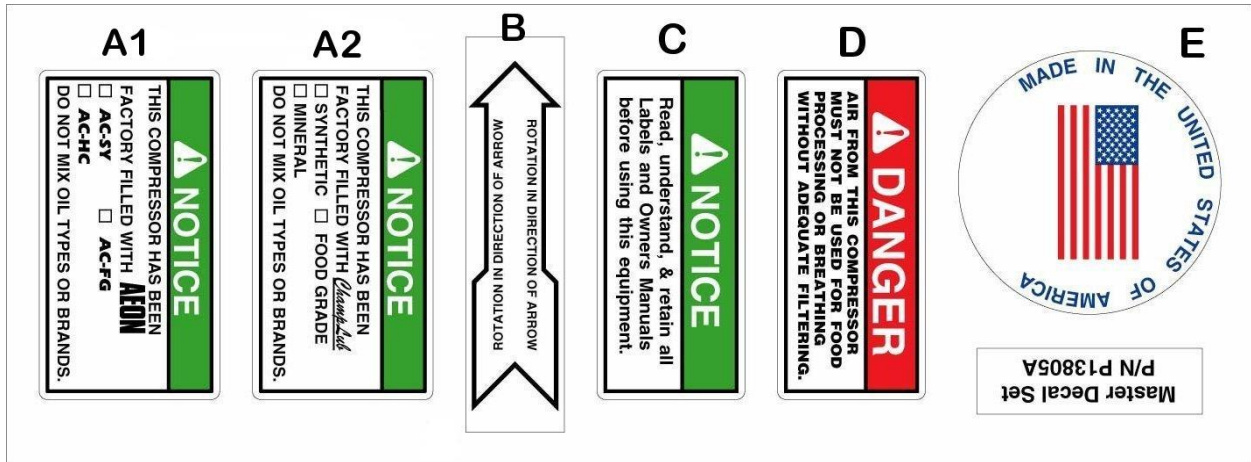

COMPRESSOR
AIR ADVISOR, Inc.

Installation



Do not operate unit if damaged during shipping, handling or use. Operating unit if damaged may result in injury.

1. Permanently installed compressors must be located in a clean, well ventilated dry room so compressor receives adequate supply of fresh, clean, cool, and dry air. It is recommended that a compressor, used for painting, be located in a separate room from that area wherein body sanding and painting is done. Abrasive particles or paint, found to have clogged the air intake filters and intake valves, shall automatically void warranty.
2. Compressors should never be located so close to a wall or other obstruction that flow of air through the fan-bladed flywheel, which cools the compressor, is impeded. Permanently mounted units should be installed so that the belt guard is at least 12" from wall.
3. Place stationary compressors on firm level ground or flooring. Permanent installations are required to be anchored to floor or truck bed. Bolt holes are provided in the air receiver or base feet. Use shims to level the compressor unit. It is recommended that optional vibration isolator pads be installed with the unit. Tanks anchored directly to a floor without vibration isolator pads will not be warranted against cracking. Champion vibration isolator pads must be used for extended warranty to apply to ASME air receivers. See "Air Receiver Installation" section.



Do not tighten the anchor screws/nuts down completely – this will result in undesirable stress on the tank foot. This can cause abnormal vibration and possible cracking of the air receiver, resulting in injury or equipment damage.

4. If installing base mounted unit, make certain the pressure limiting controls are properly installed and operational. The unloading system requires a control air pressure line from the air receiver to be connected to the pilot valve fitting on the pump.
5. A properly sized air check valve must be installed in the discharge piping, between the compressor outlet and the inlet of any receiver tank(s) in the system.
6. Engine driven units installed indoors must have proper engine exhausting out of building. See Safety & Precautions Item 21 (page 5).

Installation (continued)

7. Battery and Wiring Recommendations

A. If engine is connected to a dedicated battery:

- 1) The battery should have a minimum capacity of 24 AH and at least 350 CCA rating.
- 2) The wire size must be a minimum of #4 AWG. If the positive cable is longer than 5 feet or the negative cable is longer than 7.5 feet the wire size should be increased so that the maximum voltage drop from the battery to the unit connection does not exceed 0.5 volts while cranking. The battery location should be selected to keep the connecting leads as short as possible.
- 3) Care should be taken when routing battery leads to insure that the leads are properly supported and insulated.
- 4) The positive lead should be color coded RED and all connections should be enclosed by non-conducting covers. See Figure 1 for Kohler (gas) connection. See Figure 2 for Honda (gas) connection.

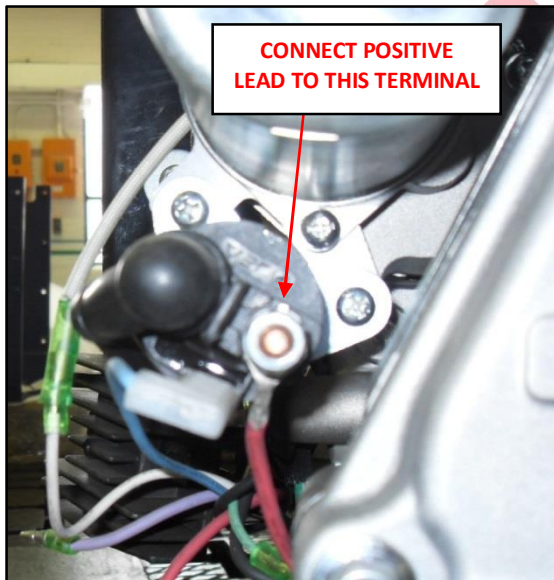

Figure 1

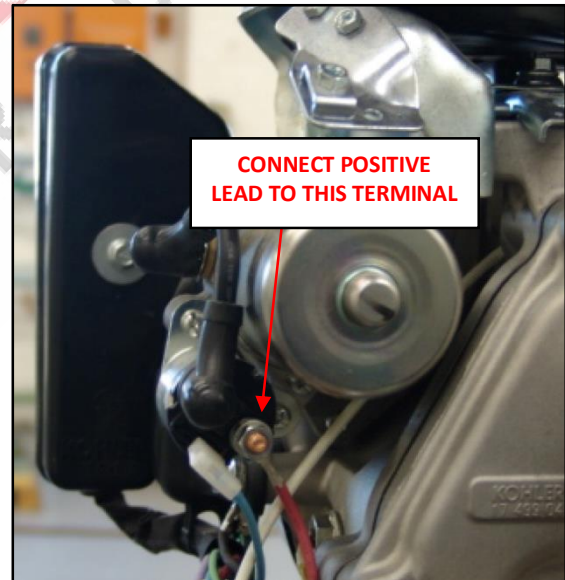

Figure 2

- 5) The negative lead should be connected directly to the engine using one of the four 3/8" diameter mounting foot studs.
- 6) Electrical connections should be regularly inspected to insure that they are clean and tight.

Installation (continued)

B. HONDA GAS ENGINE ONLY: If engine is connected to the vehicle battery:

- 1) The vehicle battery should have a minimum capacity of 24 AH and at least 350 CCA rating.
- 2) The wire size must be a minimum of #4 AWG. If the positive cable is longer than 5 feet or the Negative cable is longer than 7.5 feet the wire size should be increased so that the maximum voltage drop from the battery to the unit connection does not exceed 0.5 volts while cranking. The battery location should be selected to keep the connecting leads as short as practical.
- 3) The Honda engine's charging system should be disabled to prevent the damage from the vehicles charging system. This is done by removing the rectifier diode that is located in the key switch box.
 - a) Remove the Phillips head screw holding the black plastic cover on the back of the key switch box See Figure 3.

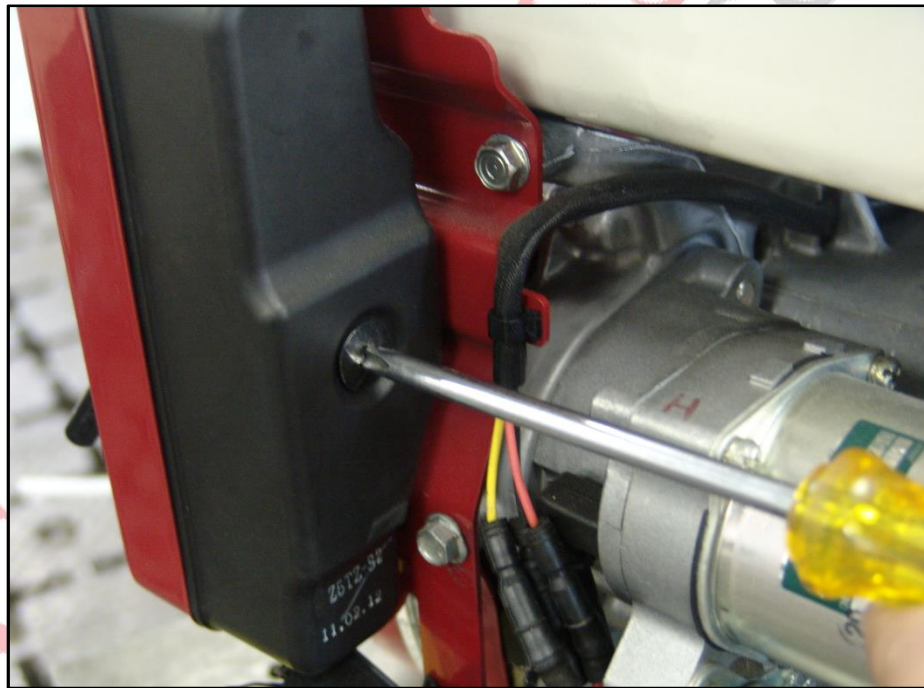

Figure 3

Installation (continued)

- b) Remove the black plastic cover from the back of the key switch box. Locate the black rectangular rectifier diode. It is on the side closest to the engine. Gently pry back the white plastic retainer clip on top of the diode closest to the key switch end and remove the diode. See Figure 4



Figure 4

- c) Replace the black plastic cover on the back of the key switch box. Insure rubber wire grommet is installed correctly in the slot.
- d) Tighten Phillips head screw.
- 4) Care should be taken when routing battery leads to insure that the leads are properly supported and insulated.
- 5) The positive lead should be color coded RED and all connections should be enclosed by non-conducting covers. See Figure 2
- 6) The negative lead should be connected directly to the Honda engine using one of the four 3/8+ diameter mounting foot studs.
- 7) Electrical connections should be regularly inspected to insure that they are clean and tight.

Installation (continued)



Do not install isolating valves between compressor outlet and air receiver. This will cause excessive pressure if valve is closed, and cause injury and equipment damage.



Always use an air pressure regulating device at the point of use. Failure to do so can result in injury or equipment damage.



- **Do not install in an area where ambient temperature is below 32°F or above 104°F.**
- **Do not install unit in an area where air is dirty and/or chemical laden.**

AIR LINE PIPING

Connection to air system should be of the same size, or larger, than discharge pipe out of unit. The table gives recommended minimum pipe sizes. A union connection to the unit and water drop leg is recommended. Install a flexible connector between the discharge of the unit and the air piping. Piping should be periodically inspected for leaks using a soap and water solution for detection on all pipe joints. Air leaks waste energy and are expensive.

**Minimum Pipe Sizes For Compressor Air Lines
(Based on clean Smooth Schedule 40 Pipe)**

MODEL	25'	50'	100'	200'	300'
R15B	3/4" (1")	3/4" (1")	3/4" (1")	1" (1-1/4")	1" (1-1/4")
R30D	3/4" (1-1/4")	1" (1-1/4")	1" (1-1/4")	1" (1-1/2")	1" (1-1/2")

Values in () are for duplex unit.



Never use plastic pipe or improperly rated metal pipe. Improper piping material can burst and cause injury or property damage.

Air Receiver Installation

Vibration isolator pads can be purchased from your local authorized distributor. Installation hardware items (studs, screws, nuts, shims) are not provided. It is the compressor owner's responsibility to provide a suitable foundation and isolator installation.



Do not tighten the anchor screws/nuts down completely – this will result in undesirable stress on the tank foot. This can cause abnormal vibration and possible cracking of the air receiver, resulting in injury or equipment damage.

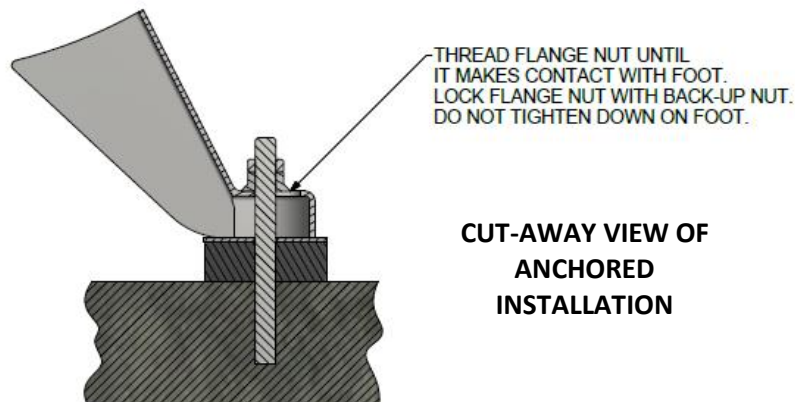
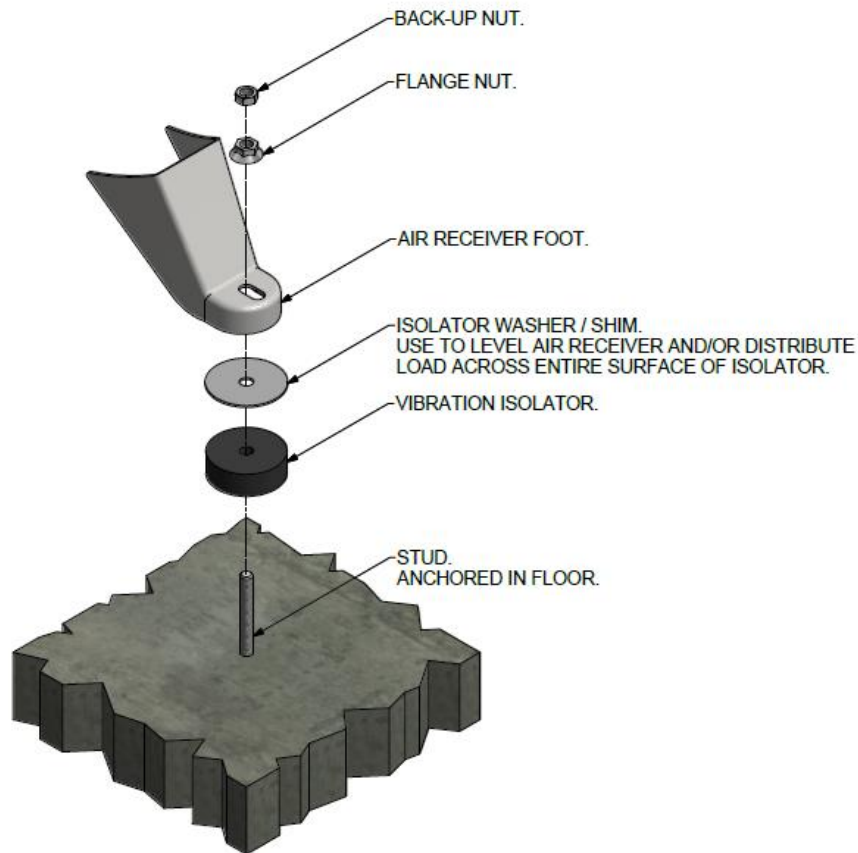

CUT-AWAY VIEW OF ANCHORED INSTALLATION

TEN011442-00
(Ref. Drawing)

Operation

This compressor has been inspected, thoroughly tested and approved at the factory. For this unit to give long satisfactory service it must be installed and operated properly. This compressor has been designed for an 80%/ON – 20%/OFF duty cycle.

Engine Drive units are equipped with a pilot valve and head unloaders to provide continuous run capabilities. The pilot valve acts as an automatic air switch allowing air to flow from the receiver to the head unloader mechanism, thus actuating it. The pilot valve senses receiver pressure. When the receiver pressure reaches the cut-out pressure setting of the pilot valve, the pilot valve opens and air is released to the unloader mechanism. The compressor stops compressing air and runs unloaded until the cut-in pressure setting of the pilot valve has been reached. At this time air is released from the unloader mechanism and the compressor starts compressing again.

INITIAL START UP

1. Inspect unit for any visible signs of damage that would have occurred in shipment or during installation.
2. Check compressor oil level. Add oil as required. See “Compressor Oil Specifications” Section.
NOTE: Do not mix oil type, weights, or brands.
3. Check engine oil level. Add oil as required. Consult engine manual for oil specifications.
4. Close receiver discharge ball valve.
5. Flip toggle lever on pilot valve to the “Manual Unload” position. See Figure 5.

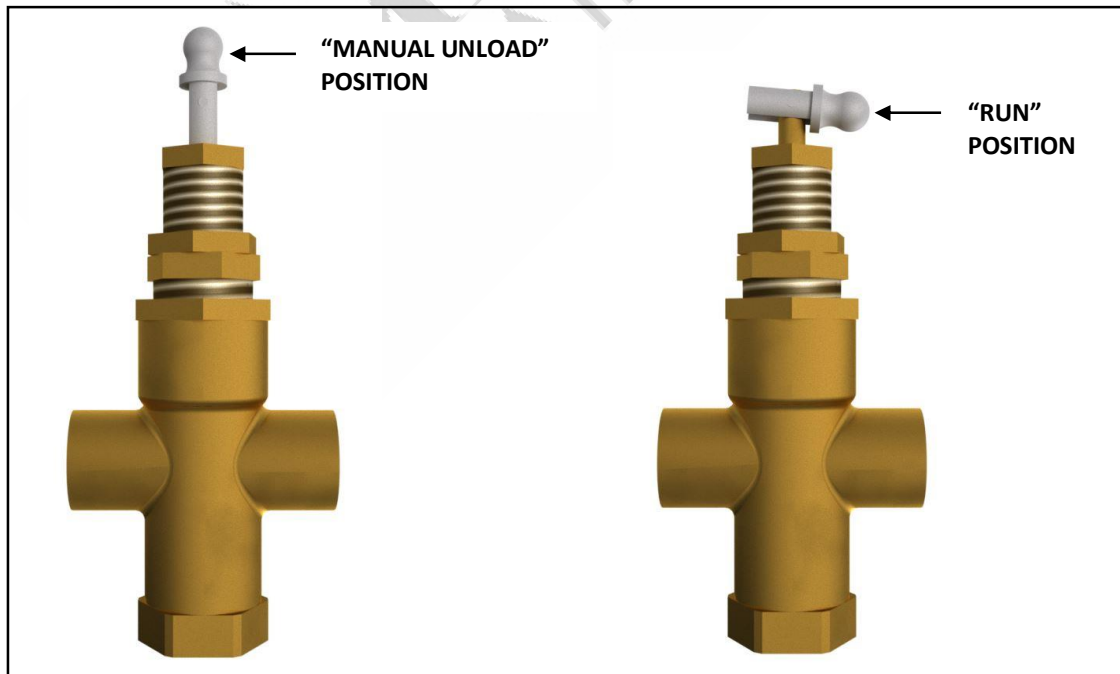

Figure 5

Operation (continued)

6. Start engine. Allow engine to warm up.
7. Flip toggle lever on pilot valve to the “Run” position. See Figure 5.
8. With receiver ball valve closed, let the machine pump up to operating pressure.
9. Check for proper operation of the head unloaders.
 - a. When the air receiver pressure reaches the cut-in setting of the pilot valve, the head unloaders will activate. The air compressor continues to run, but air compression is stopped.
 - b. Open the receiver ball valve slowly, allowing pressure in the receiver to drop.
 - c. When the air receiver pressure drops to the cut-out setting of the pilot valve, the head unloaders will de-activate. Air compression will resume.
 - d. Repeat steps a. thru c. three times.
10. Check for proper operation of any options.
11. When the initial run period has shown no operating problems, shut unit down and recheck oil level. Add oil if needed.
12. Open receiver ball valve. The air compressor unit is now ready for use.

DAILY STARTING

1. Check compressor and engine oil level.
2. Drain liquid from receiver.
3. Close receiver outlet valve.
4. Flip toggle lever on the pilot valve to the “Manual Unload” position. See Figure 5.
5. Start engine. Allow engine to warm up.
6. Flip toggle level on pilot valve to “Run” position. See Figure 5.
7. When unit reaches operation pressure, open receiver outlet valve.

Compressor Oil Specifications

Compressors are factory filled with CHAMPLUB hydrocarbon-based recip lubricant. This is an ISO 100 non-detergent industrial lubricant with rust and oxidation inhibitors specially formulated for reciprocating compressors. It is recommended this compressor be maintained using this oil for ambient temperatures above 32°F.

CHAMPLUB synthetic is a premium grade diester based synthetic lubricant providing excellent performance in high temperature applications.

Do not mix oil types, weights or brands.

Emulsification of oil (white milky substance) indicates unsafe accumulation of moisture and may be evidence compressor is oversized for application. Failure to promptly consult your local distributor, or Champion Customer Service, can be grounds to deny warranty.

BREAK-IN PERIOD:

1. Compressor must run for a 100 hour break-in period using ChampLub ISO 100 lubricant.
2. During the first 100 hours of compressor operation, a careful and regular check of the oil level should be made. Maintain oil level at the full line.
3. After 100 hours of operation, thoroughly drain existing oil from crankcase.
4. Add a full charge of CHAMPLUB ISO 100 lubricant.

CHANGING TO SYNTHETIC LUBRICANT

(Applies to diester based synthetic lubricant only)

If changing to synthetic lubricant, the following steps must be completed.

1. Compressor must run for a 100 hour break-in period using CHAMPLUB ISO 100 lubricant.
2. After 100 hours of operation, thoroughly drain existing oil from crankcase.
3. Add a full charge of CHAMPLUB SYNTHETIC lubricant.
4. Run compressor for 200 hours.
5. Stop compressor and thoroughly drain the synthetic lubricant.
6. Add a full charge of CHAMPLUB SYNTHETIC lubricant.
7. Compressor is now ready to run for extended period before next lubricant change. Maintain oil level at the full line.

Compressor Oil Specifications (continued)

LUBRICANTS

CHAMPLUB ISO 100

DESCRIPTION	PART NUMBER
1 – Quart Case (12/case)	P09479A
1 – Gallon Case (4/case)	P08909A
5 – Gallon Pail	P08908A
55 – Gallon Drum	P08907A

CHAMPLUB SYNTHETIC

DESCRIPTION	PART NUMBER
1 – Quart Case (12/case)	P13179A
1 – Gallon Case (4/case)	P13180A
5 – Gallon Pail	P11506A
55 – Gallon Drum	P13181A



Compressed Air Advisors, Inc.

Phone: 877.247.2381

info@compressedairadvisors.com

www.compressedairadvisors.com

Guide to Maintenance

For Service contact an authorized Champion distributor. To obtain reliable and satisfactory service, this unit requires a consistent preventive maintenance schedule. Maintenance schedule pages are included in the back of this manual to aid in keeping the proper records.



Before performing any maintenance function, be sure all air pressure in unit is relieved. Failure to do this may result in injury or equipment damage.



Never add fuel to the fuel tank of a hot engine. Spilled fuel may ignite and cause injury or equipment damage.



Do not exceed 15 PSIG nozzle pressure when cleaning element parts with compressed air. Do not direct compressed air against human skin. Serious injury could result. Never wash elements in fuel oil, gasoline or flammable solvent.



Never operate unit without belt guard in place. Removal will expose rotating parts which can cause injury or equipment damage.



Valves must be reinstalled in original position. Valve gaskets should be replaced each time valves are serviced.

ENGINE: For service, refer to separate engine manual.

PRESSURE RELIEF VALVE: The pressure relief valve is an automatic pop valve. Each valve is properly adjusted for the maximum pressure permitted by tank specifications and working pressure of the unit on which it is installed. If it should pop, it will be necessary to drain all the air out of the tank in order to reseal properly. Do not adjust.

TANK DRAIN VALVE: Drain valve is located at bottom of tank. Open drain valve daily to drain condensation. Do not open drain valve if tank pressure exceeds 25 PSIG.

Guide to Maintenance (continued)

PILOT VALVE: The pilot valve actuates the head unloader mechanism to provide a means of stopping or starting the compression of air by the compressor without stopping or starting the engine.



The pilot valve is pre-set from the factory, according to the order specification. Only a certified field service technician should make adjustments to the pilot valve.

PILOT VALVE PRESSURE ADJUSTMENT

Proceed with the following instructions while compressor is running:

1. Loosen locknut (4) and back off several turns. Do not turn differential pressure adjustment nut (3).
2. Check reading on the tank pressure gauge. Set the compressor maximum pressure by turning threaded cap (1) clockwise to increase pressure or counter clockwise to decrease pressure.
3. After pressure is set, tighten locknut (4). Be careful not to move threaded cap (1).

PILOT VALVE DIFFERENTIAL PRESSURE ADJUSTMENT

Proceed with the following instructions while compressor is running:

1. Loosen locknut (2) and back off several turns.
2. Check reading on the tank pressure gauge. Set the pressure to 30 psig differential (unload at 170 psig, reload at 140 psig). Turn nut (3) clockwise to increase differential pressure or counterclockwise to decrease differential pressure.
3. After pressure is set, tighten locknut (2). Be careful not to move nut (3).

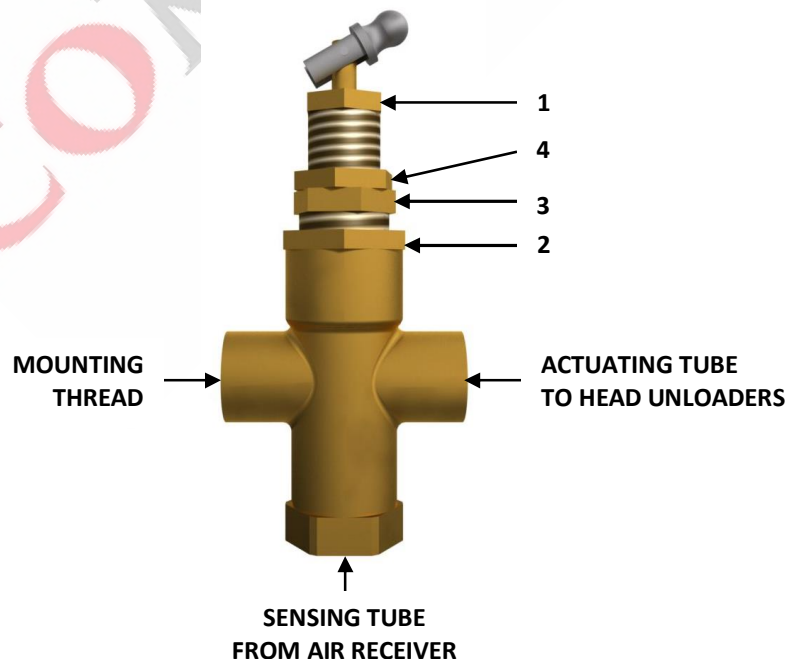

Guide to Maintenance (continued)

COMPRESSOR VALVES: If compressor fails to pump air or seems slow in filling up tank, disconnect unit from power source and remove valves and clean thoroughly, using compressed air and a soft wire brush. After cleaning, exceptional care must be taken that all parts are replaced in exactly the same position. All joints must be tight or the compressor will not function properly. When all valves are replaced and connections are tight, close ball valve at tank outlet for final test. Valve gaskets should be replaced each time valves are removed from pump.

CENTRIFUGAL UNLOADER AND UNLOADER PRESSURE RELEASE VALVE: The centrifugal unloader is operated by two governor weights. It is totally enclosed and lubricated from the crankcase of the compressor. When compressor starts, the governor weights automatically open, compressing the main spring, allowing the unloader pressure release valve to close. When the compressor stops, the main spring returns the governor weights to normal position, opening the unloader pressure release valve and unloading the compressor. This prevents overloading the motor when starting. If air continues to escape through the governor or unloader pressure release valve while operating, this is an indication that the unloader pressure release valve is not closing tightly and may be held open by a foreign substance which has lodged against the seat. In order to correct this, remove the governor release valve cap, allowing access to unloader pressure release valve spring and ball. Clean thoroughly and return parts in the same order in which they were removed. See Centrifugal Unloader section in parts list for diagram. Loose drive belts can also cause unloader to leak by preventing the compressor from reaching proper speed. (See "BELTS" page 23).

CHECK VALVE: The check valve closes when the compressor stops operating, preventing air from flowing out of the tank through the pressure release valve. After the compressor stops operating, if air continues to escape through the release valve, it is an indication that the check valve is leaking. This can be corrected by removing check valve and cleaning disc and seat. If check valve is worn badly, replace it.



Before removing check valve, be sure all air is drained out of tank and power is disconnected. Failure to do so may result in injury or equipment damage.

THE INTERSTAGE PRESSURE RELIEF VALVE is provided to protect against interstage over pressure and is factory set for maximum pressure of 75 PSIG. **DO NOT RESET.** If the pressure relief valve pops, it indicates trouble. Shut down the unit immediately and determine and correct the malfunction. Inspect the head valves. Serious damage can result if not corrected and can lead to complete destruction of the unit. Tampering with the interstage pressure relief valve or plugging the opening destroys the protection provided and voids all warranty.

COMPRESSOR LUBRICATION: Fill crankcase to proper level as indicated by oil sight gauge. Keep crankcase filled as required by usage. It is recommended that only Champlub recip lubricant be used. This is an ISO 100, non-detergent industrial oil with rust and oxidation inhibitors specially formulated for reciprocating compressors. Do not mix oil types, weights, or brands.

Guide to Maintenance (continued)

TORQUE VALUES:

Component	Fastener Size & Thread	Model	Torque
Governor Housing	3/8-16	R15	400 Inch-lb.
Governor Housing	7/16-20	R30	550 Inch-lb.
Cylinder Flange	7/16-20	R15, R30	400 Inch-lb.
Governor Spindle Screw	7/16-20	R15, R30	470 Inch-lb.
Rod Bolt	5/16-18	R15, R30	230 Inch-lb.
Manifold Cap Screw	3/8-16	R15, R30	200 Inch-lb.
Flywheel Pinch Bolt	1/2-13	R15, R30	600 Inch-lb.

COMPRESSED
AIR ADVISORS
Inc.

Guide to Maintenance (continued)

SETTING BELT TENSION

1. Proper setting of the belt tension requires a belt tension checker (part number TEN011452).
2. Measure the belt span.
3. On the belt tension checker, position the o-ring on the span scale at the measured belt span.
4. Position the o-ring on the deflection force scale to zero.
5. Place a straight edge across the outside diameters of the motor pulley and compressor flywheel.
6. Place the tension checker squarely on one belt at the center of the belt span. Apply a force on the plunger, perpendicular to the belt span until the bottom of the large o-ring is even with the bottom of the straight edge.
7. Remove the tension checker and read the force applied from the bottom of the small o-ring on the deflection force scale.
8. Compare the force you have applied with the values given in the table on page 25. The force should be between the minimum (used belt) and maximum (new belt) shown.
9. Make adjustments to the location of the motor to achieve proper tension.

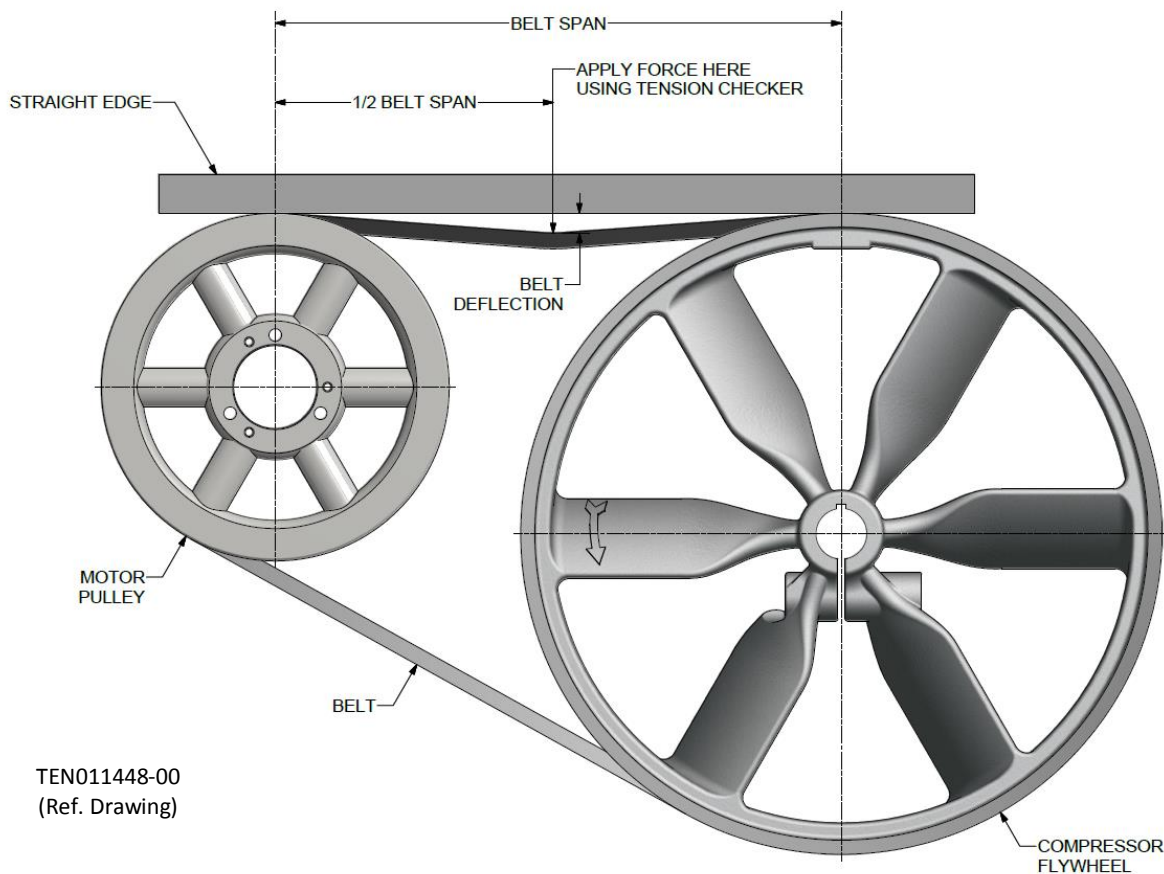

TEN011448-00
(Ref. Drawing)

Guide to Maintenance (continued)

BELT DEFLECTION FORCE

MODEL	H.P.	PSI	RPM	MOTOR PULLEY O.D.	BELT SECTION	BELT NUMBER	QTY OF BELTS	USED BELT DEFLECTION FORCE (lbs. min)	NEW BELT DEFLECTION FORCE (lbs. max)
R15 GAS	13, 14	175	1025	4.95	BX	71	2	3.6	5.2
R15 DIESEL	9.1, 9.3	175	870	4.35	BX	71	2	3.9	5.6
R30 GAS	20.5	175	765	4.35	B	80	2	5.0	7.1
R30 GAS	22.5	175	940	5.75	B	81	2	5.0	7.3

1. The values given in the “BELT DEFLECTION FORCE” table are calculated for nominal conditions and are provided for reference only. The required tension may vary due to application, manufacturing variances, component wear, etc. Drive belts must be kept tight enough to prevent slipping. If belts slip or squeak, they need to be tightened.
2. Belt cross-section can be found printed on the outside surface of the belt.



If belts are too tight, overload will be put on motor and motor bearings.

Maintenance Checklist

DAILY MAINTENANCE	
1	Check oil level of compressor. Add Champlub recip lubricant as required. See “Compressor Oil Specifications” Section. NOTE: Do not mix oil type, weight, or brands.
2	Check oil level of engine. Consult engine manual for manufacturer’s recommended oil.
3	Drain moisture from tank by opening tank drain valve located in bottom of tank. Do not open drain valve if tank pressure exceeds 25 PSIG.

WEEKLY MAINTENANCE	
1	Clean dust and foreign matter from cylinder head, motor, fan blades, air lines, intercooler, and tank.
2	Remove and clean intake air filters.
3	Check V-belts for proper alignment and tightness:
a	Remove belt guard bracket and open top half of belt guard to access compressor drive.
b	See “Setting Belt Tension” Section for details on how to check and set proper tension.
c	If necessary, loosen engine mounting plate fasteners. Use belt adjustment bolt at end of base plate to adjust belt tension.
d	Check the alignment of pulleys. The compressor flywheel and engine sheave should be aligned within $\pm 1/2^\circ$ with notched belts and $\pm 2^\circ$ with wrapped belts. Adjust if necessary.
e	Tighten engine mounting plate fasteners to secure engine on base.
f	Close top half of belt guard and re-install belt guard bracket

EVERY 90 DAYS OR 500 HOURS MAINTENANCE	
1	Change compressor crankcase oil and oil filter. Use only Champlub recip lubricant.
2	Check entire system for air leakage around fittings, connections, and gaskets, using soap solution and brush.
3	Tighten nuts and capscrews as required. See “Torque Values” section.
4	Check and clean compressor valves. Replace valves when worn or damaged. Replace valve gaskets after each inspection.
5	Pull ring on all pressure relief valves to assure free movement.



Troubleshooting Chart



Always shut off unit and relieve all pressure from air tank before performing any maintenance. Failure to do so may result in equipment damage or injury.

Never operate unit without belt guard in place.

Troubleshooting Chart

Symptom	Possible Cause(s)	Corrective Action
Engine will not start.	<ol style="list-style-type: none"> 1. No fuel in fuel tank. 2. High tank pressure. 3. Refer to separate engine manual for other causes. 	<ol style="list-style-type: none"> 1. Add fuel 2. Reduce tank pressure to 130 PSIG or less.
Tank pressure builds up slowly.	<ol style="list-style-type: none"> 1. Air leaks. 2. Dirty air filter. 3. Defective compressor valves 	<ol style="list-style-type: none"> 1. Tighten fittings. 2. Clean or replace. 3. Install new valves.
Tank pressure builds up quickly.	<ol style="list-style-type: none"> 1. Excessive water in tank. 	<ol style="list-style-type: none"> 1. Drain tank.
Discharge pressure relief valve pops off while compressor is running.	<ol style="list-style-type: none"> 1. Wrong pressure switch setting. 2. Defective ASME relief valve. 	<ol style="list-style-type: none"> 1. Adjust to correct setting. 2. Replace valve. <p> Warning – Relieve tank pressure before servicing.</p>
Compressor will not unload	<ol style="list-style-type: none"> 1. Wrong pilot valve setting. 2. Defective pilot valve. 3. Lack of air to pilot valve. 	<ol style="list-style-type: none"> 1. Adjust to correct setting. 2. Replace pilot valve. 3. Check piping from tank to pilot valve for leaks
Excessive belt wear.	<ol style="list-style-type: none"> 1. Pulley out of alignment. 2. Belts too tight or too loose. 	<ol style="list-style-type: none"> 1. Realign motor pulley. 2. Adjust belt tension.
Compressor runs hot.	<ol style="list-style-type: none"> 1. Improper flywheel rotation 2. Defective compressor valves. 3. Dirty air filter. 4. Dirty cylinder and/or intercooler. 	<ol style="list-style-type: none"> 1. Check for correct rotation. (Counter clockwise when viewed from drive side.) 2. Install new valve assembly. 3. Clean or replace. 4. Clean cylinder fins and/or intercooler.
Interstage pressure relief valve pops off.	<ol style="list-style-type: none"> 1. Defective compressor valves. 2. Improper valve installation. 	<ol style="list-style-type: none"> 1. Install new valves. 2. Verify proper valve placement.
Excessive oil consumption.	<ol style="list-style-type: none"> 1. Dirty air filter. 2. Wrong oil viscosity. 3. Oil leaks. 4. Worn piston rings. 5. Scored cylinder 	<ol style="list-style-type: none"> 1. Clean or replace. 2. Refill with proper viscosity oil. 3. Tighten bolts. Replace gaskets. 4. Replace rings. 5. Replace cylinder.
Air escapes from centrifugal unloader when unit is running	<ol style="list-style-type: none"> 1. Centrifugal unloader release valve dirty or defective. 	<ol style="list-style-type: none"> 1. Clean or replace valve
Air escapes from centrifugal unloader when unit is stopped.	<ol style="list-style-type: none"> 1. Check valve stuck in open position. 	<ol style="list-style-type: none"> 1. Replace check valve. <p> Warning – Relieve tank pressure before servicing.</p>



* C Q F 3 4 7 4 V E R 0 0 *
CQF3474VER00

COMPRESSED AIR ADVISORS

Inc.

Compressed Air Advisors, Inc.

Phone: 877.247.2381

info@compressedairadvisors.com

www.compressedairadvisors.com

COMPRESSED
AIR ADVISORS
Inc.

CHAMPION

For additional information, contact your local representative or visit:
www.championpneumatic.com/contactus.aspx
©2018 Gardner Denver, Inc. Printed in U.S.A.



Please recycle after use.