



# MANUAL USE AND MAINTENANCE

SILENCED SCREW ROTARY COMPRESSOR UNITS

**HP 20-25-30-40 KW 15-18,5-22-30**

Code	
9828093237	00
Edition 07/2018	

**THIS MACHINE MUST BE CONNECTED TO TWO DIFFERENT POWER SUPPLIES: THREE-PHASE SUPPLY FOR THE COMPRESSOR SINGLE-PHASE SUPPLY FOR THE DRYER**

**READ THIS MANUAL CAREFULLY BEFORE CARRYING OUT ANY OPERATIONS ON THE COMPRESSOR UNIT.**

**WARNING: ALWAYS WAIT FOR FIVE MINUTES BEFORE REMOVING THE FRONT COVER (INSTRUMENT PANEL). USE A SPECIFIC INSTRUMENT TO CHECK THAT THERE ARE NO DANGEROUS VOLTAGES BEFORE PERFORMING OPERATIONS ON THE MOTOR.**

CONTENTS	
PART A: INFORMATION FOR THE USER	PART B: INFORMATION RESERVED FOR TECHNICALLY SKILLED PERSONNEL
1.0 GENERAL CHARACTERISTICS	20.0 STARTING UP
2.0 INTENDED USE	21.0 GENERAL ORDINARY MAINTENANCE REQUIRES TRAINED PERSONNEL
3.0 OPERATION	22.0 CHANGING THE OIL
4.0 GENERAL SAFETY STANDARDS	23.0 CHANGING THE OIL SEPARATING FILTER
5.0 DESCRIPTION OF DANGER SIGNALS	24.0 BELT TENSION
6.0 DANGER ZONES	25.0 REPLACING THE ELECTRIC MOTOR
7.0 SAFETY DEVICES	26.0 OLEOPNEUMATIC DIAGRAM
8.0 POSITION OF PLATES	27.0 CALIBRATIONS FOR DRYER
9.0 COMPRESSOR ROOM	
10.0 TRANSPORT AND HANDLING	<b>IMPORTANT: A COPY OF THE WIRING DIAGRAMS CAN BE FOUND INSIDE THE ELECTRIC PANEL OF THE COMPRESSOR.</b>
11.0 UNPACKING	
12.0 INSTALLATION	
13.0 DIMENSIONS AND TECHNICAL DATA	
14.0 MACHINE ILLUSTRATION	
15.0 ORDINARY MAINTENANCE TO BE DONE BY THE USER	
16.0 PERIODS OF INACTIVITY	
17.0 SCRAPPING THE UNIT	
18.0 LIST OF SPARE PARTS FOR ROUTINE MAINTENANCE	
19.0 TROUBLE-SHOOTING AND EMERGENCY REMEDIES	

**Compressed Air Advisors, Inc.**

Phone: 877.247.2381

info@compressedairadvisors.com

[www.compressedairadvisors.com](http://www.compressedairadvisors.com)

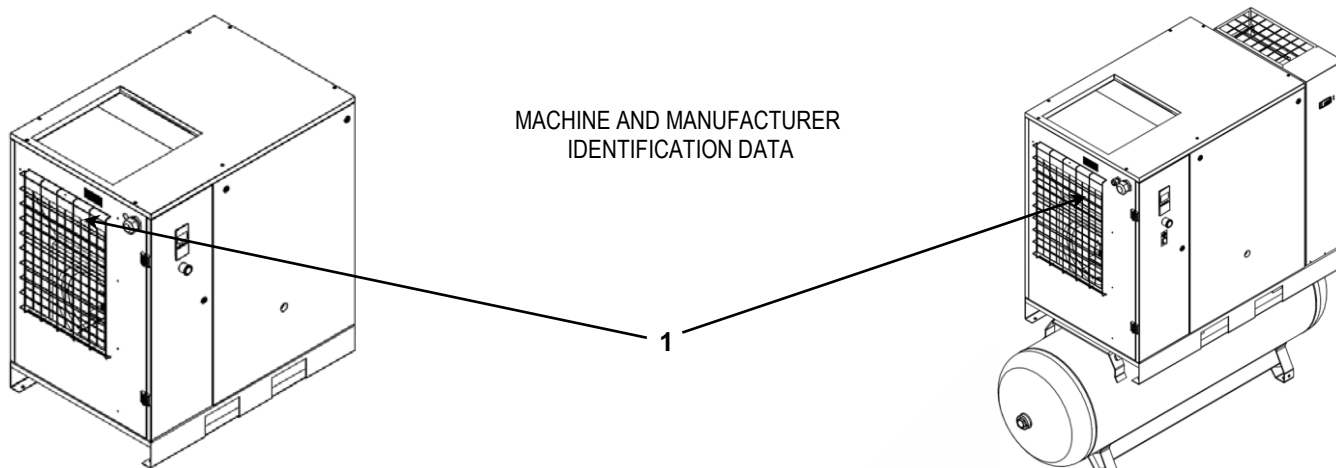

MACHINE AND MANUFACTURER IDENTIFICATION DATA

1) Position of the identification plate

## ADDRESSES OF ASSISTANCE CENTRES

In the event of breakdown or malfunction of the machine, switch it off and do not tamper with it. If repairs are needed, apply only to a technical assistance center approved by the manufacturer and insist on the use of original spare parts. Failure to comply with the above may endanger the safety of the machine.

### INTRODUCTION

Keep this manual with care for future consultation; the use and maintenance manual is an integral part of the machine. Read this manual carefully before carrying out any operations on the compressor unit.

The installation of the compressor unit and all operations involving it must be performed in conformity with the regulations in force concerning electric plants and personal safety.

## CHARACTERISTICS AND SAFETY PRECAUTIONS



### MACHINE WITH AUTOMATIC START

Lock Out – Tag out (LOTO): Open the power-isolating switch and lock it with a personal lock. Tag the power-isolating switch with the name of the service technician.



BEFORE REMOVING THE PROTECTIVE GUARDS TO CARRY OUT ANY MAINTENANCE ON THE MACHINE, SWITCH OFF THE ELECTRIC POWER SUPPLY AND DISCHARGE THE RESIDUAL PRESSURE INSIDE THE UNIT.

ALL WORK ON THE ELECTRIC PLANT, HOWEVER SLIGHT, MUST BE CARRIED OUT BY PROFESSIONALLY SKILLED PERSONNEL.

THIS MACHINE IS NOT SUITABLE FOR EXTERNAL INSTALLATION

THIS MACHINE CORRESPOND TO THE ESSENTIAL SAFETY REQUIREMENTS FORESEEN FROM THE EUROPEAN STANDARD (2006/42 CE).

*THE LUBRICATING LIQUIDS AND OTHER EVENTUAL FLUIDS MUST NOT BE DISCHARGED IN THE ENVIRONMENT. THESE POLLUTING AND HAZARDOUS PRODUCTS MUST COMPULSORY BE DISPOSED BY CHARGING AUTHORISED AND SPECIALISED FIRMS ACCORDING TO THE DIFFERENT TYPOLOGY OF PRODUCT.*

*DIFFERENTIATE THE COMPRESSOR COMPONENTS ACCORDING TO THE DIFFERENT CONSTRUCTION MATERIALS (PLASTIC, COPPER, IRON, OIL FILTER, AIR FILTER ECC...)*

The manufacturer does not accept responsibility for damage caused as a result of negligence or failure to abide by the instructions given above.

## AIR RECEIVER AND SAFETY VALVE:

- To limit internal corrosion, which could compromise the safety of the compressed air tank, **the condensation that is produced must be discharged at least once a day**. If an automatic drain fitted to the air receiver is present, it is necessary to check that it is working correctly every week and repair it if necessary.
- **The thickness of the receiver must be checked every year and also in accordance with legislation in force in the country where the receiver is installed.**
- **The tank cannot be used and must be replaced if the thickness falls below the minimum level given in the instruction documents for the tank.**
- The tank can be used within the temperature limits given in the conformity declaration.
- **The safety valves of the air receiver and oil receiver must be checked every year and replaced in accordance with legislation in force.**

**NOT RESPECTING THE ABOVE MENTIONED PRESCRIPTION CAN RESULT IN AIR RECEIVER BURSTING HAZARD.**

The manufacturer does not accept responsibility for damage caused as a result of negligence or failure to abide by the instructions given above.

## 1.0 GENERAL CHARACTERISTICS

The compressor units use single-stage screw rotary air compressors with oil injection.

The central unit comprises:

compressor, dryer and steam trap if present, storage tank.

The system is self-bearing and does not require bolts or other devices to anchor it to the floor.

The unit is completely assembled in the factory; the necessary connections for setting it up are:

- connection to the power mains (see installation chapter)
- connection to the compressed air network (see installation chapter)

## 2.0 INTENDED USE

The compressor has been built to supply compressed air for industrial use.

The machine cannot be used in premises where there is a risk of fire or explosion or where work is carried out which releases substances into the environment which are dangerous with regard to safety (for example: solvents, inflammable vapors, alcohol, etc.).

In particular, the appliance cannot be used to produce air to be breathed by humans or used on direct contact with foodstuffs. These uses are allowed if the compressed air produced is filtered by means of a suitable filtering system (Consult the manufacturer for these special uses.) This appliance must be used only for the purpose for which it was specifically designed.

All other uses are to be considered incorrect and therefore unreasonable.

The Manufacturer cannot be held responsible for any damage resulting from improper, incorrect or unreasonable use.

## 3.0 OPERATION

### 3.1 OPERATION FOR COMPRESSOR

The electric motor and the compressor unit are coupled by means of a belt transmission.

The compressor unit takes in the outside air through the suction valve. The air taken in is filtered by pre-filter panel placed on the side conveyor external and by the filter cartridge fitted upstream from the suction valve. Inside the compressor unit, the air and the lubricating oil are compressed and sent to the oil separating tank where the oil is separated from the compressed air; the air is then filtered again by the oil separating cartridge to reduce the amount of suspended oil particles to a minimum. At this point the two flows (of oil and air) are sent to two separate coolers where they are cooled, using a flow of air taken from the environment by a special fan inside the machine.

The cooled oil returns to the circuit while the compressed air passes the using network.

### 3.2 OPERATION FOR DRYER

Dryer operation is described below. The gaseous refrigerant coming from the evaporator (4) is sucked by the refrigeration compressor (1) and it is pumped into the condenser (2). This one allows its condensation, eventually with the help of the fan (3); the condensed refrigerant passes through the dewatering filter (8) and it expands through the capillary tube (7) and goes back to the evaporator where it produces the refrigerating effect.

Due to the heat exchange with the compressed air which passes through the evaporator against the stream, the refrigerant evaporates and goes back to the compressor for a new cycle. The circuit is equipped with a bypass system for the refrigerant; this intervenes to adjust the available refrigerating capacity to the actual cooling load. This is achieved by injecting hot gas under the control of the valve (9): this valve keeps constant the pressure of the refrigerant in the evaporator and therefore also the dew point never decreases below 0 °C in order to prevent the condensate from freezing inside the evaporator.

The drier runs completely automatically; it is calibrated in the factory for a dew point of 3 °C and therefore no further calibrations are required.

### DRYER FLOW DIAGRAM

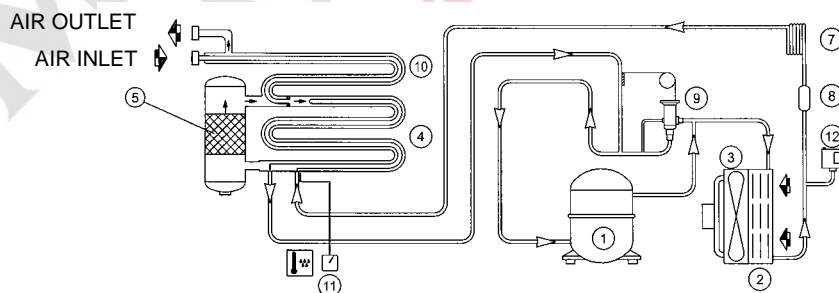

## 4.0 GENERAL SAFETY STANDARDS

The appliance may be used only by specially trained and authorized personnel.

Any tampering with the machine or alterations not approved beforehand by the Manufacturer relieve the latter of responsibility for any damage resulting from the above actions.

The removal of or tampering with the safety devices constitutes a violation of the European Standards on safety.

**ENSURE THAT THERE ARE DISCONNECTOR SWITCH AND FUSES UPSTREAM THE MACHINE. FOR DETAILS (SIZE AND TYPE) SEE WIRING/SERVICE DIAGRAM.**













**ALL WORK ON THE ELECTRIC PLANT, HOWEVER SLIGHT, MUST BE CARRIED OUT BY PROFESSIONALLY SKILLED PERSONEL.**



## 5.0 DESCRIPTION OF DANGER SIGNALS

FIG. 2

	1) FLUID EJECTION		6) HOT PARTS
	2) DANGEROUS ELECTRIC VOLTAGE		7) MOVING PARTS
	3) AIR NOT FIT FOR BREATHING		8) MOVING PARTS
	4) NOISE		9) MACHINE WITH AUTOMATIC START
	5) HIGH PRESSURE		10) PURGE EVERY DAY

## 5.1 DESCRIPTION OF COMPULSORY SIGNALS

	11) READ THE USE AND MAINTENANCE INSTRUCTIONS		
-----------------------------------------------------------------------------------	-----------------------------------------------	--	--

## 6.0 DANGERS ZONES

### 6.1 DANGERS ZONES FOR COMPRESSOR UNIT

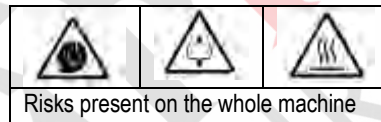
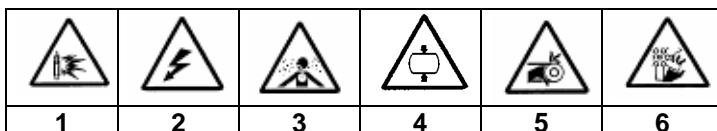
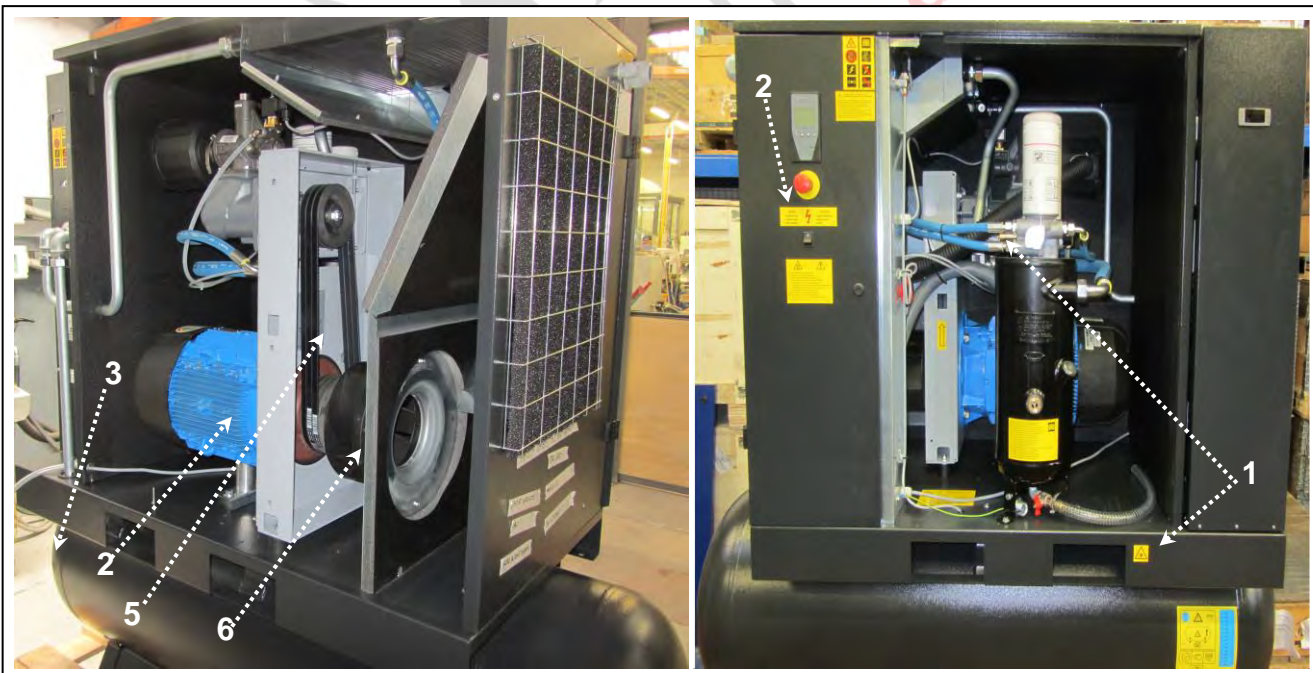
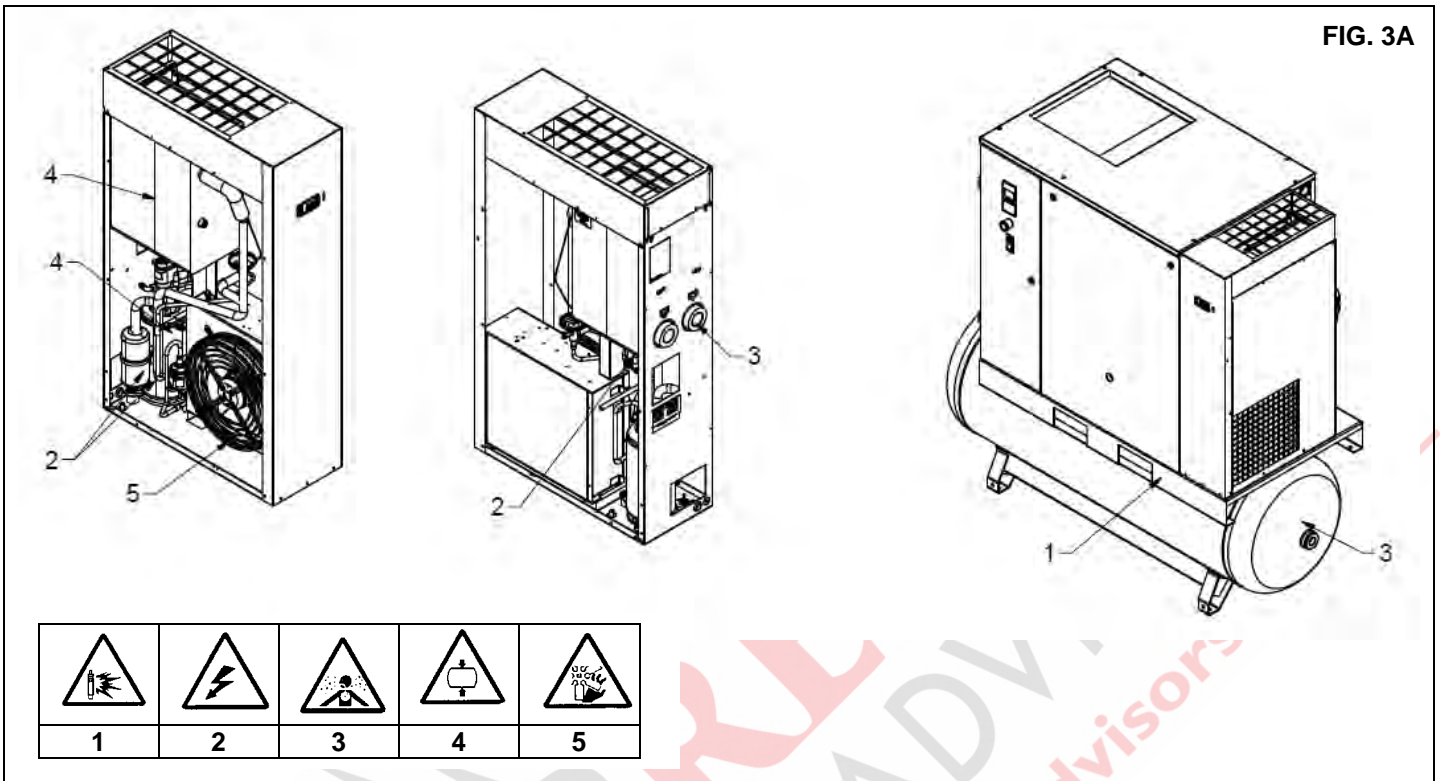
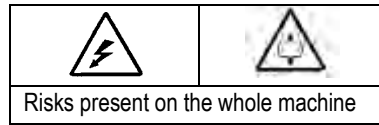

FIG. 3



## 6.2 DANGERS ZONES FOR DRYER UNIT AND TANK



## 7.0 SAFETY DEVICES

### 7.1 SAFETY DEVICES FOR SCREW COMPRESSOR (Fig. 4)

1) Safety screws	4) Emergency stop button with mechanical seal and rotation release.
2) Front panels and door to the electric panel, opened with a special key	5) Oil filling cap (with safety breather)
3) Fixed protection device - cooling fan	6) Safety valve
3) Fixed protection device - pulleys	

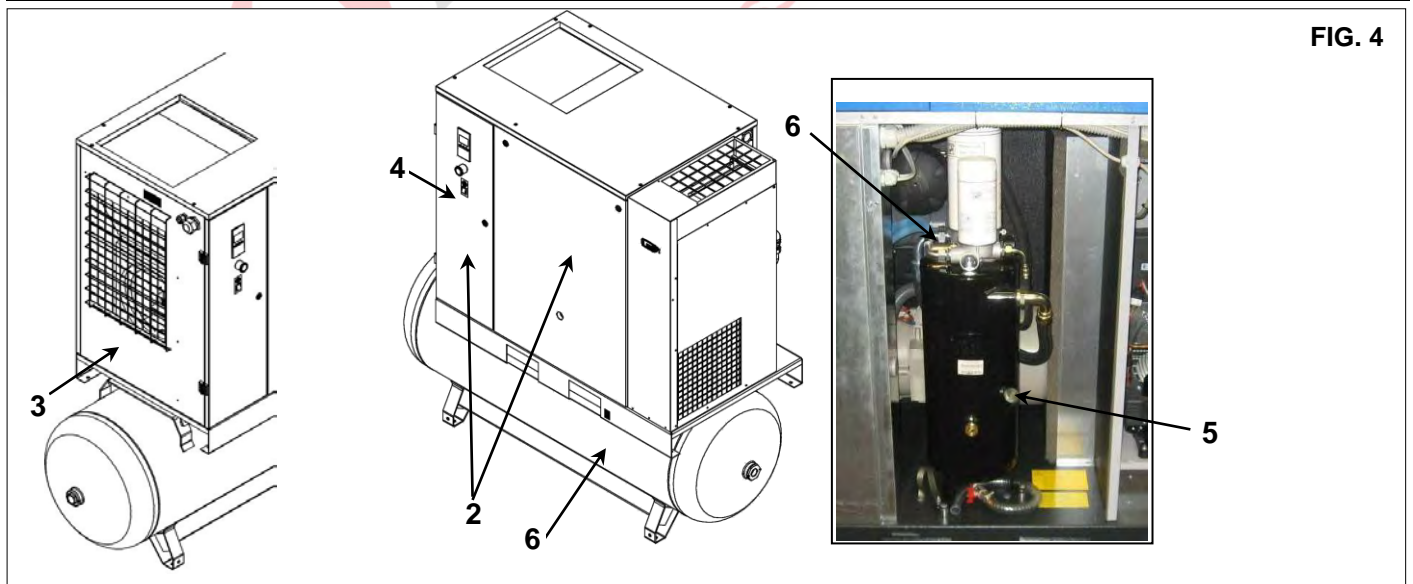

## 7.2 SAFETY DEVICES FOR DRIER UNIT AND TANK

1) Safety valve	3) Fan protection
2) Earth	4) Capacitor

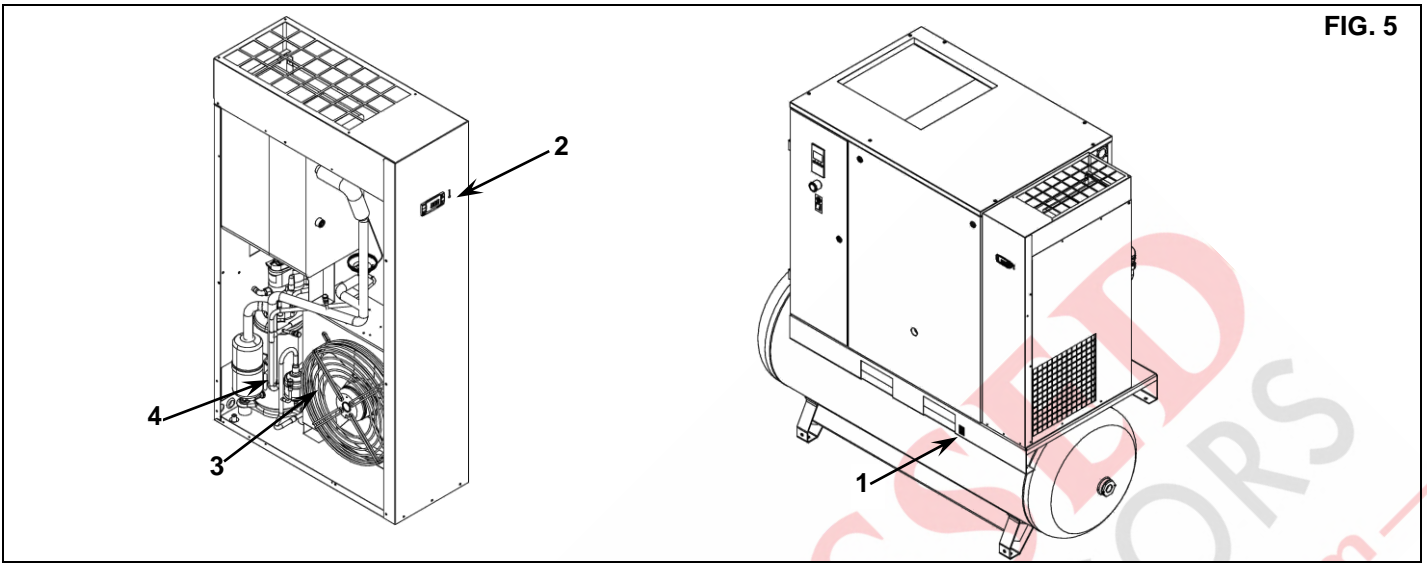

FIG. 5

## 8.0 POSITION OF PLATES

### 8.1 POSITION OF THE DANGER PLATES FOR COMPRESSOR UNIT

The plates fitted on the compressor unit are part of the machine; they have been applied for safety purposes and must not be removed or spoiled for any reason.

- 1) Dangers plate Code 2202260791
- 2) Plate "Machine with automatic start" 2202260791
- 3) Decal pulley guard Code 2203011600

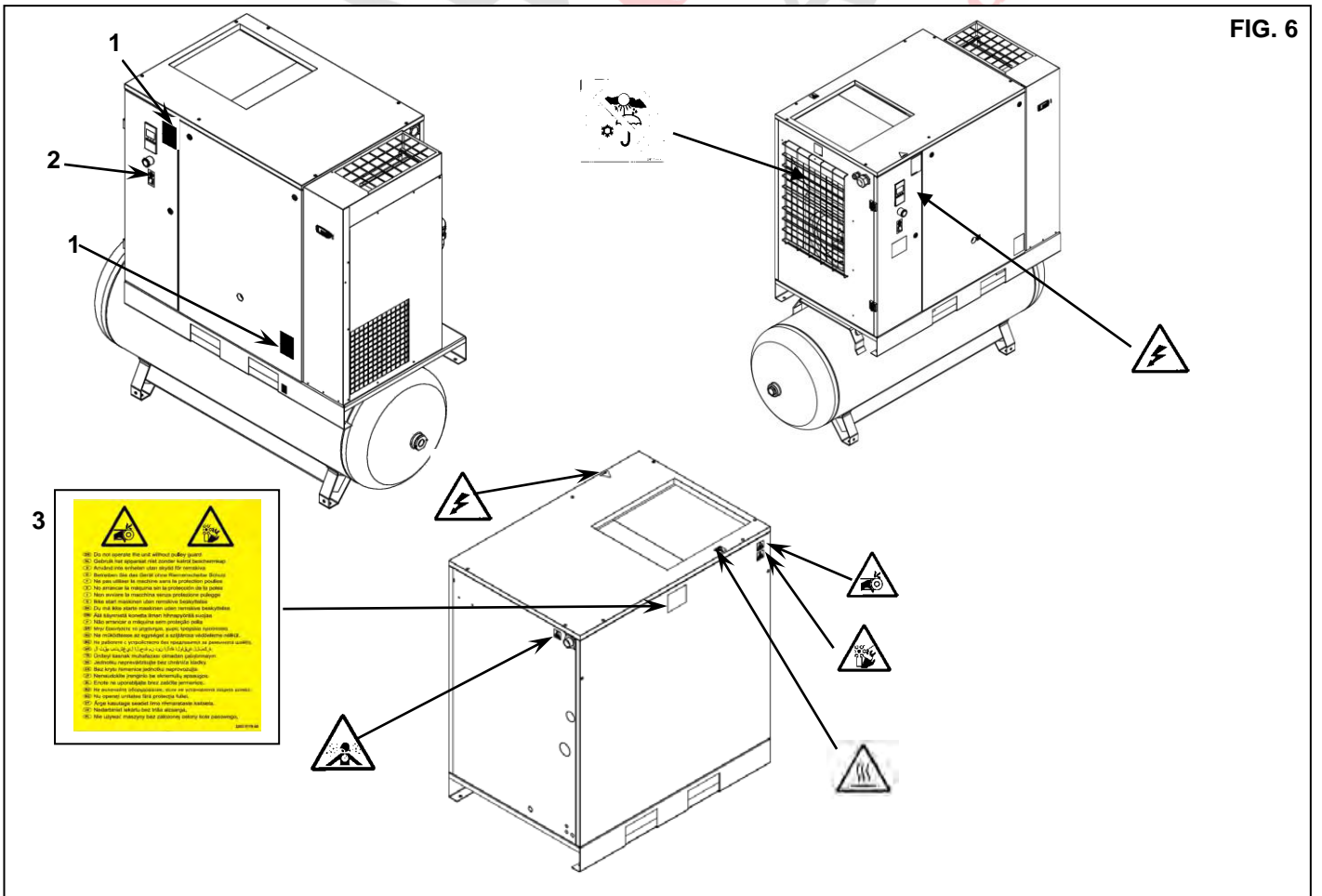

FIG. 6



## 8.2 POSITION OF THE DANGER PLATES FOR DRYER UNIT AND TANK

The plates fitted on the compressor unit are part of the machine; they have been applied for safety purposes and must not be removed or spoiled for any reason.

1) Dangers label Cod. 1079 9903 48

3) Label caution / attention Cod. 2202873104 / 2203054110

2) Label "Machine with automatic start" and decal warning 2202260791

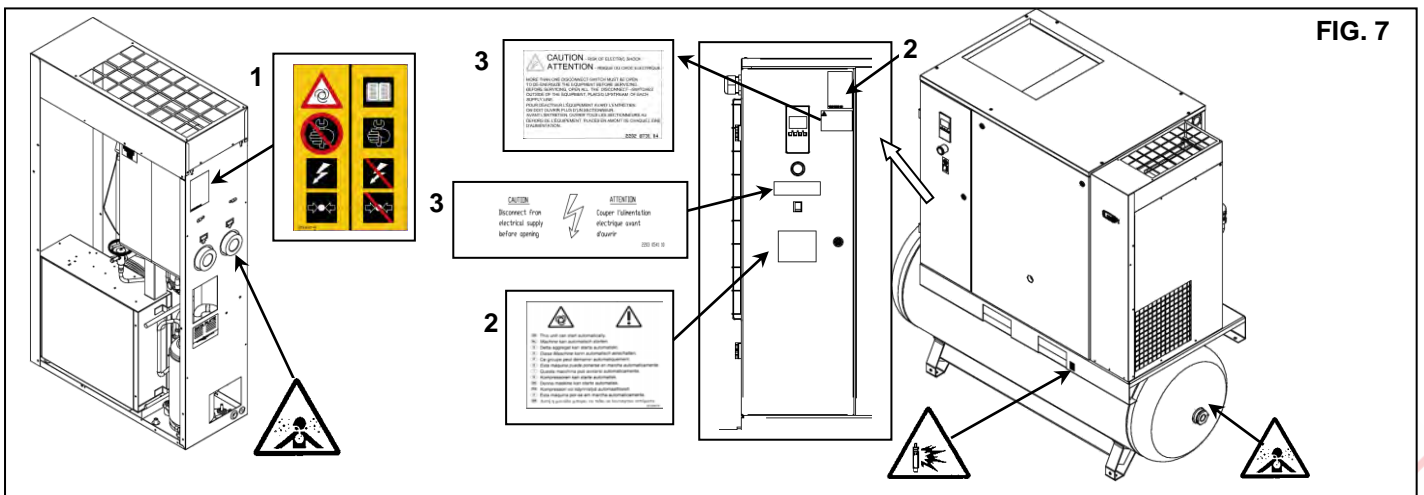

FIG. 7

## 8.3 POSITION OF THE DATA PLATE FOR COMPRESSOR UNIT

1) Identification plate

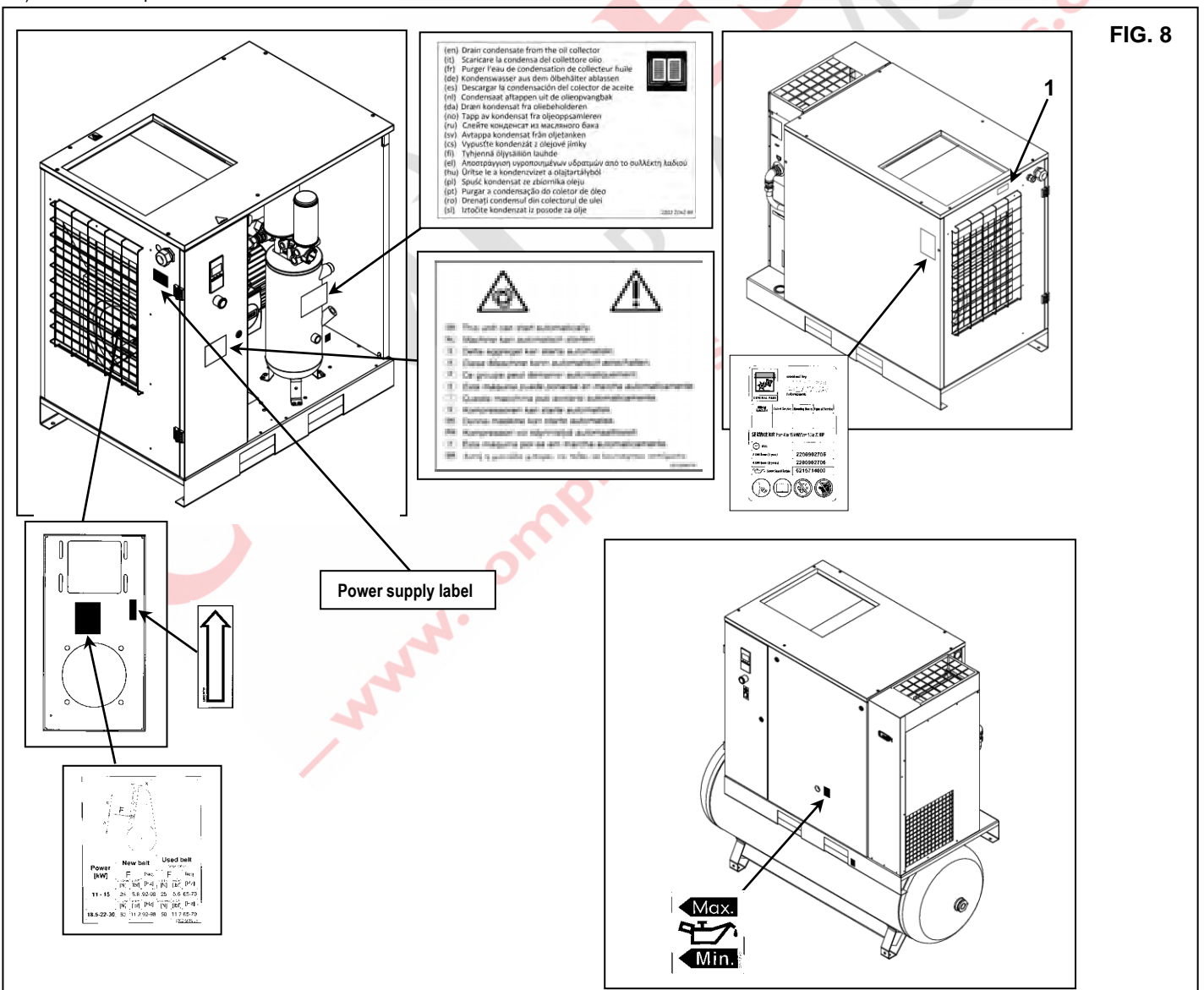
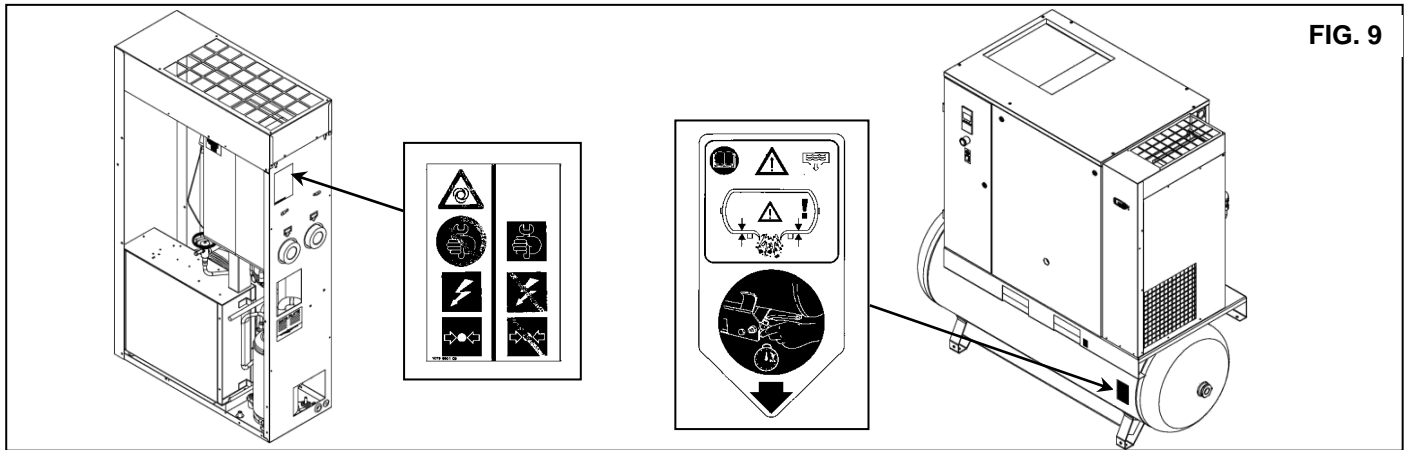

FIG. 8

## 8.4 POSITION OF THE DATA PLATE FOR DRYER – AIR RECEIVER



## 9.0 COMPRESSOR ROOM

### 9.1 FLOOR

The floor must be even and of industrial type; the total weight of the machine is shown in the Chap. 13.0 Remember the total weight of the machine when positioning it.

### 9.2 VENTILATION

When the machine is operating, the room temperature must not be higher than **40 °C** or lower than **2 °C**.

The volume of the room must be about **60 m<sup>3</sup>** the room must be provided with 2 openings for ventilation with a surface area of about **0,5 m<sup>2</sup>** each. The first opening must be in a high position to evacuate the hot air; the second opening must be low to allow the intake of external air for ventilation. If the environment is dusty, it is advisable to fit a filtering panel on this opening.

### 9.3 EXAMPLES OF VENTILATION OF THE COMPRESSOR ROOM

ATTENTION: Removable pipe to allow cleaning of the radiator.

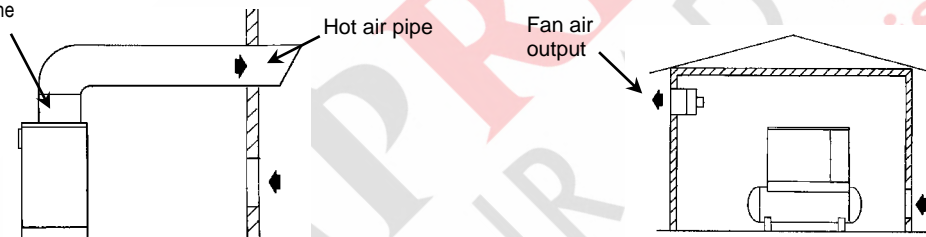

## 10.0 TRANSPORT AND HANDLING

The machine must be transported as shown in the following figures.

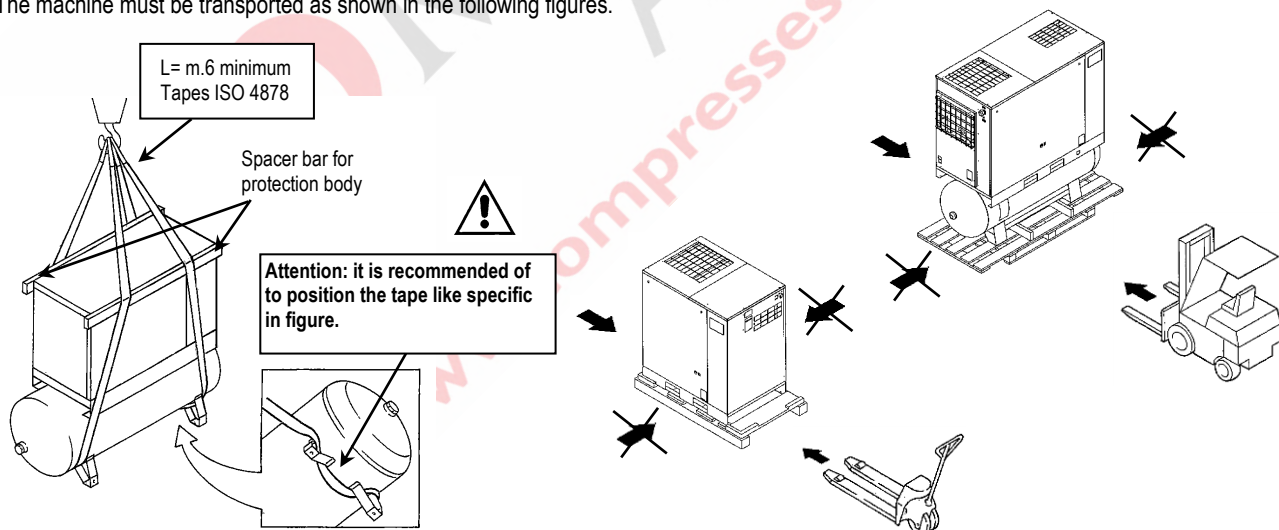

## 11.0 UNPACKING

After removing the packing, ensure that the machine is unbroken and that there are no visibly damaged parts.

If you are in doubt, do not use the machine but apply to the manufacturer technical assistance service or to your dealer. The packing material (plastic bags) must not be left within the reach of children or abandoned in the environment, as they are a potential source of danger and pollution. Dispose of these materials in the approved collection centres.



## 12.0 INSTALLATION

### 12.1 POSITIONING

After unpacking the equipment and preparing the compressor room, put the machine into position, checking the following items:

- Ensure that there is sufficient space around the machine to allow maintenance (see Fig. 12).

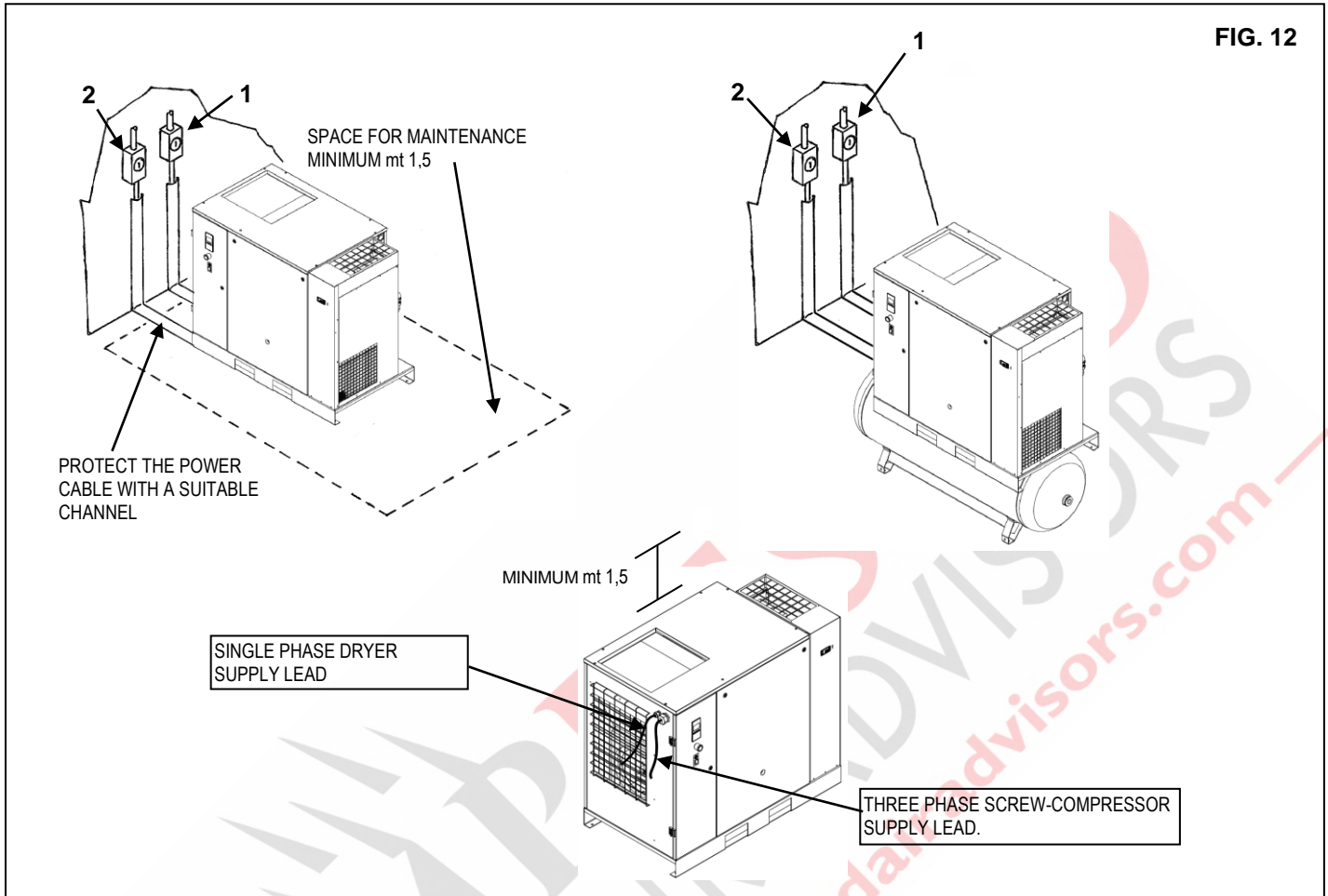

**ENSURE THAT THE OPERATOR CAN SEE THE WHOLE MACHINE FROM THE CONTROL PANEL AND CHECK THE PRESENCE OF ANY UNAUTHORIZED PERSONS NEAR THE MACHINE.**

### 12.2 ELECTRICAL CONNECTION

- Check that the supply voltage is the same as the value indicated on the machine data plate.
- Check the condition of the line leads and ensure that there is an efficient earth lead.
- **Ensure that there are disconnect switch and fuses upstream the machine (see Ref. 2 for compressor Ref. 1 for dryer Fig. 12). For details (size and type), see wiring/service diagram**
- Connect the machine power cables with the greatest care, according to the standards in force. These cables must be as indicated on the machine-wiring diagram.
- Connect the cables to the charging clamps on the electric panel and make sure they are properly tightened. After the first 50 working hours, check that the screws on the electric terminals are tight.

**ONLY PROFESSIONALLY SKILLED PERSONNEL MAY HAVE ACCESS TO THE ELECTRIC PANEL. SWITCH OFF THE POWER BEFORE OPENING THE DOOR OF THE ELECTRIC PANEL. COMPLIANCE WITH THE REGULATIONS IN FORCE CONCERNING ELECTRIC PLANTS IS FUNDAMENTAL FOR OPERATOR SAFETY AND FOR THE PROTECTION OF THE MACHINE.**



**CABLES, PLUGS AND ALL OTHER TYPE OF ELECTRIC MATERIAL USED FOR THE CONNECTION MUST BE SUITABLE FOR THE USE AND COMPLYING WITH THE REQUIREMENTS STATED BY THE REGULATIONS IN FORCE.**

The standard voltage configuration for the compressor is mentioned on the **data plate** of the machine.

**NEVER OPERATE THE COMPRESSOR ON A VOLTAGE OTHER DIFFERENT THAN SHOWN ON THE ELECTRIC CABINET. For tri-voltage machine follow the instructions in the electrical diagram (inside cubicle) to convert the operating voltage of the compressor for either 200V or 230V or 460V**

### 12.3 CONNECTION TO THE COMPRESSED AIR NETWORK

Fit a manual interception valve Ref. 1 between the machine and the compressed air network so that the compressor may be isolated during maintenance, operations (see figure 13).



**PIPES, FITTINGS AND CONNECTIONS USED FOR THE CONNECTION OF THE ELECTROCOMPRESSOR TO THE COMPRESSED AIR NETWORK MUST BE SUITABLE TO THE USE ACCORDING TO THE PRESCRIPTIONS OF THE REGULATIONS IN FORCE IN THE COUNTRY OF USE.**

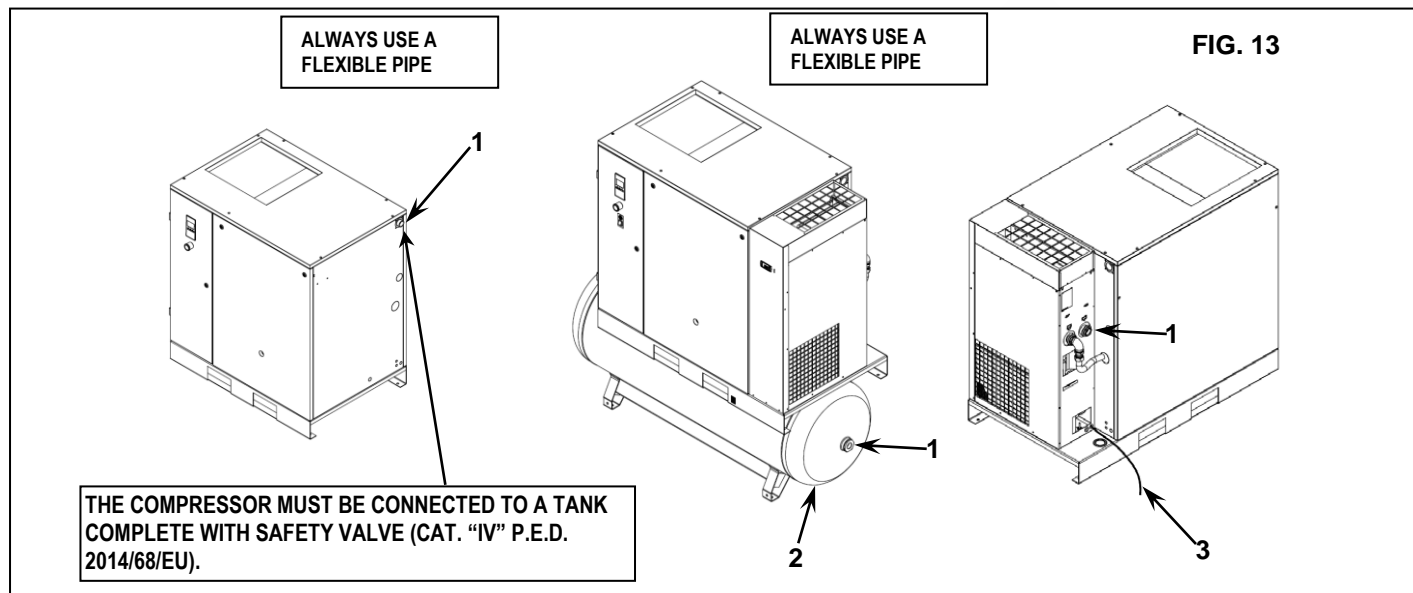

The manual drainage Ref. 2 the condensate automatic Ref. 3 Fig. 13, are led outside the machine with a flexible pipe that may be inspected. Drainage must comply with the local regulations in force.



**ALL DAMAGE DUE TO THE FAILURE TO COMPLY WITH THESE INDICATIONS CANNOT BE ATTRIBUTED TO THE MANUFACTURER AND MAY CAUSE INVALIDITY OF THE GUARANTEE CONDITIONS.**

### 12.4 STARTING UP

See part B of this manual, **Chapter 20.0**

### 13.0 DIMENSIONS AND TECHNICAL DATA

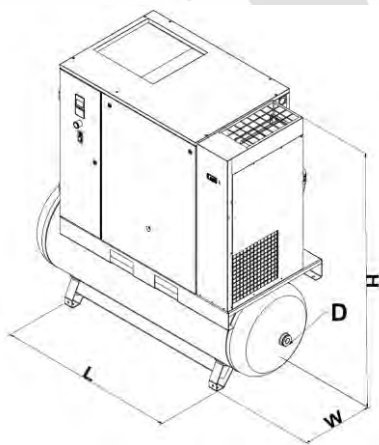

<i>Air receiver 500 LT.</i>				
HP 20-25-30-40 kW 15-18,5-22-30	Dimensions (mm)			Air connection
	L	W	H	D
	1904	780	1833	1"

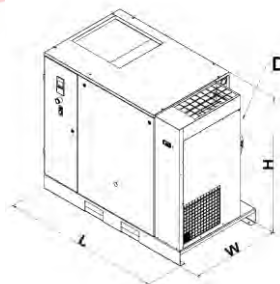

HP 20-25-30-40 kW 15-18,5-22-30	<i>With Dryer</i>			Air connection
	Dimensions (mm)			D
	L	W	H	D
	1400	780	1250	1"

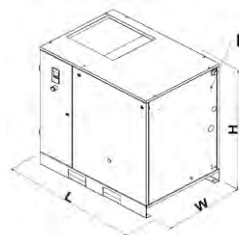

HP 20-25-30-40 kW 15-18,5-22-30	<i>Without Dryer</i>			Air connection
	Dimensions (mm)			D
	L	W	H	D
	1130	780	1250	1"

	Net weight Kg.									
	HP 20 kW 15		HP 25 kW 18,5		HP 30 kW 22		HP 40 kW30			
Weight (without / with) dryer	313	362	328	377	344	393	444	493		
With air receiver 500 l. Weight	537	588	545	603	561	619	-	-		

	HP 20 - kW 15			HP 25 - kW 18,5			HP 30 - kW 22			HP 40 - kW 30		
	7,5 Bar	9,5 Bar	12,5 Bar	7,5 Bar	9,5 Bar	12,5 Bar	7,5 Bar	9,5 Bar	12,5 Bar	7,5 Bar	9,5 Bar	12,5 Bar
Standard air capacity l/min.	3081	2810	2289	3604	3244	2761	4326	3971	3546	4668	3762	3486
Max. pressure bar	8	10	13	8	10	13	8	10	13	8	10	13
Noiose produce. DB(A)	67			69			70			71		
Power HP - KW	20 - 15			25 - 18,5			30 - 22			40 - 30		
Oil operation timer setting °C	110						110					
Oil loda kg.	9						12					

Type Dryer	Weight Kg.	Freon R 410A Kg.		Nominal Power W		Nominal Power W		Nominal Power W		Bar MAX. 
		50 Hz	60 Hz	50 Hz	60 Hz	50 Hz	60 Hz	50 Hz	60 Hz	
E8V	65		0,680		837		98		935	Bar 14
E8/9V	67		0.82		1344		96		1440	Bar 14

**Reference conditions:**

Ambient temperature 25 °C  
 Inlet air temperature 35 °C  
 Pressure 7 bar  
 Dew point in pressure 3 °C

**Limit conditions:**

Max. ambient temperature 46°C  
 Min. ambient temperature 1°C  
 Max. inlet air temperature 55°C  
 Max. working pressure 14 bar



## 14.0 MACHINE ILLUSTRATION

### 14.1 GENERAL LAYOUT FOR DRYER AND TANK

- |                                                |                               |
|------------------------------------------------|-------------------------------|
| 1 Air suction filter                           | 12 Oil discharge              |
| 2 Thermostatic valve                           | 13 Oil tank                   |
| 3 Oil filter                                   | 14 Pressure gauge tank        |
| 4 Air-oil cooler                               | 15 Control card               |
| 5 Filter panel                                 | 16 Safety valve (*)           |
| 6 Belt tightening system                       | 17 Condensate manual drainage |
| 7 Minimum pressure valve                       | 18 Electric motor             |
| 8 Air-oil separator with oil separating filter | 19 Screw compressor           |
| 9 Top-up or oil filling cap                    | 20 Suction unit               |
| 10 Control panel                               | 21 Air tank                   |
| 11 Oil gauge                                   |                               |

**\* IT IS FORBIDDEN TO TAMPERE WITH THE SETTING VALUES OF THE SAFETY VALVE**

FIG. 15

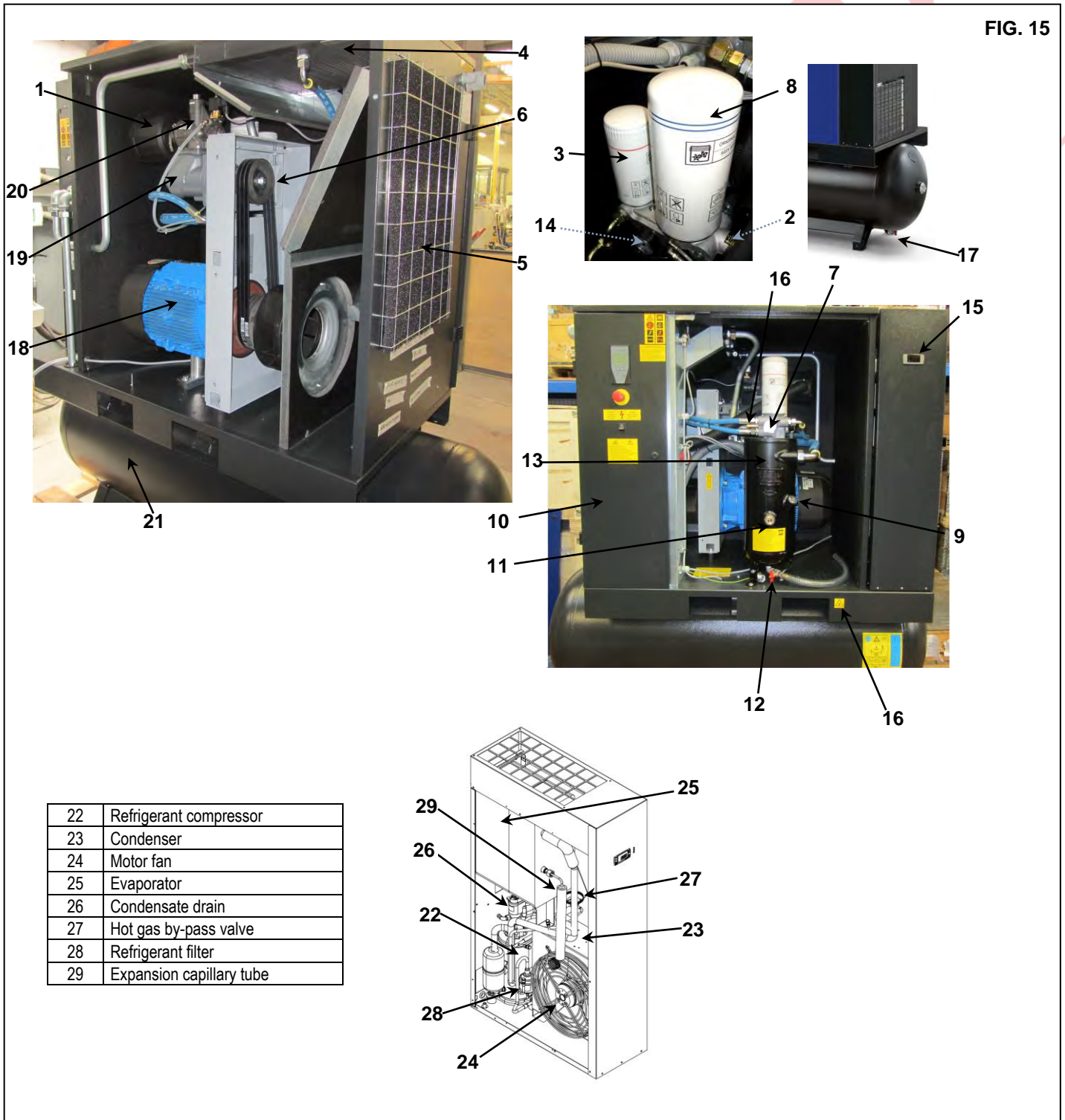

22	Refrigerant compressor
23	Condenser
24	Motor fan
25	Evaporator
26	Condensate drain
27	Hot gas by-pass valve
28	Refrigerant filter
29	Expansion capillary tube

## 14.2 COMMAND AND CONTROLLERS



BEFORE CARRYING OUT THE OPERATION TEST, READ CAREFULLY AND ACQUIRE A GOOD KNOWLEDGE OF THE COMMAND FUNCTIONS.

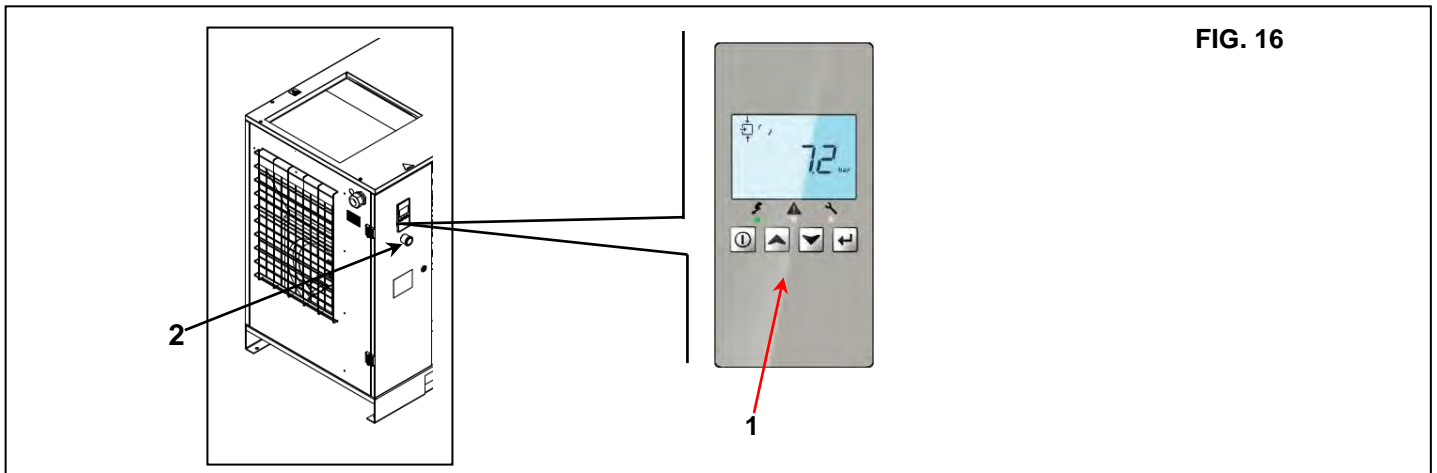

FIG. 16

- |                                                                    |  |
|--------------------------------------------------------------------|--|
| 1) Controller                                                      |  |
| 2) Emergency stop button with mechanical seal and rotation release |  |

## 14.3 COMPRESSOR CONTROLLER



FIG. 17

### 14.3.1 INTRODUCTION

In general, the controller has following functions:

- Controlling the compressor;
- Protecting the compressor;
- Monitoring service intervals;
- Automatic restart after voltage failure (made inactive);

### AUTOMATIC CONTROL OF THE COMPRESSOR

The controller maintains the net pressure between programmable limits by automatically loading and unloading the compressor. A number of programmable settings, e.g. the unloading and loading pressures, the minimum stop time and the maximum number of motor starts are taken into account.

The controller stops the compressor whenever possible to reduce the power consumption and restarts it automatically when the net pressure decreases. If the expected unloading period is too short, the compressor is kept running to prevent too short standstill periods.

### PROTECTING THE COMPRESSOR

#### SHUTDOWN WARNING

The shutdown warning is a programmable warning that advises the operator about a possible problem before the shutdown. If one of the measurements exceeds the programmed shutdown warning level, this will also be indicated to warn the operator before the shutdown level is reached.

## SHUTDOWN

If the compressor element outlet temperature exceeds the programmed shutdown level or the overload relay of the main motor trips, the compressor will be stopped. This will be indicated on the display of the controller.

## SERVICE WARNING

If the service timer exceeds the preset value, the controller advises the operator via the display, to carry out the service maintenance.

## AUTOMATIC RESTART AFTER VOLTAGE FAILURE

The controller has a built-in function to automatically restart the compressor when the voltage is restored after voltage failure. This function is deactivated on compressors leaving the factory.

## REMOTE CONTROL

### DESCRIPTION

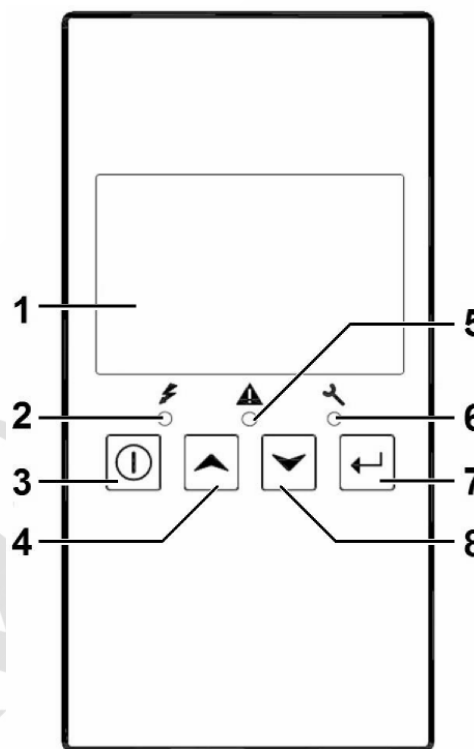

FIG. 17/A









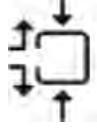

Controller

### 14.3.2 DETAILED DESCRIPTION

Reference	Designation	Function
1	Display	Shows icons and operating conditions.
2	LED, Voltage on	Indicates that the voltage is switched on.
3	Start/stop button	Keep pressed for 3 seconds to start compressor. Press to stop compressor if running. Use this button to go to previous screen or to end the current action.
4	Scroll button	Use these buttons to scroll through the menu.
5	LED, Warning	Is lit if a warning condition exists.
6	LED, Service	Is lit when service is needed.
7	Enter button	Press 3 seconds to enter in menu. Use this button to confirm the last action. Press 5 seconds to reset alarm.
8	Scroll button	Use these buttons to scroll through the menu.



### 14.3.3 ICONS USED ON THE DISPLAY

FUNCTION	ICON	DESCRIPTION
Stopped/Running		When the compressor is stopped, the icon stands still. When the compressor is running, the icon is rotating.
Compressor status		Motor stopped
		Running unloaded Running unloaded (blinking for manual stop)
		Running loaded
Machine control mode		Remote start/stop active
Automatic restart after voltage failure		Automatic restart after voltage failure is active
Active protection functions		Emergency stop
Service		Service required
Units	<b>MPa</b>	Pressure unit (Mega Pascal)
	<b>bar</b>	Pressure unit (pounds per square inch)
	<b>PSI</b>	Pressure unit (bar)
	<b>°C</b>	Temperature unit (degree Centigrade)
	<b>°F</b>	Temperature unit (degree Fahrenheit)
		Motor
		A time/delay parameter is displayed. NOTE: <ul style="list-style-type: none"> <li>• x1000: ON if the displayed value is in thousands of</li> <li>• hrs: ON if the displayed value is in hours</li> <li>• s: ON if the displayed value is in sec</li> </ul>
		Element outlet temperature

#### 14.3.4 MAIN SCREEN

At power on, the first screen is a test screen (Icon, digit and led are on). The next screen is the Main screen, shown automatically. The Main screen shows:

- The compressor status by means of pictographs;
- The air outlet pressure;



84702D

**Main screen with pressure (stopped compressor)**

From the Main screen, it is possible with up and down buttons (4-8) to change the view from pressure to temperature of the element outlet.



84703D

**Main screen with temperature (stopped compressor)**

#### 14.3.5 MAIN FUNCTION

To switch on the compressor, press start/stop button (3) for 3 seconds. The compressor starts and the status is shown:

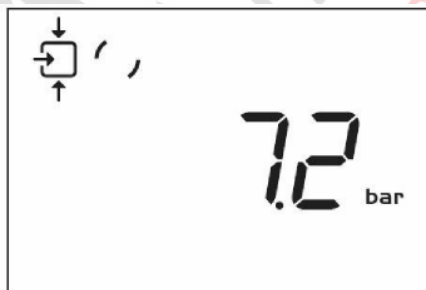

84704D

**Screen with running compressor**

To stop the compressor, push start/stop button (3). The compressor unloads:



84705D

**Screen with unloading compressor**

When the unload time is elapsed, the compressor is stopped and the controller goes back to main screen:



84706D

**Main screen with pressure (stopped compressor)**

To enter the main menu (starting from the Main screen), press the enter button (7) for 3 seconds. The main menu is shown:



84707D

**First screen of main menu**

It is possible to scroll in the menu with the up or down buttons (4-8). To select one item push the enter button (7). To end the current action push start/stop (3) button.

If the emergency stop button is pushed, the compressor stops immediately and the following screen will appear:



84708D

**Emergency stop**

When the emergency push button is restored, reset the alarm by pressing the enter button (7) for 5 seconds. The following screen will appear:

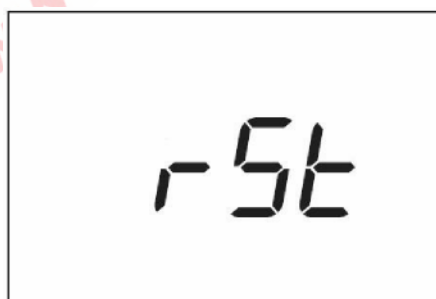

84709D

**Alarm reset**



### 14.3.6 SHUTDOWN WARNING

#### DESCRIPTION

A shutdown warning will appear in the event of:

- A too high temperature at the outlet of the compressor element. **Compressor element outlet temperature**
- If the outlet temperature of the compressor element exceeds the shutdown warning level (factory set at 110°C/ 230°F), warning LED (5) is on.
- Press Scroll up or down buttons (4-8). The screen shows the temperature at the compressor element outlet.

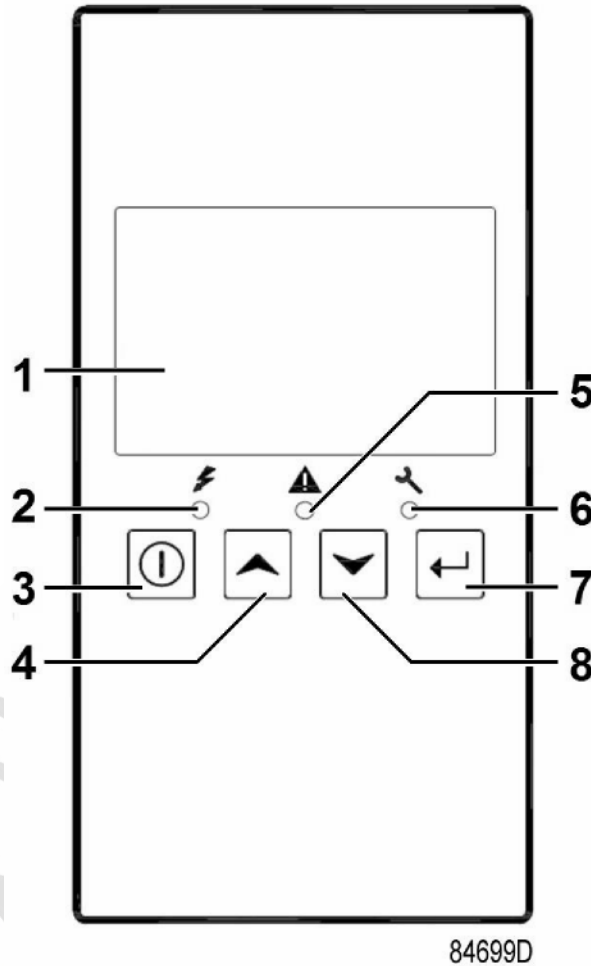

It remains possible to check the actual status of other parameters by pressing the enter button (7) for 3 seconds. Press button (3) to stop the compressor and wait until the compressor has stopped. The warning message will disappear as soon as the warning condition disappears.

### 14.3.7 SHUTDOWN

#### DESCRIPTION

THE COMPRESSOR WILL SHUT-DOWN:

- In case the temperature at the outlet of the compressor element exceeds the shutdown level (detected by temperature sensor (TT11) or by temperature switch (TSHH11/TSHH21).
- In case the pressure at the outlet of compressor exceeds the shutdown level (PT20)
- In case of error of the outlet pressure sensor (PT20) or temperature sensor (TT11).
- In case of overload of the compressor motor (M1)

## COMPRESSOR ELEMENT OUTLET TEMPERATURE

If the outlet temperature of the compressor element exceeds the shutdown level (factory setting 115°C/ 239°F):

- The compressor will shutdown.
- Alarm LED (5) will flash.
- The following screen will appear:

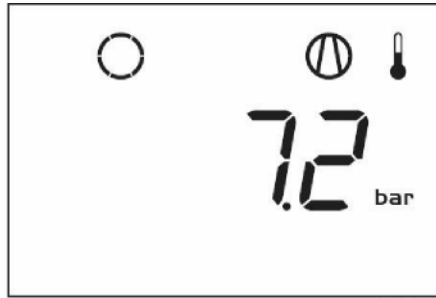

84711D

Main screen with shutdown indication, element outlet temperature

- The related pictograph  will appear flashing.
- Scroll Up or Down buttons (4-8) until the current element outlet temperature appears.



84712D

Shutdown screen, element outlet temperature

The screen shows that the temperature at the outlet of the compressor element is 117 °C.

- When the shutdown condition has been solved, press the Enter button (7) for 5 seconds.
- When <rSt> appears on the display, the compressor can be restarted.

## COMPRESSOR OUTLET PRESSURE



84711D

If the outlet pressure of the compressor element exceeds the shutdown level :

- The compressor will shutdown.
- Pressure readout will flash

## MOTOR OVERLOAD OR PHASE SEQUENCE INCORRECT

In the event of motor overload or incorrect supply phase connection:

- The compressor will shut down or the compressor can't start
- Alarm LED (5) will flash.
- The following screen will appear:



84713D

Main screen with shutdown indication, motor overload



84713D

Main screen with shutdown indication, phase sequence incorrect

- Contact your dealer for fault troubleshooting or switch off main supply and exchange 2 supply phases
- When the shutdown condition has been solved, press the enter button (7) for 5 seconds.
- When <rSt> appears on the display, the compressor can be restarted

## ERROR PRESSURE/TEMPERATURE SENSOR

In the event of an error of the outlet pressure sensor (PT20) or temperature sensor (TT 11):

- The compressor will shutdown.
- The following screen will appear:

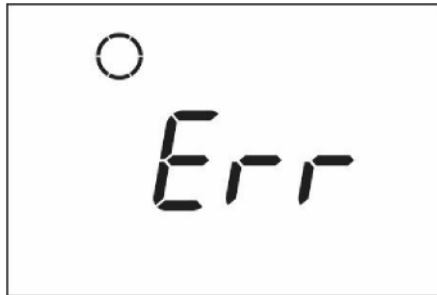

84714D

Example of error sensor

## 14.3.8 SERVICE WARNING

### DESCRIPTION

A service warning will appear when the service timer has reached the preset time interval. If the service timer exceeds the programmed time interval, alarm LED (6) is blinking with a following screen:

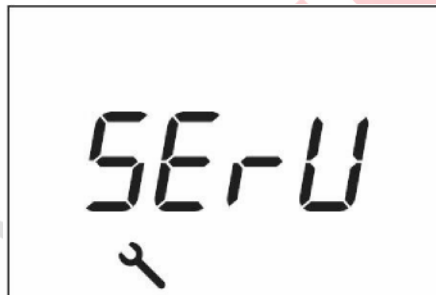

84715D

Blinking screen

- Press Enter button (7) to enter the main menu.
- Select <dAtA> and press Enter button (7) to enter the data menu.
- Scroll (buttons 4-8) until <d.6> appear, the service symbol is shown.
- Press enter button (7).
- The actual reading of the service timer is shown in <hrs>.

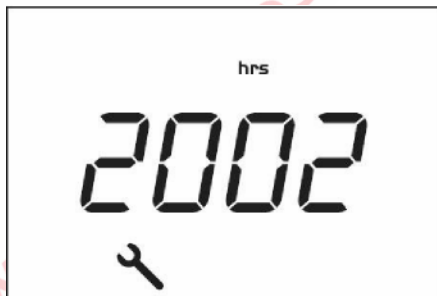

84716D

Example of running hours screen

The example screen shows that the service timer is at 2002 hours.

Stop the compressor, switch off the voltage and carry out the required service actions. After servicing, reset the service timer.

See section [Calling up/resetting the service timer](#).



### 14.3.9 SCROLLING THROUGH ALL SCREENS

#### COMPRESSOR CONTROLLER MENU TREE

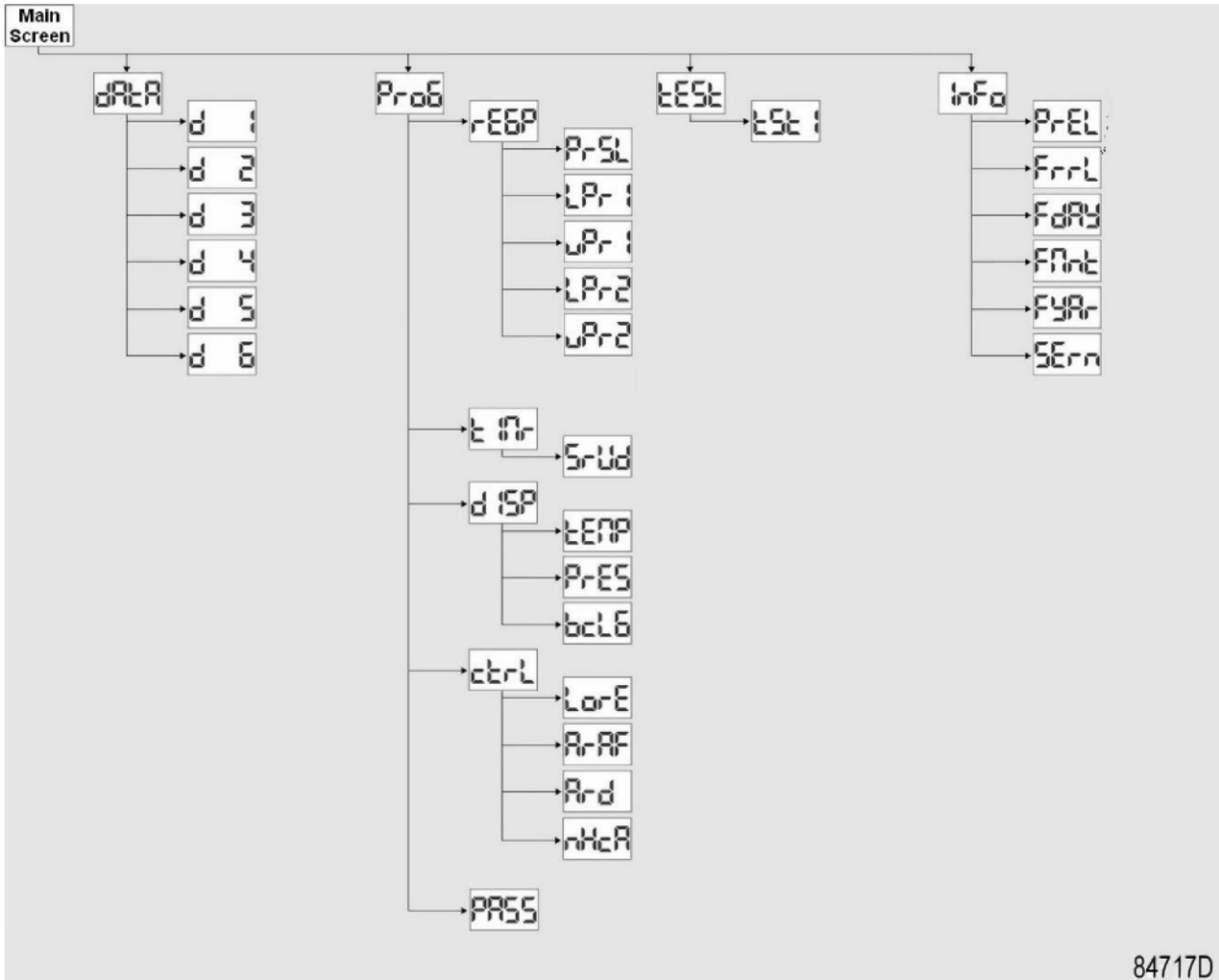

84717D

#### General overview of the menu

From the Main screen press the enter button (7) for 3 seconds to enter the Menu. You will find the following items:

- **Data menu:** Data counters parameters.
- **Programming menu:** Submenu of Regulation pressure, Timer, Display setting and Control setting.
- **Test menu:** Display test.
- **Info menu:** Information of firmware release.

OVERVIEW OF THE SCREENS

Menu item	Submenu	Digital input screen	Designation
<dAtA> Data		<d.1>	Calling up running hours
		<d.2>	Calling up motor starts
		<d.3>	Calling up module hours
		<d.4>	Calling up loading hours
		<d.5>	Calling up load solenoid valve
		<d.6>	Calling up service timer
<ProG> Programming	<rEG.P> Regulation Pressure	<Pr.SL>	Calling up modifying pressure band selection
		<LPr.1>	Calling up modifying pressure band settings
		<uPr.1>	Calling up modifying pressure band settings
		<LPr.2>	Calling up modifying pressure band settings
		<uPr.2>	Calling up modifying pressure band settings
	<tiMr> Timer	<SrV.d>	Calling up maintenance warning
	<diSP> Display	<EMP>	Calling up modifying unit of temperature
		<PrES>	Calling up modifying unit of pressure
		<bC.LG>	Calling up modifying time of backlight
	<Ctrl> Control	<Lo.rE>	Local/remote start/stop
		<Ar.Af>	Calling up automatic restart after voltage failure
		<Ar.d>	Delay automatic restart after voltage failure
		<nHCA>	Number of hourly compressor activation
	<PASS>		Activating password protection
<tEst> Test		<tSt. 1>	Display testing
<info> Info		<P.rEL>	Parameter Map Release
		<F.rRI>	Firmware Release
		<F.dAY>	Firmware Release Day
		<F.Mnt>	Firmware Release Month
		<F.YAr>	Firmware Release Year
		<SEr.n>	Serial number

### 14.3.10 CALLING UP RUNNING HOURS

Starting from the Main screen:

- Press Enter button (7) for 3 seconds to enter the Main menu.
- Select <dAtA> and press Enter button (7) to enter the Data menu.
- Scroll Up or Down buttons (4-8) until <d.1> and the motor stopped symbol is shown.
- Press Enter button (7): the running hours are shown.

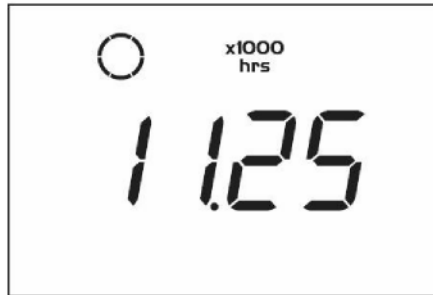

The screen shows the unit used <x1 000 hrs> and the value <11.25>: the running hours of the compressor are 11250 hours.

### 14.3.11 CALLING UP MOTOR STARTS

Starting from the Main screen:

- Press Enter button (7) for 3 seconds to enter the Main menu.
- Select <dAtA> and press Enter button (7) to enter the Data menu.
- Scroll Up or Down buttons (4-8) until <d.2> and the motor symbol is shown.
- Press Enter button (7): the number of motor starts is shown.

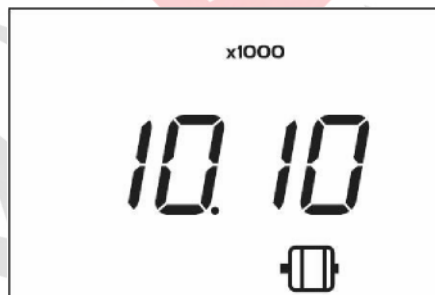

This screen shows the number of motor starts (x1 or - if <x1000> lights up - x1 000). In the above example, the number of motor starts is 10100.

### 14.3.12 CALLING UP MODULE HOURS

Starting from the Main screen:

- Press Enter button (7) for 3 seconds to enter the Main menu.
- Select <dAtA> and press Enter button (7) to enter the Data menu.
- Scroll Up or Down buttons (4-8) until <d.3> and <hrs> is shown.
- Press Enter button (7): the module time appears.



In the example shown, the screen shows the unit used <hrs> and the value <5000>: the controller module has been in service during 5000 hours.

### 14.3.13 CALLING UP LOADING HOURS

Starting from the Main screen:

- Press Enter button (7) for 3 seconds to enter the Main menu.
- Select <dAtA> and press Enter button (7) to enter the Data menu.
- Scroll Up or Down buttons (4-8) until <d.4> and the running loaded symbol is shown.
- Press Enter button (7): the loading time is shown.



84721D

The screen shows the unit used <hrs> (or <x1000 hrs>) and the value <1755>: the compressor has been running loaded during 1755 hours.

### 14.3.14 CALLING UP LOAD SOLENOID VALVE

Starting from the Main screen:

- Press Enter button (7) for 3 seconds to enter the Main menu.
- Select <dAtA> and press Enter button (7) to enter the Data menu.
- Scroll Up or Down buttons (4-8) until <d.5> and the running loaded symbol is shown.
- Press Enter button (7): the number of loadings is shown.

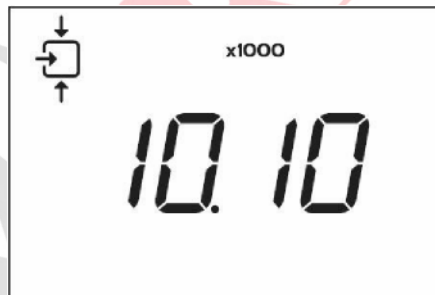

84722D

This screen shows the number of loading actions (x1 or - if <x1 000> lights up - x1 000). In the above example, the number of unload to load actions is 10100.



#### 14.3.15 CALLING UP/RESETTING THE SERVICE TIMER

Starting from the Main screen:

- Press Enter button (7) for 3 seconds to enter the Main menu.
- Select <dAtA> and press Enter button (7) to enter the Data menu.
- Scroll Up or Down buttons (4-8) until <d.6> and <hrs> is shown.

Press Enter button (7): the loading time is shown.



This screen shows the unit used <hrs> (or <x1 000 hrs>) and the value <1191>. In the example shown, the compressor has run 1191 hours since the previous service.

To reset the timer, contact your supplier.

#### 14.3.16 CALLING UP/MODIFYING PRESSURE BAND SELECTION

Starting from the Main screen:

- Press Enter button (7) for 3 seconds to enter the Main menu.
- Select <ProG> and press Enter button (7) to enter the Programming menu.
- Scroll Up or Down buttons (4-8) to <reG.P> for regulation pressure.
- Press Enter button (7) to enter the submenu.

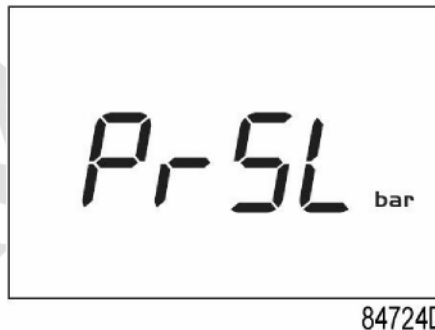

- Scroll Up or Down buttons (4-8) until <PrSL> is shown and then press Enter button (7).
- Pressure band 1 (<SEL. 1>) is shown. Scroll Up or Down buttons (4-8) to pressure band 2 (<SEL.2>).
- Press Enter button (7) on the desired pressure band.

### 14.3.17 CALLING UP/MODIFYING PRESSURE BAND SETTINGS

Starting from the Main screen:

- Press Enter button (7) for 3 seconds to enter the Main menu.
- Select <ProG> and press Enter button (7) to enter the Programming menu.
- Scroll Up or Down buttons (4-8) to <reG.P> for regulation pressure.
- Press Enter button (7) to enter the submenu.

<LPr. 1> is parameter of Load Pressure band 1 <uPr. 1> is parameter of Unload Pressure band 1 <LPr.2> is parameter of Load Pressure band 2 <uPr.2> is parameter of Unload Pressure band 2

- Scroll Up or Down buttons (4-8) and press Enter button (7) to select parameter.
- The actually used pressure is shown. Scroll Up or Down buttons (4-8) to set pressure value and press Enter button (7) to confirm. The unit blinks and the new setting is saved.

### 14.3.18 CALLING UP/MODIFYING THE UNIT OF TEMPERATURE

The unit of temperature measurement can only be changed when the compressor is stopped. Starting from the Main screen:

- Press Enter button (7) for 3 seconds to enter the Main menu.
- Select <ProG> and press Enter button (7) to enter the Programming menu.
- Scroll Up or Down buttons (4-8) to <diSp> for display settings.
- Press Enter button (7) to enter the submenu.
- Scroll Up or Down buttons (4-8) to <tEMP> and press Enter button (7).
- The actually used unit is shown. Possible settings are <'C > and <'F >.
- Scroll Up or Down buttons (4-8) to set the unit of temperature and press Enter button (7) to confirm. The unit blinks and is saved.

### 14.3.19 CALLING UP/MODIFYING THE UNIT OF PRESSURE

The unit of pressure measurement can only be changed when the compressor is stopped. Starting from the Main screen:

- Press Enter button (7) for 3 seconds to enter the Main menu.
- Select <ProG> and press Enter button (7) to enter the Programming menu.
- Scroll Up or Down buttons (4-8) to <diSp> for display settings.
- Press Enter button (7) to enter the submenu.
- Scroll Up or Down buttons (4-8) to <PrES> and press Enter button (7).
- The actually used unit is shown. Possible settings are <bar>, <psi> and <MPa>.
- Scroll Up or Down buttons (4-8) to set the unit of pressure and press Enter button (7) to confirm. The unit blinks and is saved.

### 14.3.20 CALLING UP/MODIFYING BACKLIGHT TIME

The backlight will be activated after pressing any button and for the interval of time set in the parameter <bC.LG> (in sec).

Starting from the Main screen:

- Press Enter button (7) for 3 seconds to enter the Main menu.
- Select <ProG> and press Enter button (7) to enter the Programming menu.
- Scroll Up or Down buttons (4-8) to <diSp> for display settings.
- Press Enter button (7) to enter the submenu.
- Scroll Up or Down buttons (4-8) to <bC.LG> and press Enter button (7).
- The current backlight setting is shown. It is possible to set a value between 0s and 1 20s.
- Scroll Up or Down buttons (4-8) to set the time of backlight and press Enter button (7) to confirm. The unit blinks and is saved.

### 14.3.21 ACTIVATING AUTOMATIC RESTART AFTER VOLTAGE FAILURE

#### DESCRIPTION

This function allows the compressor to restart automatically after voltage failure. Your dealer can only do the activation. Please contact him for further details.

After any power failure, before restarting, the compressor will wait for a fixed time. When delay time is running, the display will show the related countdown value as below:



Example countdown delay time of automatic restart after power failure.

### 14.3.22 ACTIVATING AUTOMATIC RESTART AFTER VOLTAGE FAILURE

#### DESCRIPTION

### 14.3.23 KEYBOARD LOCK

Keep both Up and Down buttons pressed for more than 3 seconds to lock or unlock the keyboard.

- The display will show the label <Loc> blinking for 3 seconds if the keyboard has been locked.
- The display will show the label <UnLo> blinking for 3 seconds if the keyboard has been unlocked.



Example Lock/unlock screen.

14.4 DRYER CONTROLLER (In case of compressor version with integrated dryer)



**BEFORE CARRYING OUT THE OPERATION TEST, READ CAREFULLY AND ACQUIRE A GOOD KNOWLEDGE OF THE COMMAND FUNCTIONS.**

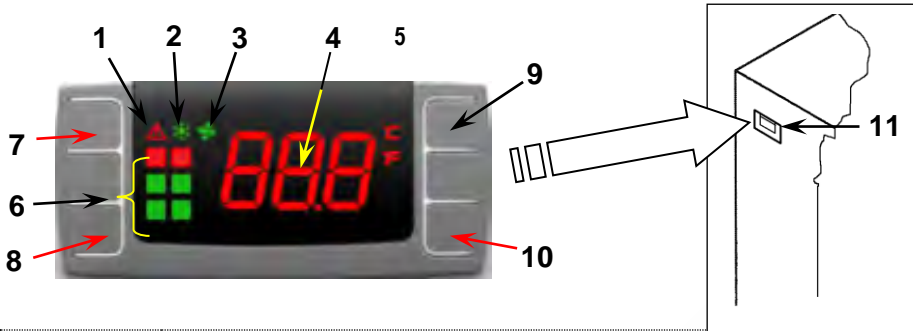

Reference	Name
1	Alarm icon
2	Refrigerant compressor icon
3	Fan icon
4	Dryer ON
5	PDP indicator
6	PDP indicator
7	Button to snooze or to reset the alarm
8	SET button
9	UP button
10	DOWN button
8 + 9	Back to previous screen
8 + 10	Menu
11	Digital controller

ICONS

ICON	NAME	MODE	FUNCTIONS
	Alarm	OFF	No active alarms
		ON	Probe failure alarm
		ON	High/Low temperature alarm
		ON	Service alarm
	Refrigerant compressor	OFF	Dryer off
		ON	Dryer on
		Flashing + SE	Maintenance warning
		Flashing + L2	Dewpoint too low / Dryer is stopped
		Flashing + Countdown	Residual time before start
	Fan	OFF	Fan off
		Flashing	Not applicable
		ON	Fan on
		Flashing + H3	Too high discharge temperature of the refrigerant compressor (see "H3" pag. 12) Dryer is stopped

STARTING DRYERS

	Flashing: countdown before starting the refrigerant compressor for internal pressure balancing (180 seconds).
--	---------------------------------------------------------------------------------------------------------------



## REMOTE ALARM FUNCTION

The controller allows to remotely control a number of alarms. This is managed by means of a free NC (Normally Closed) contact. The contact opens in case of an alarm or when the dryer is switched off. (Contact customer center for more details)

### TROUBLE-SHOOTING AND EMERGENCY REMEDIES

N.B. OPERATIONS MARKED ■ ■ MUST BE CARRIED OUT BY PROFESSIONALLY SKILLED PERSONNEL APPROVED THE MANUFACTURER

Display	Flashing fault message	Description	Possible root causes	Observations
		Dryer is working OK	n/a	n/a
		Dryer is working OK	n/a	n/a
		Warning icon NOT flashing, label P1 flashing	Fan control probe failed	■■ replace probe
		Warning icon NOT flashing, label P2 flashing	PDP Temp probe failed	■■ replace probe
		Warning icon NOT flashing, label P3 flashing	Refrigerant compressor temperature probe failed	■■ replace probe
		Warning icon NOT flashing, label H2 flashing	High PDP	■■ refrigerant leak ■■ flow rate / inlet ■■ temperature exceeding the limit. ■■ call for service
		Warning icon NOT flashing, label L2 flashing	Low PDP	■■ hot gas by pass valve out of order. ■■ ambient temperature lower than limits ■■ call for service
		Warning icon NOT flashing, label H3 flashing	High refrigerant compressor temperature	■■ refrigerant leak ■■ call for service
		Warning icon NOT flashing, label H1 flashing	High temperature discharge condenser	■■ check probe ■■ call for service

### “EE” ALARM

EE alarm is shown when internal EPROM errors happens, if this warning will appear, the dryer will stop running. The error can be reset by pressing one of the four buttons of the controller, anyway please replace the controller itself.



**NOTE: In case of EE alarm please contact your tech support.**

### “SE” ALARM

After 6000Hrs, the controller will issue a “SE” warning. This is the maintenance due warning.



### FREEZE PROTECTION FUNCTION

Once the digital controller detects a dewpoint temperature below 28.4 °F (-2°C) during more than 2 minutes (L2 Alarm), it switches off the refrigerant compressor.

### AUTOMATIC CUT OUT OF REFRIGERANT COMPRESSOR

If the refrigerant temperature detected at the delivery pipe of refrigerant compressor overcome the limit setted by manufacturer, the controller stops the refrigerant compressor in order to avoid further possible failure.

### COMPRESSOR RE-START AFTER A STOP

If freezing or superheating alarm occurs, the controller stops the compressor and the re-start has to be manually activated.

Before re-starting the dryer, it is necessary to identify the root cause; such alarms indicate possible failure it is necessary to call customer center. Restart the dryer without a deep investigation on possible root cause will affect the reliability of the dryer and overrule the warranty reimbursement.

Press button Ref. 7 Fig. 9 to reset the alarm.

The dryer restarts when both the following conditions are satisfied:













- The dew point temperature is higher than 28 °F (-2°C)
- 180 seconds are elapsed from the refrigerant compressor stop (minimum balancing pressure stop time).

A countdown is available if the reset is made before the minimum stop time.









### SILENT ALARM FUNCTION

To snooze the alarm, press button Ref. 7 (See Fig. 9)

HOW TO RESET THE MAINTENANCE WARNING: FOLLOW STEPS 1 TO 12

<p>1</p>  <p>PDP is flashing between standard view and "SE" alarm</p>	<p>2</p>  <p>Push and hold buttons "SET" and "DOWN" to enter in the menu.</p>	<p>3</p>  <p>Message "SE" appears on display.</p>
<p>4</p>  <p>Push and release button "UP".</p>	<p>5</p>  <p>Message "rS" appears on display.</p>	<p>6</p>  <p>Push and release button "SET".</p>
<p>7</p>  <p>Message "n" appears on display.</p>	<p>8</p>  <p>Push and release button "UP".</p>	<p>9</p>  <p>Message "y" appears on display.</p>
<p>10</p>  <p>Push and release "SET" to reset service alarm.</p>	<p>11</p>  <p>Message "y" blinks for 3 seconds.</p>	<p>12</p>  <p>Then "rL" is fixed and "°C" blinks on display for ~10 seconds. Service alarm is reset</p>

## PROCEDURE TO SET THE SERVICE INTERVAL ON PDP DEVICE

<p>1</p>  <p>PDP is showing standard view.</p>	<p>2</p>  <p>Push and hold buttons "SET" and "DOWN" to enter in the menu.</p>	<p>3</p>  <p>Message "SE" appears on display.</p>
<p>4</p>  <p>Push and release "SET" to enter in the "SE" menu.</p>	<p>5</p>  <p>Current service interval is displayed. ("60" or different value from "0" to "99")</p>	<p>6</p>  <p>Select desired service interval using "UP" or "DOWN". (40=4000h, 55=5500h, 80=8000h,...)</p>
<p>7</p>  <p>Push and release "SET" to configure new service interval.</p>	<p>8</p>  <p>Value selected blinks for 3 seconds.</p>	<p>9</p>  <p>Then "rS" is fixed and "C" blinks on display for ~10 seconds. New service interval is set</p>



## 15.0 ORDINARY MAINTENANCE TO BE DONE BY THE USER



**BEFORE CARRYING OUT ANY MAINTENANCE, IT IS OBLIGATORY TO STOP THE MACHINE AND DISCONNECT IT FROM THE POWER MAINS AND FROM THE COMPRESSED AIR DISTRIBUTION NETWORK.**

The user may carry out the maintenance jobs described in this chapter.

The more complex maintenance jobs, which require professionally skilled personnel, are listed in the chapter on **GENERAL ROUTINE MAINTENANCE**. (See Chap. 21.0)

### 15.1 GENERAL INFORMATION

### 15.2 MAINTENANCE PROGRAMME

■ OPERATIONS THAT MAY BE CARRIED OUT BY THE USER

■ ■ OPERATIONS THAT REQUIRE SKILLED PERSONNEL; THESE OPERATIONS ARE ILLUSTRATED IN PART B OF THIS MANUAL.

These maintenance intervals are recommended for work environments that are not dusty and are well ventilated. For particularly dusty environments, double the frequency of controls.

Every Day (after use)	■ ■	Drain condensate from the air tank Check automatic condensation emptying
Every 50 working hours	■	Drain condensate from the oil collector
	■	Check the oil level
	■	Clean the filtering panel
Every 500 hours	■	Clean the air suction filter
	■	Clean the condenser battery (on the dryer if fitted)
	■	Clean the dirt collection filter
	■	Fixing electrical cables (at first 500 hrs)
Every 2000 hours (or at least every year)		
	■ ■	Change the oil filter
	■	Change the suction filter
	■	Change the filter mesh of dryer condensate drain
	■ ■	Retighten all power cable connections
	■ ■	Safety temperature test
Every 4000 hours (or at least every 2 years)	■ ■	Clean the finned surface of the air-oil cooler
	■ ■	Change the oil separating filter
	■ ■	Service kit for dryer condensate drain
	■	Change the filter panel
	■ ■	Replace the belts
	■	Replace the line afterfilter (change the filter cartridge at least once a year)
Every 8000 hours (or at least every 3 years)	■ ■	Service kit for non-return valve
	■ ■	Service kit for dryer condensate drain
	■ ■	Service kit for minimum pressure valve and thermostatic valve
	■ ■	Kit revision intake valve
	■ ■	Checking the status of the oil return valve and oil pipes
	■ ■	Change the oil
Every 24000 hours	■ ■	Kit revision of the compressor unit
	■ ■	Service kit Motor (bearings)

**COMPRESSED**  
AIR ADVISORS  
Inc.

**Compressed Air Advisors, Inc.**

Phone: 877.247.2381

info@compressedairadvisors.com

www.compressedairadvisors.com

### 15.3 DRAINING CONDENSATE FROM THE OIL TANK

If the compressor work cycle contemplates long pauses during which the machine cools down, a certain amount of condensate will gather in the oil tank. This happens, for example, when stopping overnight or at weekends. The condensate must be drained off every 50 hours or every week. This operation may be performed only when the machine is cold, that is when it has been switched off for at least 8 hours.

**! BEFORE DRAINING THE CONDENSATE, IT IS OBLIGATORY TO STOP THE MACHINE AND DISCONNECT IT FROM THE POWER MAINS.**

Proceed as follows:

- Switch off the machine with pushbutton Ref. 1 Fig. 18: In this way, the machine stops after 30 seconds of idle running.
- Disconnect the power supply by means of the disconnecter switch, Ref. 3 Fig. 18 (compressor) and Ref. 3A Fig. 18 (on the dryer if fitted).

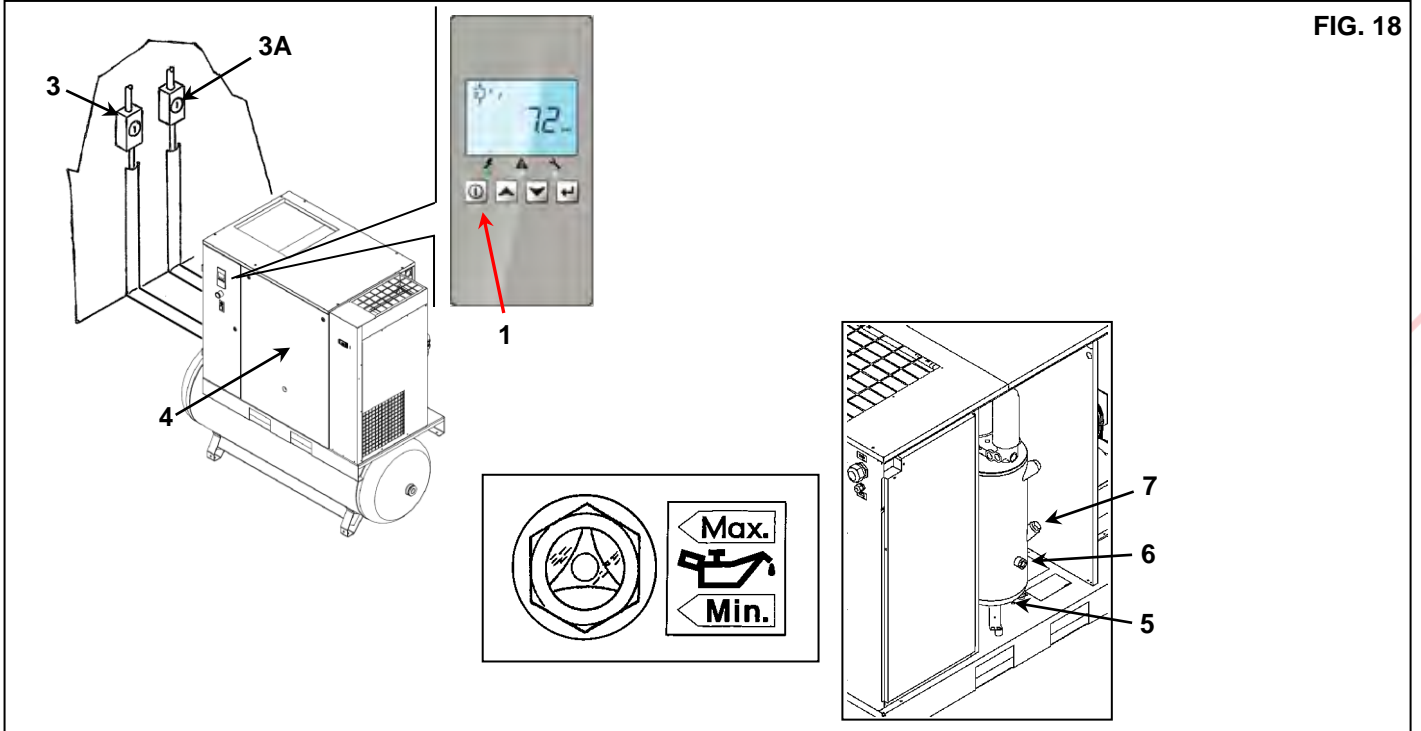

- Wait for the machine to cool down.
- Remove the panels Ref. 4 Fig. 18 with the key provided.
- SLOWLY turn on the tap Ref. 5 Fig. 18 and let the condensate flow out.
- When the first traces of oil appear, turn off the tap.

**! CONDENSATE MUST BE DISPOSED OF IN CONFORMITY WITH THE LOCAL REGULATIONS IN FORCE.**

- Check the oil level on the indicator Ref. 6 Fig. 18.
- If the oil level is under the minimum, top up as described at point 15.4.

### 15.4 CHECK OIL LEVEL AND TOP UP

- Switch off the machine with push button Ref. 1 Fig. 18: in this way the machine stops after 30 seconds of idle running.
- Disconnect the power supply by means of the disconnecter switch, Ref. 3 Fig. 18 (compressor) and Ref. 3A Fig. 18 (on the dryer if fitted).
- Wait about 5 minutes or at least for the foam in the oil collector to abate.
- Check the oil level on the indicator Ref. 6 Fig. 18
- If the oil level is under the minimum, top up.

**! USE OIL OF THE SAME TYPE AS THAT ALREADY IN THE MACHINE; DO NOT MIX DIFFERENT TYPES OF OIL.**

**! BEFORE CARRYING OUT ANY OPERATION ON THE MACHINE, ENSURE THAT THE ELECTRIC POWER SUPPLY HAS BEEN DISCONNECTED.**

- Open the front panel Ref. 4 Fig. 18 with the special key.
- Slowly open the oil plug Ref. 7 Fig. 18.
- Top up to maximum level Ref. 6 Fig. 18, with oil of the same type in the compressor.
- Turn off the cap of the oil tank Ref. 7 Fig. 18.
- Close the panel Ref. 4 Fig. 18.

**CHECK OIL LEVEL ONLY AFTER UNIT HAS RUN FOR AT LEAST 5 MINUTE.  
DO NOT WAIT TOO LONG AFTER UNIT IS STOPPED AND FOAM IS DISAPPEARED : OIL MAY MIGRATE**

### 15.5 CLEANING THE FILTRATION PANEL

- Switch off the machine with pushbutton Ref. 1 Fig. 18: In this way, the machine stops after 30 seconds of idle running.
- Disconnect the power supply by means of the disconnecter switch, Ref. 3 Fig. 18 (compressor) and Ref. 3A Fig. 18 (on the dryer if fitted).
- Remove the filter panel Ref. 1 - Fig. 19.
- Clean the filtering panel with a jet of air or wash it with water. **Do not use solvents.**
- Once the operation has been completed, reassemble the filtering panel Ref. 1 - Fig. 19.

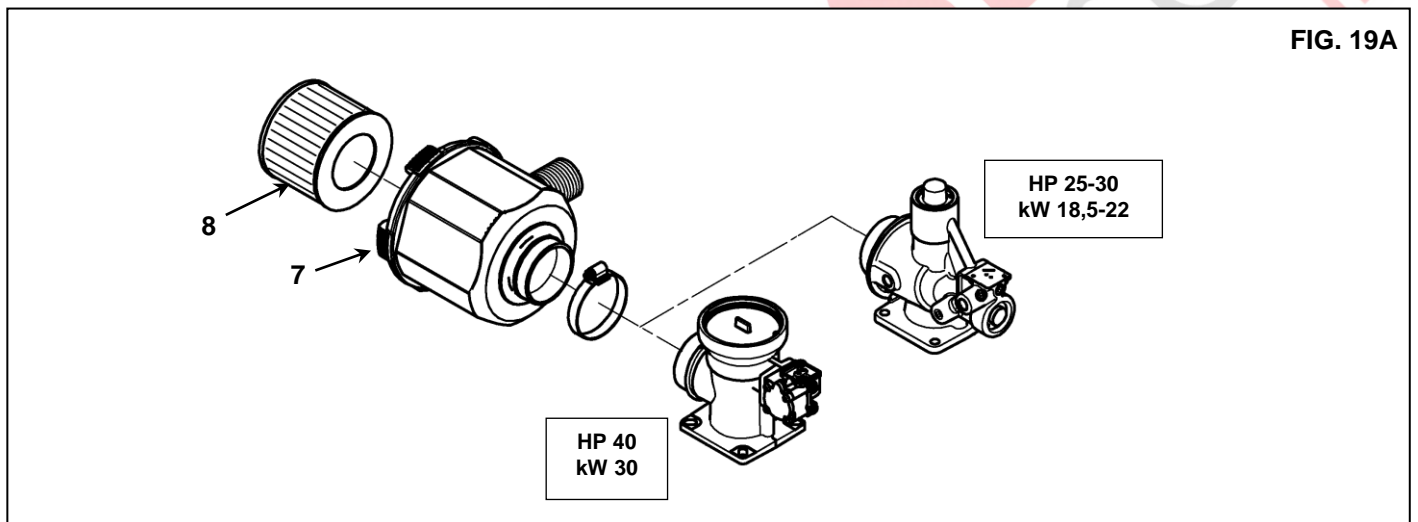
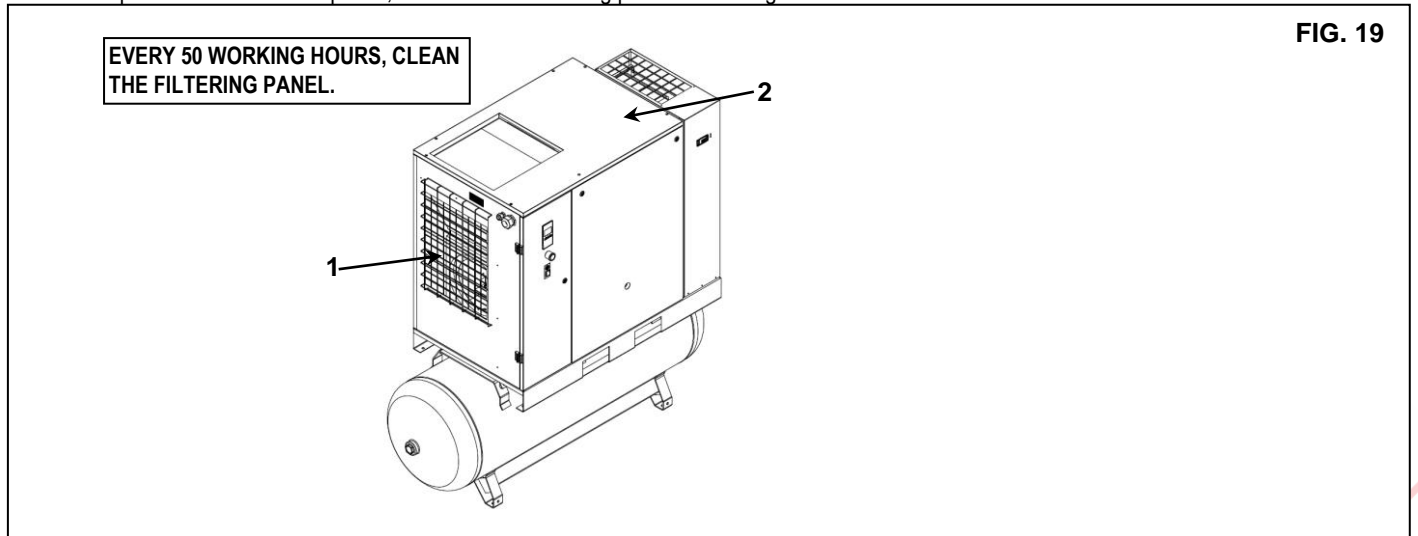

### 15.6 CLEANING THE SUCTION FILTER OR CHANGING THE FILTER

- Switch off the machine with pushbutton Ref. 1 Fig. 18: In this way, the machine stops after 30 seconds of idle running.
- Disconnect the power supply by means of the disconnecter switch, Ref. 3 Fig. 18 (compressor) and Ref. 3A Fig. 18 (on the dryer if fitted).



#### HOT PARTS INSIDE

- Remove the fixed protection device (machine cover) Ref. 2 Fig. 19.
- Remove the cover Ref. 7 Fig. 19A.
- Remove the filter Ref. 8 Fig. 19A.



#### AVOID DROPPING FOREIGN BODIES INTO THE SUCTION MANIFOLD.

- Clean the filter with a jet of air, working from inside to outside, **DO NOT USE WATER OR SOLVENTS.** Alternatively, fit a new filter.
- Clean the disk on which the filter rests with a clean cloth.
- Fit the filter and the cover.
- If necessary, dispose of the old filter in conformity with the local regulations in force.
- Close the fixed protection (machine cover) Ref. 2 Fig. 19 device again, using the appropriate safety screws.

### 15.7 CHECKING THE AUTOMATIC AND MANUAL CONDENSATION EMPTYING (FOR DRYER AND TANK)

**BEFORE CARRYING OUT ANY MAINTENANCE, IT IS OBLIGATORY TO STOP THE MACHINE AND DISCONNECT IT FROM THE POWER MAINS AND FROM THE COMPRESSED AIR DISTRIBUTION NETWORK.**

The automatic and manual condensation drain must be checked (Rif. 1 every 500 hours and Ref. 2 every 24 working hours) Fig. 20. Proceed as follows:

- Press the "TEST" button, Ref. 1 Fig. 20, for a few seconds to check if the condensation is correctly emptied from the drainage pipe
- Check manual condensation emptying from the tank, to ensure that condensation is correctly emptied from the valve, Ref. 2 Fig. 20 (**PURGE EVERY DAY**).

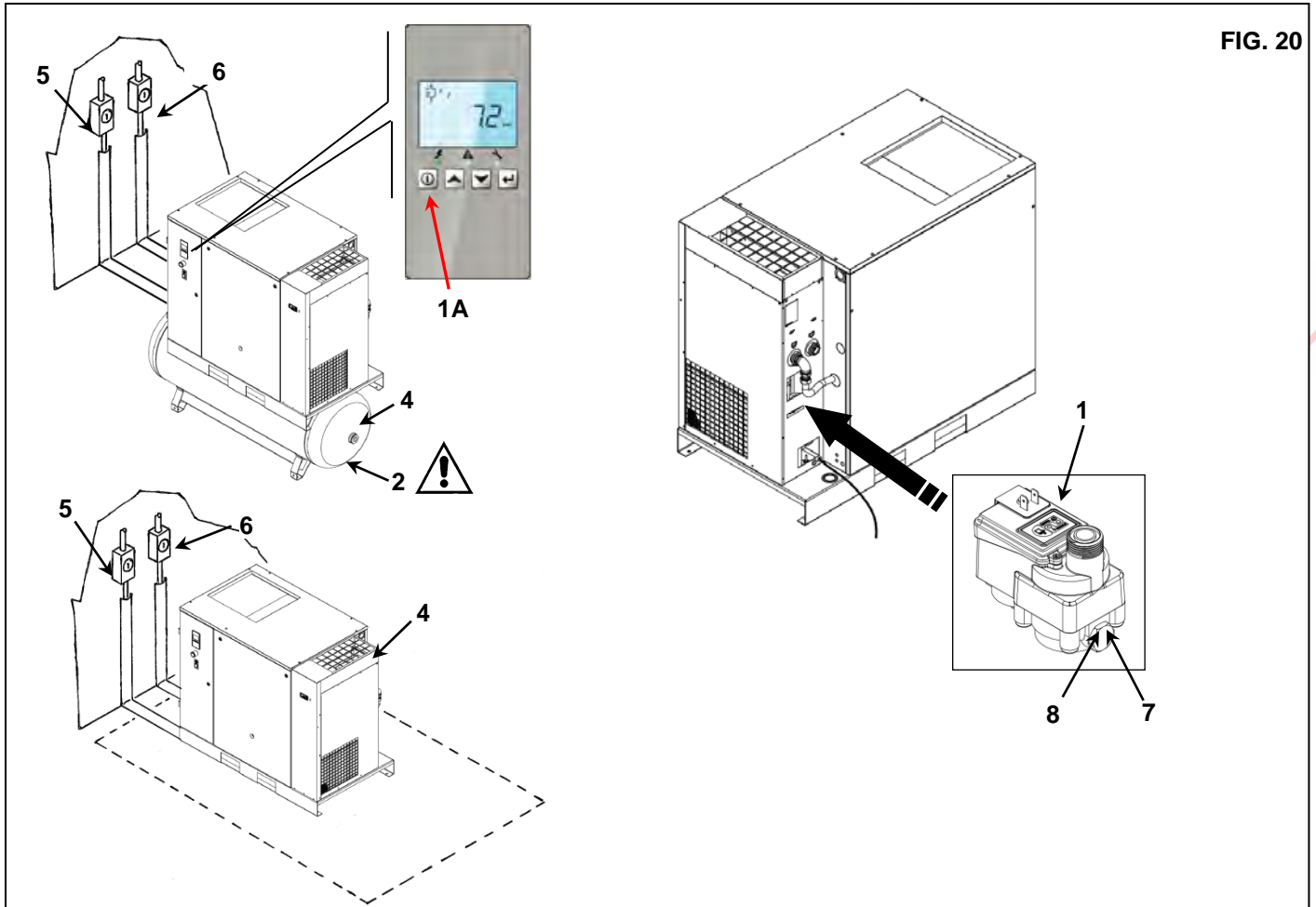

### 15.8 CLEAN THE DIRT COLLECTOR FILTER FOR DRYER (ON THE DRYER IF FITTED)

Proceed as follows:

- Close the tap Ref. 4 Ref. 20
- Depressurise the dryer by pressing the "TEST" condensation emptying button (for about 10-20 seconds) Ref. 1 Fig.20
- Switch off the machine with pushbutton Ref. 1A Fig. 20: In this way, the machine stops after 30 seconds of idle running.
- Disconnect the power supply by means of the disconnector switch, Ref. 5 Fig. 20 (compressor) and Ref. 6 Fig. 20 (on the dryer if fitted).
- Release pressure from the machine by turning on the tap Ref. 2 Fig. 20.
- Remove the stopper Ref. 7 Fig. 20
- Remove the filter Ref. 8 Fig. 20
- Clean the filter with a jet of air, working from inside to outside
- Install the filter, fix the plug.

### 15.9 CLEANING THE CONDENSER BATTERY (ON THE DRYER IF FITTED)



**BEFORE CARRYING OUT ANY MAINTENANCE, IT IS OBLIGATORY TO STOP THE MACHINE AND DISCONNECT IT FROM THE POWER MAINS AND FROM THE COMPRESSED AIR DISTRIBUTION NETWORK.**

The condenser must be cleaned every month.

Proceed as follows:

- Switch off the machine with pushbutton Ref. 1 Fig. 21: In this way, the machine stops after 30 seconds of idle running.
- Disconnect the power supply by means of the disconnecter switch, Ref. 3 Fig. 21 (compressor) and Ref. 2 Fig. 21 (on the dryer if fitted).



**HOT PARTS INSIDE THE DRYER**

- Clean the condenser fins with compressed air (See Fig A). **DO NOT USE WATER OR SOLVENTS.**

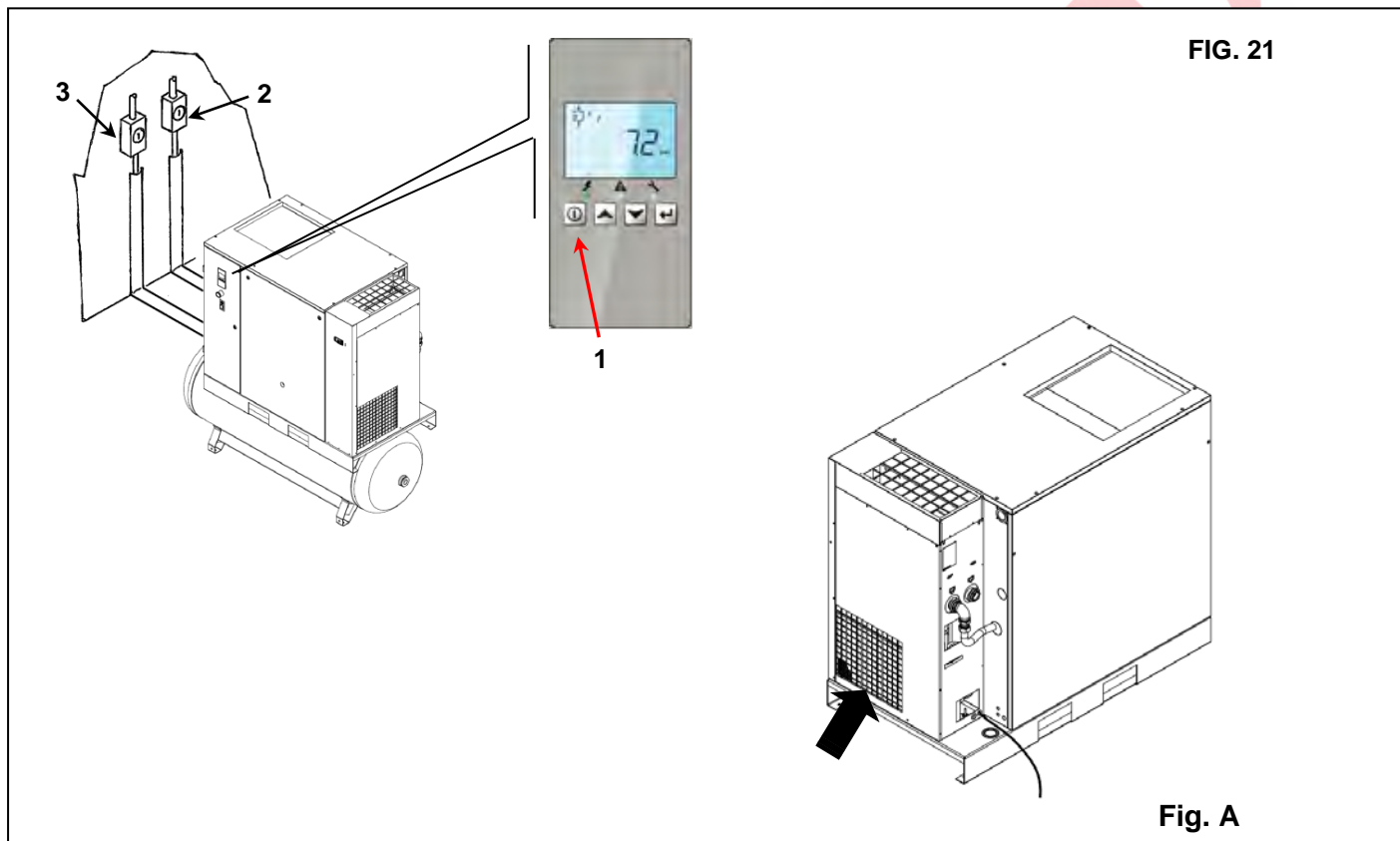



## 16.0 PERIOD OF INACTIVITY

If the machine has to remain inactive for a long period:

- Close the cock Ref. 1 Fig. 23.
- Depressurise the dryer by pressing the "TEST" condensation emptying button (for about 10-20 seconds) Ref. 3 Fig.22
- Switch off the machine with pushbutton Ref. 4 Fig. 23: In this way, the machine stops after 30 seconds of idle running.
- Disconnect the power supply by means of the disconnecter switch, Ref. 5 Fig. 23 (compressor) and Ref. 6 Fig. 23 (on the dryer if fitted).
- Release pressure from the machine by turning on the cocks Ref. 7 Fig. 23 under the air vessel.
- Close the cocks Ref. 7 Fig. 23 off again after discharging all the residual air pressure.

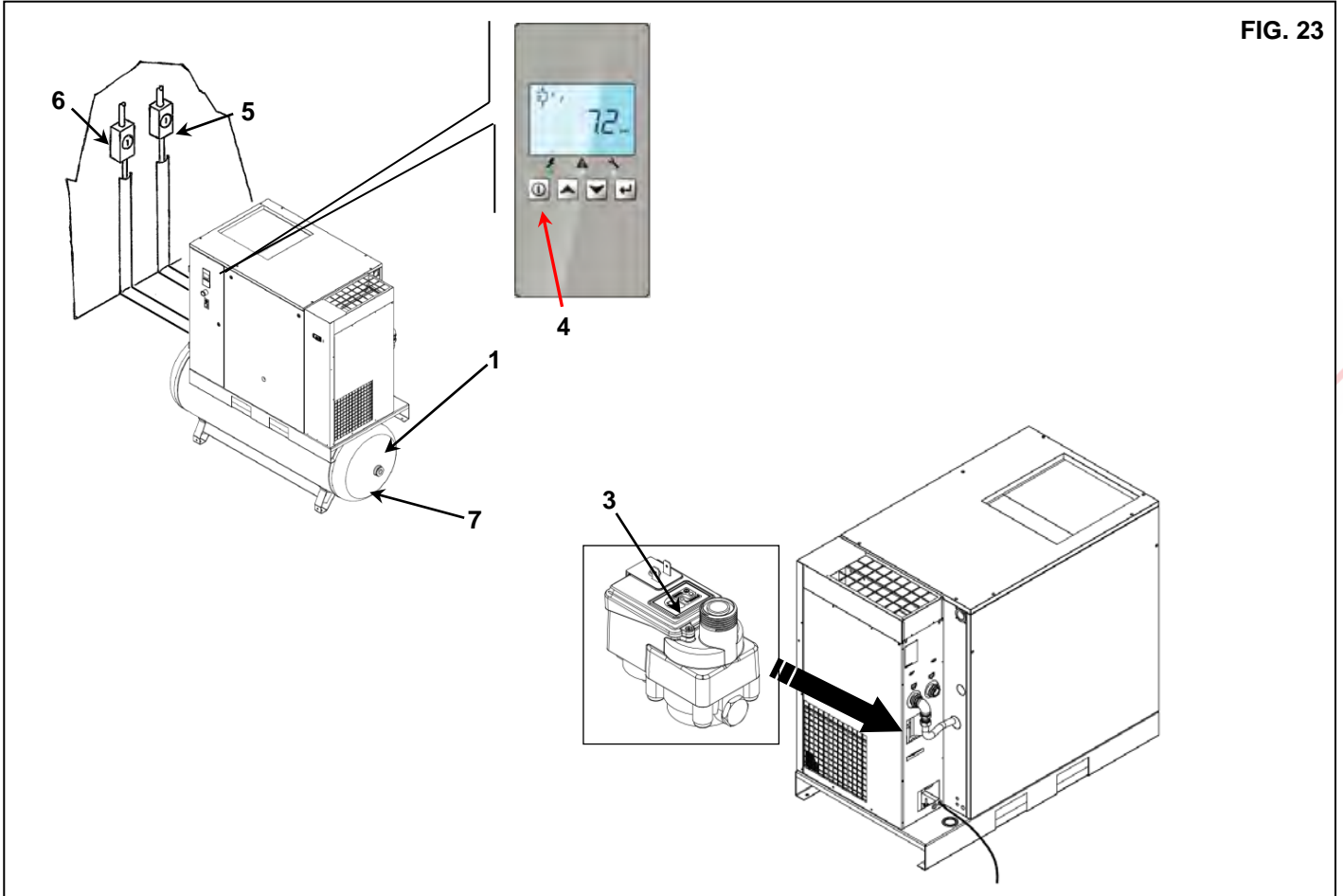

During periods of inactivity, the weather must be protected against atmospheric agents, dust and humidity, which could damage the motor and the electrical system.

To restart the machine after periods of inactivity, consult the manufacturer.

## 17.0 SCRAPPING THE UNIT

If the machine is to be scrapped, it must be dismantled into parts of the same material, to be disposed of according to the local regulations in force.



**ALWAYS RESPECT THE REGULATIONS IN FORCE FOR DISPOSING OF OLD OIL AND OTHER POLLUTING MATERIALS SUCH AS SOUND-DEADENING, INSULATING FOAM, ETC.**

## 18.0 LIST OF SPARE PARTS FOR ROUTINE MAINTENANCE

Rif	DENOMINATION	Code	HP 20 KW 15			HP 25 KW 18,5			HP 30 KW 22			HP 40 KW 30		
			8 bar	10 bar	13 bar	8 bar	10 bar	13 bar	8 bar	10 bar	13 bar	8 bar	10 bar	13 bar
1	Suction air filter	6211472350	■	■	■	■	■	■	■	■	■			
2	Oil filter	6211472250	■	■	■	■	■	■	■	■	■			
3	Separator cartridge	6221372450	■	■	■	■	■	■						
3	Separator cartridge	6221372550							■	■	■			
4	Filtering element	2202260065	■	■	■	■	■	■	■	■	■			
-	Oil	(*)	■	■	■	■	■	■	■	■	■			

(\*) Please contact your Quincy compressor dealer for oil replacement.

FIG. 24

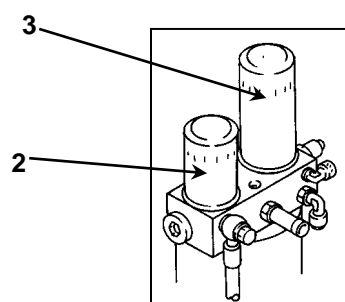
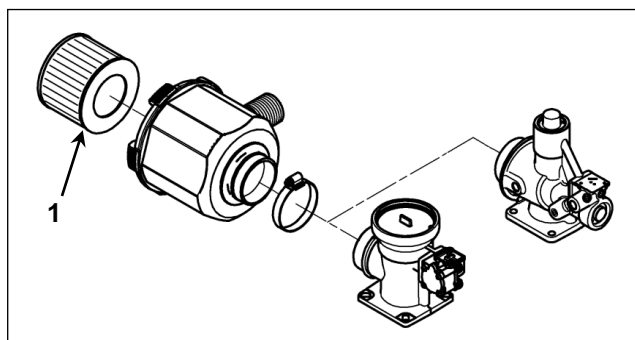
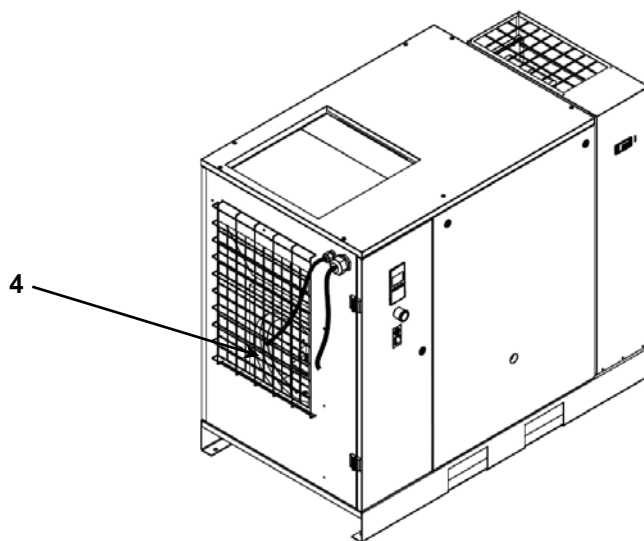



## 19.0 TROUBLE-SHOOTING AND EMERGENCY REMEDIES

N.B. OPERATIONS MARKED ■ ■ MUST BE CARRIED OUT BY PROFESSIONALLY SKILLED PERSONNEL APPROVED THE MANUFACTURER



PROFESSIONALLY SKILLED PERSONNEL MUST CARRY OUT ALL WORK. BEFORE CARRYING OUT ANY MAINTENANCE JOBS, IT IS OBLIGATORY TO STOP THE MACHINE AND DISCONNECT IT FROM THE POWER MAINS.

### 19.1 TROUBLE-SHOOTING AND EMERGENCY REMEDIES FOR SCREW COMPRESSOR

FAULT FOUND	POSSIBLE CAUSES	OBSERVATIONS
1) The machine does not start	1A - no power 1B - the transformer protection device has tripped	- check the power supply line, Chapter 12.2 - replace fuses
2) The machine does not start The red LED (Ref. 5 Fig. 17/A) is flashes. The following pictograph appears intermittently:  	2A - Phases incorrect 2B - the main motor protection device has tripped 2C - Temperature switch on element outlet has tripped	- Verify phase sequence - to check possible motor failure  - environment temperature too high; improve ventilation in the compressor room, Chapter 9.2 ■ ■ - cooling radiator is dirty, clean the radiator - oil level too low; top up the oil tank
3) The machine does not start The red LED (Ref. 5 Fig. 17/A) is flashes. The following pictograph appears intermittently:  	3A - The oil high temperature protection has tripped	- environment temperature too high; improve ventilation in the compressor room, Chapter 9.2 ■ ■ - cooling radiator is dirty, clean the radiator - oil level too low; top up the oil tank
4) The compressor does not reach working pressure	4A - the compressed air consumption is too high 4B - the discharge electro valve remains closed.	■ ■ - check the electric system
5) Excess oil consumption	5A - deteriorated oil separating filter oil level is too high	■ ■ - change the oil separating filter, Chapter 23

## 19.2 TROUBLE-SHOOTING AND EMERGENCY REMEDIES FOR DRYER



**PROFESSIONALLY SKILLED PERSONNEL MUST CARRY OUT ALL WORK. BEFORE CARRYING OUT ANY MAINTENANCE JOBS, IT IS OBLIGATORY TO STOP THE MACHINE AND DISCONNECT IT FROM THE POWER MAINS.**

**N.B. OPERATIONS MARKED ■ ■ MUST BE CARRIED OUT BY PROFESSIONALLY SKILLED PERSONNEL APPROVED THE MANUFACTURER**

FAULT FOUND	POSSIBLE CAUSES	OBSERVATIONS
1) No compressed air passes through the dryer outlet	1A) The pipes are frozen inside	<ul style="list-style-type: none"> <li>■ ■ -Hot gas by-pass the bypass valve is broken or out-of-calibration</li> <li>-The room temperature is too low and the evaporators piping are obstructed with ice</li> </ul>
2) Presence of condensate in the piping's.	<p>2A) The condensate separator does not work correctly</p> <p>2B) The dryer is working outside its rating</p> <p>2C) The dryer is working under bad excessive conditions.</p>	<ul style="list-style-type: none"> <li>■ ■ -Check the solenoid exhaust valve</li> <li>■ ■ -Check the drainage timer</li> <li>-Check the flow rate of treated air</li> <li>-Check the room temperature</li> <li>-Check the air temperature at the drier inlet.</li> <li>-Clean the condenser.</li> <li>■ ■ -Check dryer fan operation.</li> </ul>
3) The compressor head is very hot	<p>Make reference to 2B</p> <p>Make reference to 2C</p> <p>3A) The cooling circuit is not working with the right gas charge</p>	<ul style="list-style-type: none"> <li>■ ■ -Check if there are leaks of refrigerating gas.</li> <li>■ ■ - Charge it again.</li> </ul>
4) Motor cuts out on overload	<p>Make reference to 2B</p> <p>Make reference to 2C</p> <p>Make reference to 3A</p>	
5) The motor hums and does not start.	<p>The line voltage is too low.</p> <p>The starting system of the motor is defective.</p>	<p>-Contact the electric power company</p> <ul style="list-style-type: none"> <li>■ ■ - Check the running capacitor</li> </ul>
6) The machine has stopped and does not restart even after a few minutes.	<p>The overload protection with has intervened: make reference to 2B-2C-3A.</p> <p>The motor has burnt out.</p>	
7) The compressor is very noisy.	Troubles with the internal mechanical parts or with the valves	



# PART "B"

THIS PART "B" OF THE INSTRUCTIONS MANUAL IS RESERVED FOR PROFESSIONALLY SKILLED PERSONNEL APPROVED THE MANUFACTURER

## 20.0 STARTING UP

 BEFORE CARRYING OUT ANY OPERATION ON THE MACHINE, ENSURE THAT THE ELECTRIC POWER SUPPLY HAS BEEN DISCONNECTED.

### 20.1 PREPARING FOR SETTING UP

After checking everything as indicated in Chap. 12.0, (installation) follow the instructions

- Remove the brackets that hold the compressor-motor group to the base. These brackets, which are painted red, are required only during transport. The brackets may be removed with a spanner (size 13).

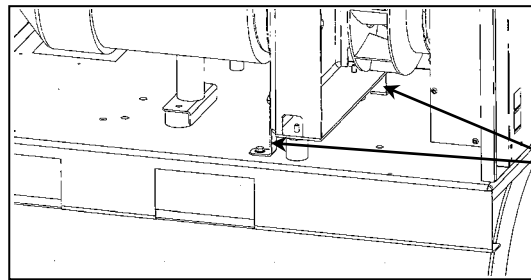

N° 2 Brackets for transport only

### 20.2 PRELIMINARY CHECKS

Check the oil level Ref. 1 Fig. 25; when delivered the machine is filled with oil; if the oil level is not as intended, top up with the same oil as the original type. If more than 3 months have passed between the inspection in the factory and the date of installation, lubricate the screw group before starting up, following the procedure described below:

- Remove the cover Ref. 2 Fig. 25
- Remove the air filter Ref. 3 Fig. 25
- Pour a little oil into the suction unit.
- Reassemble the air filter Ref. 3 Fig. 25
- Reassemble the cover Ref. 2 Fig. 25

If more than, 6 months have passed between the inspection in the factory and the date of installation, consult the manufacturer.

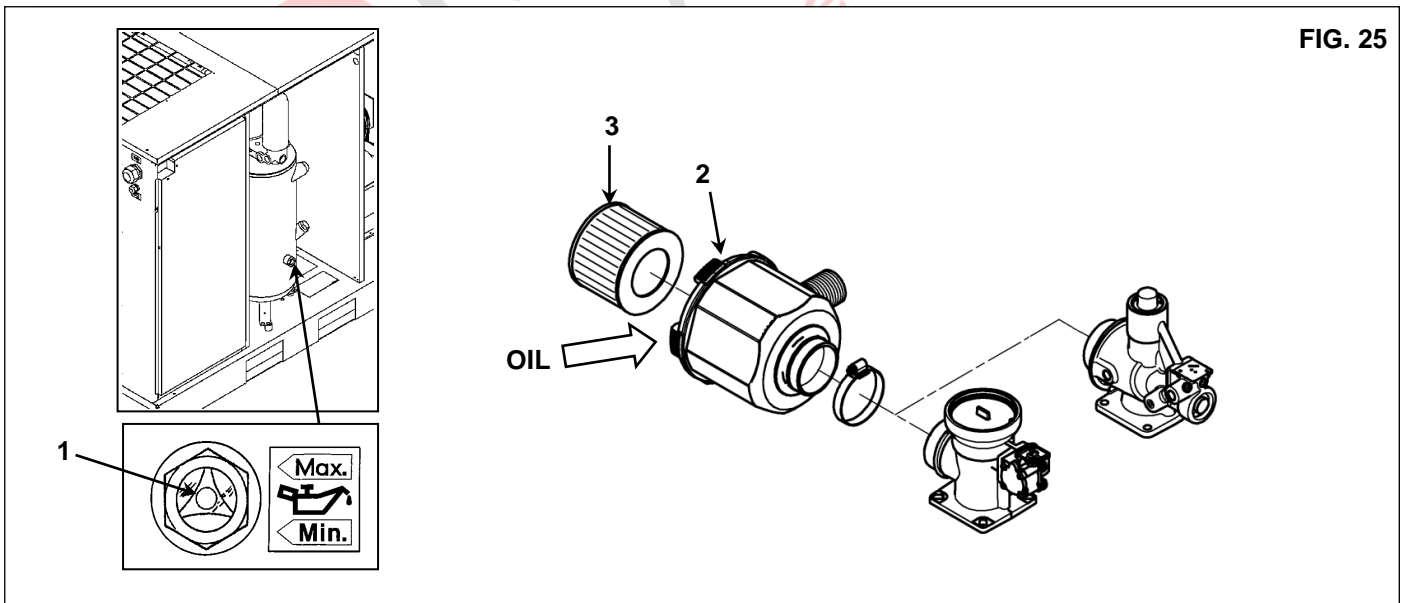



### 20.3 CHECK THE DIRECTION OF ROTATION

- Check that all fixed guards are in their correct position.
- Connect the control board to the power supply with the automatic circuit-breaker switch of the line Rif. 1 Fig. 26.
- Start up the compressor by pushing button Rif. 2 Fig. 26 for 3 seconds then release the button and push once it again after 5 seconds.
- If the rotation is correct, the compressor will start correctly.
- If the rotation is not correct, the compressor will not start and the related alarm will be shown in the controller display (See cap. 14.3.7).

 **PROFESSIONALLY SKILLED PERSONNEL MUST CARRY OUT ALL WORK ON THE ELECTRIC PLANT, HOWEVER SLIGHT.**

- Disconnect the energy supply and invert two connections as per Ref. 1 Fig. 26
- **IT IS ADVISABLE NOT TO DO ANYTHING ON THE MACHINE PANEL**

IF ALL THE INSTRUCTIONS FOUND IN THIS MANUAL HAVE BEEN OBSERVED THE MACHINE CAN BE STARTED.

 **ATTENTION: wait at least 45 seconds before starting the machine after a switch off**

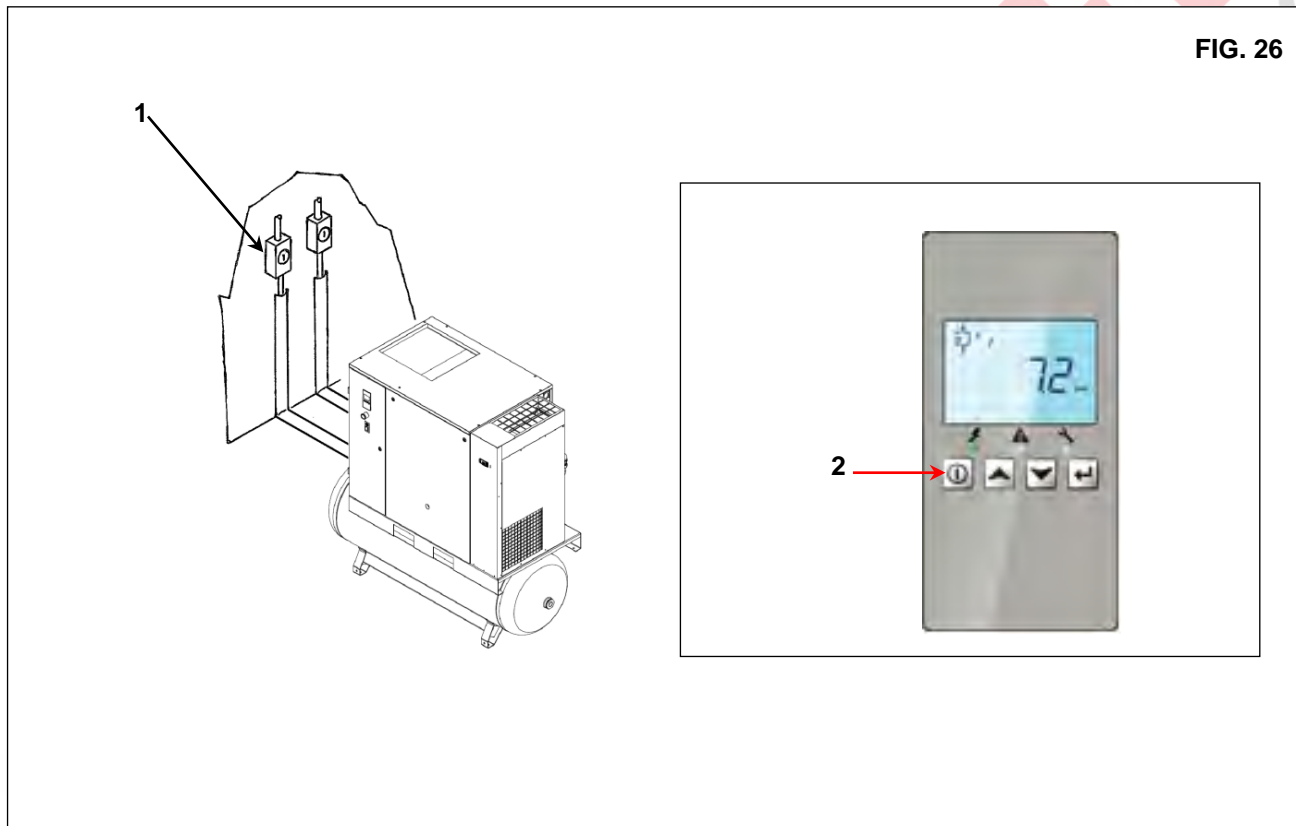

## 21.0 GENERAL ORDINARY MAINTENANCE REQUIRES TRAINED PERSONNEL



**BEFORE CARRYING OUT ANY MAINTENANCE JOBS, IT IS OBLIGATORY TO STOP THE MACHINE AND DISCONNECT IT FROM THE POWER MAINS.**

### MAINTENANCE SCHEDULE

These maintenance intervals are recommended for work environments that are not dusty and are well ventilated. For particularly dusty environments, double the frequency of controls.

Every Day (after use)	■ ■	Drain condensate from the air tank Check automatic condensation emptying
Every 50 working hours	■ ■	Drain condensate from the oil collector Check the oil level Clean the filtering panel
Every 500 hours	■ ■	Clean the air suction filter Clean the condenser battery (on the dryer if fitted) Clean the dirt collection filter Fixing electrical cables (at first 500 hrs)
Every 2000 hours (or at least every year)	■ ■ ■ ■	Change the oil Change the oil filter Change the suction filter Change the filter mesh of dryer condensate drain Retighten all power cable connections Safety temperature test Check belt tension
Every 4000 hours (or at least every 2 years)	■ ■ ■ ■	Clean the finned surface of the air-oil cooler Change the oil separating filter Service kit for dryer condensate drain Change the filter panel Replace the belts Replace the line afterfilter (change the filter cartridge at least once a year)
Every 8000 hours (or at least every 3 years)	■ ■ ■ ■	Service kit for non-return valve Change the dryer condensate drain Service kit for minimum pressure valve and thermostatic valve Kit revision intake valve Checking the status of the oil return valve and oil pipes
Every 24000 hours	■ ■ ■ ■	Kit revision of the compressor unit Service kit Motor (bearings)

**N.B.: THE OPERATIONS MARKED ■ ARE DESCRIBED IN PART "A" OF THIS MANUAL ON CHAPTER 15.2**

## 22.0 CHANGING THE OIL

**BEFORE CARRYING OUT ANY MAINTENANCE JOBS, IT IS OBLIGATORY TO STOP THE MACHINE AND DISCONNECT IT FROM THE POWER MAINS AND FROM THE COMPRESSED AIR DISTRIBUTION NETWORK.**

Oil changing is an important operation for the compressor:

If the lubrication of the bearings is not efficient, the compressor life will be short.

The oil must be changed when the machine is still warm, that is immediately after stopping it.

The suggestions listed below should be scrupulously followed.

After draining the old oil out of the machine Ref. 2 Fig. 27.

- Completely fill the oil collector Ref. 1 Fig. 27.

- Pour a little oil into the suction unit.

- Start the compressor.

- After about 1 minute switch off the machine by pressing "STOP" (Ref. 3 Fig. 27) after 30 seconds of idle running the machine will switch off.

**PROCEED AS DESCRIBED AT POINT CHAPTER 15.4**

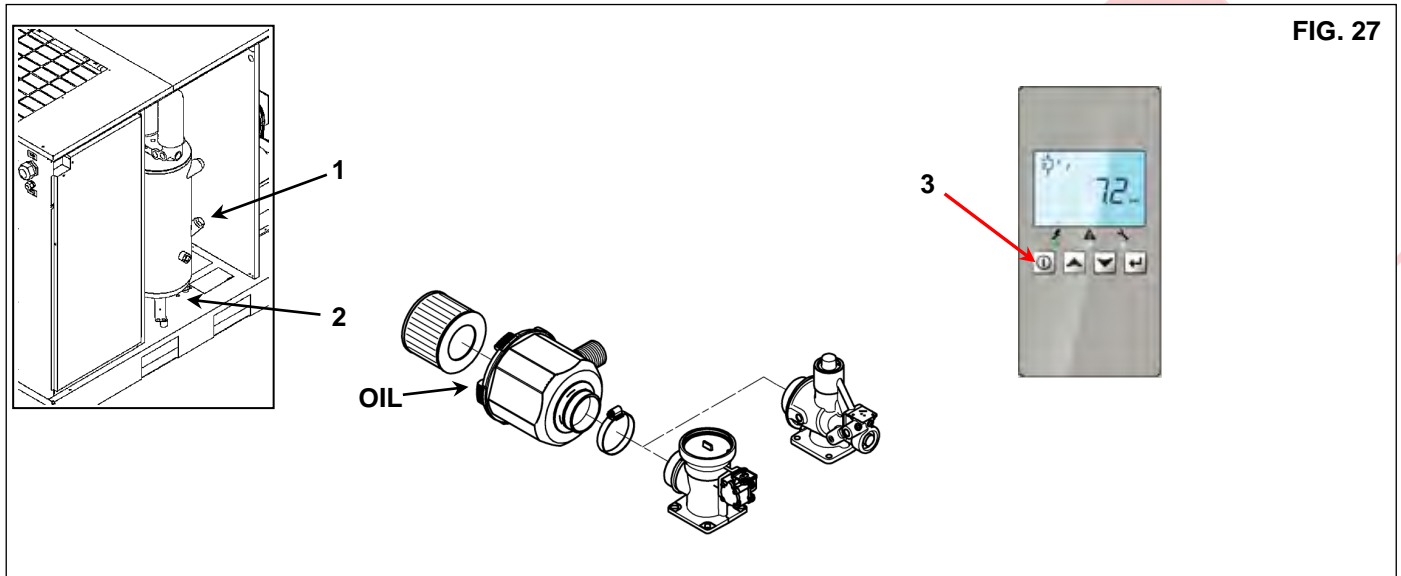

**THE OLD OIL MUST BE DISPOSED OF IN COMPLIANCE WITH THE REGULATIONS IN FORCE.**

### NOTE ON LUBRICANTS

When delivered the machine is filled with oil.

In normal conditions of use, these lubricants have proved to be able to withstand use for as many as 4.000 hours. However, due to the external polluting agents that get into the compressor with the air that it takes in, it is advisable to change the oil at more frequent intervals, as indicated on the routine maintenance chart. If the compressor is being used at high temperatures (continuous operation above 90 °C) or in particularly severe conditions, we advise changing the oil at shorter intervals than those recommended in the maintenance chart.

**DO NOT TOP UP WITH DIFFERENT OILS**

### 23.0 REPLACE THE DE-OILER FILTER AND THE OIL FILTER



BEFORE CARRYING OUT ANY MAINTENANCE THE MACHINE MUST BE STOPPED, CUT OFF THE MACHINE FROM THE ELECTRICAL MAINS AND FROM THE COMPRESSED AIR DISTRIBUTION CIRCUIT, CHECK THAT THE MACHINE IS NOT UNDER PRESSURE.

Before proceeding with the replacement of the de-oiler filter or the oil filter check that there is no pressure in the machine: check the pressure gauge Ref. 1 Fig. 28.

- Lubricate the filter seals with a little oil before fitting.
- Tightening must be done by hand.

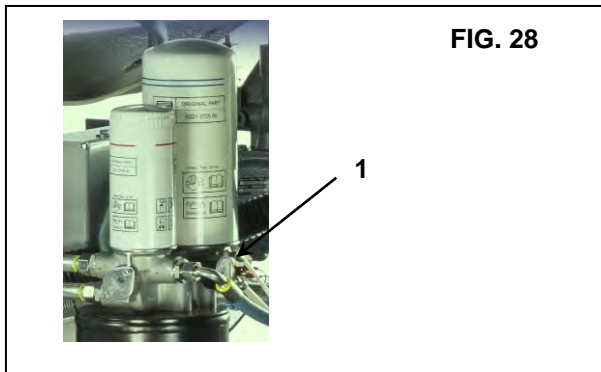

FIG. 28

### 24.0 BELT TENSION



BEFORE CARRYING OUT ANY MAINTENANCE THE MACHINE MUST BE STOPPED, CUT OFF THE MACHINE FROM THE ELECTRICAL MAINS AND FROM THE COMPRESSED AIR DISTRIBUTION CIRCUIT, CHECK THAT THE MACHINE IS NOT UNDER PRESSURE.

#### Tightening or retightening new belts

Proceed as follows:

- Remove the back panel
- Remove the pulley protection plate
- Unlock the screws A (x4) (Fig 29).
- Adjust the belt tension by turning the screws B (x2) (Fig 29)
- Lock the screws A (4x) again
- Refit the pulley protection plate and the back panel

HP 20-25-30-40  
KW 15-18,5-22-30

1 -  $F = 50N.m$ , force to be applied at the centre line, at right angles to the new belt.

2 -  $f = 7,2 mm.$ , clearance after the application of  $F$ . (after 100 h operation  $f = 11,7 mm.$ )

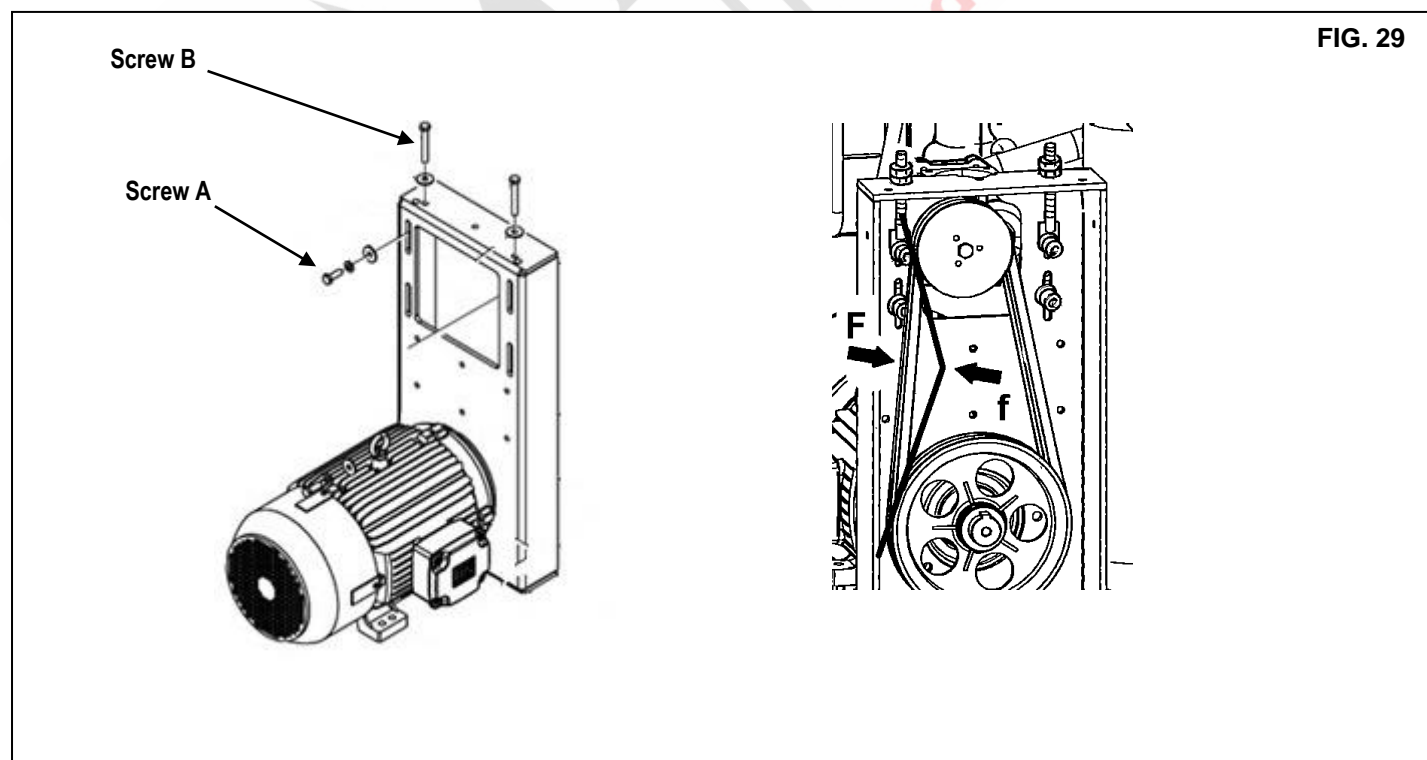

FIG. 29

## 25.0 REPLACING THE ELECTRIC MOTOR



**BEFORE CARRYING OUT ANY MAINTENANCE THE MACHINE MUST BE STOPPED, CUT OFF THE MACHINE FROM THE ELECTRICAL MAINS AND FROM THE COMPRESSED AIR DISTRIBUTION CIRCUIT, CHECK THAT THE MACHINE IS NOT UNDER PRESSURE.**

### 25.1 DISASSEMBLING THE COOLING FAN AND CONVEYOR (Fig. 30)

Proceed as follows:

- Remove the external panels.
- Remove the pulley guard.
- Block the rotation of the motor.
- Unscrew the fan fastening screw Ref. 2 (\*), use a spanner with an extension.
- Remove the cooling fan Ref. 3.

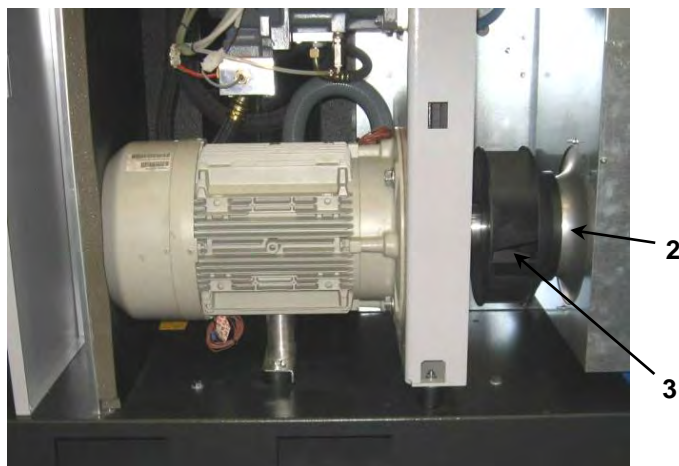

FIG. 30

### 25.2 DISASSEMBLING THE ELECTRIC MOTOR (Fig. 31)

Remove the cooling fan. (See Cap. 25.1)

- Slacken the screws A (\*\*).
- Slacken the screws B
- Remove the transmission belts
- Remove the motor pulley (see figure A)
- Disconnect the electric cables Ref. 10
- Loosen the supporting pad Ref. 11.
- Remove the screws Ref. 12 (\*\*\*), fastening motor.
- Extract the motor Ref. 13.

FIGURE A

T-Bush	Tightening torque (N.m)
1610	20
2012	31
2517	48

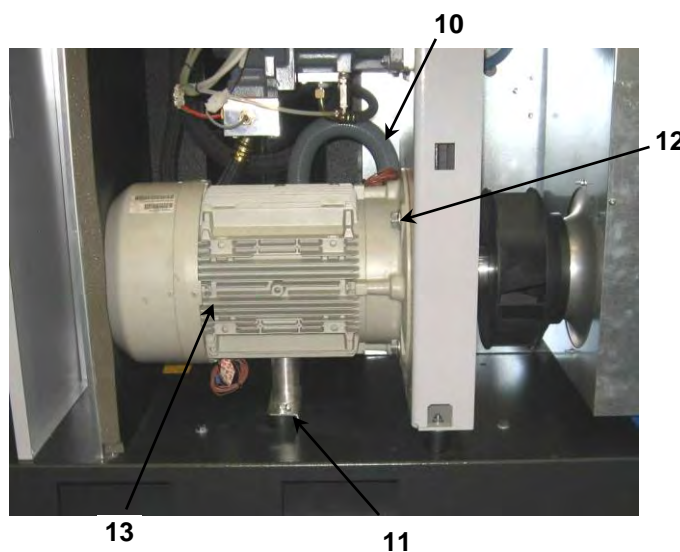
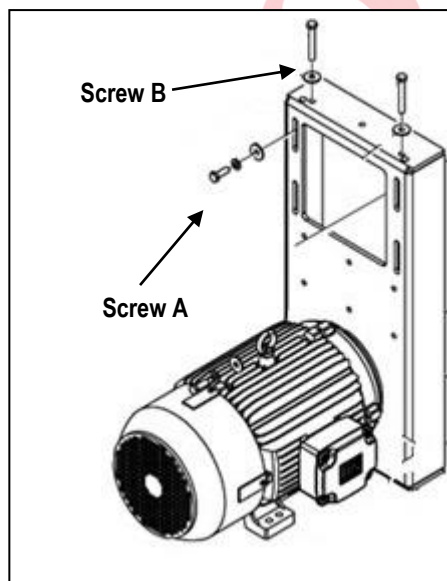
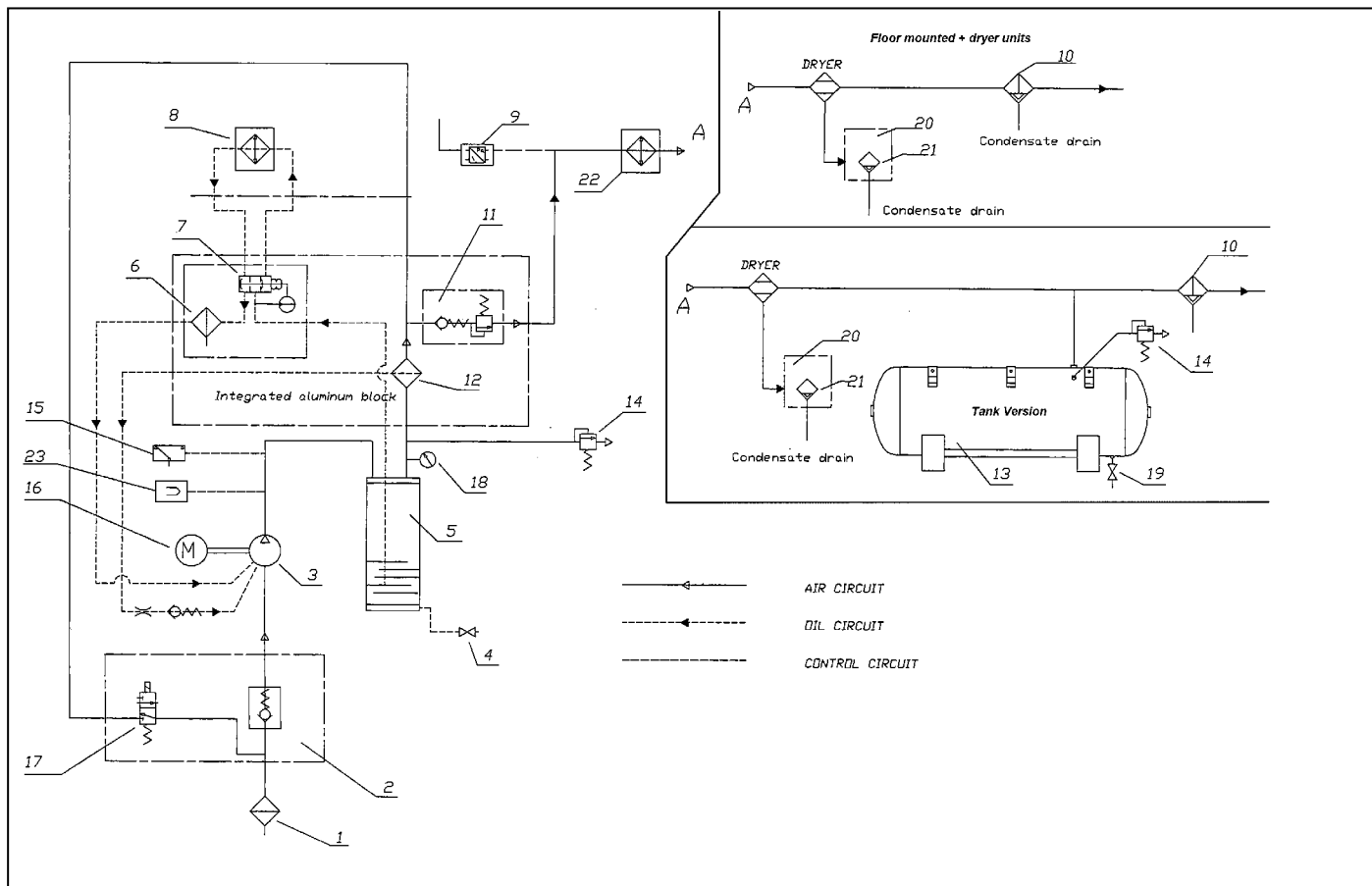

FIG. 31

- (\*) Tightening torque = N.m 160
- (\*\*) Tightening torque = N.m 55
- (\*\*\*) Tightening torque = N.m 160



## 26.0 OLEOPNEUMATIC DIAGRAM



1 AIR FILTER	13 AIR VESSEL
2 REGULATING VALVE	14 SAFETY VALVE
3 COMPRESSOR	15 SAFETY THERMOSTATIC
4 OIL DRAIN	16 ELECTRIC MOTOR
5 AIR-OIL RECEIVER	17 NO-LOAD RUNNING SOLENOID VALVE
6 OIL FILTER	18 MANOMETER
7 THERMOSTATIC VALVE	19 MANUAL DRAIN VALVE
8 OIL COOLER	20 IMPURITY TRAP
9 PRESSURE SENSOR	21 CONDENSATE ELECTRONIC DRAIN VALVE
10 AIR LINE FILTER	22 AIR COOLER
11 MINIMUM PRESSURE VALVE	23 TEMPERATURE SENSOR
12 AIR-OIL SEPARATOR	

## 27.0 CALIBRACION FOR DRYER

### BYPASS VALVE FOR HOT GAS

N.B. These valves have already been calibrated and they do not require any adjustment. A dew point different from the rated one generally depends on causes which are not attributable to their operation.

- 1) Closing cap
- 2) Adjusting screw

### WORKING PRESSURES AND TEMPERATURES OF R410a

SUCTION SIDE OF REFRIGERATION COMPRESSOR		
	Evaporat. Temperat. °C	Evaporating Pressure bar
RATED VALUES (Temperat. 20 °C)	1 ± 2	R410A 7,28 ± 7,55

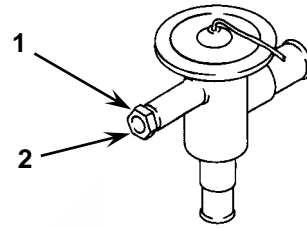

### 27.1 FLOW DIAGRAM OF THE DRYER

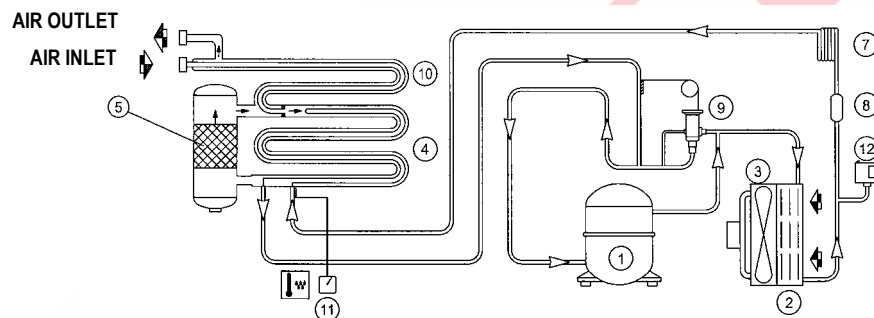

1 COMPRESSOR	8 REFRIGERANT FILTER
2 CONDENSER	9 HOT GAS BYPASS VALVE
3 MOTOR FAN	10 AIR-TO-AIR EXCHANGER
4 EVAPORATOR	11 DEW POINT THERMOMETER
5 SEPARATOR	12 FAN PRESSURE SWITCH
7 EXPANSION CAPILLARY TUBE	

**COMPRESSED**  
AIR ADVISORS

Inc.

**Compressed Air Advisors, Inc.**

Phone: 877.247.2381

[info@compressedairadvisors.com](mailto:info@compressedairadvisors.com)

[www.compressedairadvisors.com](http://www.compressedairadvisors.com)