

AXIOM

POWER AMP EMULATOR PAE-1

TECHNICAL TIPS

The AXIOM Power Amp Emulator PAE-1 is designed to take the place of a tube power amp. It can't replicate the physical impact of big speakers moving air and vibrating the floor, but it can produce the crunch, compression and sustain power tubes are famous for... at lower volumes and without the expense, size, weight and maintenance. As such, it is designed to be placed after a preamp or overdrive type pedal. You can use it with an instrument plugged straight in, but it will be similar to plugging directly into an amp's effects loop return or "power amp in" jack. The PAE-1 can also be used not only for instruments but to add tube power amp flavour to any signal.

The following are some technical tips that expand upon the PAE-1 User Manual. As the PAE-1 uses a topology analogous to tube amps, terms such as "phase inverter", "power tubes" and "output transformer" are used to describe the corresponding solid-state analog sections in the PAE-1 as well as in tube amps. Figures 1 and 2 depict push-pull and single-ended tube power amps, respectively, for reference.

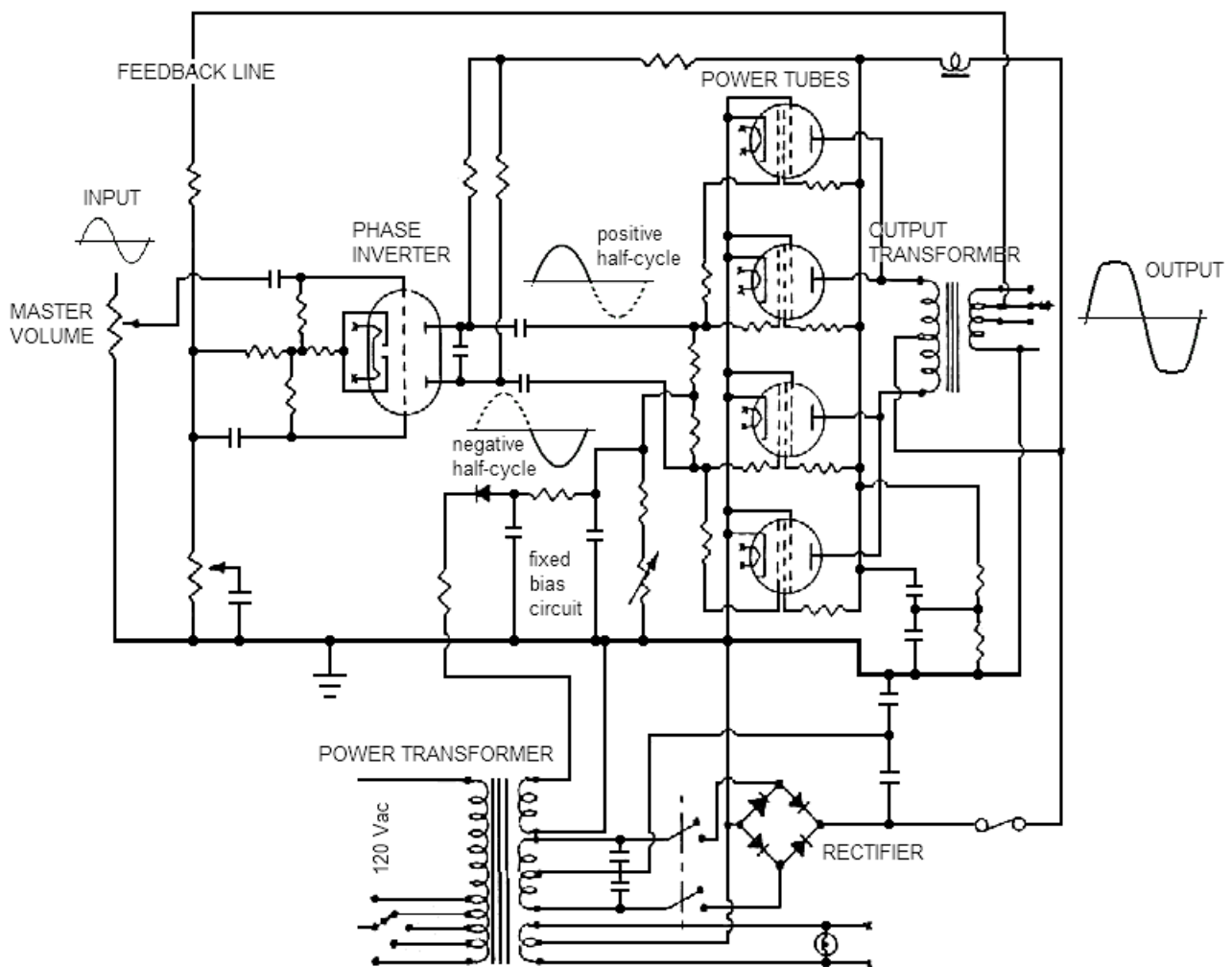

Figure 1. Push-Pull Tube Power Amplifier.

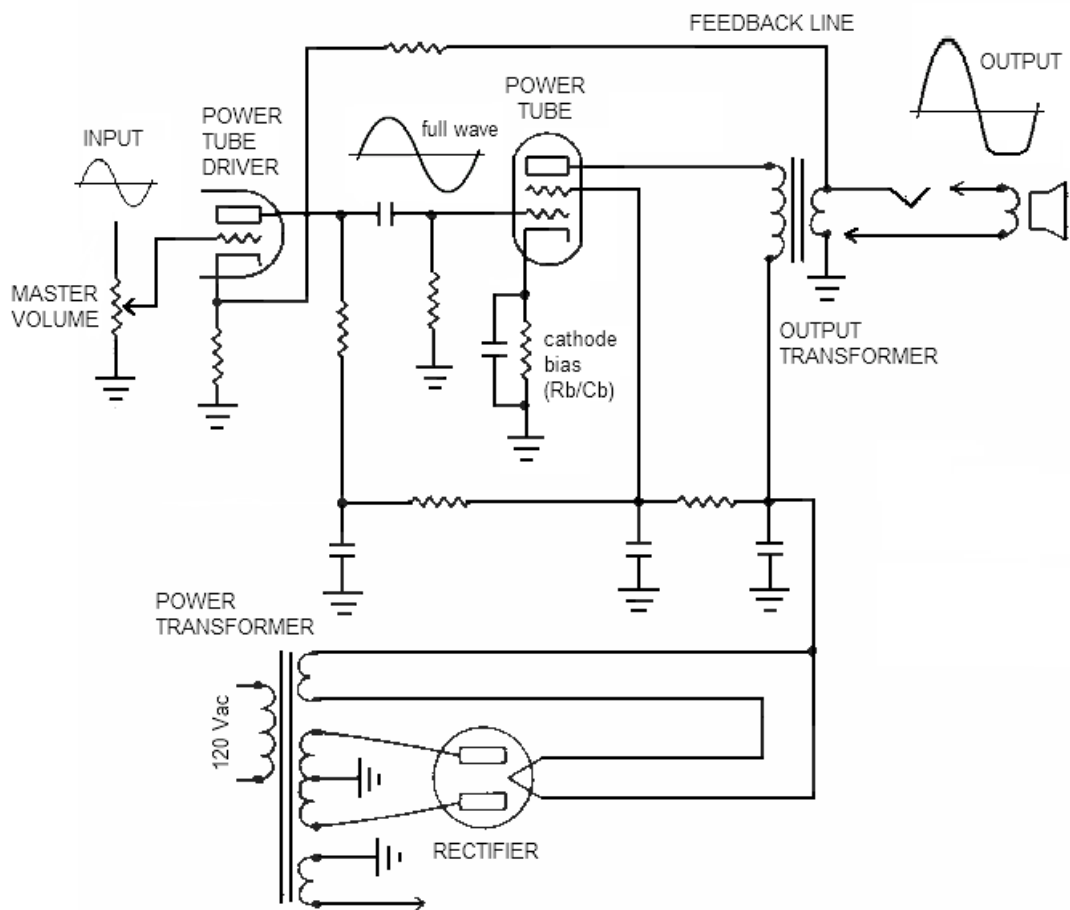

Figure 2. Single-Ended Tube Power Amplifier.

POWER AMP EMULATOR PAE-1 CONTROLS

Fixed Bias/Cathode Bias switch: Power tubes can be configured in fixed bias or cathode bias. In fixed bias a dc voltage is applied to the tube grid to set the bias current level (“fixed bias circuit” in Figure 1). In cathode bias a resistor and capacitor on the tube’s cathode is used to set the bias current level (“Rb/Cb” in Figure 2). Cathode biased stages develop a voltage across their cathode bias resistor as current flows through the tube. This reduces the total voltage developed across the tube and causes a slight power output drop. It also varies as current flows through the tube and shifts the operating point of the tube, causing compression and harmonic distortion. For these reasons, fixed biased amps are known as being “firmer” and cathode biased amps as being “squishier”, particularly in response to hard string strikes at loud volumes.

Push-Pull/Single-Ended switch: Power amps can be configured as push-pull or single-ended. Push-pull amps use different tubes for the positive and negative portions (half-cycles) of the output signal, with each tube amplifying one-half of the signal waveform and the entire waveform then being reconstructed at the output transformer (see Figure 1). This results in a symmetrical output waveform because both positive and negative half-cycles of the wave are amplified identically (at least, in a perfect world). Single-ended amps’ output tubes each amplify the entire signal and since even centrally biased tubes cannot amplify the entire wave perfectly symmetrically, they produce an asymmetric output dependent on the

tube's characteristic curve (See Figure 2). Part-for-part, push-pull amps are more efficient, produce higher power outputs and have more clean headroom than single-ended amps.

As a consequence of their output being symmetrical, push-pull amps produce no even-order harmonics and only odd-order harmonics through their power tubes (ideally). This is part of their "biting" overdriven sound. Single-ended amps, however, produce a noticeably asymmetric output as they are driven closer to their clean headroom limits (as they start to distort or "overdrive"). The further they are biased away from perfect central biasing, the more asymmetric clipping and even-order harmonics they produce. This is a major part of the single-ended or "Class A" sound.

NOTE: Class A amplifier operation refers to a bias condition where the output tube(s) is biased so as to amplify the entire waveform. All single-ended amps are designed to operate as Class A, though shifting the bias point will alter how symmetrically or asymmetrically they clip as they are overdriven.

Class AB amplifier operation refers to a bias condition where the output tubes are biased so they amplify only a portion of the waveform and shut off during the rest. The output signal is then made by combining all the tubes' outputs at the output transformer to produce the full waveform. Push-pull amps typically operate in Class AB, though they can be biased to operate in Class A if the bias circuitry is designed to allow it.

MASTER: As in a tube amp, the MASTER volume control in the PAE-1 is located right before the "phase inverter" section. Cranking the MASTER drives not only the "phase inverter" harder but also everything down the line (i.e. the "power tubes"). In "Single-Ended" mode the MASTER control is analogous to controlling the signal level hitting the "power tube driver" (See Figures 1 and 2).

FEEDBACK: The FEEDBACK control in the PAE-1 is implemented the same way as the negative feedback line in a tube power amp - a portion of the output signal is fed back to the "phase inverter" (or, in the case of a single-ended amp, the preamp tube before the power tube) in reverse polarity to the audio signal. Doing this reduces distortion and improves the linear response of the amp. Decreasing the amount of negative FEEDBACK increases distortion and early break-up but can also produce "fizz" as there is no deliberate tone filtering after this point in an amp to compensate.

POWER: Decreasing the POWER control has a host of effects on the behaviour of the PAE-1. As POWER is decreased clean headroom decreases, output level decreases, compression increases and the effects of SAG, TUBE and FEEDBACK are reduced. This is also a case where some of the PAE-1 settings can have no real-world counterparts. For instance, there is no such thing as a 5-Watt push-pull amp using 6L6 power tubes. If you set the PAE to such a setting you can think of it as a sort of "what if" situation.

ATTEN: Attenuators are often used to decrease the volume of a cranked amp. An attenuator sits between the amp's output and the speakers and bleeds off some of the power so the signal is quieter. This is done, rather than simply turning down the master volume, so the power amp can be driven harder into its "sweet spot" without deafening volume levels. The ATTEN control in the PAE-1 is simply a reverse level control at the output of the circuit. It is after the "power amp", before the speakers, and reduces signal level as the knob is turned clockwise, so it is labelled "ATTEN".

BIAS: Emulates cold (-) to hot (+) power tube bias. In tube amps “cold” bias refers to a lower bias current at idle and “hot” bias refers to a higher idle current. Biasing cold in both Single-Ended and Push-Pull configurations increases asymmetric clipping and even-order harmonic content. Biasing hotter produces a thicker, fuller sound; biasing colder can add “bite”.

Biasing too cold in Push-Pull configuration will, as in a tube amp, result in “crossover” distortion. This corresponds to the situation where the positive and negative half-cycles from the phase inverter do not recombine in perfect alignment at the output transformer. Instead of a smooth recombined wave there are kinks at the crossover points. This produces a very characteristic “broken” sounding distortion, though small amounts of crossover distortion can be used to produce a more biting, “raw” tone. Power pentode tubes (such as EL34, EL84, etc) tend to naturally produce more crossover distortion than beam tetrode tubes (such as 6L6, 6V6, etc). This is part of the reason they’re known sounding “grittier”.

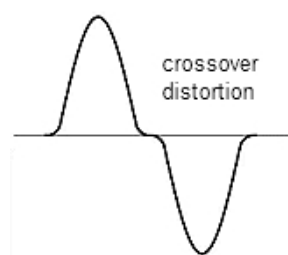

Figure 3. Crossover Distortion

Very low bias settings can yield unpredictable results in combination with certain other settings on the PAE. Bias may affect the sweep of the MASTER and PI GAIN controls. Often, this corresponds to settings that can’t really exist in the real world. (For instance, setting the PAE BIAS control fully counter-clockwise (-) in combination with “single-ended”, 5W, PI GAIN of 100.)

TUBE: The TUBE control begins with a very “firm” and clear sound in ultra-linear (UL) mode and then progresses to more dynamic headroom compression and harmonic content as the dial is rotated through the beam tetrode (6L6 and 6V6) and power pentode (EL34 and EL84) tube settings. This results in a slightly “softer” attack on the notes, particularly the lower frequencies, but also more “crunch” and compression.

Tubes operate linearly only in relatively narrow regions of their operating curves. As the tube is pushed to the outer limits of these regions it compresses the tips of the amplified waveform, first adding subtle harmonics and eventually audible distortion. The PAE-1 achieves this by dynamically mimicking the compression and headroom characteristics of an operating tube as it shifts along its load line. At first the compression is gentle but gradually turns into harder clipping as the MASTER and PI GAIN controls are turned up, or as the FEEDBACK control is turned down.

As with an actual power amp, the difference between tube type settings gets more apparent as the MASTER and PI GAIN are increased. At low MASTER and PI GAIN settings, less difference will be heard between the tube types.

RECTIFIER: As a Class AB push-pull type tube amp’s output volume is increased more current is drawn from the power supply as sounds are amplified. This increase in current demand can cause a droppage in the rectifier’s d.c. output voltage (i.e. “sag”), which then

recovers back to normal as the sound signal fades (see Figure 4). This voltage drop results in a loss of volume, lower headroom and more compression of the audio signal on loud transients, but also as a “blooming” effect as the voltage and amplification factor recovers. Traditionally, rectifiers were intended to be as “stiff” as possible but, depending on the exact design, some rectifiers can sag noticeably, particularly in higher power applications, giving the amp a soft, “spongy” feel.

The PAE-1’s RECTIFIER control replicates the rectifier response of tube amps from very stiff, though a solid-state (diode) rectifier, to a very underspec’ed and very saggy 5Y3 tube rectifier.

As with the TUBE control, the effect of the RECTIFIER setting is more pronounced as the MASTER and PI GAIN controls are increased.

NOTE: Single-Ended Class A amps sag much less than Push-Pull Class AB amps. This is because in Class A biased amps, the current draw at full power is the same as the current draw at idle (there’s no sag because the current draw doesn’t increase with volume). Some sag can appear in Class A amps when they are not truly centrally biased but it will be much less than in Class AB amps.

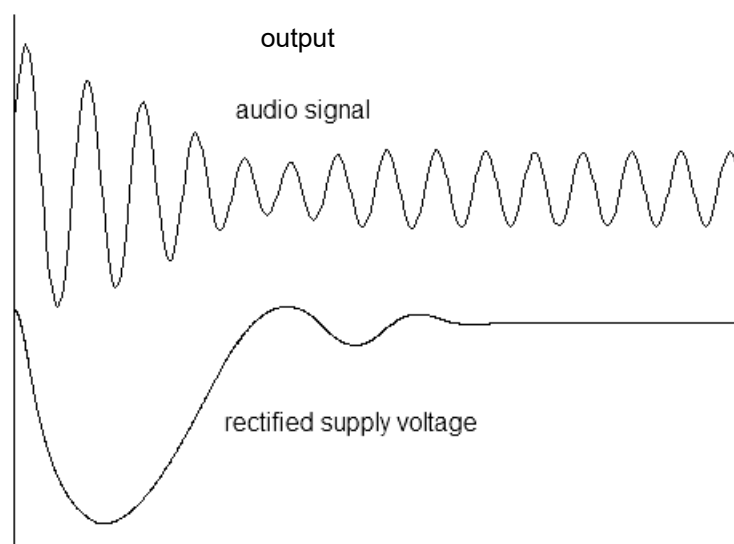

Figure 4. Rectifier Voltage Sag.

PI GAIN: Push-pull amplifiers require a phase-inverter to drive the output tubes (see Figure 1). Single-ended amplifiers have no phase inverter (1 on the PI GAIN dial) but instead rely on a “power tube driver” stage to provide the necessary signal level to drive the power tubes (see Figure 2). Phase inverter/driver tubes vary from a gain of 20 (for a 12AU7 tube) to 100 (for a 12AX7 tube). Higher gains result in less clean headroom, more power tube distortion and more sustain.

Flyback (internal trimpot): When tube power amps are connected to a speaker (or speakers) an interaction occurs between the speaker’s voice coil and the inductance of the amp’s output transformer. When the amp is generating a clean sound (not distorting) this interaction isn’t audibly noticeable. When the amp is distorting, however, flyback voltages are generated that result in spikes on the leading edges of the audio waveform (see Figure 5a).

These spikes create higher order harmonics that make the sound brighter and more distorted in the higher frequencies. As the note fades out of clipping the spikes reduce then disappear, making the sound “darken” as the note fades (see Figures 5b and c). This is part of the tube amp characteristic.

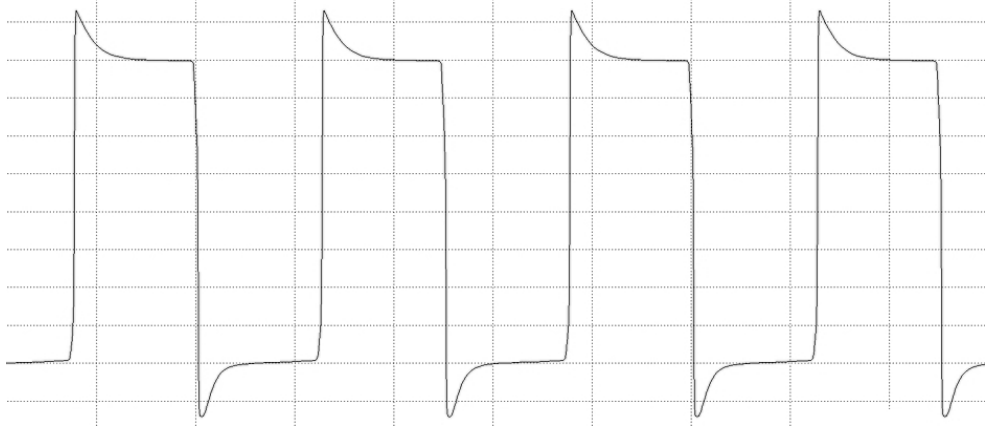
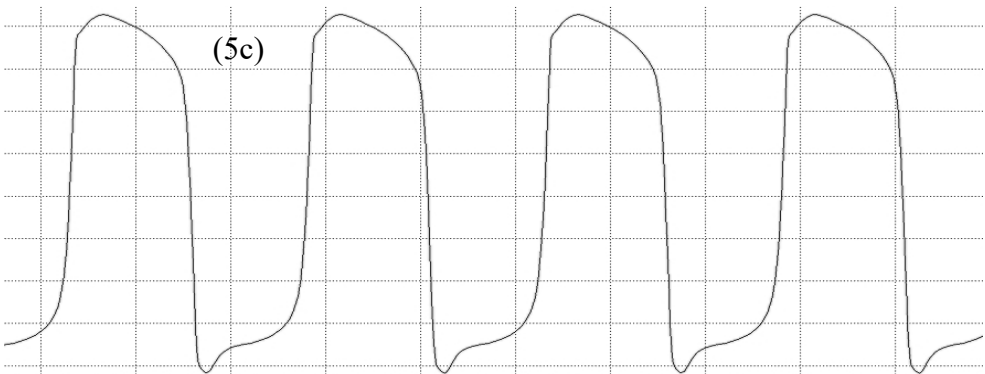
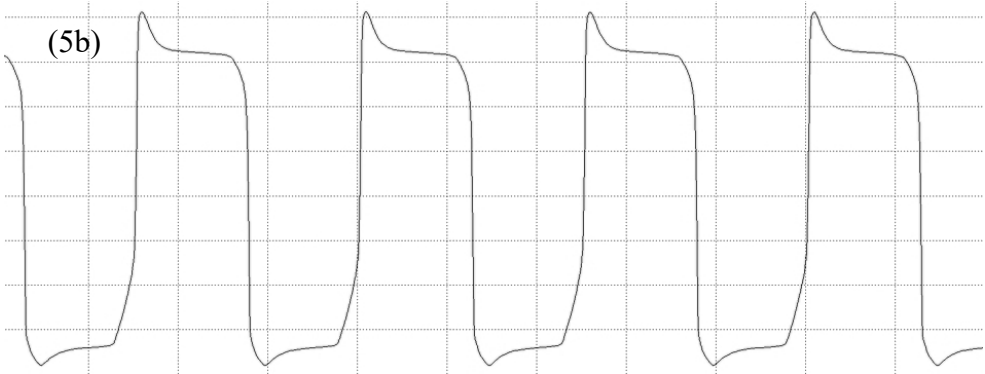

Figure 5a. Flyback Voltage Spikes, heavily clipped signal.



Figures 5b and 5c. Flyback Voltage Spikes, signal fading out of clipping.

The PAE-1 features an internal trimpot that allows the user to adjust these flyback spikes from none (like you would get from a highly damped solid-state amp or a tube amp connected to a purely resistive load like some resistive attenuators) to flyback spikes typical of a guitar speaker.

CAB (internal DIP switches): Speakers don't provide a steady dc resistance throughout their frequency range. The impedance curve of a typical guitar/bass speaker is shown in Figure 6.

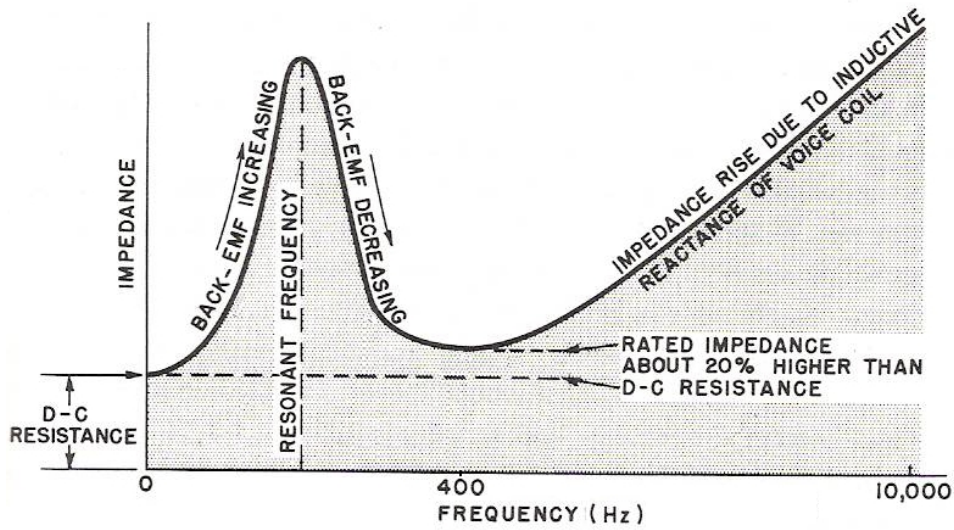

Figure 6. Speaker Impedance Curve.

From Figure 6 it can be seen that the speaker exhibits an impedance peak at its resonant frequency and impedance rises again with increasing frequency as a result of the voice coil inductance (which was addressed in the flyback voltages section above). The resonant frequency impedance peak also affects the tube power amp's response in that the back-emf generated at the speaker increases power output and volume in the resonant frequency range and also "softens" or smoothes the sharp edges of the waveform if the power amp is clipping heavily. This does not occur in solid-state amps due to their low output impedances (high damping factors), nor does it occur in tube power amps connected to a purely resistive load (like some attenuators). Figure 7 shows the response of the PAE-1 to a resistive load and at the resonant peak of a typical guitar speaker.

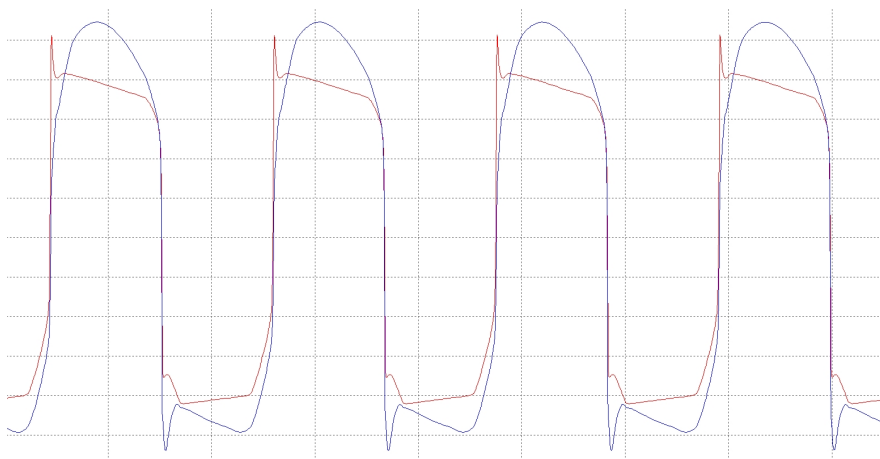

Figure 7. Response of the PAE-1 to a resistive load (red) and to a speaker load at its resonant frequency (blue).

The resonant frequency of a speaker is influenced by the type of cabinet it's in. Closed-back guitar cabs typical raise the speaker's resonant frequency by about 40 Hz. The internal DIP switches in the PAE-1 allow you to set the PAE-1 to various speaker/cabinet configurations.