

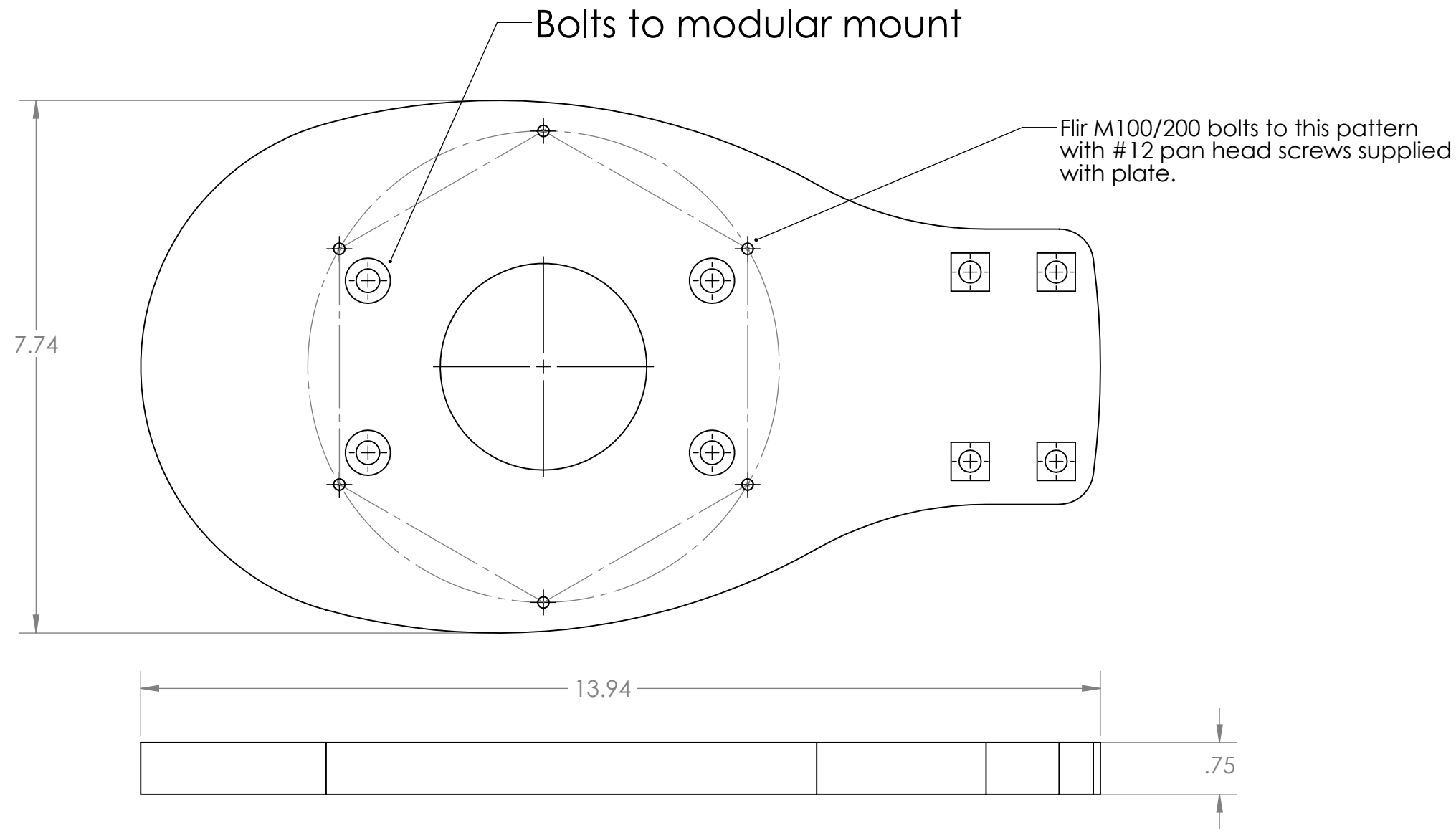

8 7 6 5 4 3 2 1

D  
C  
B  
A

D  
C  
B  
A



**PROPRIETARY AND CONFIDENTIAL**  
 THE INFORMATION CONTAINED IN THIS DRAWING IS THE SOLE PROPERTY OF SEAVIEW. ANY REPRODUCTION IN PART OR AS A WHOLE WITHOUT THE WRITTEN PERMISSION OF SEAVIEW IS PROHIBITED.

		UNLESS OTHERWISE SPECIFIED:		NAME	DATE	 TITLE: Top plate for Flir M100/200
		DIMENSIONS ARE IN INCHES	DRAWN	J.A.	01.24.19	
		TOLERANCES:	CHECKED			
		FRACTIONAL ±	ENG APPR.			
		ANGULAR: MACH ± BEND ±	MFG APPR.			
		TWO PLACE DECIMAL ±.01	Q.A.			
		THREE PLACE DECIMAL ±.003	COMMENTS:			
		INTERPRET GEOMETRIC TOLERANCING PER:				
		MATERIAL				
		FINISH				
NEXT ASSY	USED ON					
APPLICATION		DO NOT SCALE DRAWING				
SIZE	DWG. NO.	REV				
<b>B</b>	<b>ADAF2</b>	<b>A</b>				
SCALE: 1:2	WEIGHT:	SHEET 1 OF 1				

8 7 6 5 4 3 2 1