



Mounting Dream

MD2463 INSTALLATION INSTRUCTION

Für die Installationsanweisungen auf deutsch, Siehe Seite 9-10.

Pour l'instruction en français, veuillez vous reporter à la page 11~12.

Para las instrucciones de la instalación en español, favor vea la página 13~14.

Per le Istruzioni in italiano, vedi pagina 15~16.

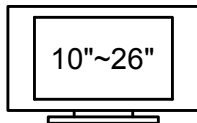
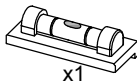
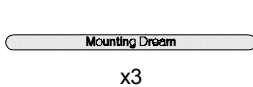
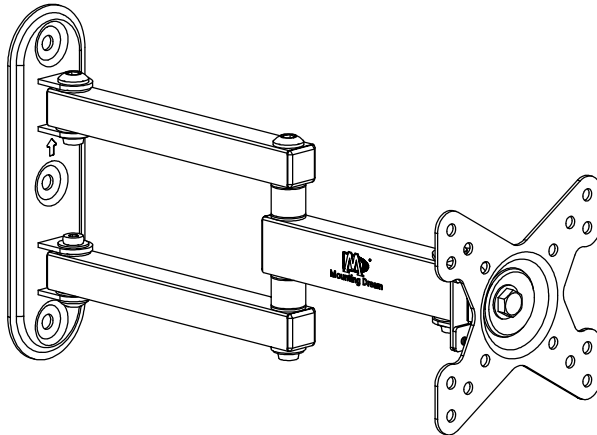

Max: 100x100mm/4x4in
Min: 50x50mm/2x2in

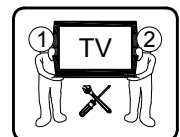

(A10)

If you have any questions, please contact us via customerservice@mountingdream.com or call us at telephone (626) 604-9048 (USA) Mon - Fri 10am - 6pm (Pacific time).

Before getting started, let's make sure this mount is perfect for you!

1 Is your TV VESA 50x50mm/2x2in, 75x75mm/3x3in, 100x100mm/4x4in?

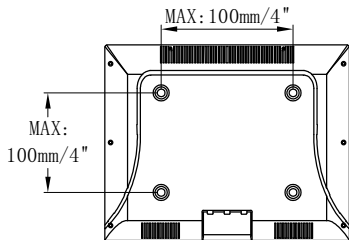

Yes --- Perfect!
No --- This mount is **NOT** compatible.

2 Does your TV (including accessories) weigh less than 33 LBS (15 kg)?



Yes --- Perfect!
No --- This mount is **NOT** compatible.

3 What is your wall made of?

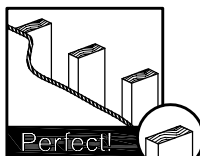

Drywall with wood studs?

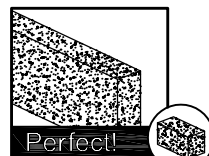

Solid concrete wall?

4 Installation Tools



Band Tape



Pencil



Screwdriver



Electrodrill



Socket Wrench 1/2"(13mm)

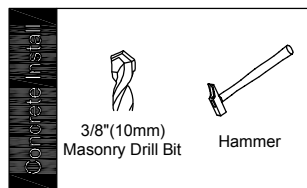
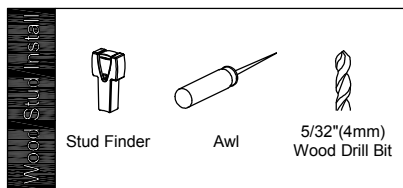

5 Safety Caution

Please read this instruction carefully before installation.
 If you do not understand these instructions or have doubts about the safety of the installation, assembly or use of this product, contact Customer Service via customerservice@mountingdream.com or call us at telephone (626) 604-9048 (USA) Mon - Fri 10am - 6pm (Pacific time).

- This product is designed for use in wood stud and solid concrete wall.
 - DO NOT install into drywall alone.
- The wall must be capable of supporting five times the weight of the TV and mount combined.
- Incorrect installation may result in product damage or body injury. Mounting Dream shall bear no responsibility for any damage or injury resulted from incorrect installation, incorrect assembly or misuse.
- Do not apply this product to any purpose not indicated by Mounting Dream.

STEP 1 Attach TV Plate to TV

Parts and Hardware

⚠ WARNING: This product contains small items that could be a choking hazard if swallowed. Before starting assembly, verify all parts are included and undamaged. For parts shortage or damage, please contact us via customerservice@mountingdream.com.

NOTE: Not all hardware included will be used.

Wall Plate Unit

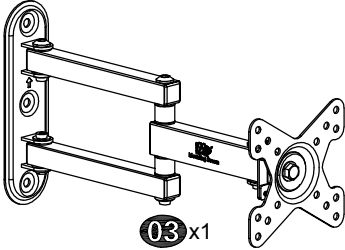

TV Screws

M4x12mm



M5x12mm



M6x12mm



Washers

M5/M4



M6



1-1 Disassemble Wall Plate Unit into Two Pieces

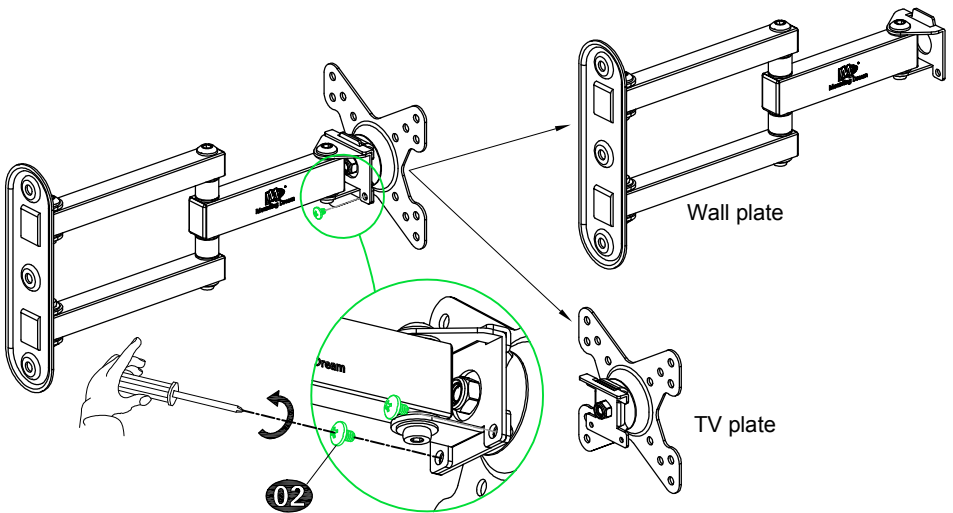

1-2 Select TV Screws

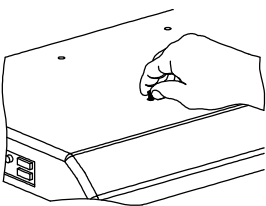

- M4
-
- M5
-
- M6
-

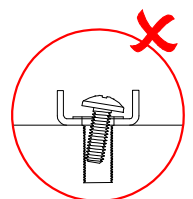
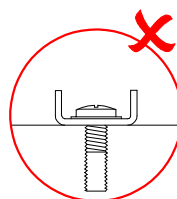
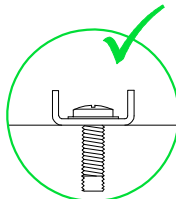

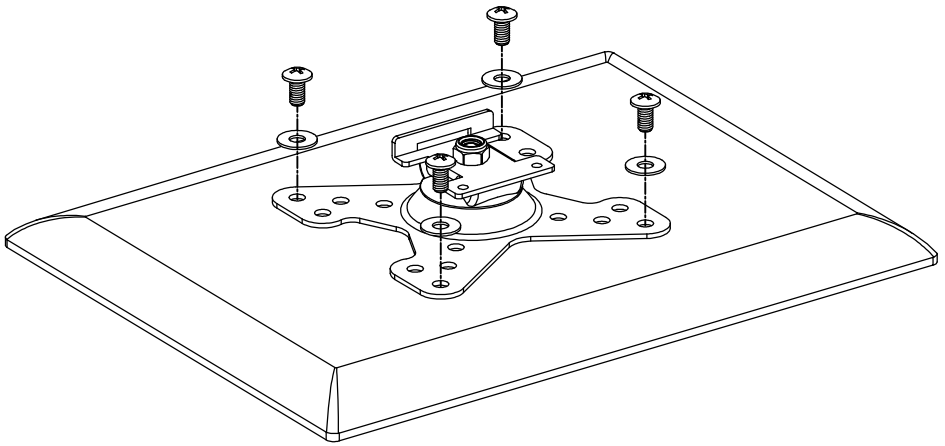
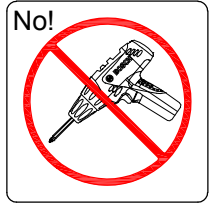
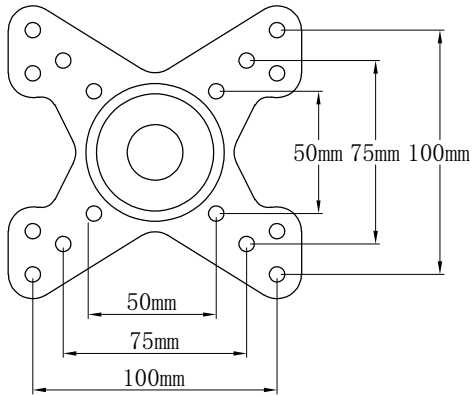

1-3 Attach TV Plate to TV Back

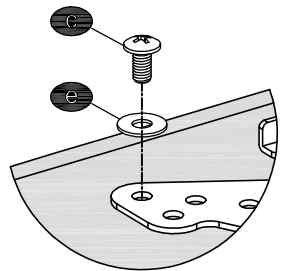
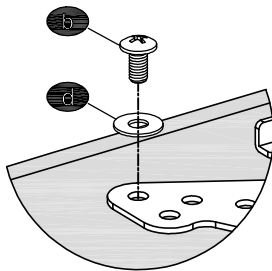
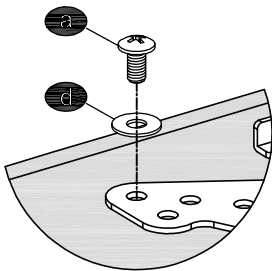

Screw and Washer Combination Options



STEP 2 Attach Wall Plate to Wall

-  For wood stud installation, follow STEP 2A
-  For concrete installation, follow STEP 2B on PAGE 6

Parts and Hardware

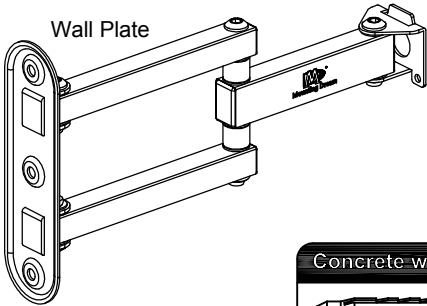

Wall Plate

8mm Open-End Wrench

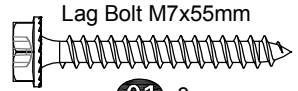
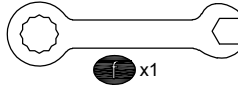

Lag Bolt M7x55mm

01 x3

Concrete wall anchor (NOT INCLUDED)



Concrete Wall Anchor
3pcs

Contact us at telephone (626) 604-9048 (USA)
Mon - Fri 10am - 6pm (Pacific time) or email us by
customerservice@mountingdream.com to have
these additional pieces shipped directly to you.

STEP 2A

Wood Stud Installation

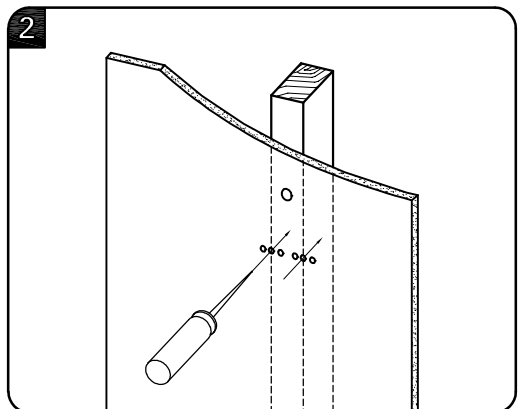
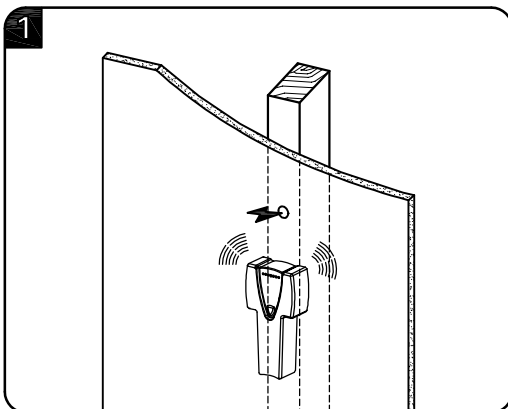
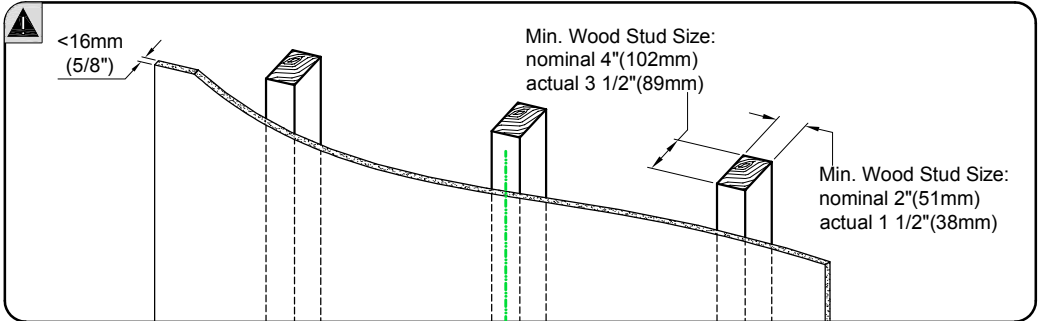

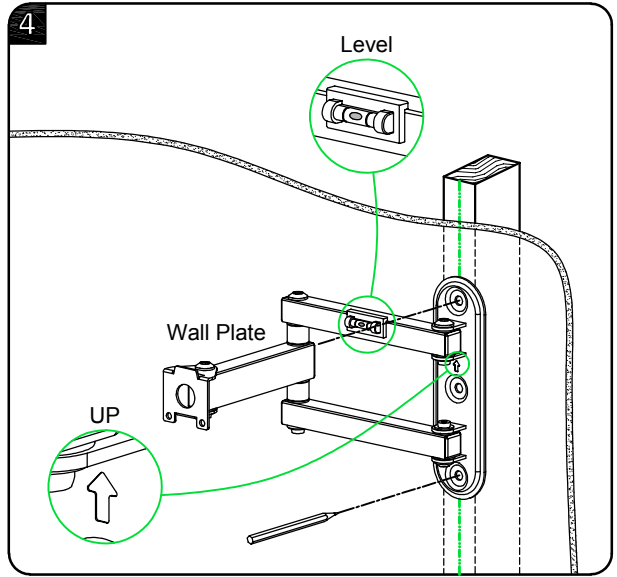
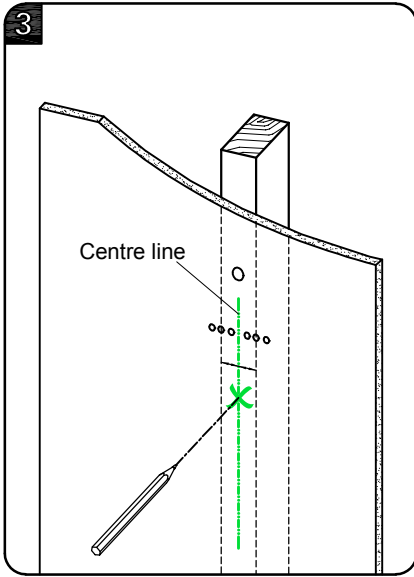

⚠ CAUTION: To avoid potential personal injury or property damage:
 All 2 lag bolts **01** MUST BE firmly tightened to prevent unwanted movement of the wall plate assembly. Ensure the wall plate assembly is securely fastened to the wall before continuing on to the next step.
 To prevent the TV falling down, the direction of the arrow should be upward as shown.

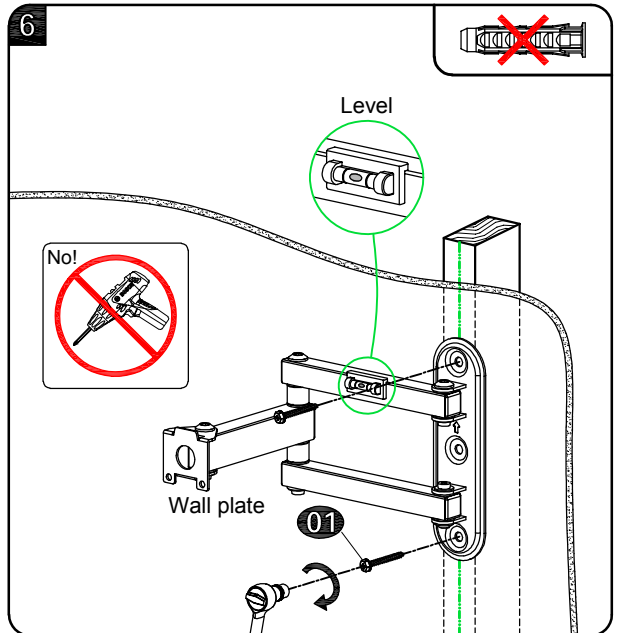
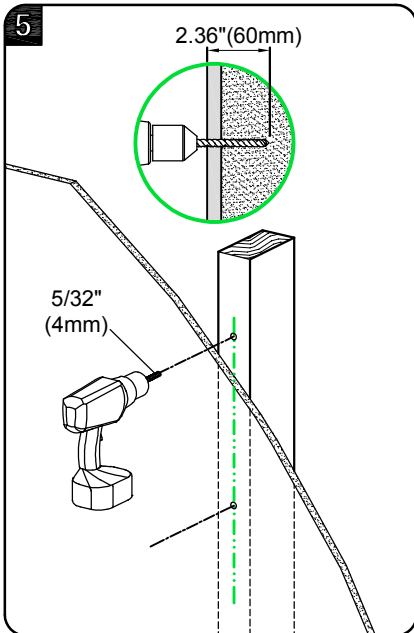

Go to Step 3 on PAGE 7

STEP 2B

Solid Concrete Wall Installation

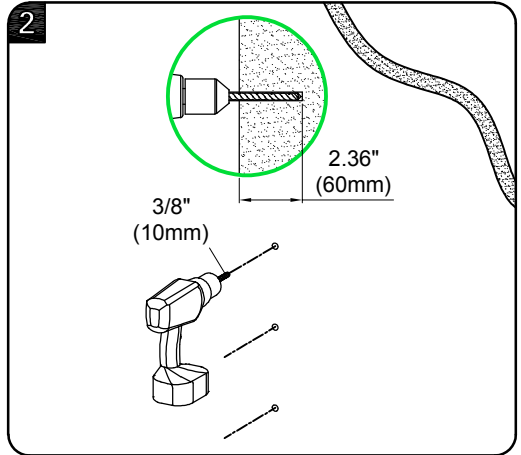
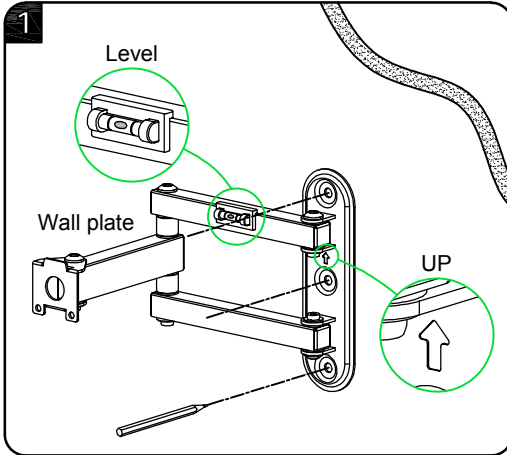
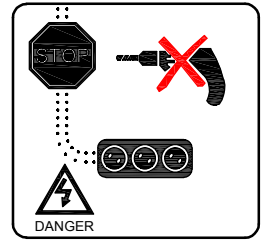
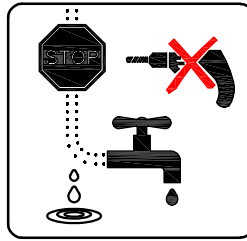
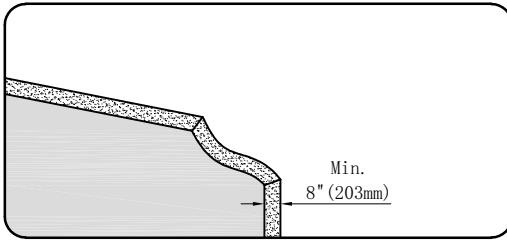

CAUTION: To avoid potential personal injury or property damage:
All 3 lag bolts **01** MUST BE firmly tightened to prevent unwanted movement of the wall plate assembly. Ensure the wall plate assembly is securely fastened to the wall before continuing on to the next step.
To prevent the TV falling down, the direction of the arrow should be upward as shown.

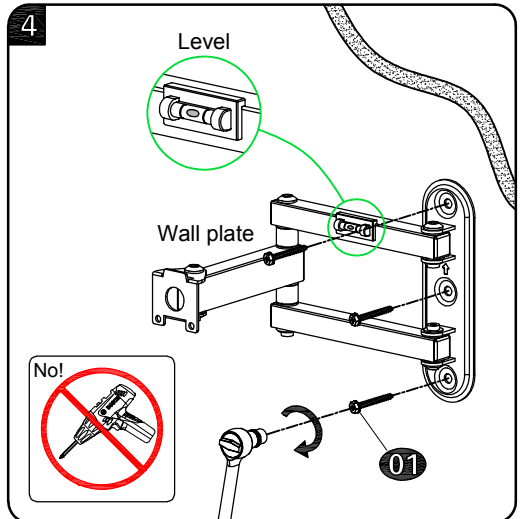
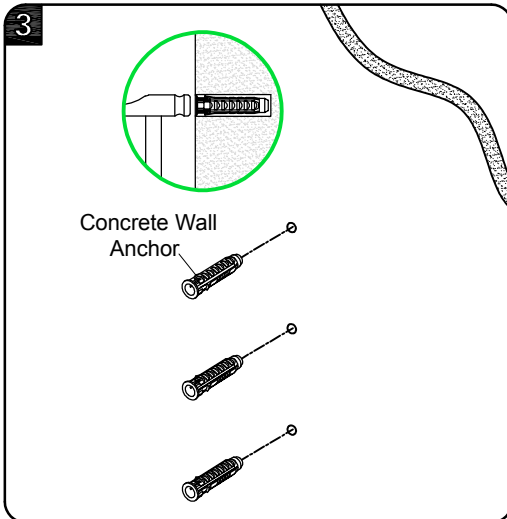

STEP 3 Hang and Secure TV to Wall Plate

Before hanging TV, please conduct "wall plate installation integrity test" first.

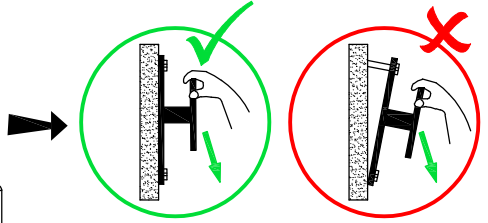
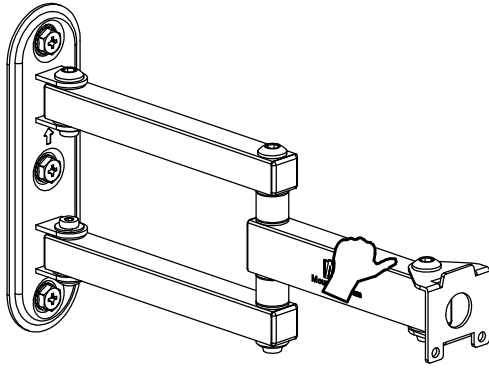

33 LBS (15 kg)

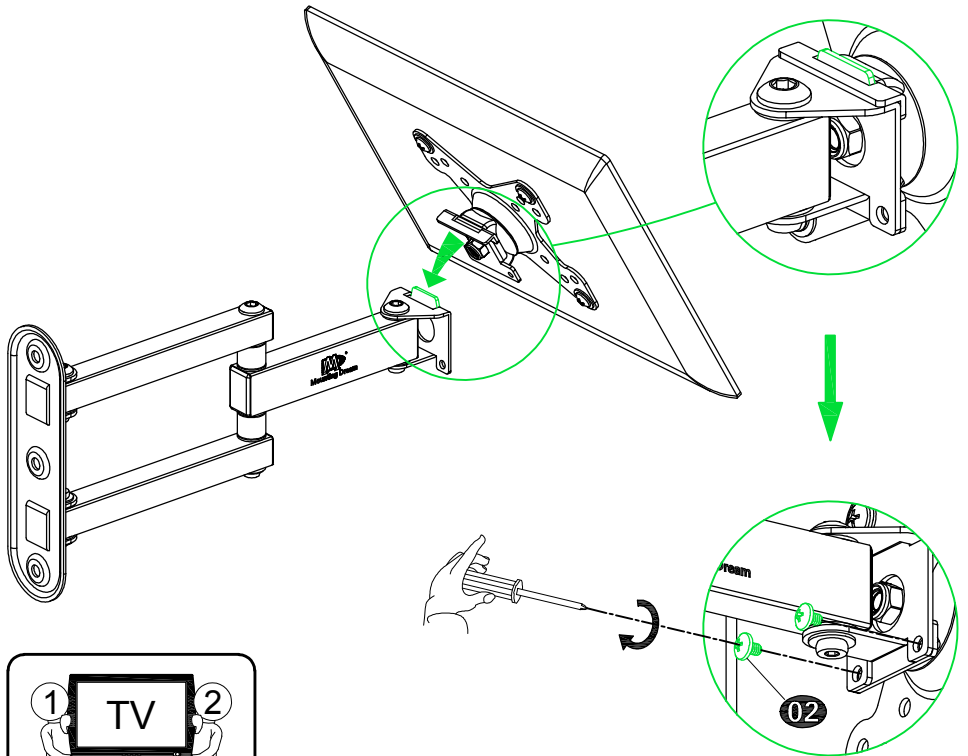

STEP 4 Adjustments

Adjust TV leveling and tilting angle by using open-end wrench  to loosen and tighten the nut.

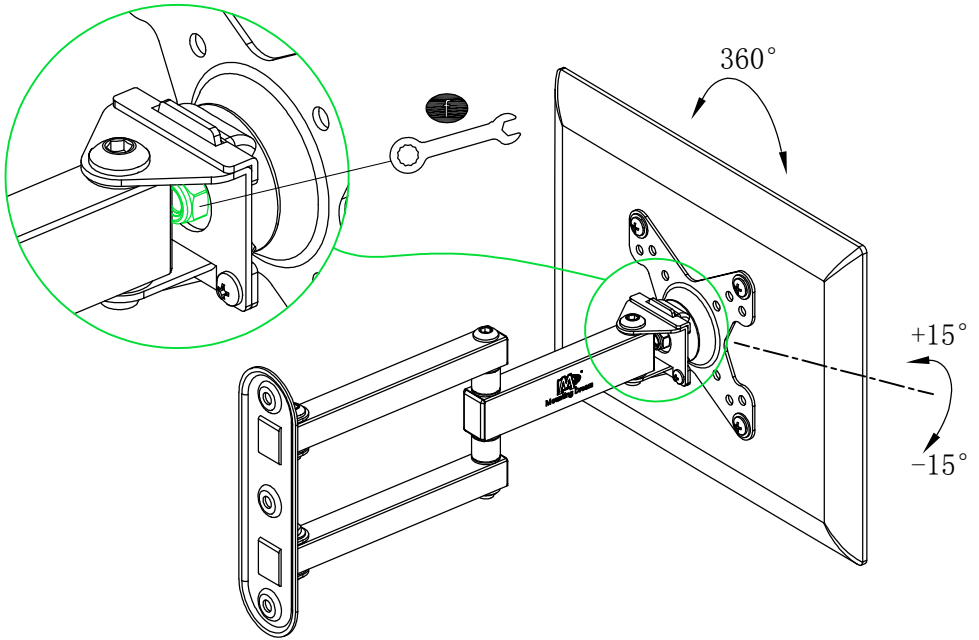

Product dimensions:

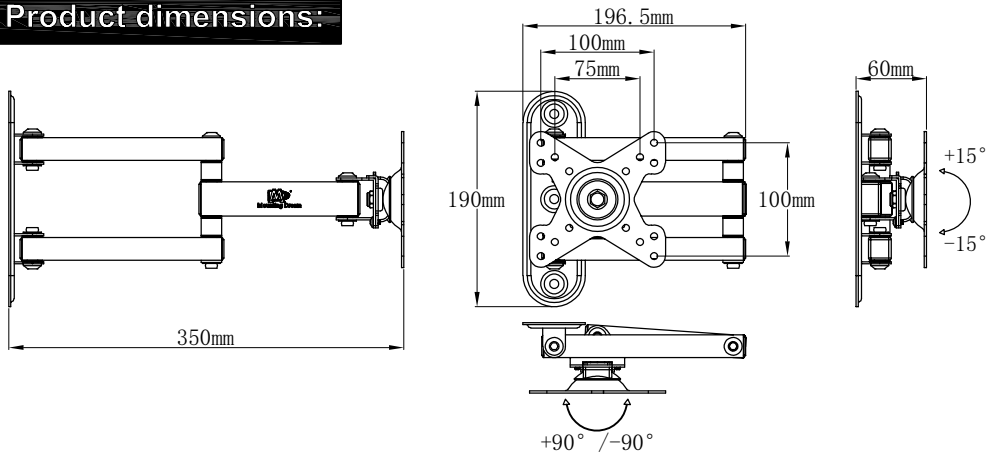

Vor der Installation bestätigen Sie bitte zuerst, ob diese Halterung für Ihr Fernsehapparat geeignet ist!

1 Ist der Abstand der Montagelöcher von Ihrem Fernsehapparat gleich 50x50mm/2x2in, 75x75mm/3x3in oder 100x100mm/4x4in?

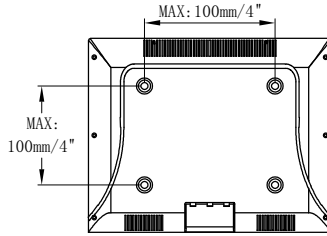

Ja - Perfekt!

Nein - Diese Halterung ist nicht geeignet!

2 Wiegt Ihr Fernsehapparat (inkl. Zubehör) weniger als 15 kg (33 LBS)?



Ja - Perfekt!

Nein - Diese Halterung ist nicht geeignet!

3 Woraus besteht Ihre Wand?

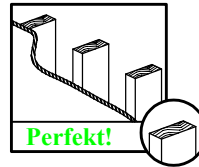

Gipskartonwand mit Holzbalken?

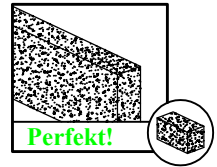

Massivbetonwand?

4 Werkzeuge für Installation

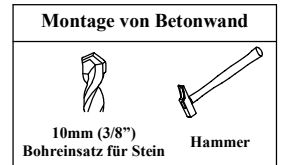
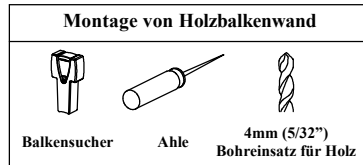

5 Sicherheitshinweise

Bitte lesen Sie die Anweisungen sorgfältig vor der Installation durch.
 Falls Sie diese Anweisungen nicht verstehen oder Zweifel bezüglich der Sicherheit der Installation, des Zusammenbaus oder der Verwendung des Produkts haben, kontaktieren Sie bitte den Kundendienst per E-Mail: customerservice@mountingdream.com. Oder rufen Sie (626) -604-9048 (USA) an. Bürozeiten: Montag bis Freitag, 10:00 - 18:00 Uhr (Pazifikzeit)

- Dieses Produkt ist für die Installation an Wänden mit Holzträgern und Massivbetonwand - NICHT an einer reinen Gipskartonwand montieren.
- Die Wand muss das Fünffache des Gesamtgewichts des Fernsehapparats und der Halterung tragen können.
- Unsachgemäße Montage dieses Produkts kann zu Verletzungen und zu den Beschädigungen an Ihrem Gerät führen. Mounting Dream haftet nicht für Schäden oder Verletzungen, die durch unsachgemäße Montage, unsachgemäßen Zusammenbau oder unsachgemäße Verwendung verursacht wurden.
- Verwenden Sie dieses Produkt nicht für einen anderen Zweck als speziell von Mounting Dream angegeben.

Installationsanweisungen



⚠️ Warnung: Dieses Produkt enthält kleine Teile, die beim Verschlucken zur Erstickungsgefahr führen können. Bevor Sie mit der Installation beginnen, überprüfen Sie bitte, ob alle Zubehörteile und Ersatzteile vollständig und unbeschädigt sind. Falls Teile fehlen oder beschädigt sind, wenden Sie sich bitte an den Kundendienst per E-Mail: customerservice@mountingdream.com.

Hinweis: Es wird nicht das gesamte mitgelieferte Befestigungsmaterial verwendet.

Schritt 1 Befestigen Sie die TV-Platte am Fernseher Siehe Seite 2

Mitgelieferte Teile und Befestigungsmaterialien

1-1 Demontieren Sie die Wandplatte in zwei Teilen

1-2 Wählen Sie Schrauben für den Fernseher aus

1-3 Befestigen Sie die TV-Platte an der Rückseite des Fernsehers

Kombinationswahl von Schraube und Unterlegscheibe

Schritt 2 Befestigen Sie die Wandplatte an der Wand

Mitgelieferte Teile und Befestigungsmaterialien

Schritt 2A Die Montage von Holzbalkenwand Siehe Seite 4

⚠️ Vorsicht: Verwenden Sie keinen Dübel, wenn Sie eine Wandplatte an einer Holzbalkenwand installieren!

⚠️ Vorsicht: Alle zwei Sechskant-Holzschrauben  müssen festgezogen werden, um ein ungewolltes Verrutschen der Wandplatte zu verhindern. Achten Sie darauf, dass die Wandplatte sicher an der Wand befestigt ist, bevor Sie mit dem nächsten Schritt anfangen. Fahren Sie bitte nach diesem Schritt mit 3. Schritt auf der Seite 7 fort. Um das Herunterfallen des Fernsehers zu verhindern, muss der Schraubenkopf in diesem Schritt nach oben zeigen!!

Schritt 2B Die Montage von Massivbetonwand Siehe Seite 6

⚠️ Vorsicht: Alle drei Sechskant-Holzschrauben  müssen festgezogen werden, um ein ungewolltes Verrutschen der Wandplatte zu verhindern. Achten Sie darauf, dass die Wandplatte sicher an der Wand befestigt ist, bevor Sie mit dem nächsten Schritt anfangen. Um das Herunterfallen des Fernsehers zu verhindern, muss der Schraubenkopf in diesem Schritt nach oben zeigen!!

Schritt 3 Hängen und befestigen Sie den Fernseher an der Wandplatte Siehe Seite 7

Bevor Sie den Fernseher an die Wandplatte hängen, führen Sie bitte eine Sicherheitsprüfung für die Montage der Wandplatte aus.

⚠️ Vorsicht: Nachdem der Fernseher sicher an der Wandplatte aufgehängt wurde, ziehen Sie mit Schraubendreher die Sicherheitsschrauben  an, um sicherzustellen, dass keine Lockerheit auftritt.

* Aus Sicherheitsgründen wird dieser Schritt am besten von zwei Personen gemeinsam ausgeführt.

Schritt 4 Funktionseinstellung Siehe Seite 8

Lösen Sie mit einem Ringmaul-Ratschenschlüssel  die Mutter hinter der TV-Platte und stellen Sie den Nivellierungs- und Neigungswinkel ein. Ziehen Sie dann die Mutter fest.

Produktabmessung Siehe Seite 8

Avant l'installation, veuillez assurer que ce support est adapté à votre téléviseur ou pas !

1 Est-ce que la distance entre des trous de montage de votre téléviseur est égale à 50x50mm/2x2in, 75x75mm/3x3in, 100x100mm/4x4in ?

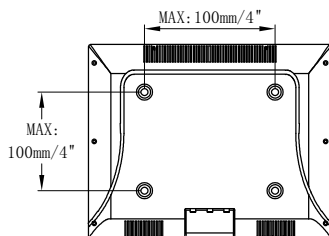

Oui - Parfait !

Non - Ce support ne vous convient pas !

2 Est-ce que votre téléviseur et des autres accessoires pèsent totalement moins de 15 kg (33 LBS)?



Oui - Parfait !

Non - Ce support ne vous convient pas !

3 De quels genres matériaux le mur est fait ?

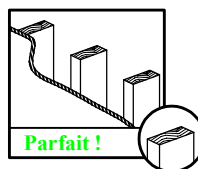
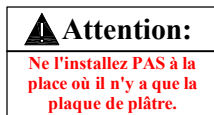

Cloison sèche avec montant en bois ?

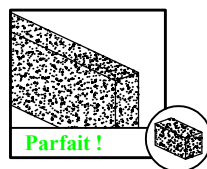

Mur en béton plein ?

4 Outils d'installation

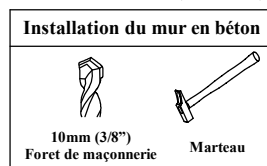
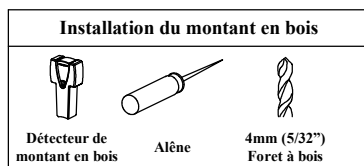

5 Consignes de sécurité

Avant l'installation, veuillez attentivement lire ce mode d'emploi. Si vous ne pouvez pas comprendre ces instructions, ou si vous avez des questions sur la sécurité de l'installation, de l'assemblage et de l'utilisation, contactez S.V.P. le service client par email: customerservice@mountingdream.com. Ou appelez-nous au (626) -604-9048 (USA). Temps de travail: du lundi au vendredi de 10h à 18h (Heure du Pacifique)

- Ce produit s'applique au montant en bois, au mur en béton plein - Ne l'installez pas à la place où il n'y a que la plaque de plâtre.
- La force portante du mur doit atteindre au moins cinq fois du poids total de votre téléviseur et du support.
- L'installation incorrecte causera le dommage matériel ou la blessure corporelle. Mounting Dream n'assumera aucune responsabilité pour le dommage et la blessure causés par l'installation incorrecte ou l'utilisation inadéquate.
- N'utilisez pas ce produit pour des autres objectifs non désignés par Mounting Dream.

Instruction d'installation

⚠ AVERTISSEMENT : Ce produit contient des petites pièces, en cas d'ingestion, des risques de suffocation y arrivera. Avant l'installation, veuillez vérifier que tous les accessoires et toutes les pièces sont complets et non défectueux. S'il y a des pièces manquantes ou endommagées, contactez S.V.P. le service client par email : customerservice@mountingdream.com.

ATTENTION : Les pièces fournies ne seront pas toutes utilisées durant l'installation.

Étape 1 Installer la plaque TV sur votre téléviseur Voir à la page 2

Pièces et accessoires

1-1 Désassembler la plaque murale en deux parties

1-2 Choisir des vis de téléviseur

1-3 Installer la plaque TV à l'arrière de votre téléviseur

Combinaison de la vis et de la rondelle

Étape 2 Installer la plaque murale au mur

Pièces et accessoires

Étape 2A Installation du montant en bois Voir à la page 4

⚠ Attention : Quand vous installez la plaque murale au mur avec le poteau de bois, n'utilisez pas les chevilles!

⚠ Attention : Tous les deux boulons tire-fond ① doivent être fermement serrés pour éviter le mouvement non souhaité de la plaque murale. Veuillez vérifier que la plaque murale est fixée sur le mur avant de passer à l'étape suivante. Après avoir fini cette étape, allez directement à la page 7 et continuez l'étape 3. Pour éviter que le téléviseur ne tombe, la tête du boulon doit faire face vers le haut !!

Étape 2B Installation du mur en béton plein Voir à la page 6

⚠ Attention : Tous les trois boulons tire-fond ① doivent être fermement serrés pour éviter le mouvement non souhaité de la plaque murale. Veuillez vérifier que la plaque murale est fixée sur le mur avant de passer à l'étape suivante. Pour éviter que le téléviseur ne tombe, la tête du boulon doit faire face vers le haut !!

Étape 3 Suspendre et fixer votre téléviseur sur la plaque murale Voir à la page 7

Avant de suspendre votre téléviseur sur la plaque murale, veuillez tester la fiabilité de l'installation de la plaque murale.

⚠ Après avoir suspendu votre téléviseur sur la plaque murale, veuillez bien serrer les vis de sécurité ② au tournevis cruciforme pour assurer qu'elles sont fixes.

* Compte tenu de la sécurité, deux personnes sont nécessaires pour l'installation.

Étape 4 Ajustement de fonction Voir à la page 8

Veuillez desserrer l'écrou à la clé à cliquet combiné ③, puis ajuster le niveau et l'angle d'inclinaison, et puis serrer l'écrou pour fixer la position.

Dimensions de produit Voir à la page 8

Antes de comenzar a instalar este soporte mural para tv , favor confirme si es el adecuado para su televisor!

1 Los orificios posteriores de su televisor tienen una distancia igual 50x50mm/2x2in, 75x75mm/3x3in, 100x100mm/4x4in?

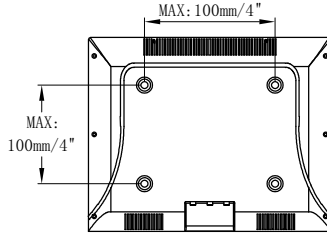

Si - Es el adecuado!

No - Este soporte no es el adecuado!

2 El peso de su televisor y los demás accesorios en total es menor a 15 kg (33 LBS)?



Si - Es el adecuado!

No - Este soporte no es el adecuado!

3 La pared de que material esta construida?

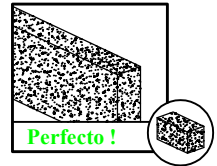
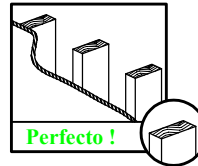

4 Herramientas necesarias para su instalación

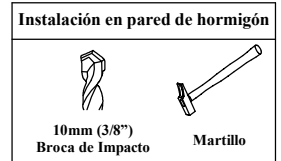
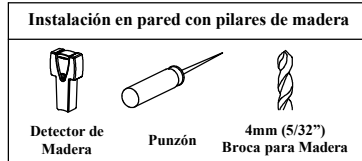

5 Advertencias de seguridad

Antes de la instalación favor de leer en detalle el manual de instrucciones. Si no comprende el manual de instrucciones, la instalación segura del producto, o si en el montaje y/o la utilización tiene alguna duda, favor de contactarse vía mail a nuestro servicio al cliente: customerservice@mountingdream.com. O llámenos al (626) -604-9048 (USA). Horario de oficina: de lunes a viernes, de 10 a.m. a 6 p.m. (Hora del Pacífico)

- Este producto es apto para paredes con pilares de madera, y muro de hormigón sólido - No instalar en paredes de solo yeso.
- La capacidad de soporte de la pared debe ser cinco veces más que el peso total del televisor y el soporte.
- La instalación incorrecta puede producir daños al producto o lesiones al usuario. Cualquier pérdida o daño debido por la mala instalación o uso indebido, Mounting Dream no asume ninguna responsabilidad.
- Favor NO utilizar el producto de Mounting Dream para otros usos no asignados.

Instrucciones paso a paso de su instalación

⚠ Advertencia: Este producto contiene piezas pequeñas, si por error se ingiere, puede provocar peligro de asfixia. Antes de comenzar la instalación, favor compruebe que todos los accesorios y piezas de repuesto estén completas y sin daño alguno. Si faltan o están dañadas, favor de contactarse con nuestro servicio al cliente: customerservice@mountingdream.com.

Atención: No todas las piezas se utilizarán.

Paso 1 Instalar la placa de TV al televisor Ver página 2

Accesorios y piezas

1-1 La placa mural se divide en dos partes

1-2 Elegir los tornillos para el televisor

1-3 Instalar la placa de TV a la parte posterior del televisor

Opciones de combinación del tornillo y la arandela

Paso 2 Instalar la placa mural

Accesorios y piezas

Paso 2A Instalación en pared con pilares de madera Ver página 4

⚠ Atención: Al momento de instalar el panel en la pared con pilares de madera, favor no usar los tacos/tarugos para la pared de hormigón!

⚠ Atención: Los dos tornillos ① de cabeza hexagonal deben apretarse firmemente, para evitar que la placa mural en la pared se mueva. Favor de asegurarse que quede firmemente estable en la pared para poder continuar con los siguientes pasos de la instalación. Luego de terminar este paso favor continuar con el paso 3 en la página 7. Para prevenir que el televisor se caiga, durante este paso, la cabeza del tornillo debe ir hacia arriba! !

Paso 2B Instalación en pared de hormigón sólido Ver página 6

⚠ Atención: Los tres tornillos ② de cabeza hexagonal deben apretarse firmemente, para evitar que la placa mural en la pared se mueva. Favor de asegurarse que quede firmemente estable en la pared para poder continuar con los siguientes pasos de su instalación. Para prevenir que el televisor se caiga, durante este paso, la cabeza del tornillo debe ir hacia arriba! !

Paso 3 Colgar y sujetar del televisor a la placa mural Ver página 7

Antes de colgar el televisor en la placa mural, favor realizar una prueba de confiabilidad a la instalación.

⚠ Atención: Después de colgar el televisor en el soporte mural, favor use el destornillador para apretar los tornillos ② de seguridad, asegurando que no haya ningún afloje.

* Por razones de seguridad, para concluir este paso es mejor hacerlo en compañía de otra persona.

Paso 4 Funciones de regulación Ver página 8

Para ajustar el nivel y el ángulo de inclinación del televisor favor use una llave de extremo abierto ③ y afloje la tuerca, luego de regularlo vuelva a apretar la tuerca.

Dimensiones del producto Ver página 8



Prima di iniziare l'installazione, per prima cosa conferma se questo Supporto è ideale per la vostra TV!

1 Se la distanza dei fori di installazione TV è uguale a 50X50mm/2x2in, 75x75mm/3x3in, 100x100mm/4x4in?

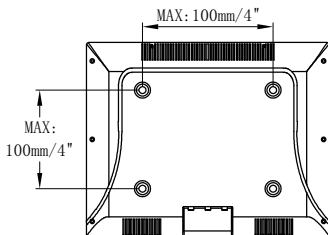

Si - Ideale!

No - Questo supporto non va!

2 Il tuo televisore (inclusi accessori) pesa totalmente inferiore a 15 kg (33 LBS)?



Si - Ideale!

No - Questo supporto non va!

3 Di che materiale è fatto il muro?

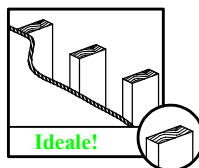

Muro secco con i pilastri in legno?

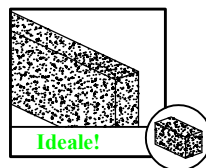

Muro in calcestruzzo solido ?

4 Utensili per installazione



Metro a nastro



Matita



Cacciavite a croce



Trapano elettrico



Chiave a tubo 13mm (1/2")



5 Cautele per sicurezza

Leggi attentamente le istruzioni prima di installazione.

Se non puoi comprendere queste istruzioni o se vi sono dubbi sull'installazione sicura, sull'assemblaggio e sull'utilizzo di questo prodotto, contatta il Servizio Clienti tramite e-mail: customerservice@mountingdream.com. Oppure chiamaci al numero (626) -604-9048 (USA). Orario d'ufficio: dal lunedì al venerdì, dalle 10:00 alle 18:00 (ora del Pacifico)

- Questo prodotto è progettato per pilastri in legno e muri in calcestruzzo solido - NON installarlo in soli cartongessi.
- Il muro deve essere capace di portare almeno cinque volte il peso totale del televisore e del supporto.
- L'installazione errata potrebbe causare danni al prodotto o lesioni personali. Mounting Dream non si assume alcuna responsabilità per danni o lesioni causate da installazione impropria o uso improprio.
- Non applicare questo prodotto ad altri scopi non indicati da Mounting Dream.



Istruzioni di installazione

⚠ Avvertenza: Questo prodotto contiene piccoli articoli che potrebbe causare il pericolo di soffocamento se ingoiati. Prima di iniziare l'installazione, controlla se tutti gli accessori e parti siano inclusi e non danneggiati. In caso di perdita o danni, contatta il Servizio Clienti via mail: customerservice@mountingdream.com.

Nota: Non verranno utilizzati tutte le parti incluse.

Passo 1 Installa la piastra TV alla TV Vedi pagina 2

Accessori e parti

1-1 Dividila piastra a muro in due parti

1-2 Seleziona viti TV

1-3 Installa la piastra TV al retro della TV

Combinazione di vite e rondella

Passo 2 Installa la piastra a muro sul muro

Accessori e parti

Passo 2A Installazione sul muro con i pilastri in legno Vedi pagina 4

⚠ Cautela: Quando si installa la piastra a muro sul muro con pilastri in legno, non utilizzare i tasselli per il muro in calcestruzzo!

⚠ Cautela: Le due viti 01 per Legno a testa esagonale devono essere avvitate bene in modo da evitare movimenti indesiderati della piastra a muro. Assicura che la piastra a muro sia ben fissata sul muro prima di eseguire il prossimo passo. Dopo finire questo passo, va direttamente alla pagina 7 per il passo 3. Per evitare che la TV cada, la testa del bullone deve essere rivolta verso l'alto!

Passo 2B Installazione sul muro in calcestruzzo Vedi pagina 6

⚠ Cautela: Le tre viti 02 per Legno a testa esagonale devono essere avvitate bene in modo da evitare movimenti indesiderati della piastra a muro. Assicura che la piastra a muro sia ben fissata sul muro prima di eseguire il prossimo passo. Per evitare che la TV cada, la testa del bullone deve essere rivolta verso l'alto!!

Passo 3 Appendi e fissa la TV alla piastra a muro Vedi pagina 7

Prima di appendere la TV alla piastra a muro, esegui un test di affidabilità dell'installazione della piastra a muro.

⚠ Cautela: Dopo appendere la TV alla piastra a muro, avvita bene le viti 02 di sicurezza con un cacciavite assicurando che non si allenti.

* Per la sicurezza, è meglio eseguire questo passo da due persone.

Passo 4 Regolazioni di funzione Vedi pagina 8

Allenta il dado dietro la piastra con la Chiavi Combinate 03, regolando contemporaneamente gli angoli di inclinazione e di livello, quindi stringi il dado per fissare la posizione.

Dimensioni del prodotto Vedi pagina 8