

Mounting Dream

MD2298 INSTALLATION INSTRUCTION

Für die Installationsanweisungen auf deutsch, Siehe Seite 11~12.

Pour l'instruction en français, veuillez vous reporter à la page 13~14.

Para las instrucciones de la instalación en español, favor vea la página 15~16.

Per le Istruzioni in italiano, vedi pagina 17~18.

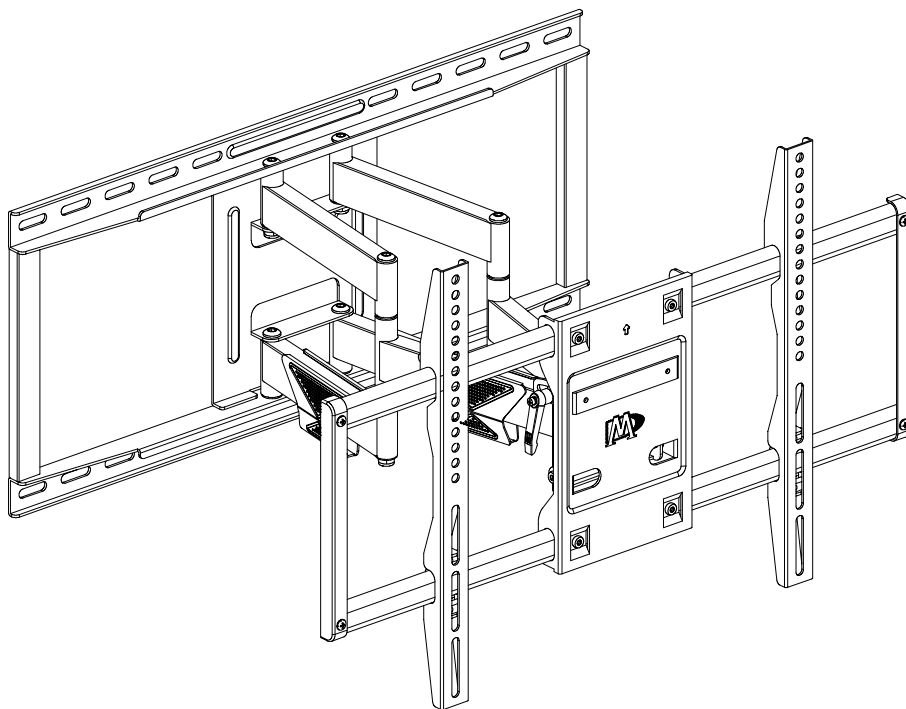

x1



x3

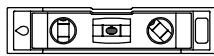

x1

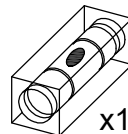

x1

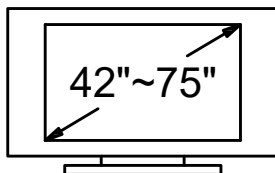

Max:600x400mm/24x16"
Min:200x200mm/8x8"

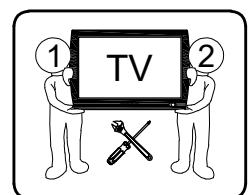

(A10)

If you have any questions, please contact us via customerservice@mountingdream.com
or call us at telephone (626) 604-9048 (USA) Mon - Fri 10am - 6pm (Pacific Time).
For more information, please visit our website: www.mountingdreamonline.com

Before getting started, let's make sure this mount is perfect for you!

1 Is your TV VESA equal to/greater than 200x200mm/8x8" and equal to/less than 600x400mm/24x16"?

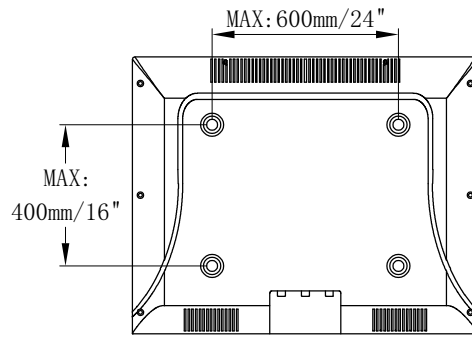

Yes --- Perfect!

No --- This mount is **NOT** compatible.

2 Does your TV (including accessories) weigh less than 132 LBS (60 kg)?



Yes --- Perfect!

No --- This mount is **NOT** compatible.

3 What is your wall made of?

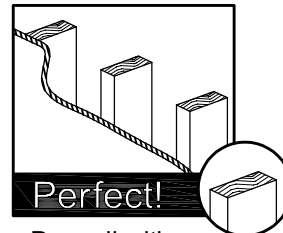

Drywall with wood studs?

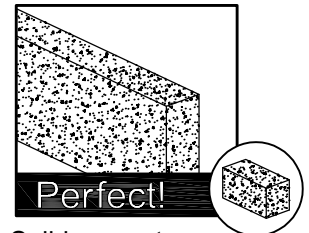

Solid concrete wall?

4 Installation Tools (Not Included)

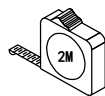

Band Tape



Pencil



Screwdriver

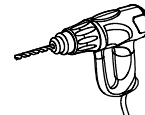

Electrodrill



Socket Wrench 1/2"(13mm)

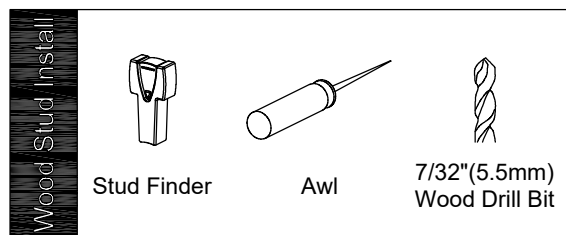

Stud Finder

Awl

7/32"(5.5mm) Wood Drill Bit

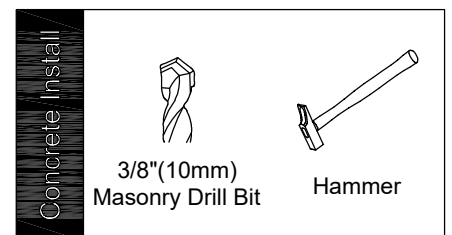

3/8"(10mm) Masonry Drill Bit

Hammer

5 Safety Caution

Please read this instruction carefully before installation. If you do not understand these instructions or have doubts about the safety of the installation, assembly or use of this product, contact Customer Service via customerservice@mountingdream.com or call us at telephone (626) 604-9048 (USA) Mon - Fri 10am - 6pm (Pacific Time).

- This product is designed for use in wood stud and solid concrete wall.
 - DO NOT install into drywall alone.
- The wall must be capable of supporting five times the weight of the TV and mount combined.
- Do not apply this product to any purpose not indicated by Mounting Dream.
- Incorrect installation may result in product damage or body injury. Mounting Dream shall bear no responsibility for any damage or injury resulted from incorrect installation, incorrect assembly or misuse.

STEP 1 Attach Brackets to TV

Parts and Hardware

⚠ WARNING: This product contains small items that could be a choking hazard if swallowed. Before starting assembly, verify all parts are included and undamaged. For parts shortage or damage, please contact us via customerservice@mountingdream.com.

NOTE: Not all hardware included will be used.

TV Brackets

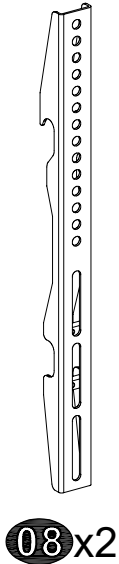

TV Screws

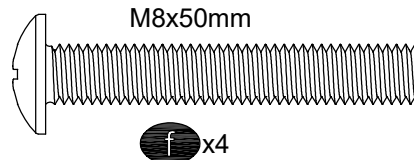
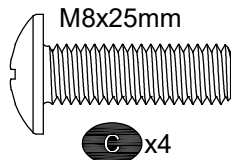
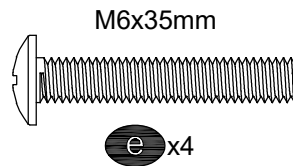
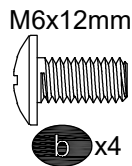
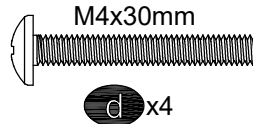
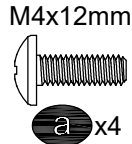

Spacers

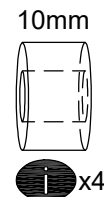
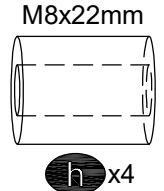
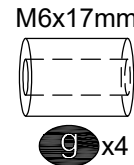

Washers

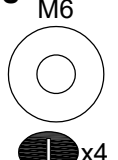
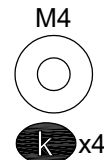

1-1 Select TV Screws

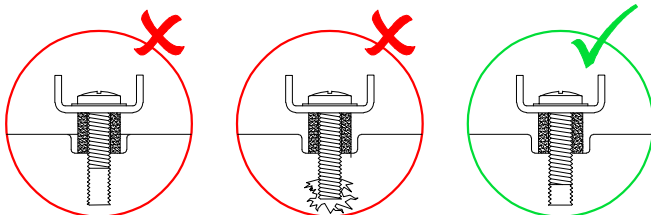
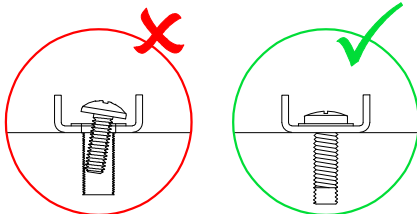
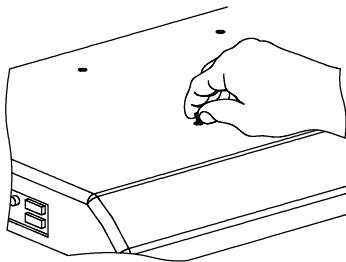

1-2 Need Spacer?

I No, go to PAGE 3 **I** for detailed combination.

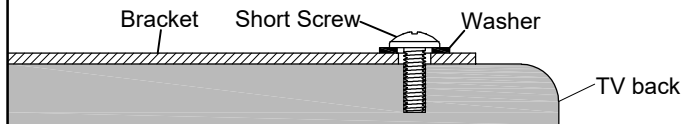

II Yes, go to PAGE 3 **II** for detailed combination.

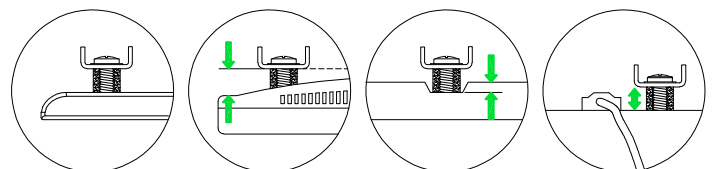
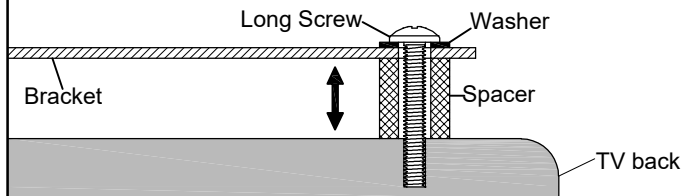

1-3 Attach the TV Brackets

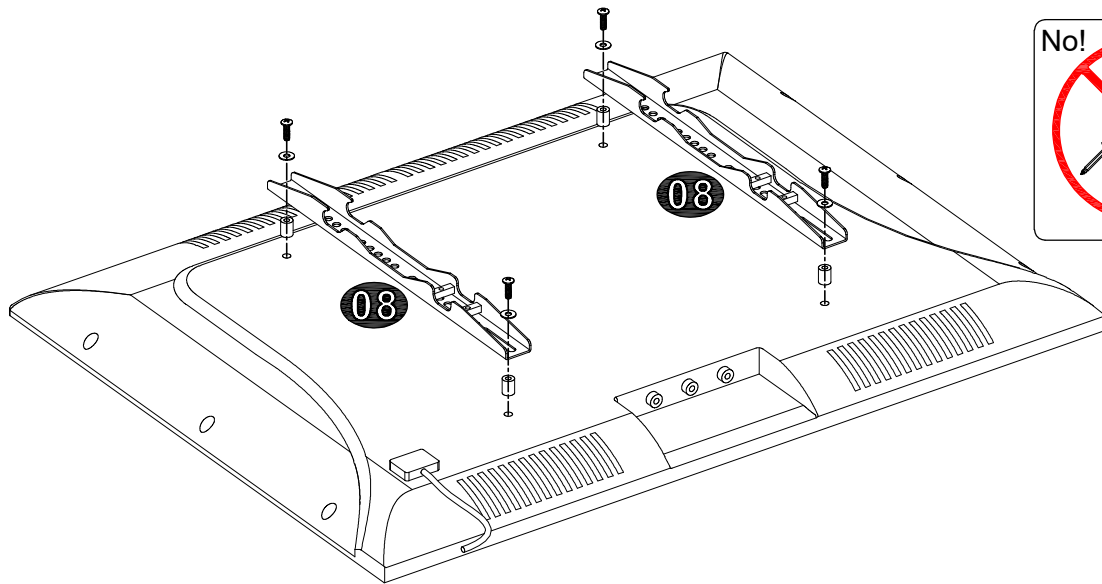

I Screw and washer

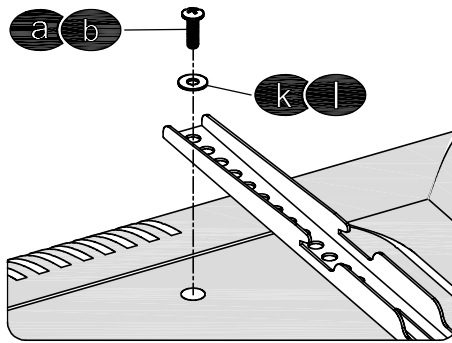

II Spacer(s), screw and washer

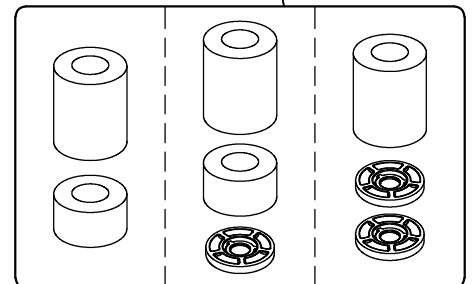
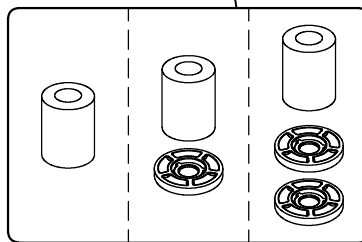
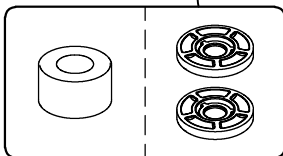
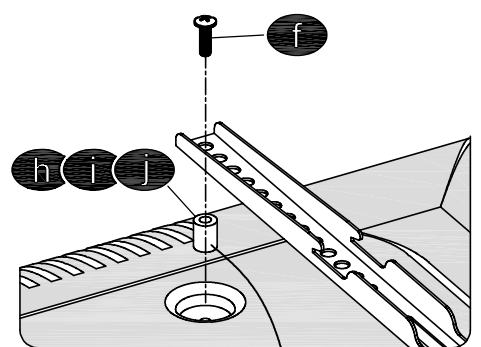
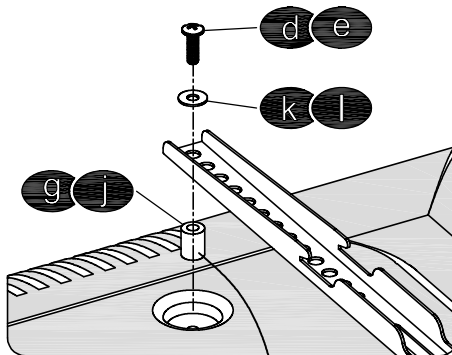
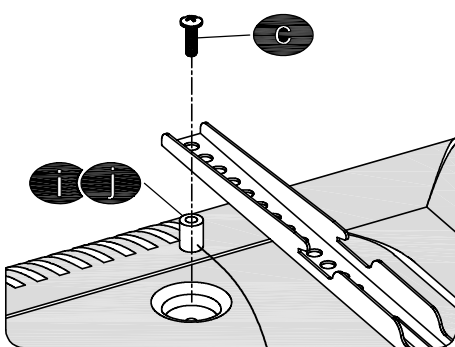

Tips: If you need to combine M6(e) or M8(c/f) screw with 2.5mm spacer(j), you have to remove the inner circle.

STEP 2 Attach Wall Plate to Wall

 For wood stud installation, follow STEP 2A

 For concrete installation, follow STEP 2B on PAGE 6

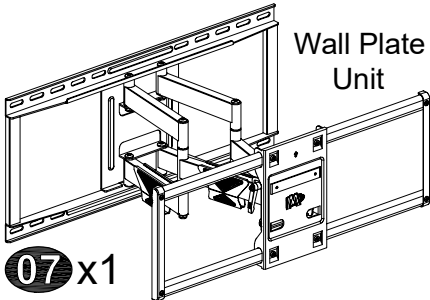

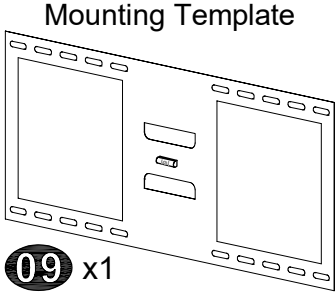

Wall Plate Unit
07 x1

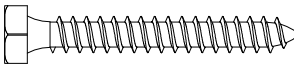

Mounting Template
09 x1

Parts and Hardware

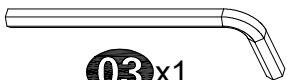
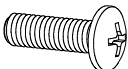
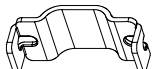
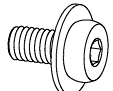
 01 x4	 02 x4	 03 x1
 04 x4	 05 x2	 06 x2

Concrete wall anchor (NOT INCLUDED)

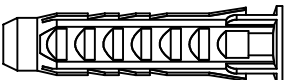

Concrete Wall Anchor
4pcs

Contact us at telephone (626) 604-9048 (USA)
Mon - Fri 10am - 6pm (Pacific Time) or email us by
customerservice@mountingdream.com to have
these additional pieces shipped directly to you.

STEP 2A Wood Stud Installation

 $<16\text{mm}$
(5/8")

24" (609.6mm)
/18" (457.2mm)
/16" (406mm)

Min. Wood Stud Size:
nominal 4" (102mm)
actual 3 1/2" (89mm)

Min. Wood Stud Size:
nominal 2" (51mm)
actual 1 1/2" (38mm)

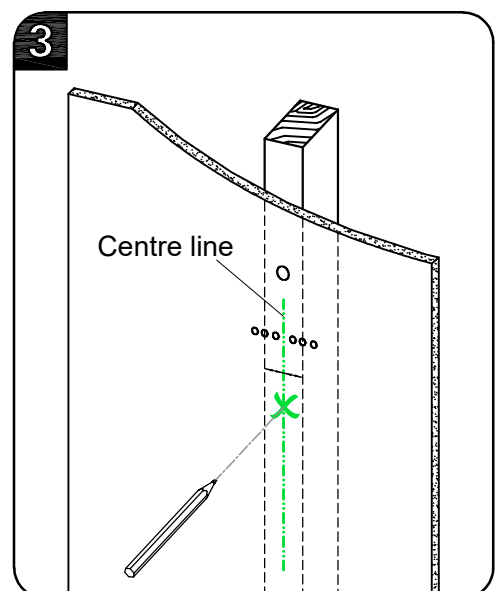
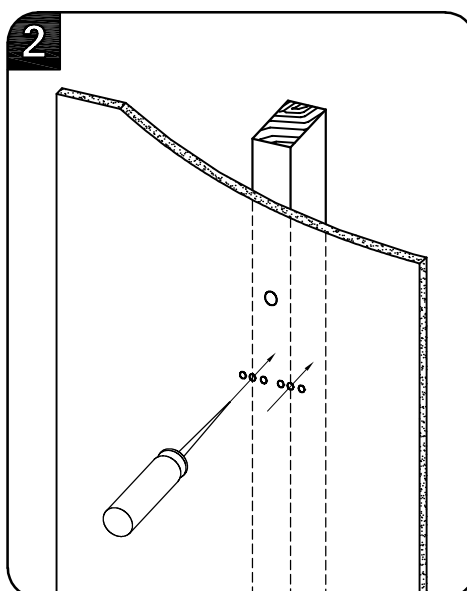
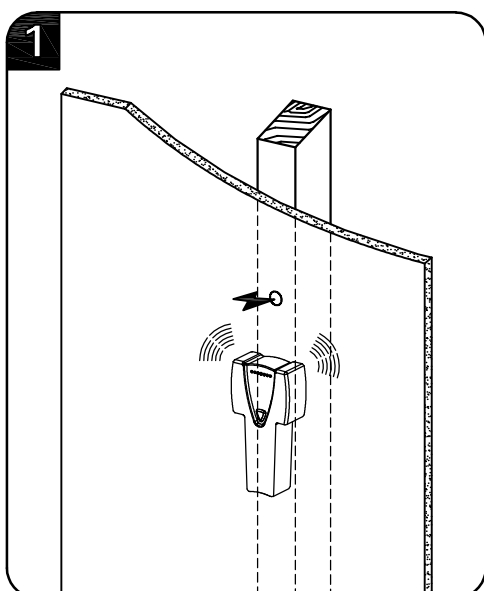

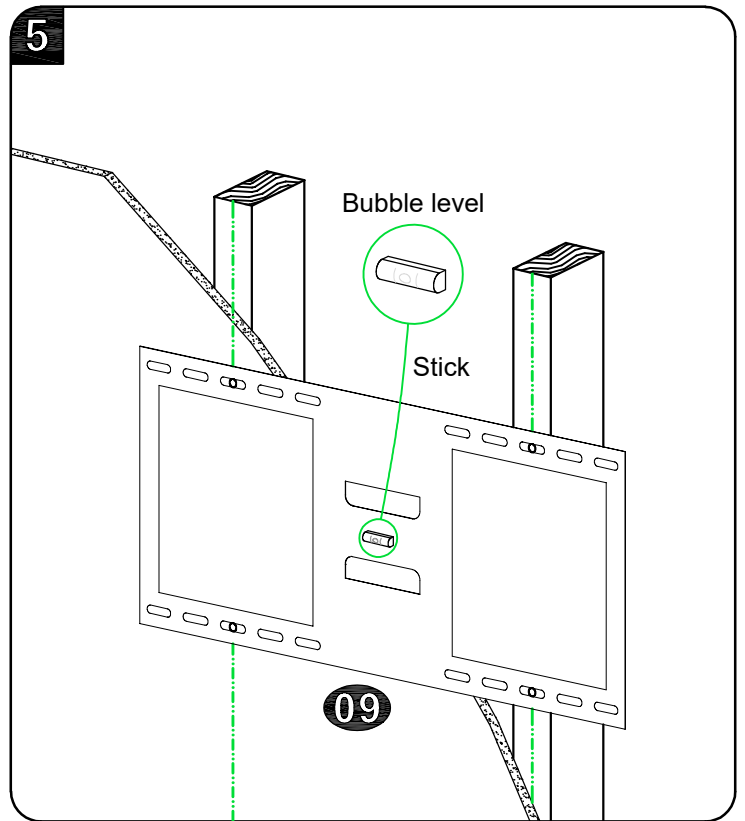
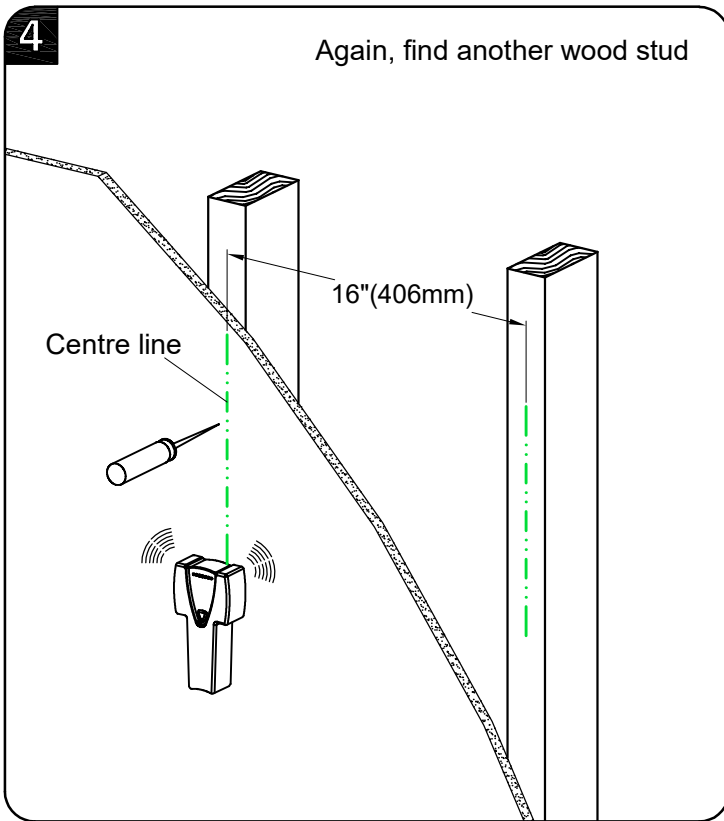

⚠ CAUTION: To avoid potential personal injury or property damage:
 All 4 lag bolts **01** MUST BE firmly tightened to prevent unwanted movement of the wall plate assembly. Ensure the wall plate assembly is securely fastened to the wall before continuing on to the next step.
 To prevent the TV falling down, the Bolt Head Must Keep UP at this step!!

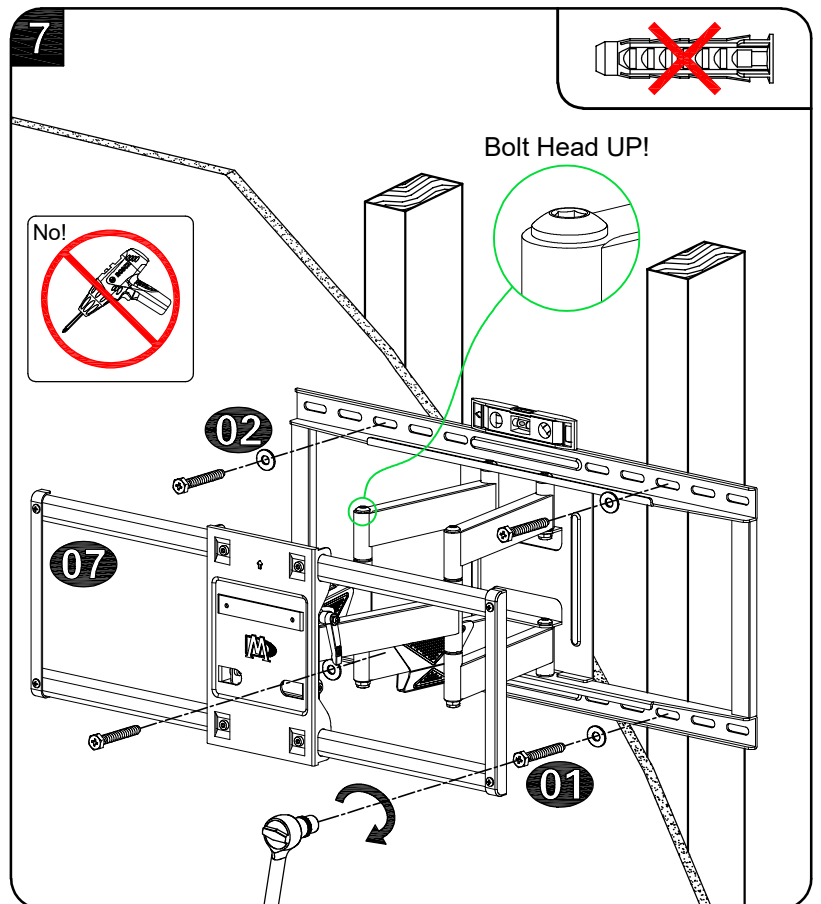
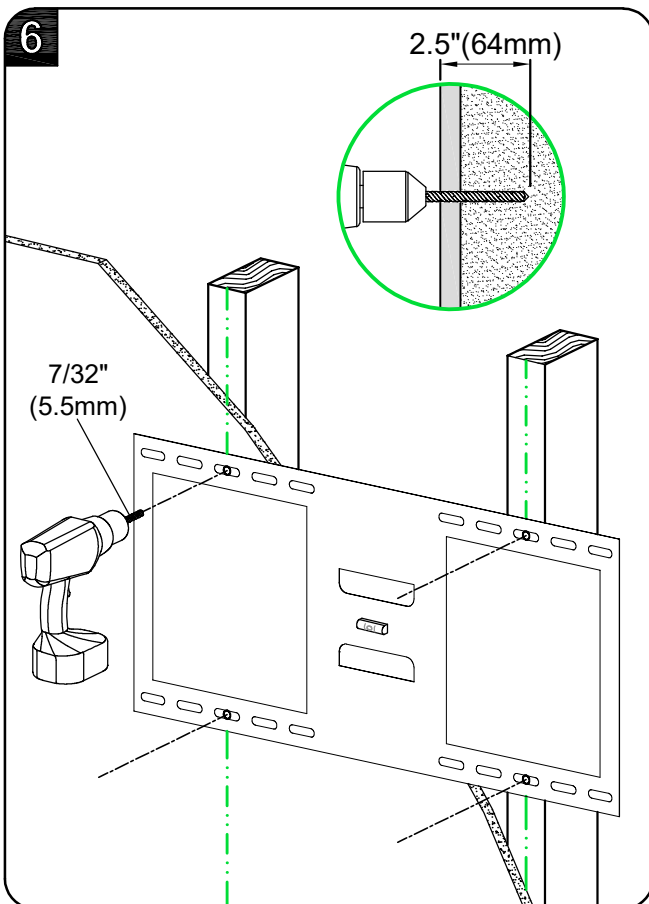

Go to Step 3 on PAGE 7.

STEP 2B

Solid Concrete Wall Installation

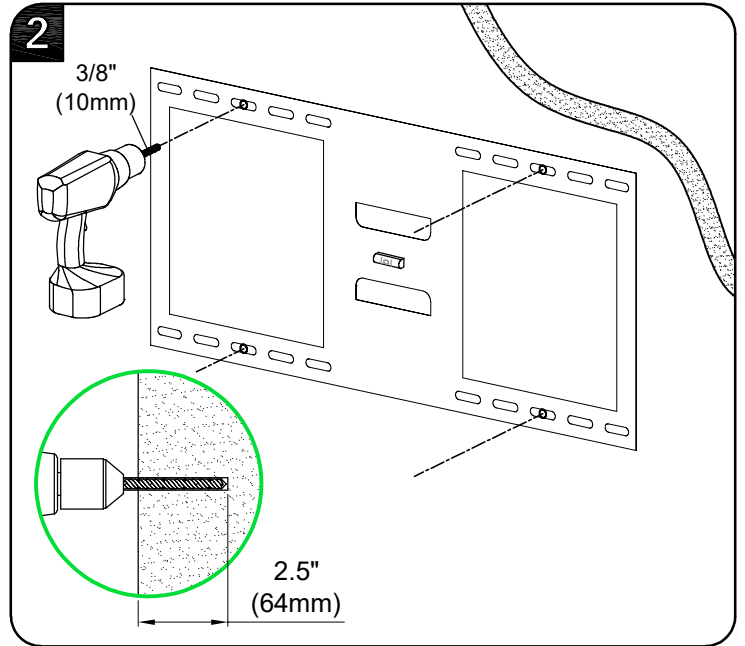
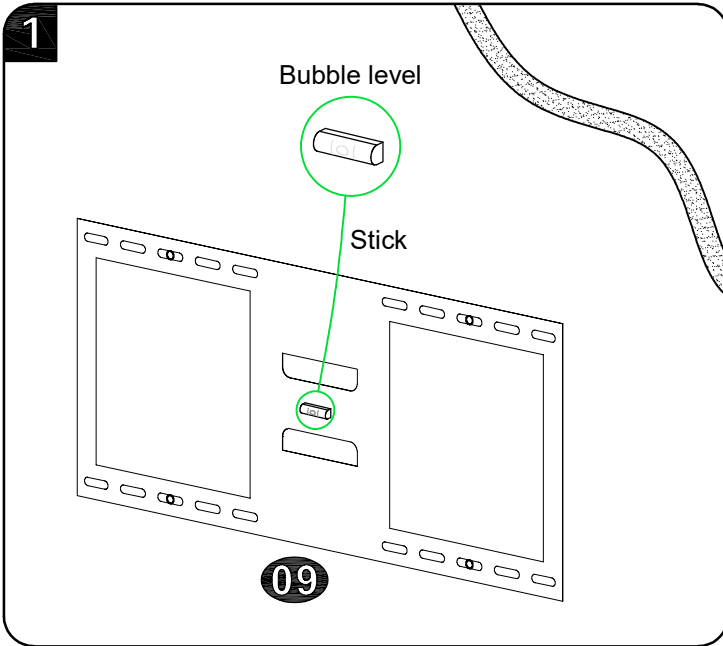
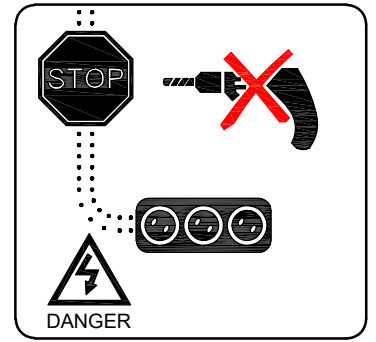
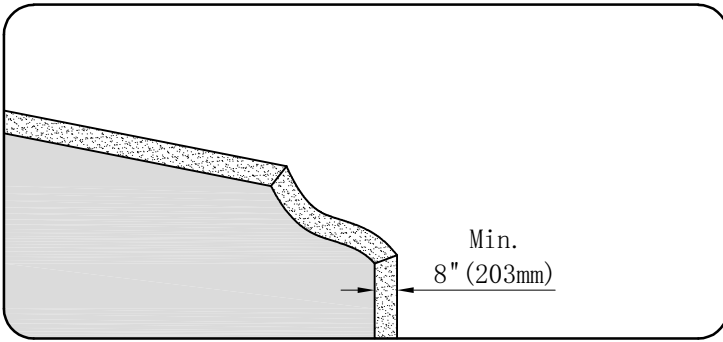

⚠ CAUTION: To avoid potential personal injury or property damage: All 4 lag bolts **01** MUST BE firmly tightened to prevent unwanted movement of the wall plate assembly. Ensure the wall plate assembly is securely fastened to the wall before continuing on to the next step.
To prevent the TV falling down, the Bolt Head Must Keep UP at this step!!

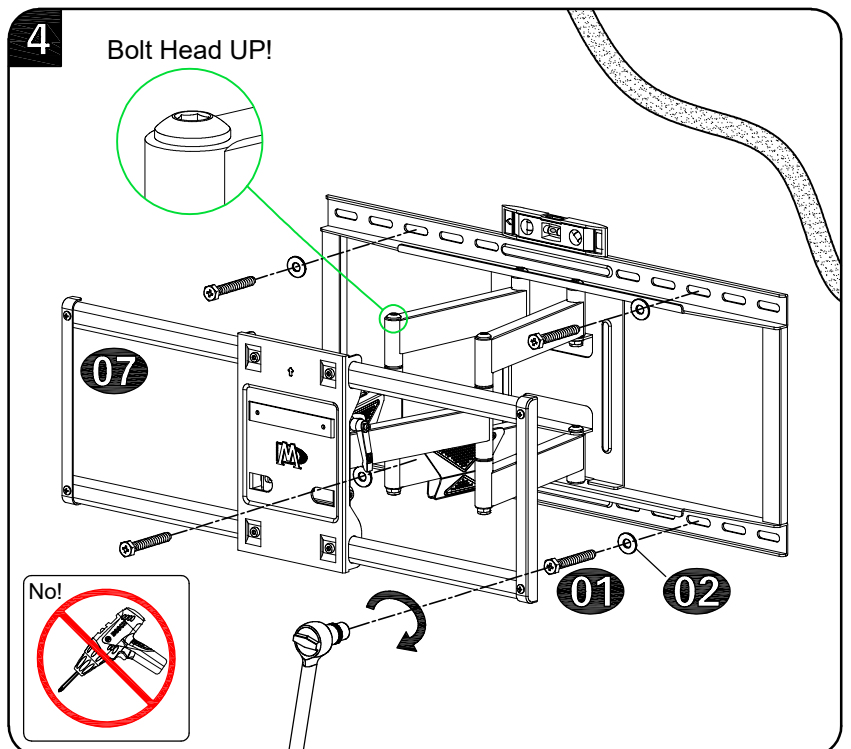
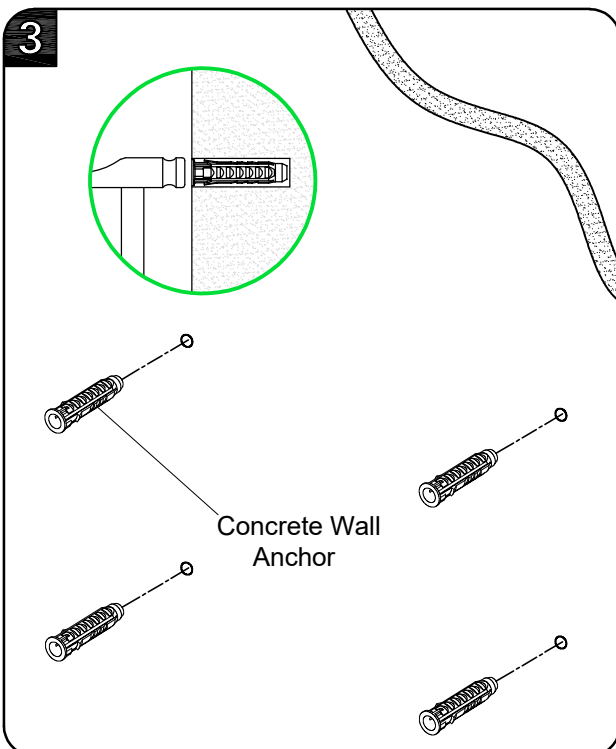

STEP 3 Hang and Secure TV to Wall Plate

Before hanging TV, please conduct "wall plate installation integrity test" first.

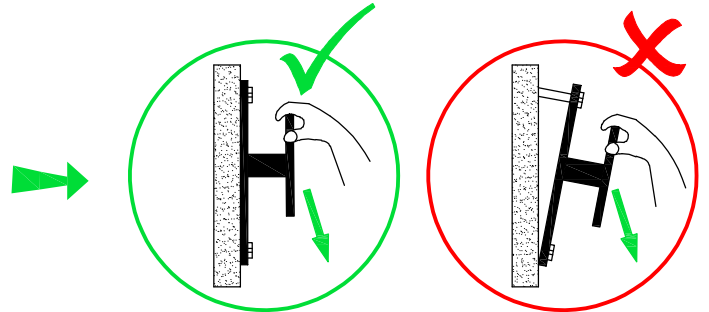
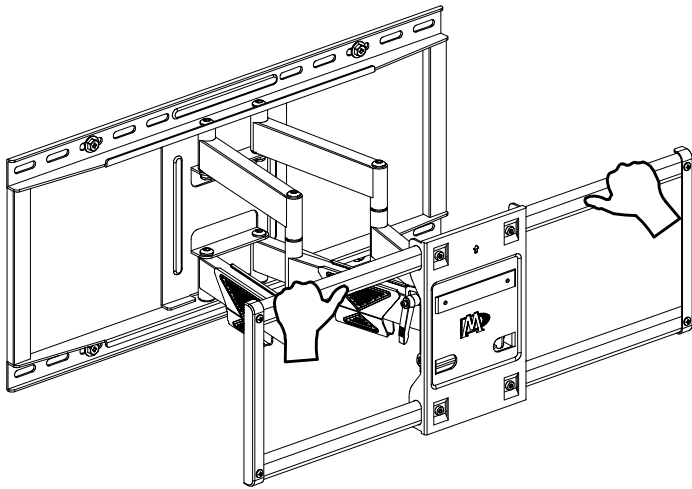

132 LBS (60 kg)

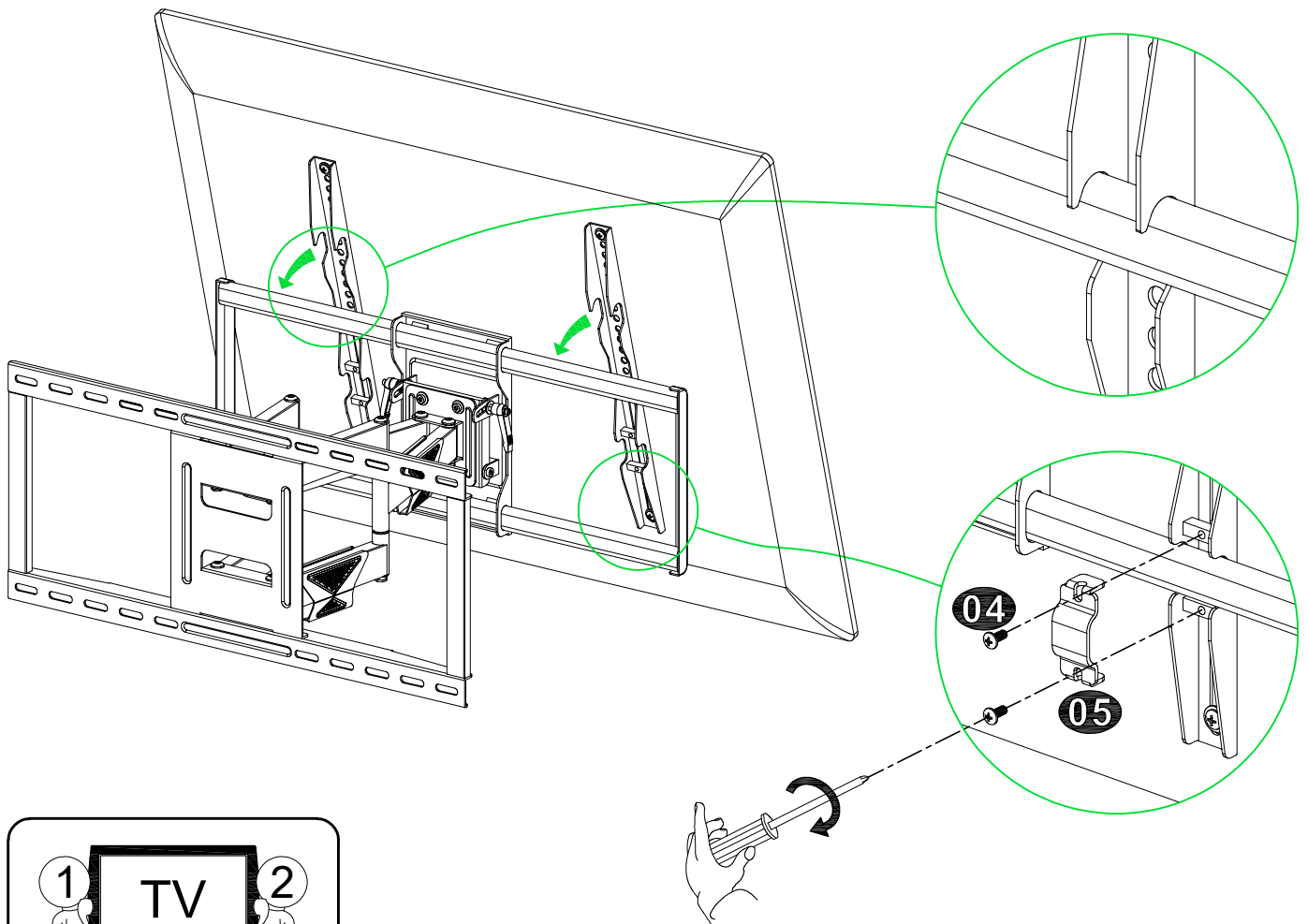

STEP 4 Adjustments

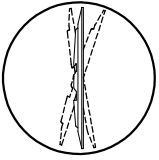

4-1 Tilting angle adjustment (+5°/-15°):
Loosen handle, adjust TV to your desired position,
then tighten handle.

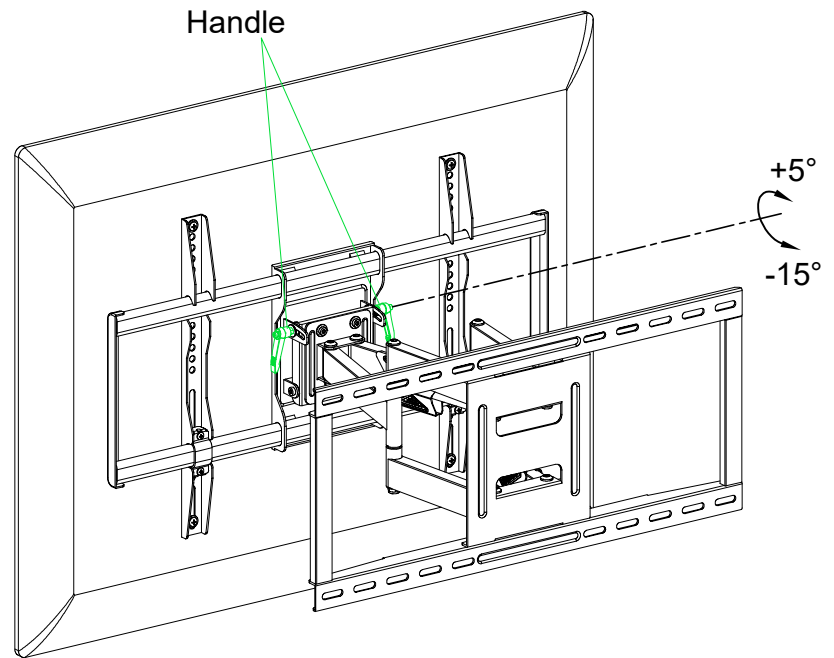

To tighten or loosen the handle

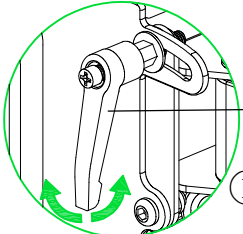

Handle

① Turn handle (loosen or tighten)
until stopped by mount.

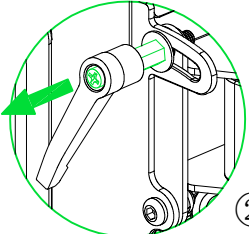

② Pull out and hold the handle.

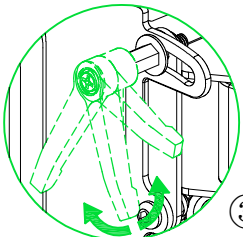

③ Turn the handle in the opposite direction.

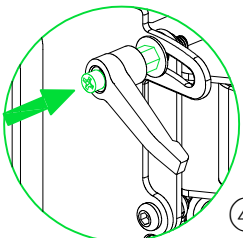

④ Push and release the handle.

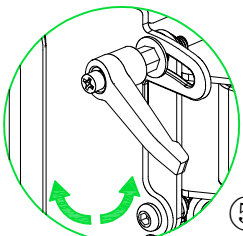

⑤ Turn handle again to tighten or loosen.

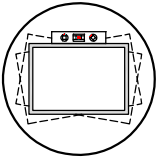

4-2 TV leveling adjustment ($\pm 3^\circ$):

Loosen 2 leveling bolts on the rear of TV plate by maximum 2 turns, adjust to level, and retighten to secure.

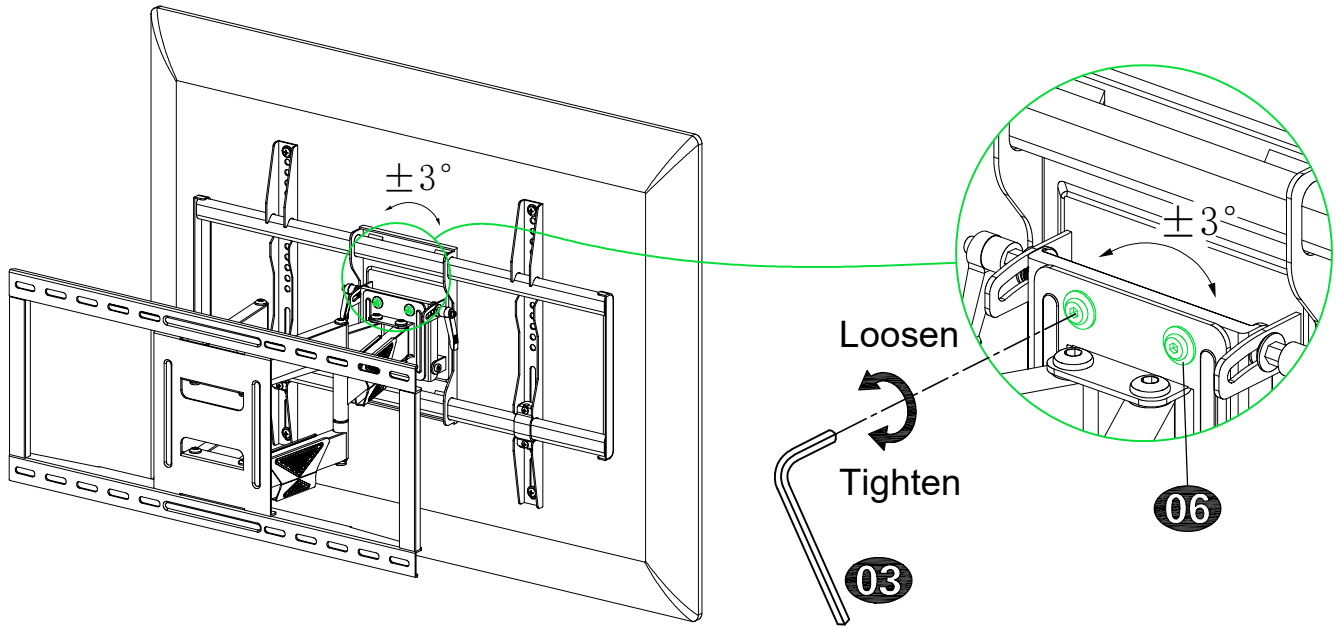

STEP 5 Cable Management

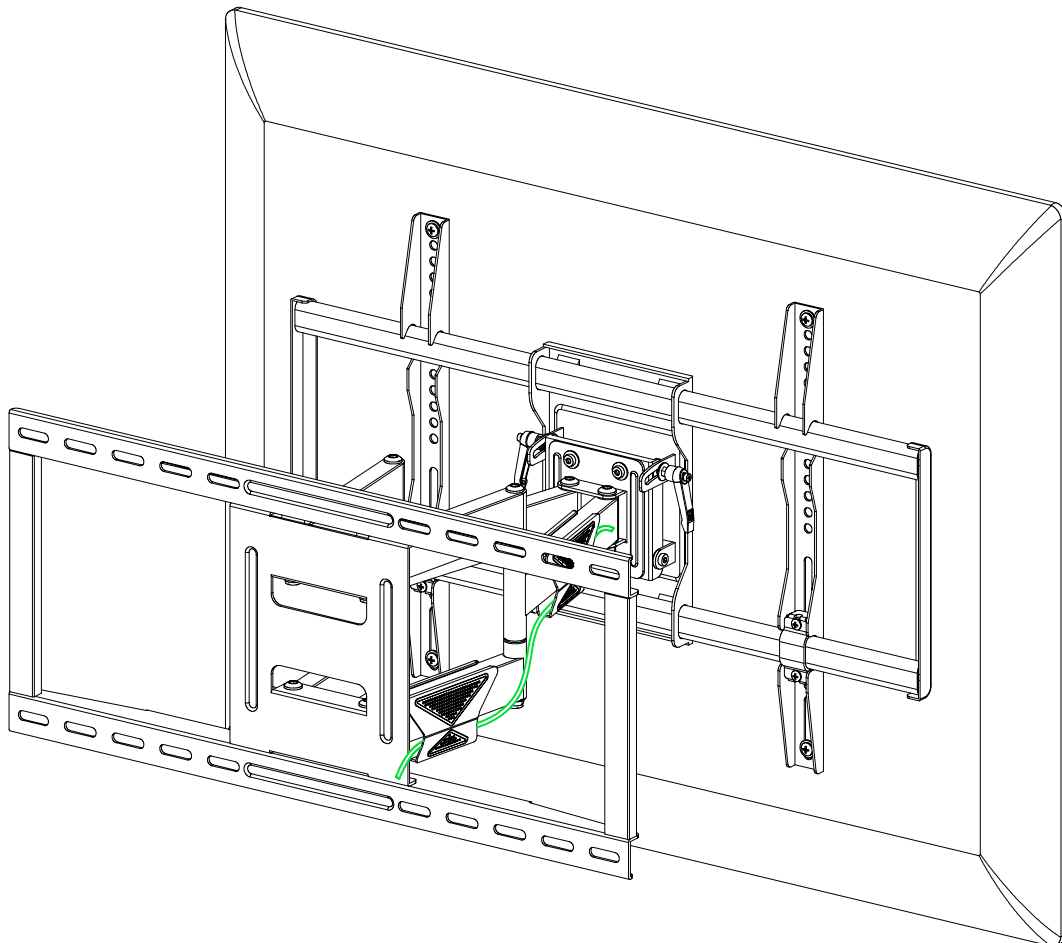

Product dimensions:

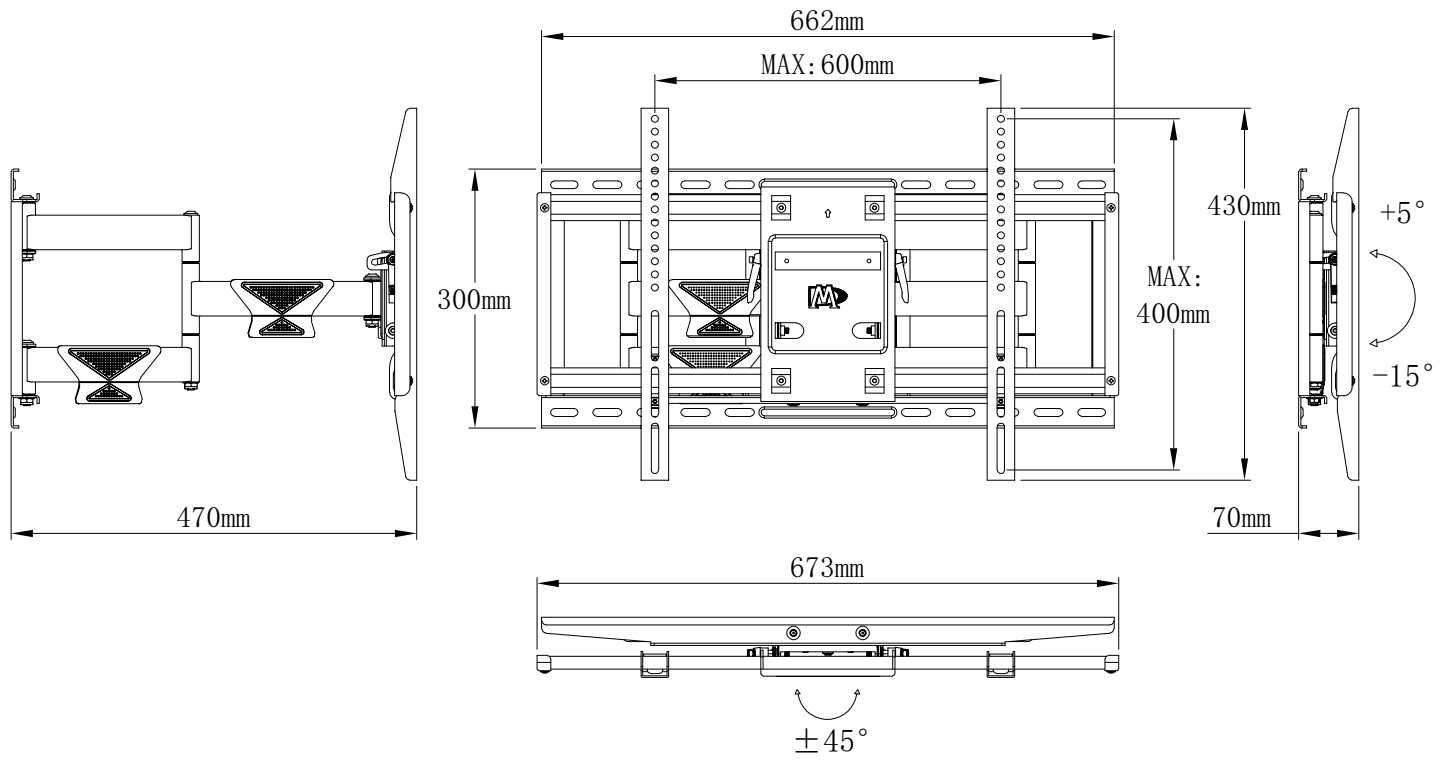

Vor der Installation bestätigen Sie bitte zuerst, ob diese Halterung für Ihr Fernsehapparat geeignet ist!

1 Ist der Abstand der Montagelöcher von Ihrem Fernsehapparat zwischen 200x100mm/8x4" und 600x400mm/24x16"?

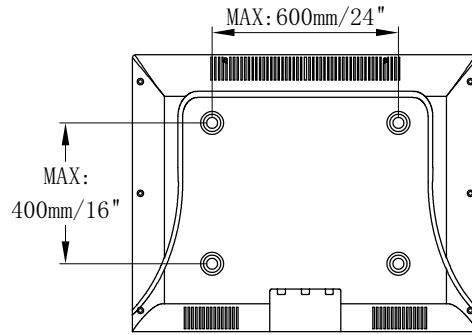

Ja - Perfekt!

Nein - Diese Halterung ist nicht geeignet!

2 Wiegt Ihr Fernsehapparat (inkl. Zubehör) weniger als 60 kg (132 LBS)?



Ja - Perfekt!

Nein - Diese Halterung ist nicht geeignet!

3 Woraus besteht Ihre Wand?

Vorsicht:
NICHT an einer reinen Gipskartonwand anbringen.

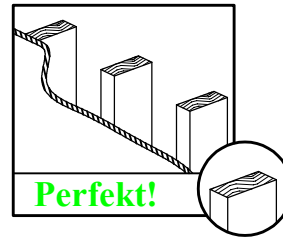

Gipskartonwand mit Holzbalken?

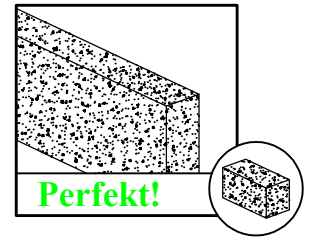

Massivbetonwand?

4 Werkzeuge für Installation (Nicht enthalten)

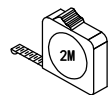

Bandmaß



Bleistift



Kreuzschlitzschraubendreher

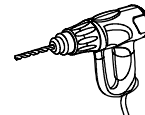

Elektrobohrer

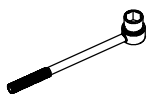

Steckschlüssel (13mm, 1/2")

Montage von Holzbalkenwand



Balkensucher

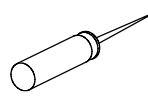

Ahle



5,5mm (7/32") Bohreinsatz für Holz

Montage von Betonwand



10mm (3/8") Bohreinsatz für Stein

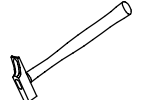

Hammer

5 Sicherheitshinweise

Bitte lesen Sie die Anweisungen sorgfältig vor der Installation durch.

Falls Sie diese Anweisungen nicht verstehen oder Zweifel bezüglich der Sicherheit der Installation, des Zusammenbaus oder der Verwendung des Produkts haben, kontaktieren Sie bitte den Kundendienst per E-Mail: customerservice@mountingdream.com. Oder rufen Sie (626) -604-9048 (USA) an. Bürozeiten: Montag bis Freitag, 10:00 - 18:00 Uhr (Pazifikzeit)

- Dieses Produkt ist für die Installation an Wänden mit Holzträgern und Massivbetonwand - NICHT an einer reinen Gipskartonwand montieren.
- Die Wand muss das Fünffache des Gesamtgewichts des Fernsehapparats und der Halterung tragen können.
- Verwenden Sie dieses Produkt nicht für einen anderen Zweck als speziell von Mounting Dream angegeben.
- Unsachgemäße Montage dieses Produkts kann zu Verletzungen und zu den Beschädigungen an Ihrem Gerät führen. Mounting Dream haftet nicht für Schäden oder Verletzungen, die durch unsachgemäße Montage, unsachgemäßen Zusammenbau oder unsachgemäße Verwendung verursacht wurden.

Installationsanweisungen

⚠ Warnung: Dieses Produkt enthält kleine Teile, die beim Verschlucken zur Erstickungsgefahr führen können. Bevor Sie mit der Installation beginnen, überprüfen Sie bitte, ob alle Zubehörteile und Ersatzteile vollständig und unbeschädigt sind. Falls Teile fehlen oder beschädigt sind, wenden Sie sich bitte an den Kundendienst per E-Mail: customerservice@mountingdream.com.

Hinweis: Es wird nicht das gesamte mitgelieferte Befestigungsmaterial verwendet.

Schritt 1 Befestigen Sie die Schienen am Fernseher Siehe Seite 2

Mitgelieferte Teile und Befestigungsmaterialien

1-1 Wählen Sie Schrauben für den Fernseher aus

1-2 Abstandhalter?

I Wenn ja, siehe Seite 3, Kombination **I**.

II Wenn nein, siehe Seite 3, Kombination **II**.

1-3 Befestigen Sie die Fernseher-Schienen

Tipps: Bei der Verwendung von M6(e) / M8(c / f) Schrauben, wenn dabei ein Abstandhalter (j) von 2,5mm gleichzeitig gebraucht wird, entfernen Sie dabei bitte den eingebauten Ring.

Schritt 2 Befestigen Sie die Wandplatte an der Wand

Mitgelieferte Teile und Befestigungsmaterialien

Schritt 2A Die Montage von Holzbalkenwand Siehe Seite 4

⚠ Vorsicht: Verwenden Sie keinen Dübel, wenn Sie eine Wandplatte an einer Holzbalkenwand installieren!

⚠ Vorsicht: Alle vier Sechskant-Holzschrauben **01** müssen festgezogen werden, um ein ungewolltes Verrutschen der Wandplatte zu verhindern. Achten Sie darauf, dass die Wandplatte sicher an der Wand befestigt ist, bevor Sie mit dem nächsten Schritt anfangen. Fahren Sie bitte nach diesem Schritt mit 3. Schritt auf der Seite 7 fort.

Um das Herunterfallen des Fernsehers zu verhindern, muss der Schraubenkopf in diesem Schritt nach oben zeigen!!

Schritt 2B Die Montage von Massivbetonwand Siehe Seite 6

⚠ Vorsicht: Alle vier Sechskant-Holzschrauben **01** müssen festgezogen werden, um ein ungewolltes Verrutschen der Wandplatte zu verhindern. Achten Sie darauf, dass die Wandplatte sicher an der Wand befestigt ist, bevor Sie mit dem nächsten Schritt anfangen.

Um das Herunterfallen des Fernsehers zu verhindern, muss der Schraubenkopf in diesem Schritt nach oben zeigen!!

Schritt 3 Hängen und befestigen Sie den Fernseher an der Wandplatte Siehe Seite 7

Eine Sicherheitsprüfung für die Montage der Wandplatte

Bevor Sie den Fernseher an die Wandplatte hängen, führen Sie bitte eine Sicherheitsprüfung für die Montage der Wandplatte aus.

Hängen und befestigen Sie den Fernseher an der Wandplatte

⚠ Vorsicht: Nachdem der Fernseher sicher an der Wandplatte aufgehängt wurde, verriegeln Sie die Sicherheitsschrauben **04** mit einem Schraubendreher, um sicherzustellen, dass keine Lockerheit auftritt.

*Aus Sicherheitsgründen wird dieser Schritt am besten von zwei Personen gemeinsam ausgeführt.

Schritt 4 Funktionseinstellung Siehe Seite 8

4-1 Neigungseinstellung (+5°/-15°)

Lösen Sie zuerst den Griff, stellen Sie dann das Fernsehgerät auf den gewünschten Winkel ein und ziehen Sie schließlich den Griff, um den Neigungswinkel zu fixieren.

Spannen oder lösen Sie den Griff:

- ① Drehen (locker oder fest) Sie den Griff, bis er nicht gedreht werden kann.
- ② Ziehen Sie den Griff heraus und halten Sie ihn.
- ③ Drehen Sie den Griff in die entgegengesetzte Richtung.
- ④ Drücken Sie den Griff und dann lassen Sie den los.
- ⑤ Drehen Sie den Griff erneut, um ihn festzuziehen oder zu lösen.

4-2 Nivellierungseinstellung (+/-3°)

Verwenden Sie einen Inbusschlüssel **03** und lösen Sie die zwei hinter der TV-Platte eingebettete Nivellierschrauben (Nicht mehr als zwei Umdrehungen) gegen den Uhrzeigersinn, stellen Sie die TV-Platte ein und ziehen Sie die Schrauben mit einem Schraubenschlüssel im Uhrzeigersinn fest.

Schritt 5 Kabelmanagement Siehe Seite 9

Produktabmessung Siehe Seite 10

Avant l'installation, veuillez assurer que ce support est adapté à votre téléviseur ou pas !

1 Est-ce que la distance entre des trous de montage de votre téléviseur est plus de ou égale à 200x100mm/8x4" et moins de ou égale à 600x400mm/24x16"?

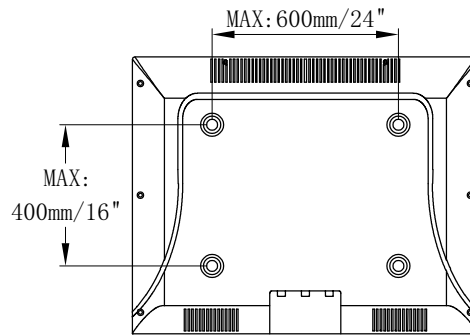

Oui - Parfait !

Non - Ce support ne vous convient pas !

2 Est-ce que votre téléviseur et des autres accessoires pèsent totalement moins de 60 kg (132 LBS)?



Oui - Parfait !

Non - Ce support ne vous convient pas !

3 De quels genres matériaux le mur est fait ?

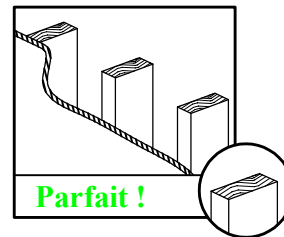
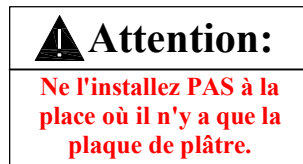

Cloison sèche avec montant en bois ?

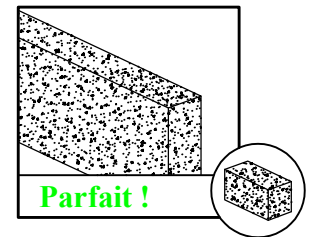

Mur en béton plein ?

4 Outils d'installation (Pas inclus)

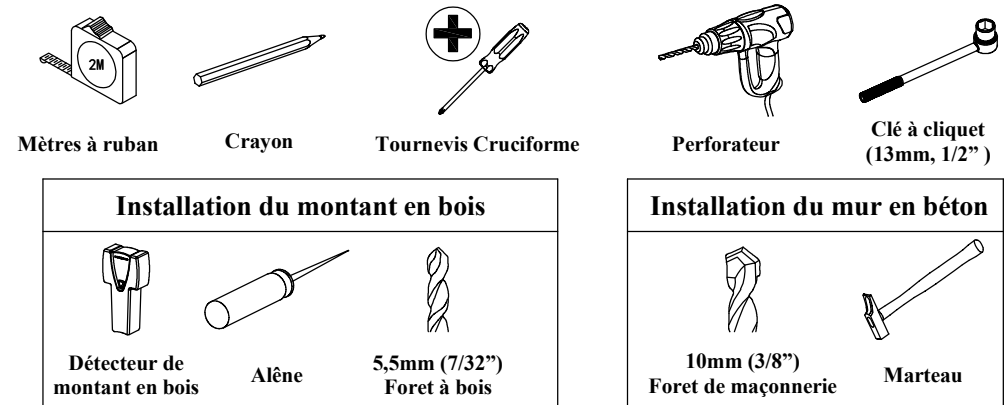

5 Consignes de sécurité

Avant l'installation, veuillez attentivement lire ce mode d'emploi.

Si vous ne pouvez pas comprendre ces instructions, ou si vous avez des questions sur la sécurité de l'installation, de l'assemblage et de l'utilisation, contactez S.V.P. le service client par email: customerservice@mountingdream.com. Ou appelez-nous au (626) -604-9048 (USA). Temps de travail: du lundi au vendredi de 10h à 18h (Heure du Pacifique)

- Ce produit s'applique au montant en bois, au mur en béton plein - Ne l'installez pas à la place où il n'y a que la plaque de plâtre.
- La force portante du mur doit atteindre au moins cinq fois du poids total de votre téléviseur et du support.
- N'utilisez pas ce produit pour des autres objectifs non désignés par Mounting Dream.
- L'installation incorrecte causera le dommage matériel ou la blessure corporelle. Mounting Dream n'assumera aucune responsabilité pour le dommage et la blessure causés par l'installation incorrecte ou l'utilisation inadéquate.

⚠ AVERTISSEMENT : Ce produit contient des petites pièces, en cas d'ingestion, des risques de suffocation y arrivera. Avant l'installation, veuillez vérifier que tous les accessoires et toutes les pièces sont complets et non défectueux. S'il y a des pièces manquantes ou endommagées, contactez S.V.P. le service client par email : customerservice@mountingdream.com.

ATTENTION : Les pièces fournies ne seront pas toutes utilisées durant l'installation.

Étape 1 Installer des barres verticales sur votre téléviseur Voir à la page 2

Pièces et accessoires

1-1 Choisir des vis de téléviseur

1-2 Entretoises sont nécessaires ?

I Non, voir à la page 3, combinaison **I** .

II Oui, voir à la page 3, combinaison **II** .

1-3 Assembler des barres verticales

Remarque : Quand vous choisissez la vis M6(e) / M8(c / f) et l'entretoise (j) de 2,5mm est nécessaire, veuillez enlever la cerce interne.

Étape 2 Installer la plaque murale au mur

Pièces et accessoires

Étape 2A Installation du montant en bois Voir à la page 4

⚠ Attention : Quand vous installez la plaque murale au mur avec le poteau de bois, n'utilisez pas les chevilles!

⚠ Attention : Tous les quatre boulons tire-fond **01** doivent être fermement serrés pour éviter le mouvement non souhaité de la plaque murale. Veuillez vérifier que la plaque murale est fixée sur le mur avant de passer à l'étape suivante. Après avoir fini cette étape, allez directement à la page 7 et continuez l'étape 3.

Pour éviter que le téléviseur ne tombe, la tête du boulon doit faire face vers le haut !!

Étape 2B Installation du mur en béton plein Voir à la page 6

⚠ Attention : Tous les quatre boulons tire-fond **01** doivent être fermement serrés pour éviter le mouvement non souhaité de la plaque murale. Veuillez vérifier que la plaque murale est fixée sur le mur avant de passer à l'étape suivante.

Pour éviter que le téléviseur ne tombe, la tête du boulon doit faire face vers le haut !!

Étape 3 Suspendre et fixer votre téléviseur sur la plaque murale Voir à la page 7

Pièces et accessoires

Test de la fiabilité de l'installation de la plaque murale

Avant de suspendre votre téléviseur sur la plaque murale, veuillez tester la fiabilité de l'installation de la plaque murale.

Suspendre et fixer votre téléviseur sur la plaque murale

⚠ Attention : Après avoir suspendu votre téléviseur sur la plaque murale, veuillez bien serrer les vis de sécurité **04** au tournevis cruciforme pour assurer qu'elles sont fixes.

*Compte tenu de la sécurité, deux personnes sont nécessaires pour l'installation.

Étape 4 Ajustement de fonction Voir à la page 8

4-1 L'ajustement de l'angle d'inclinaison (+5°/-15°)

Tout d'abord, desserrer la poignée, puis ajuster votre téléviseur à l'angle souhaitée, bien serrer la poignée.

Serrer ou desserrer la poignée :

- ① Tourner (serrer ou desserrer) la poignée jusqu'elle est arrêtée par le support.
- ② Tirer vers l'extérieur et tenir la poignée.
- ③ Tourner la poignée vers la direction inverse.
- ④ Pousser et libérer la poignée.
- ⑤ Tourner de nouveau la poignée pour le serrer ou desserrer.

4-2 L'ajustement du niveau (+/-3°)

Desserrer à la clé hexagonale **03** les deux vis de niveau à l'arrière de la plaque TV (pas plus de deux tours), ajuster le niveau et puis serrer les vis.

Étape 5 gestion des câbles Voir à la page 9

Dimensions de produit Voir à la page 10

Antes de comenzar a instalar este soporte mural para tv , favor confirme si es el adecuado para su televisor!

1 Los orificios posteriores de su televisor tienen una distancia mayor o igual a 200x100mm/8x4" y menor o igual a 600x400mm/24x16"?

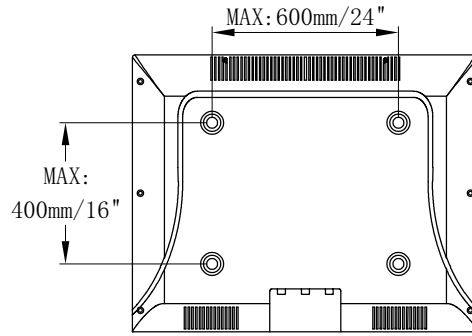

Si - Es el adecuado!

No - Este soporte no es el adecuado!

2 El peso de su televisor y los demás accesorios en total es menor a 60 kg (132 LBS)?



Si - Es el adecuado!

No - Este soporte no es el adecuado!

3 La pared de que material esta construida?

Atención:
En paredes de yeso o derivados no se debe instalar.

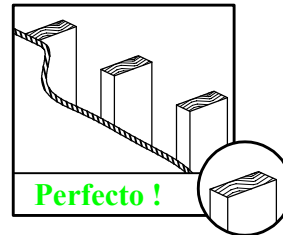

Perfecto !
Instalar en paredes con pilares de madera?

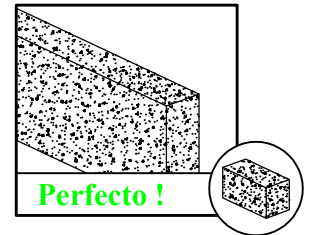

Perfecto !
Instalar en paredes de hormigón sólido ?

4 Herramientas necesarias para su instalación (No incluido)

Cinta Métrica	Lápiz	Destornillador de Cruz	Taladro Eléctrico	Juego de llaves (13mm, 1/2")
Instalación en pared con pilares de madera			Instalación en pared de hormigón	
Detector de Madera	Punzón	5,5mm (7/32") Broca para Madera	10mm (3/8") Broca de Impacto	Martillo

5 Advertencias de seguridad

Antes de la instalación favor de leer en detalle el manual de instrucciones. Si no comprende el manual de instrucciones, la instalación segura del producto, o si en el montaje y/o la utilización tiene alguna duda, favor de contactarse vía mail a nuestro servicio al cliente: customerservice@mountingdream.com. O llámenos al (626) -604-9048 (USA). Horario de oficina: de lunes a viernes, de 10 a.m. a 6 p.m. (Hora del Pacífico)

- Este producto es apto para paredes con pilares de madera, y muro de hormigón sólido - No instalar en paredes de solo yeso.
- La capacidad de soporte de la pared debe ser cinco veces más que el peso total del televisor y el soporte.
- Favor NO utilizar el producto de Mounting Dream para otros usos no asignados.
- La instalación incorrecta puede producir daños al producto o lesiones al usuario. Cualquier pérdida o daño debido por la mala instalación o uso indebido, Mounting Dream no asume ninguna responsabilidad.

Instrucciones paso a paso de su instalación

⚠ Advertencia: Este producto contiene piezas pequeñas, si por error se ingiere, puede provocar peligro de asfixia. Antes de comenzar la instalación, favor compruebe que todos los accesorios y piezas de repuesto estén completas y sin daño alguno. Si faltan o están dañadas, favor de contactarse con nuestro servicio al cliente: customerservice@mountingdream.com.

Atención: No todas las piezas se utilizarán.

Paso 1 Instalar las varillas del soportes al televisor Ver página 2

Accesorios y piezas

1-1 Elegir los tornillos para el televisor

1-2 Necesito espaciadores?

I No necesito, favor ver la combinación **I** en la página 3.

II Necesito, favor ver la combinación **II** en la página 3.

1-3 Instalar las varillas del soporte

Tips: Si necesita espaciadores de 2,5mm (j) combinados con tornillos de M6(e) / M8(c / f), favor retirar la argolla/anillo.

Paso 2 Instalar la placa mural

Accesorios y piezas

Paso 2A Instalación en pared con pilares de madera Ver página 4

⚠ Atención: Al momento de instalar el panel en la pared con pilares de madera, favor no usar los tacos/tarugos para la pared de hormigón!

⚠ Atención: Los cuatro tornillos **01** de cabeza hexagonal deben apretarse firmemente, para evitar que la placa mural en la pared se mueva. Favor de asegurarse que quede firmemente estable en la pared para poder continuar con los siguientes pasos de la instalación. Luego de terminar este paso favor continuar con el paso 3 en la página 7.

Para prevenir que el televisor se caiga, durante este paso, la cabeza del tornillo debe ir hacia arriba! !

Paso 2B Instalación en pared de hormigón sólido Ver página 6

⚠ Atención: Los cuatro tornillos **01** de cabeza hexagonal deben apretarse firmemente, para evitar que la placa mural en la pared se mueva. Favor de asegurarse que quede firmemente estable en la pared para poder continuar con los siguientes pasos de su instalación.

Para prevenir que el televisor se caiga, durante este paso, la cabeza del tornillo debe ir hacia arriba! !

Paso 3 Colgar y sujetar del televisor a la placa mural Ver página 7

Accesorios y piezas

Prueba de confiabilidad a la instalación de la placa mural

Antes de colgar el televisor en la placa mural, favor realizar una prueba de confiabilidad a la instalación.

La colocación y sujeción del televisor a la placa mural

⚠ Atención: Después de colgar el televisor en el soporte mural, favor use el destornillador para apretar los tornillos **04** de seguridad, asegurando que no haya ningún afloje.

* Por razones de seguridad, para concluir este paso es mejor hacerlo en compañía de otra persona.

Paso 4 Funciones de regulación Ver página 8

4-1 Regulación del ángulo de inclinación (+5°/-15°)

Primero afloje la manilla, luego ajuste su televisor al ángulo deseado, y por último vuelva a apretar la manilla.

Para apretar o aflojar la manilla:

① Gire la manilla (aflojar o apretar) hasta el tope de esta, hasta que ya no pueda girar.

② Tire hacia fuera y sostenga la manilla.

③ Gire la manilla en la dirección opuesta.

④ Presione y suelte la manilla.

⑤ Gire la manilla nuevamente para apretar o aflojar.

4-2 Regulación de nivel (+/-3°)

Use una llave hexagonal **03** y afloje (máximo 2 vueltas) los 2 tornillos de nivelación que están detrás de la placa del televisor, regule el nivel, y luego vuelva a apretar los tornillos.

Paso 5 mantenimiento de cable Ver página 9

Dimensiones del producto Ver página 10

Prima di iniziare l'installazione, per prima cosa conferma se questo Supporto è ideale per la vostra TV!

1 La distanza dei fori di installazione TV sono superiore/uguale a 200x100mm/8x4" e inferiore /uguale a 600x400mm/24x16"?

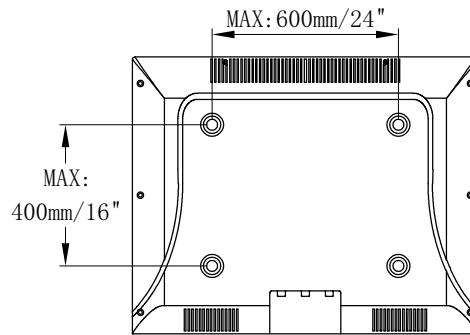

Sì - Ideale!

No - Questo supporto non va!

2 Il tuo televisore (inclusi accessori) pesa totalmente inferiore a 60 kg (132 LBS)?



Sì - Ideale!

No - Questo supporto non va!

3 Di che materiale è fatto il muro?

⚠ Cautela:
Non installarlo in un posto solo in cartongesso.

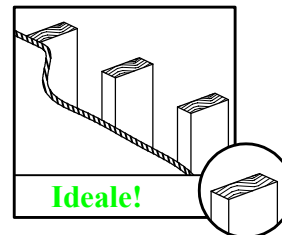

Muro secco con i pilastri in legno?

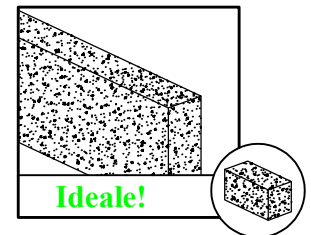

Muro in calcestruzzo solido ?

4 Utensili per installazione (Non incluso)

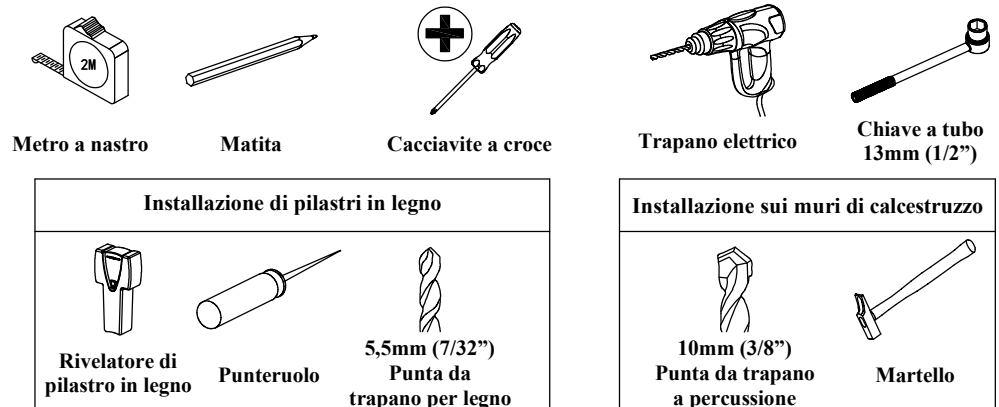

5 Cautele per sicurezza

Leggi attentamente le istruzioni prima di installazione.

Se non puoi comprendere queste istruzioni o se vi sono dubbi sull'installazione sicura, sull'assemblaggio e sull'utilizzo di questo prodotto, contatta il Servizio Clienti tramite e-mail: customerservice@mountingdream.com. Oppure chiamaci al numero (626) -604-9048 (USA). Orario d'ufficio: dal lunedì al venerdì, dalle 10:00 alle 18:00 (ora del Pacifico)

- Questo prodotto è progettato per pilastri in legno e muri in calcestruzzo solido - NON installarlo in soli cartongessi.
- Il muro deve essere capace di portare almeno cinque volte il peso totale del televisore e del supporto.
- Non applicare questo prodotto ad altri scopi non indicati da Mounting Dream.
- L'installazione errata potrebbe causare danni al prodotto o lesioni personali. Mounting Dream non si assume alcuna responsabilità per danni o lesioni causate da installazione impropria o uso improprio.

Istruzioni di installazione

⚠ Avvertenza: Questo prodotto contiene piccoli articoli che potrebbe causare il pericolo di soffocamento se ingoiati. Prima di iniziare l'installazione, controlla se tutti gli accessori e parti siano inclusi e non danneggiati. In caso di perdita o danni, contatta il Servizio Clienti via mail: customerservice@mountingdream.com.

Nota: Non verranno utilizzati tutte le parti incluse.

Passo 1 Installa barre verticali al televisore Vedi pagina 2

Accessori e parti

1-1 Seleziona viti TV

1-2 Si ha bisogno di pilastri con guarnizione?

I No, vedi la combinazione **I** nella pagina 3.

II Sì, vedi la combinazione **II** nella pagina 3.

1-3 Installazione di barre verticali

Suggerimento: se è necessario combinare il pilastro con guarnizione 2,5mm (j) con la vite M6(e) / M8(c / f), rimuovi l'anello interno.

Passo 2 Installa la piastra a muro sul muro

Accessori e parti

Passo 2A Installazione sul muro con i pilastri in legno Vedi pagina 4

⚠ Cautela: Quando si installa la piastra a muro sul muro con pilastri in legno, non utilizzare i tasselli per il muro in calcestruzzo!

⚠ Cautela: Le quattro viti **01** per Legno a testa esagonale devono essere avvitate bene in modo da evitare movimenti indesiderati della piastra a muro. Assicura che la piastra a muro sia ben fissata sul muro prima di eseguire il prossimo passo. Dopo finire questo passo, va direttamente alla pagina 7 per il passo 3.

Per evitare che la TV cada, la testa del bullone deve essere rivolta verso l'alto!!

Passo 2B Installazione sul muro in calcestruzzo Vedi pagina 6

⚠ Cautela: Le quattro viti **01** per Legno a testa esagonale devono essere avvitate bene in modo da evitare movimenti indesiderati della piastra a muro. Assicura che la piastra a muro sia ben fissata sul muro prima di eseguire il prossimo passo.

Per evitare che la TV cada, la testa del bullone deve essere rivolta verso l'alto!!

Passo 3 Appendi e fissa la TV alla piastra a muro Vedi pagina 7

Test di affidabilità dell'installazione della piastra a muro

Prima di appendere la TV alla piastra a muro, esegui un test di affidabilità dell'installazione della piastra a muro.

Appendi e fissa la TV alla piastra a muro

⚠ Cautela: Dopo appendere la TV alla piastra a muro, avvita bene le viti **04** di sicurezza con un cacciavite assicurando che non si allenti.

* Per la sicurezza, è meglio eseguire questo passo da due persone.

Passo 4 Regolazioni di funzione Vedi pagina 8

4-1 Regolazione dell'angolo di inclinazione (+5°/-15°)

Prima, allenta la maniglia, quindi gira la TV all'angolo desiderato, infine stringi la maniglia per fissare l'angolo di inclinazione.

Stringi o allenta la maniglia:

- ① Gira (allenta o stringi) la maniglia fino a quando non è possibile ruotarla ancora.
- ② Tira fuori la maniglia e tienila.
- ③ Gira la maniglia in senso inverso.
- ④ Spingi la maniglia e rilasciala.
- ⑤ Gira di nuovo la maniglia per stringere o allentare.

4-2 Regolazione di livello (+/-3°)

Allenta (due cerchi al massimo) con la chiave a brugola interna **03** le due viti di livellamento sul retro della piastra TV, le regola al livello e le avvita nuovamente per fissarle.

Passo 5 gestione dei cavi Vedi pagina 9

Dimensioni del prodotto Vedi pagina 10