



Mounting Dream

MD2104 INSTALLATION INSTRUCTION

Für die Installationsanweisungen auf Deutsch, siehe Seite 10~11.

Pour l'instruction en Français, veuillez vous reporter à la page 12~13.

Para las instrucciones de la instalación en Español, favor vea la página 14~15.

Per le Istruzioni in Italiano, vedi pagina 16~17.

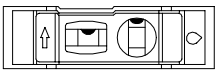
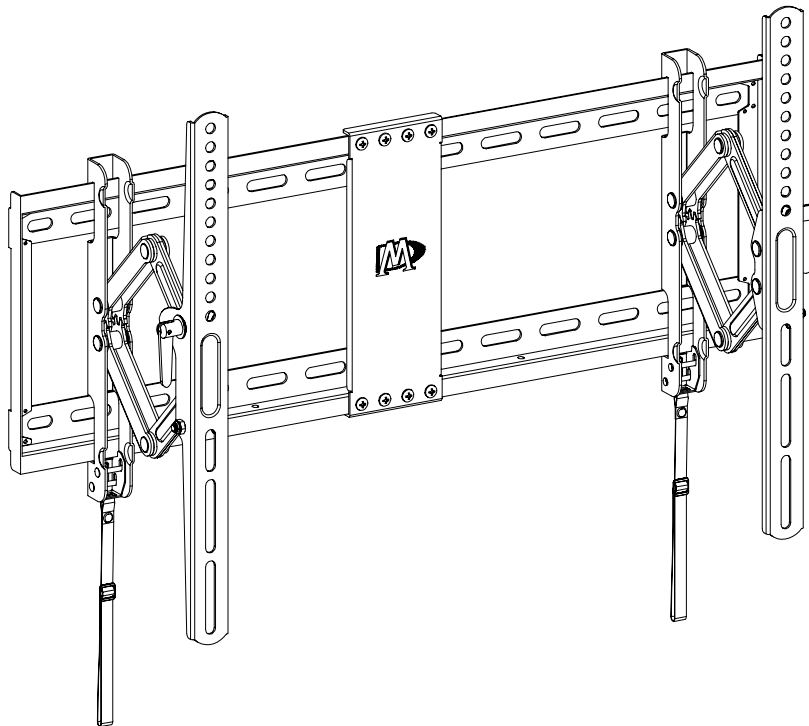

x1

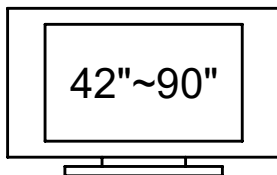

Max:600x400mm/24x16"
Min:200x100mm/8x4"

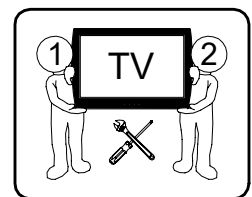

(C1)

Before getting started, let's make sure this mount is perfect for you!

1 Is your TV VESA equal to/greater than 200x100mm/8x4" and equal to/less than 600x400mm/24x16"?

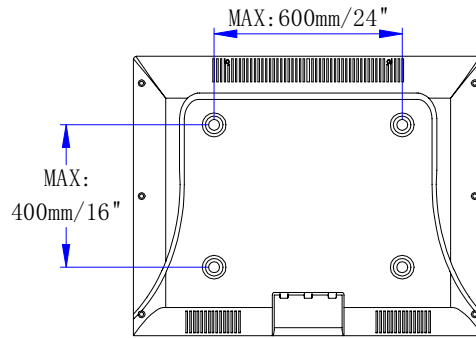

Yes --- Perfect!

No --- This mount is **NOT** compatible.

2 Does your TV (including accessories) weigh less than 120 LBS (54.5 kg)?



Yes --- Perfect!

No --- This mount is **NOT** compatible.

3 What is your wall made of?

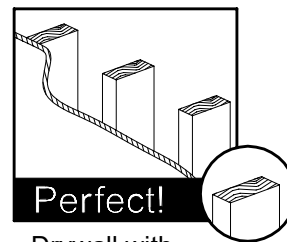

Drywall with wood studs?

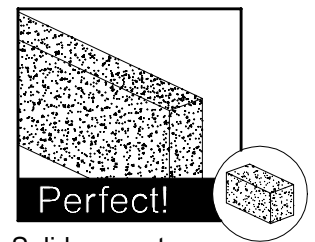

Solid concrete wall?

4 Installation Tools (Not Included)

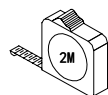

Band Tape



Pencil

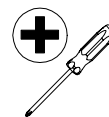

Screwdriver

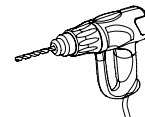

Electrodrill

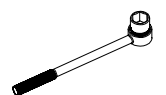

Socket Wrench 1/2"(13mm)

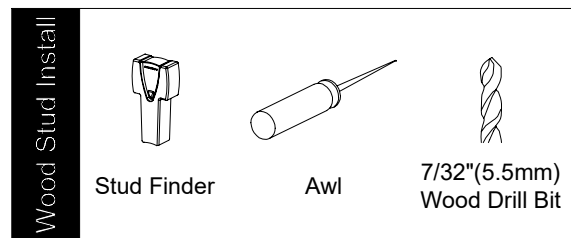

Stud Finder

Awl

7/32"(5.5mm) Wood Drill Bit

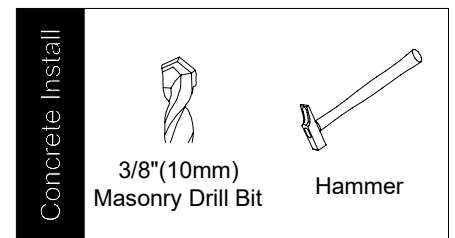

3/8"(10mm) Masonry Drill Bit

Hammer

5 Safety Caution

Please read this instruction carefully before installation.

- This product is designed for use in wood stud and solid concrete wall. - DO NOT install into drywall alone.
- The wall must be capable of supporting five times the weight of the TV and mount combined.
- Incorrect installation may result in product damage or body injury. Mounting Dream shall bear no responsibility for any damage or injury resulted from incorrect installation, incorrect assembly or misuse.
- Do not apply this product to any purpose not indicated by Mounting Dream.

STEP 1 Attach Brackets to TV

Parts and Hardware

! WARNING: This product contains small items that could be a choking hazard if swallowed. Before starting assembly, verify all parts are included and undamaged.

NOTE: Not all hardware included will be used.

TV Screws

M6x12mm

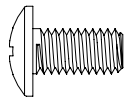

a x4

M6x35mm

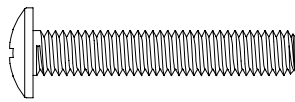

c x4

M8x25mm

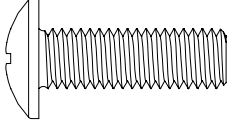

b x4

M8x45mm

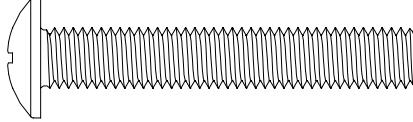

d x4

Spacers

M6x17mm

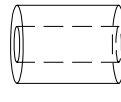

e x4

M8x22mm

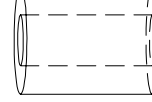

f x4

M8x10mm

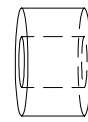

g x4

M8x2.5mm



h x8

Washers

M6

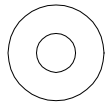

i x4

Wall mounting and TV bracket assembly hardware

Lag Bolt M8x60mm

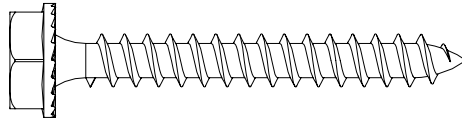

01 x4

M5x8mm Bolt



02 x4

Wall plate(Left)

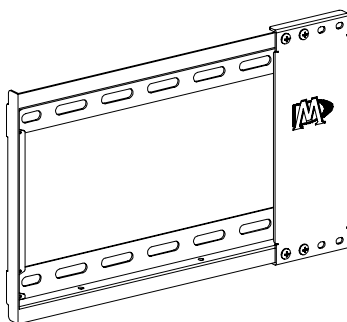

03 x1

Wall plate(Right)

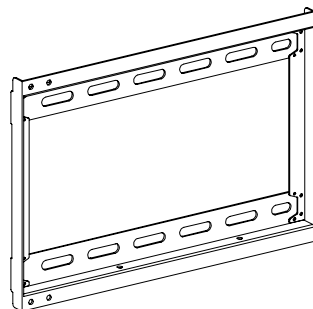

04 x1

TV bracket

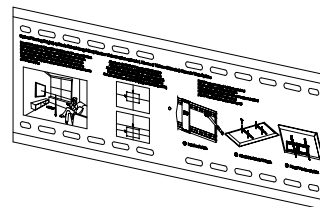

Mounting
Template



05 x1

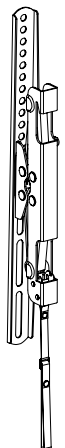

06 x1

STEP 1 Attach Brackets to TV

1-1 Select TV Screws

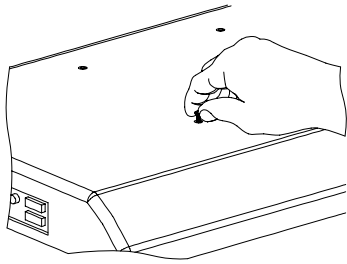

M6 M8

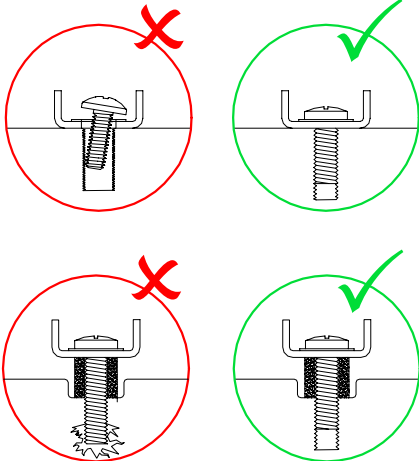

1-2 Need Spacer?

I No, go to PAGE 3 **I** for detailed combination.

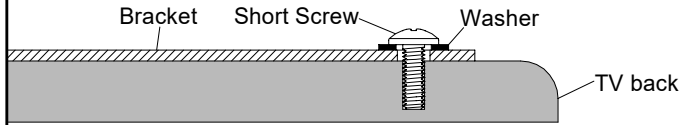

II Yes, go to PAGE 3 **II** for detailed combination.

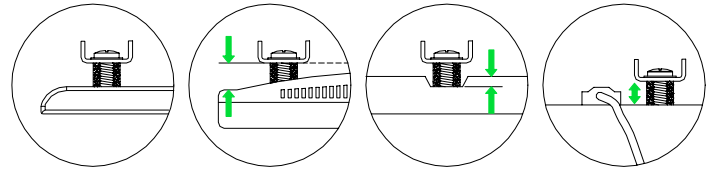
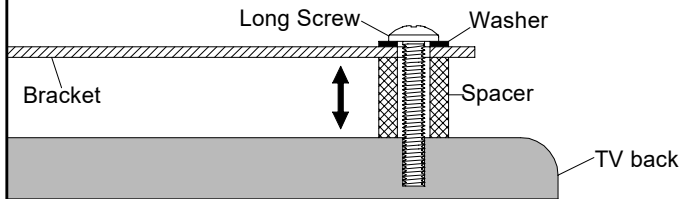

1-3 Attach the TV Brackets

NOTE: Choose proper washer or spacer that fits your particular TV mounting holes.

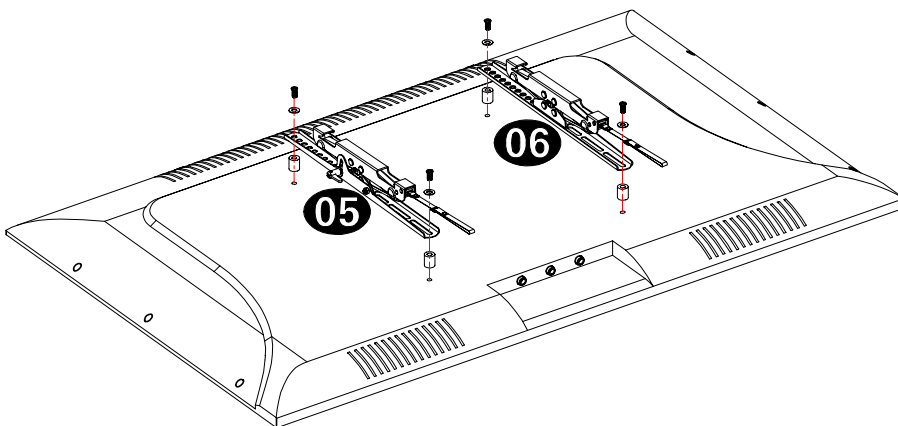

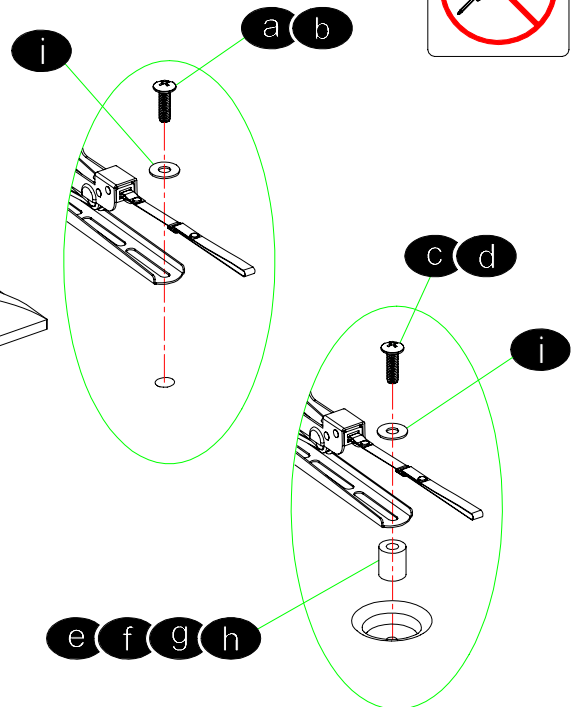

I Screw and washer



Tips: If you need to combine M6(c) or M8(b/d) screw with 2.5mm spacer(h), you have to remove the inner circle.

II Spacer(s) screw and washer

STEP 2 Attach Wall Plate to Wall

-  For wood stud installation, follow STEP 2A
-  For concrete installation, follow STEP 2B on PAGE 9

Assemble Wall plate

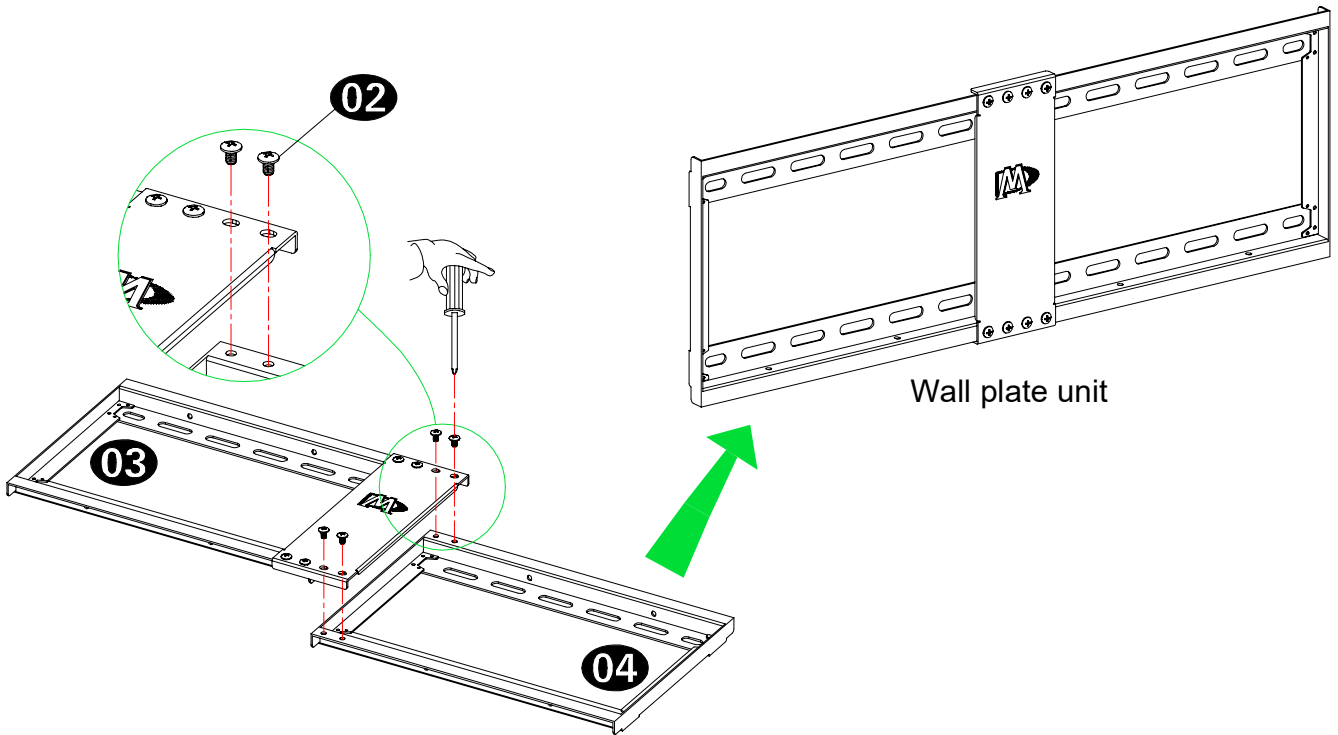

STEP 2A Wood Stud Installations

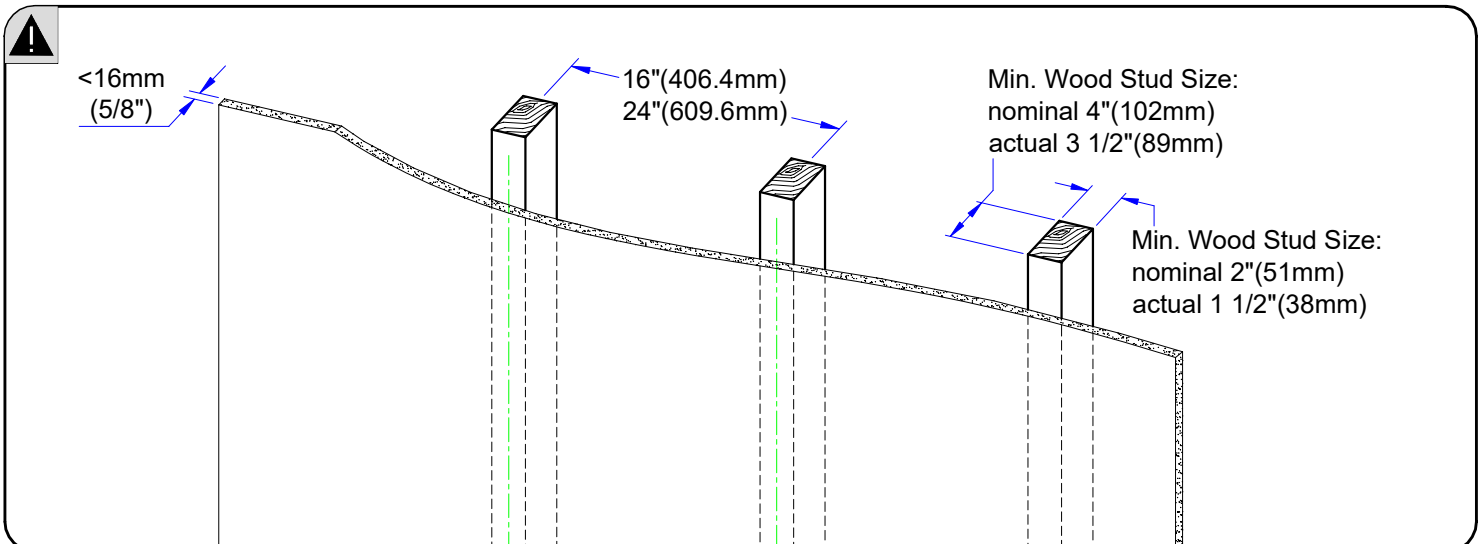

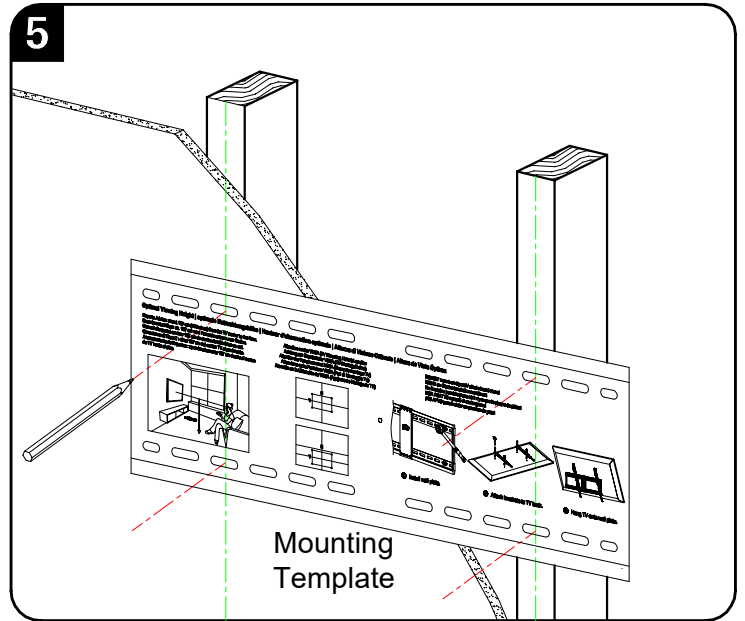
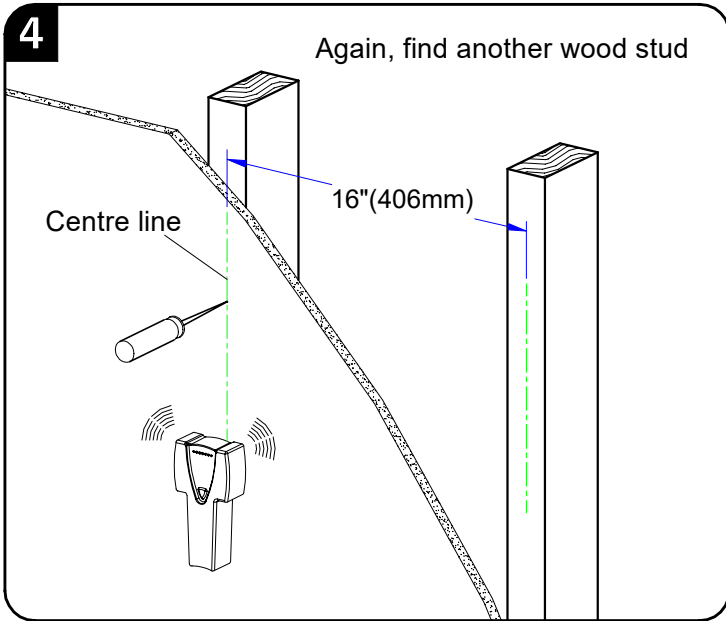
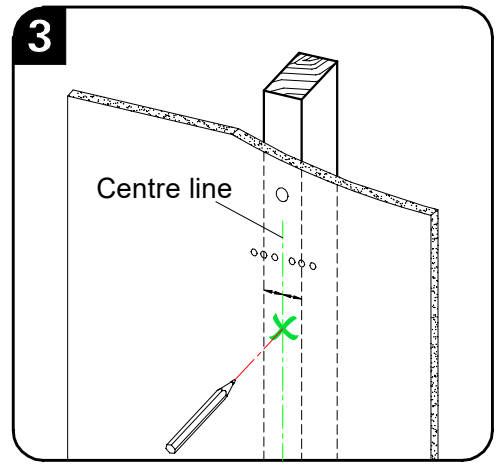
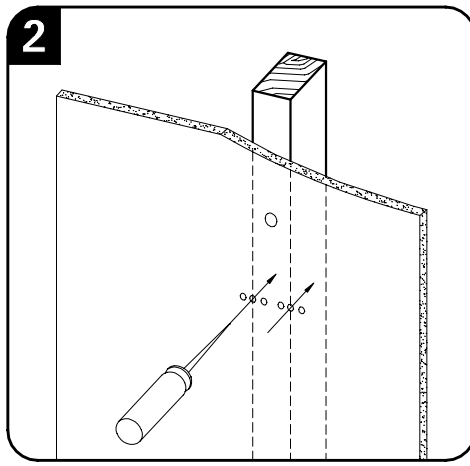
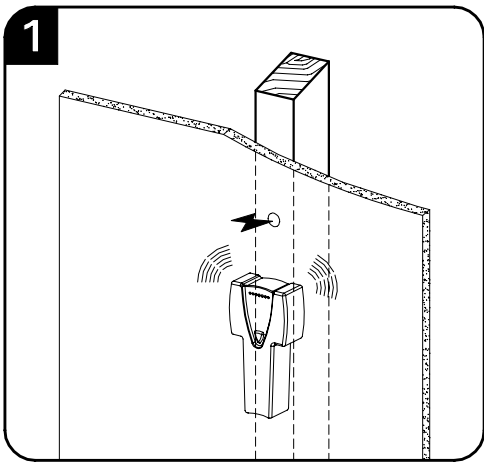

⚠ CAUTION: To avoid potential personal injury or property damage:
 All 4 lag bolts **01** MUST BE firmly tightened to prevent unwanted movement of the wall plate assembly. Ensure the wall plate assembly is securely fastened to the wall before continuing on to the next step.

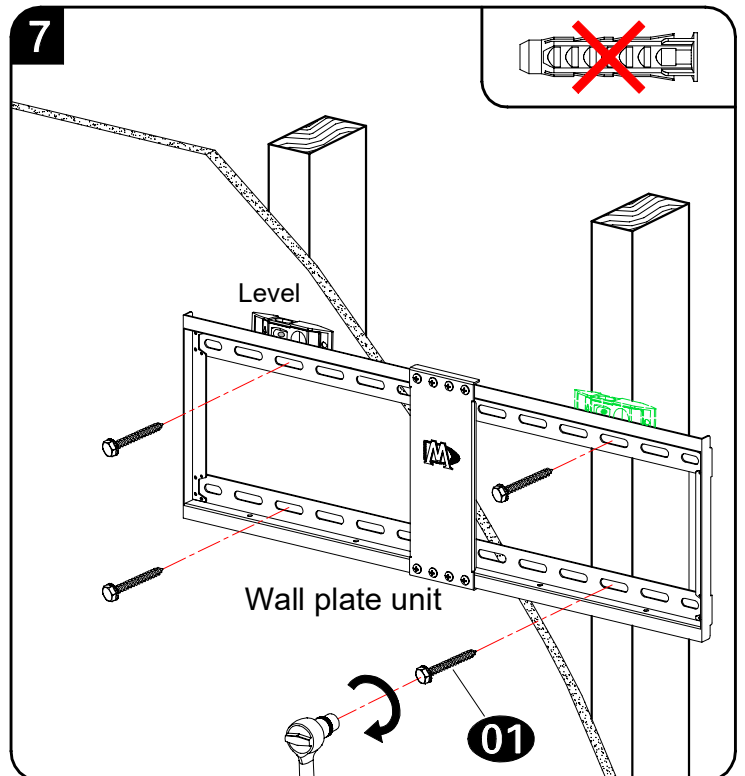
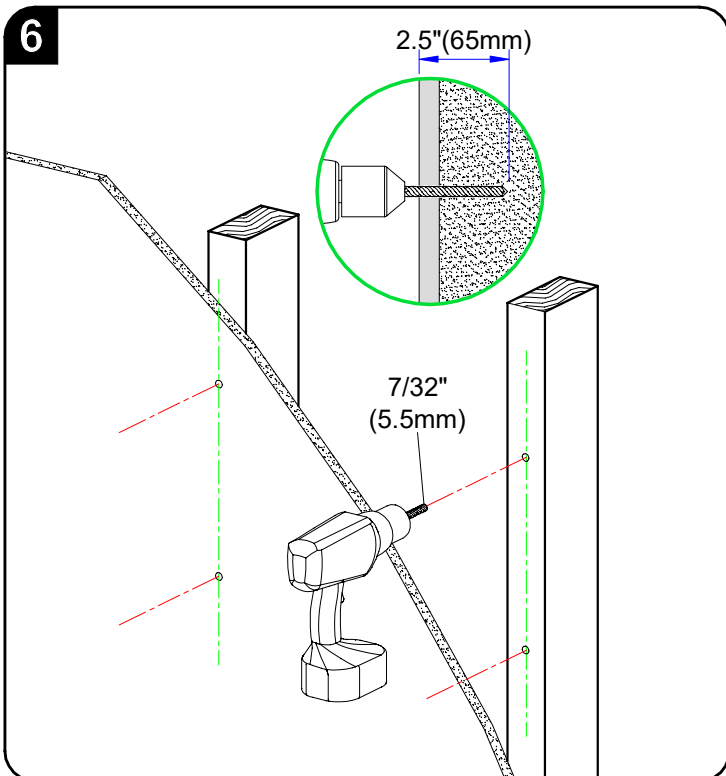

Go to Step 3 on PAGE 6.

STEP 3 Hang and Secure TV to Wall Plate

Before hanging TV, please conduct "wall plate installation integrity test" first.

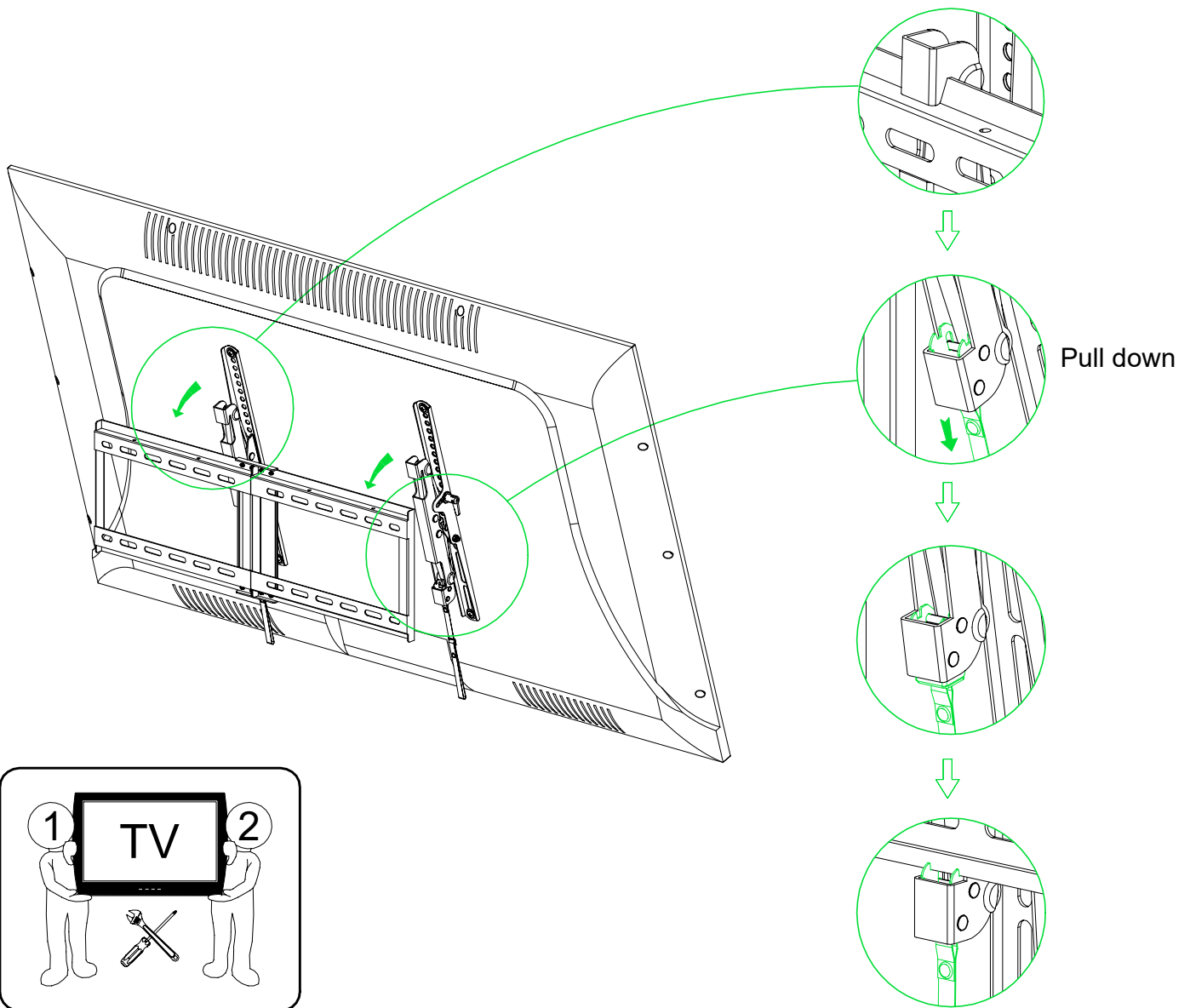
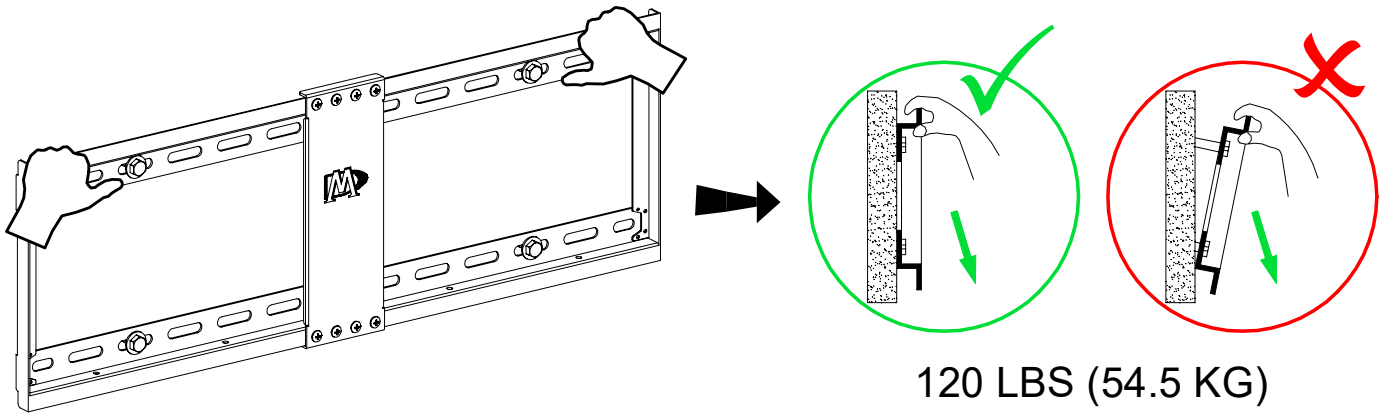

STEP 4 Adjustments

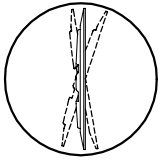

Tilting angle adjustment ($+2^{\circ}/-15^{\circ}$):
Loosen handle by maximum 1/2 turns, adjust TV to your desired position, then tighten handle.

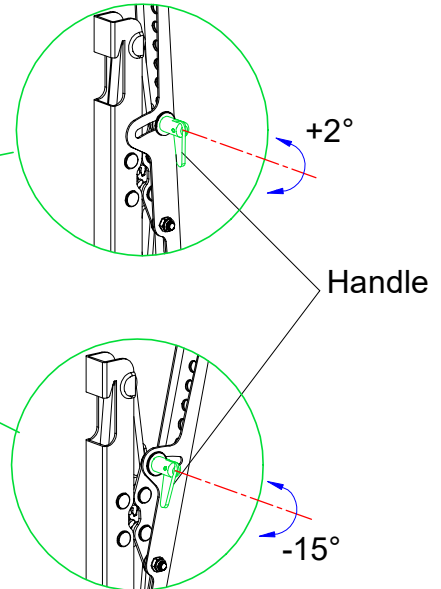
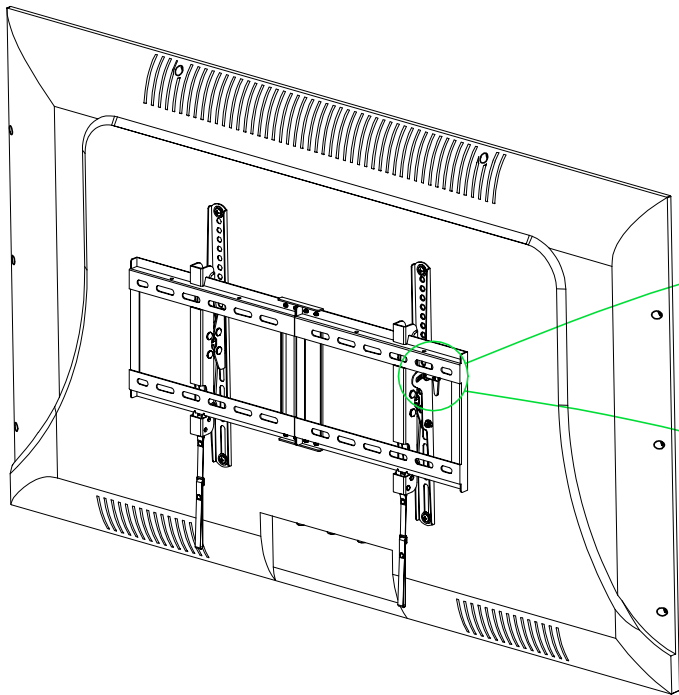

Adjustable distance from wall

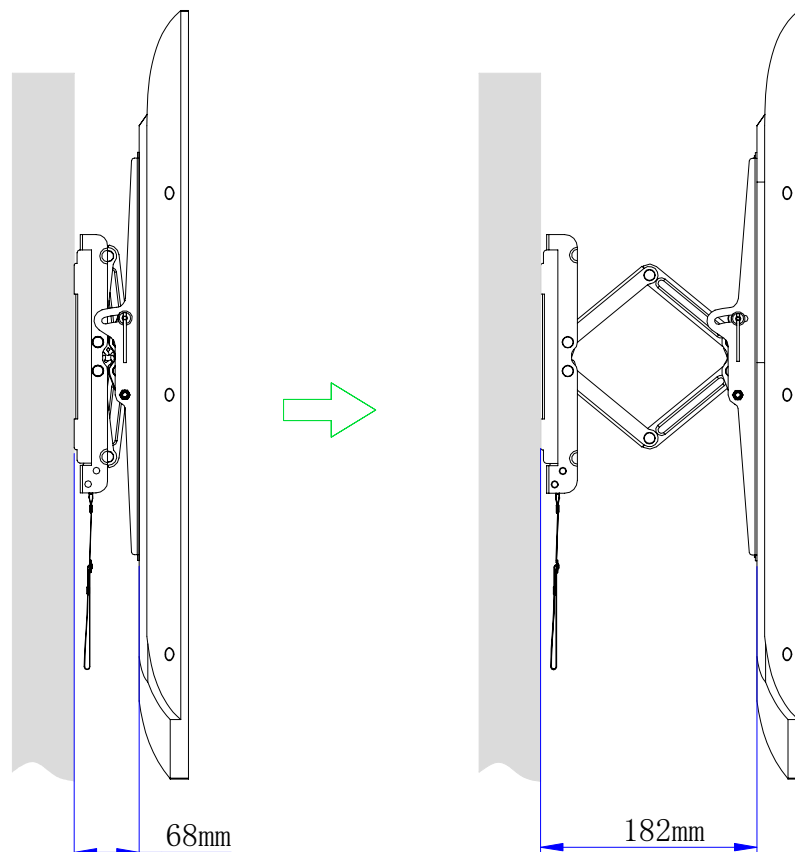

STEP 5 Take Down the TV from the Mount

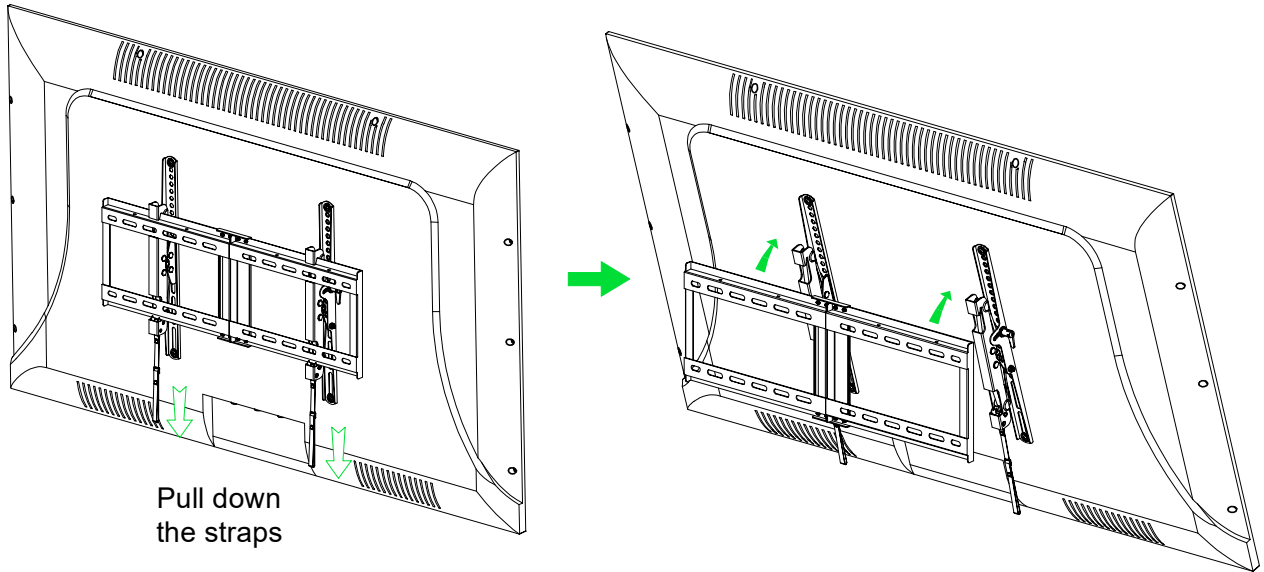

Product dimensions:

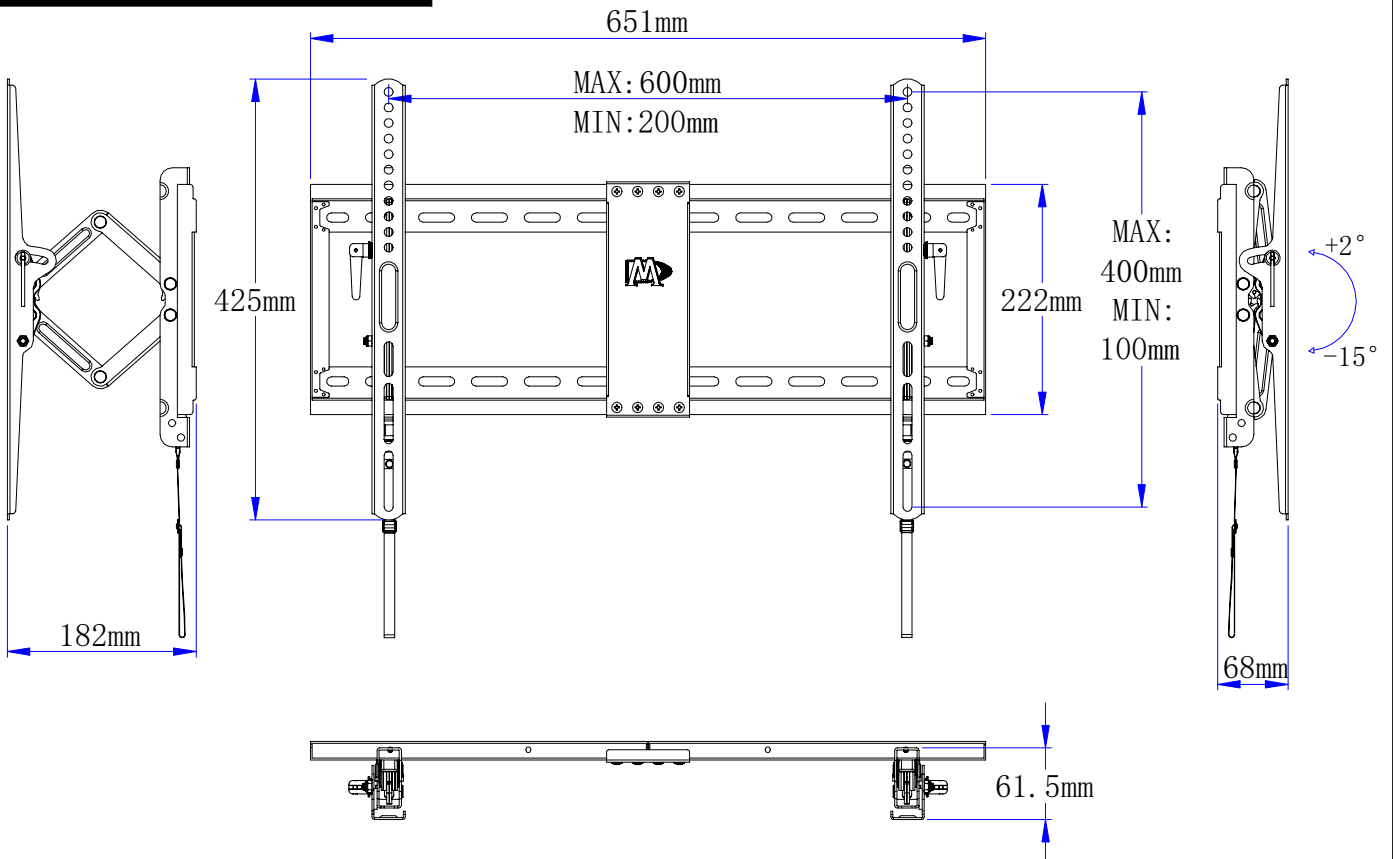

STEP 2B

Solid Concrete Wall Installation

Concrete wall anchor (NOT INCLUDED)

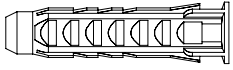

Concrete Wall Anchor 4pcs
(Anchor Size: $\phi 10 \times 50 \text{mm}$)

If you do need concrete anchor,
please contact us Via Amazon to
get it.

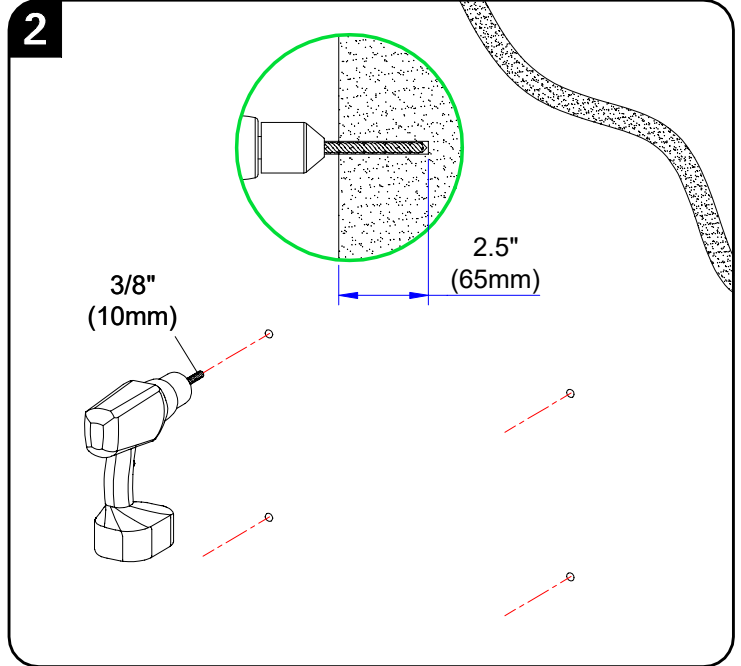
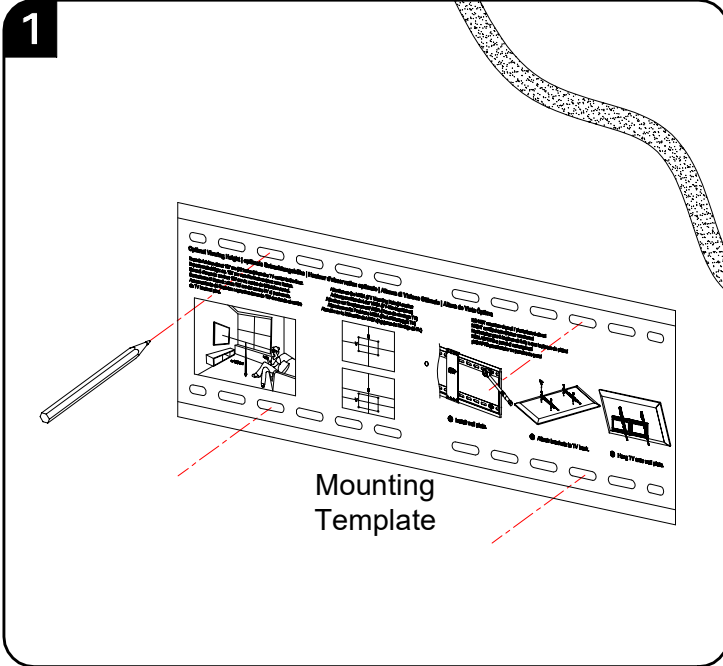
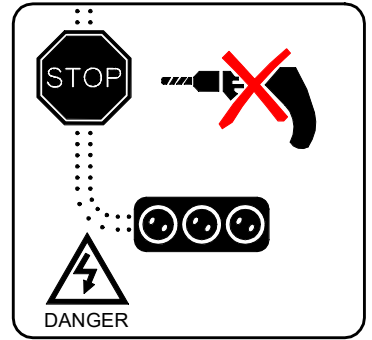
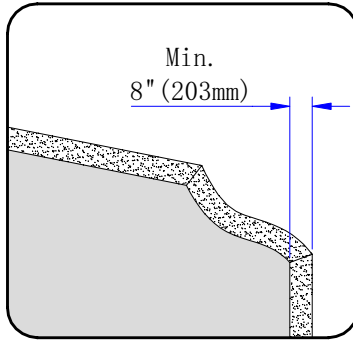

⚠ CAUTION: To avoid potential personal injury or property damage:
All 4 lag bolts **01** MUST BE firmly tightened to prevent unwanted movement of the wall plate assembly. Ensure the wall plate assembly is securely fastened to the wall before continuing on to the next step.

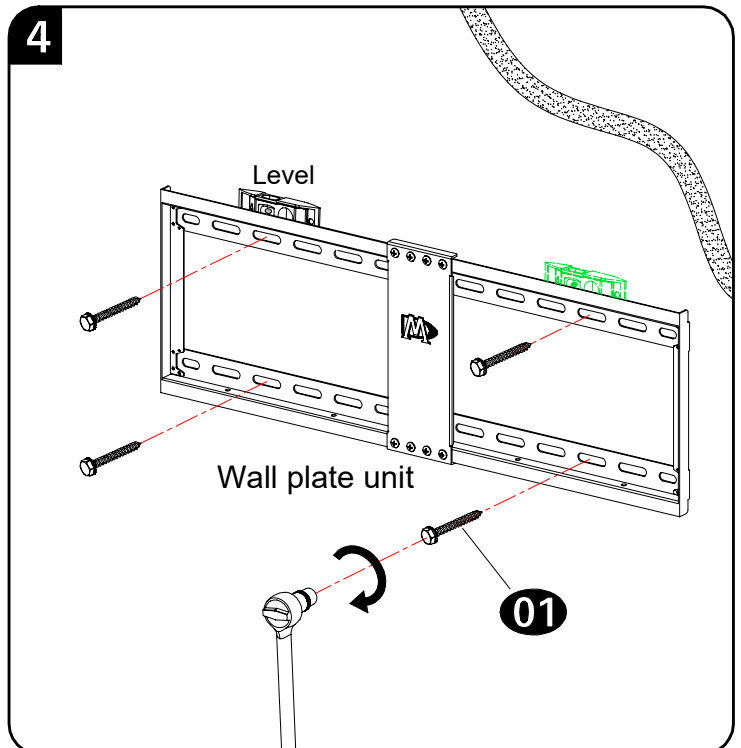
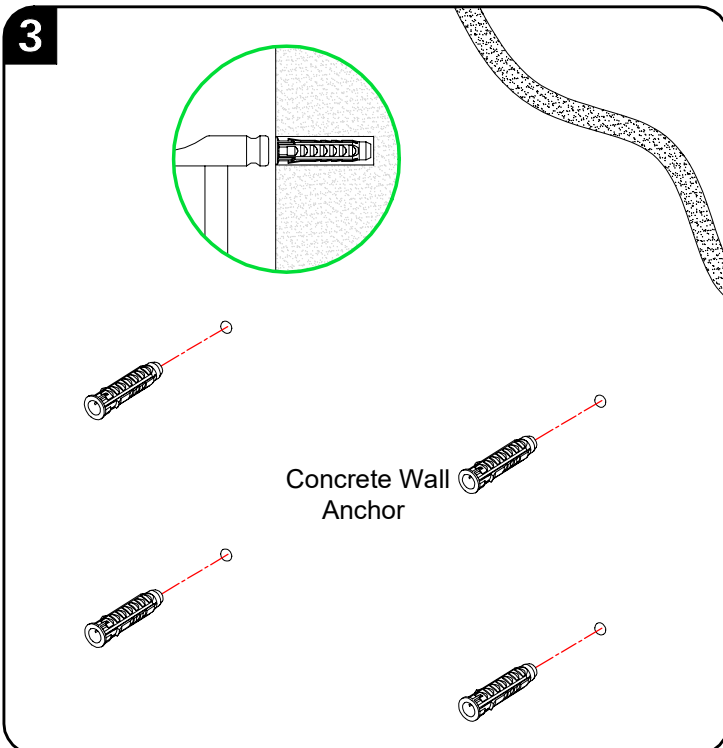

Vor der Installation bestätigen Sie bitte zuerst, ob diese Halterung für Ihr Fernsehapparat geeignet ist!

1 Ist der Abstand der Montagelöcher von Ihrem Fernsehapparat zwischen 200x100mm/8x4" und 600x400mm/24x16"?

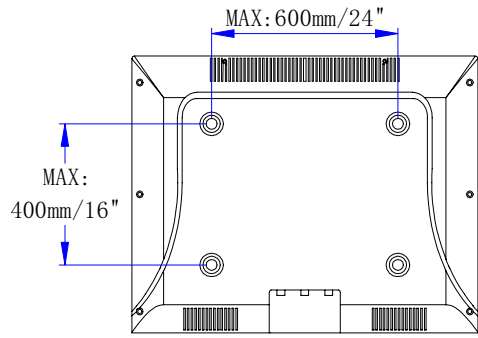

Ja - Perfekt!

Nein - Diese Halterung ist nicht geeignet!

2 Wiegt Ihr Fernsehapparat (inkl. Zubehör) weniger als 54.5 KG (120 LBS)?



Ja - Perfekt!

Nein - Diese Halterung ist nicht geeignet!

3 Woraus besteht Ihre Wand?

⚠ Vorsicht:
NICHT an einer reinen Gipskartonwand anbringen.

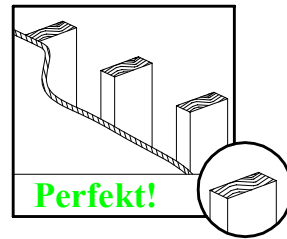

Gipskartonwand mit Holzbalken?

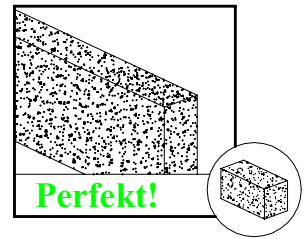

Massivbetonwand?

4 Werkzeuge für Installation (Nicht enthalten)

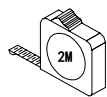

Bandmaß



Bleistift

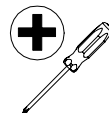

Kreuzschlitzschraubendreher

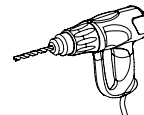

Elektrobohrer

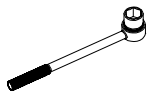

Steckschlüssel (13mm, 1/2")

Montage von Holzbalkenwand

Balkensucher Ahle 5.5mm (7/32") Bohreinsatz für Holz

Montage von Betonwand

10mm (3/8") Bohreinsatz für Stein Hammer

5 Sicherheitshinweise

Bitte lesen Sie die Anweisungen sorgfältig vor der Installation durch.

- Dieses Produkt ist für die Installation an Wänden mit Holzträgern und Massivbetonwand - NICHT an einer reinen Gipskartonwand montieren.
- Die Wand muss das Fünffache des Gesamtgewichts des Fernsehapparats und der Halterung tragen können.
- Verwenden Sie dieses Produkt nicht für einen anderen Zweck als speziell von Mounting Dream angegeben.
- Unsachgemäße Montage dieses Produkts kann zu Verletzungen und zu den Beschädigungen an Ihrem Gerät führen. Mounting Dream haftet nicht für Schäden oder Verletzungen, die durch unsachgemäße Montage, unsachgemäßen Zusammenbau oder unsachgemäße Verwendung verursacht wurden.

Installationsanweisungen

⚠ Warnung: Dieses Produkt enthält kleine Teile, die beim Verschlucken zur Erstickengefahr führen können. Bevor Sie mit der Installation beginnen, überprüfen Sie bitte, ob alle Zubehörteile und Ersatzteile vollständig und unbeschädigt sind.

Hinweis: Es wird nicht das gesamte mitgelieferte Befestigungsmaterial verwendet.

Schritt 1 Befestigen Sie die Schienen am Fernseher Siehe Seite 2

Mitgelieferte Teile und Befestigungsmaterialien

1-1 Wählen Sie Schrauben für den Fernseher aus

1-2 Abstandhalter?

I Wenn nein, siehe Seite 3, Kombination **I**.

II Wenn ja, siehe Seite 3, Kombination **II**.

1-3 Befestigen Sie die Fernseher-Schienen

Tipps: Bei der Verwendung von M6(c) / M8(b /d) Schrauben, wenn dabei ein Abstandhalter (h) von 2,5mm gleichzeitig gebraucht wird, entfernen Sie dabei bitte den eingebauten Ring.

Schritt 2 Befestigen Sie die Wandplatte an der Wand Siehe Seite 4

Mitgelieferte Teile und Befestigungsmaterialien

Wandplatte zusammenbauen

Schritt 2A Die Montage von Holzbalkenwand Siehe Seite 4

⚠ Vorsicht: Verwenden Sie keinen Dübel, wenn Sie eine Wandplatte an einer Holzbalkenwand installieren!

⚠ Vorsicht: Alle vier Sechskant-Holzschrauben **01** müssen festgezogen werden, um ein ungewolltes Verrutschen der Wandplatte zu verhindern. Achten Sie darauf, dass die Wandplatte sicher an der Wand befestigt ist, bevor Sie mit dem nächsten Schritt anfangen. Fahren Sie bitte nach diesem Schritt mit 3. Schritt auf der Seite 6 fort.

Schritt 2B Die Montage von Massivbetonwand Siehe Seite 9

⚠ Vorsicht: Um mögliche Personen- oder Sachschäden zu vermeiden:

Alle vier Sechskant-Holzschrauben **01** müssen festgezogen werden, um ein ungewolltes Verrutschen der Wandplatte zu verhindern. Achten Sie darauf, dass die Wandplatte sicher an der Wand befestigt ist, bevor Sie mit dem nächsten Schritt anfangen.

Schritt 3 Hängen und befestigen Sie den Fernseher an der Wandplatte Siehe Seite 6

Bevor Sie den Fernseher an die Wandplatte hängen, führen Sie bitte eine Sicherheitsprüfung für die Montage der Wandplatte aus.

* Aus Sicherheitsgründen wird dieser Schritt am besten von zwei Personen gemeinsam ausgeführt.

Schritt 4 Funktionseinstellung Siehe Seite 7

Neigungseinstellung (+2°/-15°)

Lösen Sie den Griff um maximal 1/2 Umdrehung, stellen Sie den Fernseher auf die gewünschte Position ein und ziehen Sie dann den Griff wieder fest.

Einstellbarer Abstand zur Wand

Schritt 5 Nehmen Sie den Fernseher von der Wandhalterung ab Siehe Seite 8

Produktabmessung Siehe Seite 8

Avant l'installation, veuillez assurer que ce support est adapté à votre téléviseur ou pas !

1 Est-ce que la distance entre des trous de montage de votre téléviseur est plus de ou égale à 200x100mm/8x4" et moins de ou égale à 600x400mm/24x16" ?

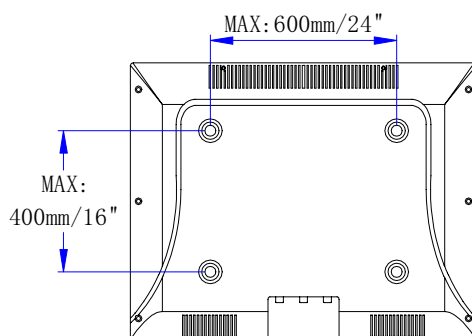

Oui - Parfait !

Non - Ce support ne vous convient pas !

2 Est-ce que votre téléviseur et des autres accessoires pèsent totalement moins de 54.5 KG (120 LBS) ?



Oui - Parfait !

Non - Ce support ne vous convient pas !

3 De quels genres matériaux le mur est fait ?

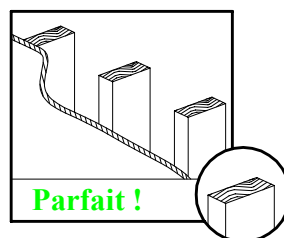
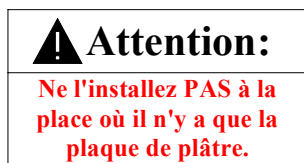

Cloison sèche avec montant en bois ?

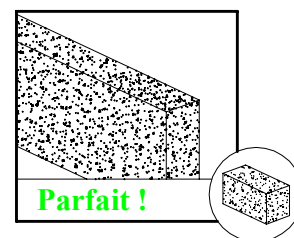

Mur en béton plein ?

4 Outils d'installation (Pas inclus)

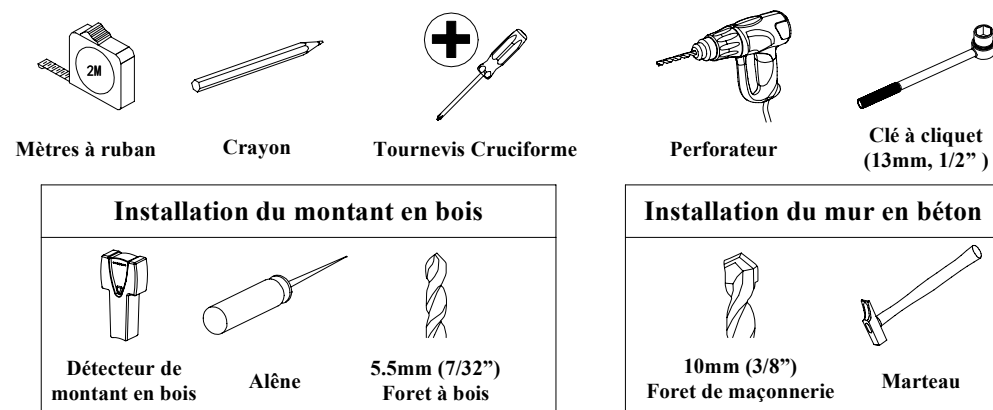

5 Consignes de sécurité

Avant l'installation, veuillez attentivement lire ce mode d'emploi.

- Ce produit s'applique au montant en bois, au mur en béton plein - Ne l'installez pas à la place où il n'y a que la plaque de plâtre.
- La force portante du mur doit atteindre au moins cinq fois du poids total de votre téléviseur et du support.
- N'utilisez pas ce produit pour des autres objectifs non désignés par Mounting Dream.
- L'installation incorrecte causera le dommage matériel ou la blessure corporelle. Mounting Dream n'assumera aucune responsabilité pour le dommage et la blessure causés par l'installation incorrecte ou l'utilisation inadéquate.

Instruction d'installation

⚠ AVERTISSEMENT : Ce produit contient des petites pièces, en cas d'ingestion, des risques de suffocation y arrivera. Avant l'installation, veuillez vérifier que tous les accessoires et toutes les pièces sont complets et non défectueux.

ATTENTION : Les pièces fournies ne seront pas toutes utilisées durant l'installation.

Étape 1 Installer des barres verticales sur votre téléviseur Voir à la page 2

Pièces et accessoires

1-1 Choisir des vis de téléviseur

1-2 Entretoises sont nécessaires ?

I Non, voir à la page 3, combinaison **I**.

II Oui, voir à la page 3, combinaison **II**.

1-3 Assembler des barres verticales

Remarque : Quand vous choisissez la vis M6(c) / M8(b/d) et l'entretoise (h) de 2.5mm est nécessaire, veuillez enlever la cerce interne.

Étape 2 Installer la plaque murale au mur Voir à la page 4

Pièces et accessoires

Assemblez la plaque murale

Étape 2A Installation du montant en bois Voir à la page 4

⚠ Attention : Pour éviter d'éventuelles blessures corporelles ou des dommages matériels:

Tous les quatre boulons tire-fond **01** doivent être fermement serrés pour éviter le mouvement non souhaité de la plaque murale. Veuillez vérifier que la plaque murale est fixée sur le mur avant de passer à l'étape suivante. Après avoir fini cette étape, allez directement à la page 6 et continuez l'étape 3.

Étape 2B Installation du mur en béton plein Voir à la page 9

⚠ Attention : Pour éviter d'éventuelles blessures corporelles ou des dommages matériels:

Tous les quatre boulons tire-fond **01** doivent être fermement serrés pour éviter le mouvement non souhaité de la plaque murale. Veuillez vérifier que la plaque murale est fixée sur le mur avant de passer à l'étape suivante.

Étape 3 Suspendre et fixer votre téléviseur sur la plaque murale Voir à la page 6

Avant de suspendre votre téléviseur sur la plaque murale, veuillez tester la fiabilité de l'installation de la plaque murale.

* Compte tenu de la sécurité, deux personnes sont nécessaires pour l'installation.

Étape 4 Ajustement de fonction Voir à la page 7

L'ajustement de l'angle d'inclinaison (+2°/-15°)







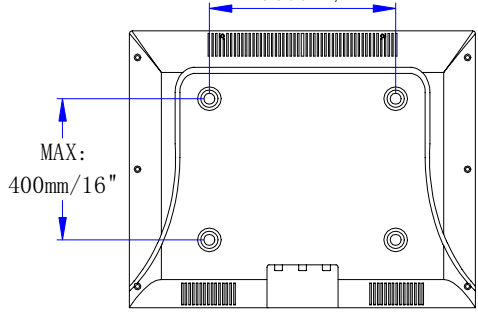

Ajustez le téléviseur à l'angle souhaité, puis serrez 2 vis.

Distance réglable du mur.

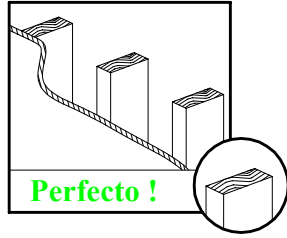
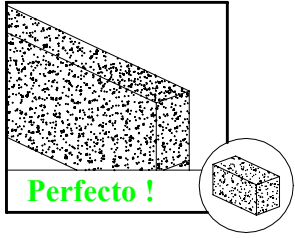
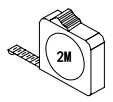
Étape 5 Démonter votre téléviseur de la plaque murale Voir à la page 8

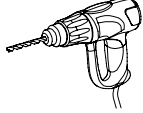
Dimensions de produit Voir à la page 8

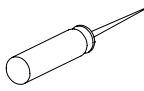
Antes de comenzar a instalar este soporte mural para tv , favor confirme si es el adecuado para su televisor!

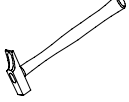
<p>1 Los orificios posteriores de su televisor tienen una distancia mayor o igual a 200x100mm/8x4" y menor o igual a 600x400mm/24x16"?</p>	 <p>Si - Es el adecuado! No - Este soporte no es el adecuado!</p>
<p>2 El peso de su televisor y los demás accesorios en total es menor a 54.5 KG (120 LBS)?</p>	 <p>Si - Es el adecuado! No - Este soporte no es el adecuado!</p>
<p>3 La pared de que material esta construida?</p>	<div style="display: flex; justify-content: space-around;"> <div data-bbox="502 963 805 1131"> <p>⚠ Atención: En paredes de yeso o derivados no se debe instalar.</p> </div> <div data-bbox="837 940 1125 1176">  <p>Instalar en paredes con pilares de madera?</p> </div> <div data-bbox="1173 940 1468 1176">  <p>Instalar en paredes de hormigón sólido?</p> </div> </div>
<p>4 Herramientas necesarias para su instalación (No incluido)</p>	<div style="display: flex; justify-content: space-around; text-align: center;"> <div data-bbox="510 1299 654 1444">  Cinta Métrica </div> <div data-bbox="678 1299 821 1444">  Lápiz </div> <div data-bbox="845 1299 1085 1444">  Destornillador de Cruz </div> <div data-bbox="1133 1299 1308 1444">  Taladro Eléctrico </div> <div data-bbox="1340 1299 1508 1444">  Juego de llaves (13mm, 1/2") </div> </div> <div style="display: flex; justify-content: space-around; margin-top: 10px;"> <div data-bbox="534 1467 1053 1702"> <p style="text-align: center;">Instalación en pared con pilares de madera</p> <div style="display: flex; justify-content: space-around;"> <div data-bbox="558 1534 678 1691">  Detector de Madera </div> <div data-bbox="694 1534 837 1691">  Punzón </div> <div data-bbox="853 1534 1029 1691">  5.5mm (7/32") Broca para Madera </div> </div> </div> <div data-bbox="1117 1467 1500 1702"> <p style="text-align: center;">Instalación en pared de hormigón</p> <div style="display: flex; justify-content: space-around;"> <div data-bbox="1149 1534 1324 1691">  10mm (3/8") Broca de Impacto </div> <div data-bbox="1348 1534 1492 1691">  Martillo </div> </div> </div> </div>
<p>5 Advertencias de seguridad</p>	<p>Antes de la instalación favor de leer en detalle el manual de instrucciones.</p> <ul style="list-style-type: none"> • Este producto es apto para paredes con pilares de madera, y muro de hormigón sólido - No instalar en paredes de solo yeso. • La capacidad de soporte de la pared debe ser cinco veces más que el peso total del televisor y el soporte. • Favor NO utilizar el producto de Mounting Dream para otros usos no asignados. • La instalación incorrecta puede producir daños al producto o lesiones al usuario. Cualquier pérdida o daño debido por la mala instalación o uso indebido, Mounting Dream no asume ninguna responsabilidad.

Instrucciones paso a paso de su instalación

⚠ Advertencia: Este producto contiene piezas pequeñas, si por error se ingiere, puede provocar peligro de asfixia. Antes de comenzar la instalación, favor compruebe que todos los accesorios y piezas de repuesto estén completas y sin daño alguno.

Atención: No todas las piezas se utilizarán.

Paso 1 Instalar las varillas del soportes al televisor Ver página 2

Accesorios y piezas

1-1 Elegir los tornillos para el televisor

1-2 Necesito espaciadores?

I No necesito, favor ver la combinación **I** en la página 3.

II Necesito, favor ver la combinación **II** en la página 3.

1-3 Instalar las varillas del soporte

Tips: Si necesita espaciadores de 2,5mm (h) combinados con tornillos de M6(c) / M8(b / d), favor retirar la argolla/anillo.

Paso 2 Instalar la placa mural Ver página 4

Accesorios y piezas

Montaje de placa de pared

Paso 2A Instalación en pared con pilares de madera Ver página 4

⚠ Atención: Al momento de instalar el panel en la pared con pilares de madera, favor no usar los tacos/tarugos para la pared de hormigón!

⚠ Atención: Los cuatro tornillos **01** de cabeza hexagonal deben apretarse firmemente, para evitar que la placa mural en la pared se mueva. Favor de asegurarse que quede firmemente estable en la pared para poder continuar con los siguientes pasos de la instalación. Luego de terminar este paso favor continuar con el paso 3 en la página 6.

Paso 2B Instalación en pared de hormigón sólido Ver página 9

⚠ Atención: Los cuatro tornillos **01** de cabeza hexagonal deben apretarse firmemente, para evitar que la placa mural en la pared se mueva. Favor de asegurarse que quede firmemente estable en la pared para poder continuar con los siguientes pasos de su instalación.

Paso 3 Colgar y sujetar del televisor a la placa mural Ver página 6

Antes de colgar el televisor en la placa mural, favor realizar una prueba de confiabilidad a la instalación.

* Por razones de seguridad, para concluir este paso es mejor hacerlo en compañía de otra persona.

Paso 4 Funciones de regulación Ver página 7

Regulación del ángulo de inclinación (+2°/-15°)

Afloje las 2 manijas, ajuste su televisor al ángulo deseado, y luego vuelva a apretar las manijas.

Distancia ajustable de la pared

Paso 5 Quitar el televisor del soporte mural Ver página 8

Dimensiones del producto Ver página 8

Prima di iniziare l'installazione, per prima cosa conferma se questo Supporto è ideale per la vostra TV!

1 La distanza dei fori di installazione TV sono superiore/uguale a 200x100mm/8x4" e inferiore /uguale a 600x400mm/24x16"?

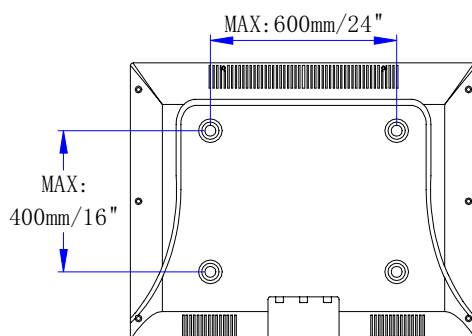

Sì - Ideale!

No - Questo supporto non va!

2 Il tuo televisore (inclusi accessori) pesa totalmente inferiore a 54.5 KG (120 LBS)?



Sì - Ideale!

No - Questo supporto non va!

3 Di che materiale è fatto il muro?

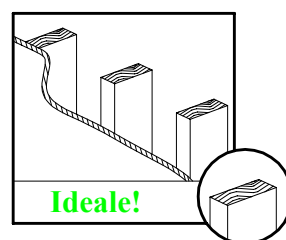

Muro secco con i pilastri in legno?

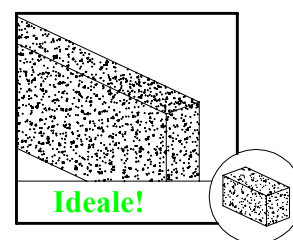

Muro in calcestruzzo solido ?

4 Utensili per installazione (Non incluso)

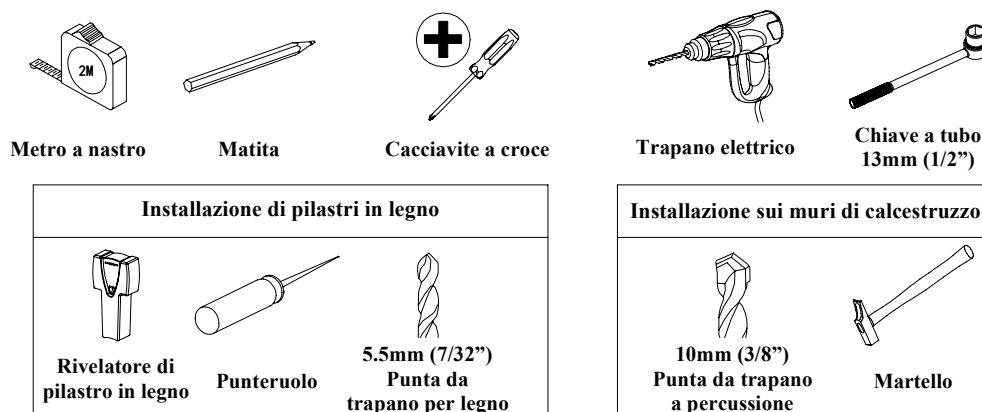

5 Cautele per sicurezza

Leggi attentamente le istruzioni prima di installazione.

- Questo prodotto è progettato per pilastri in legno e muri in calcestruzzo solido - NON installarlo in soli cartongessi.
- Il muro deve essere capace di portare almeno cinque volte il peso totale del televisore e del supporto.
- Non applicare questo prodotto ad altri scopi non indicati da Mounting Dream.
- L'installazione errata potrebbe causare danni al prodotto o lesioni personali. Mounting Dream non si assume alcuna responsabilità per danni o lesioni causate da installazione impropria o uso improprio.

Istruzioni di installazione

⚠ Avvertenza: Questo prodotto contiene piccoli articoli che potrebbe causare il pericolo di soffocamento se ingoiati. Prima di iniziare l'installazione, controlla se tutti gli accessori e parti siano inclusi e non danneggiati.

Nota: Non verranno utilizzati tutte le parti incluse.

Passo 1 Installa barre verticali al televisore Vedi pagina 2

Accessori e parti

1-1 Seleziona viti TV

1-2 Si ha bisogno di pilastri con guarnizione?

I No, vedi la combinazione **I** nella pagina 3.

II Sì, vedi la combinazione **II** nella pagina 3.

1-3 Installazione di barre verticali

Suggerimento: se è necessario combinare il pilastro con guarnizione 2,5mm (h) con la vite M6(c) / M8(b/ d), rimuovi l'anello interno.

Passo 2 Installa la piastra a muro sul muro Vedi pagina 4

Accessori e parti

Assemblare la piastra a muro

Passo 2A Installazione sul muro con i pilastri in legno Vedi pagina 4

⚠ Cautela: Per evitare potenziali lesioni personali o danni alla proprietà:

Le quattro viti **01** per Legno a testa esagonale devono essere avvitate bene in modo da evitare movimenti indesiderati della piastra a muro. Assicura che la piastra a muro sia ben fissata sul muro prima di eseguire il prossimo passo. Dopo finire questo passo, va direttamente alla pagina 6 per il passo 3.

Passo 2B Installazione sul muro in calcestruzzo Vedi pagina 9

⚠ Cautela: Per evitare potenziali lesioni personali o danni alla proprietà:

Le quattro viti **01** per Legno a testa esagonale devono essere avvitate bene in modo da evitare movimenti indesiderati della piastra a muro. Assicura che la piastra a muro sia ben fissata sul muro prima di eseguire il prossimo passo.

Passo 3 Appendi e fissa la TV alla piastra a muro Vedi pagina 6

Prima di appendere la TV alla piastra a muro, esegui un test di affidabilità dell'installazione della piastra a muro.

* Per la sicurezza, è meglio eseguire questo passo da due persone.

Passo 4 Regolazioni di funzione Vedi pagina 7

Regolazione dell'angolo di inclinazione (+2°/-15°)

Tirare la TV all'angolazione desiderata, quindi fissare 2 Maniglie.

Distanza regolabile dal muro

Passo 5 Togli la TV dalla piastra a muro Vedi pagina 8

Dimensioni del prodotto Vedi pagina 8