

Mounting Dream

MD2285-XL INSTALLATION INSTRUCTION

Für die Installationsanweisungen auf Deutsch, siehe Seite 10~11.

Pour l'instruction en Français, veuillez vous reporter à la page 12~13.

Para las instrucciones de la instalación en Español, favor vea la página 14~15.

Per le Istruzioni in Italiano, vedi pagina 16~17.

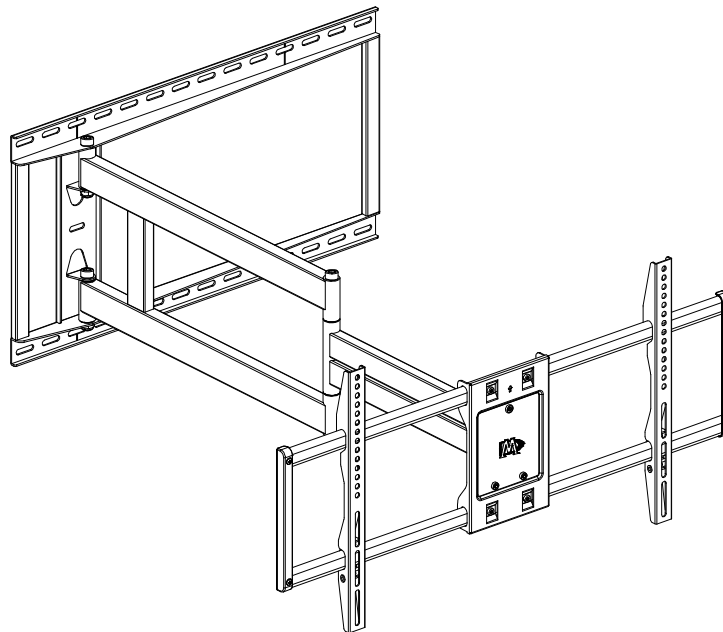

x3

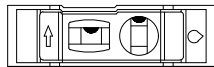

x1

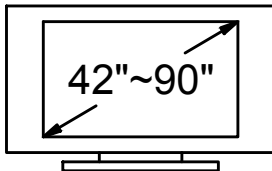





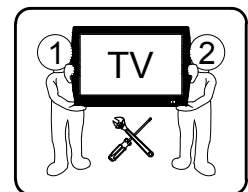

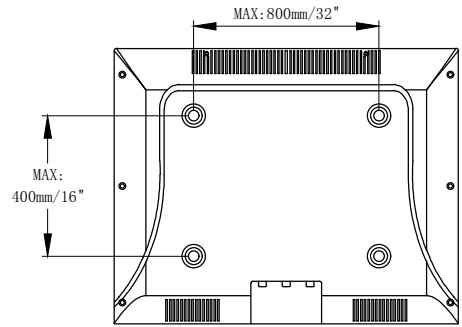

Max: 800x400mm/32x16"

Min: 200x100mm/8x4"

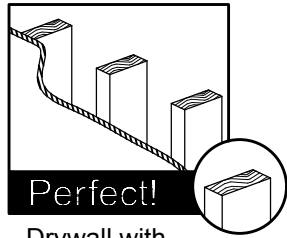
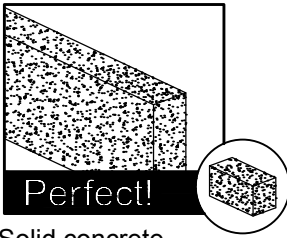
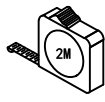

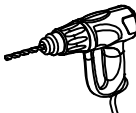
(B3)

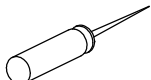
Before getting started, let's make sure this mount is perfect for you!

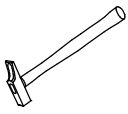
<p>1 Is your TV VESA equal to/greater than 200x100mm/8x4" and equal to/less than 800x400mm/32x16"?</p>	 <p>Yes --- Perfect!</p> <p>No --- This mount is NOT compatible.</p>
<p>2 Does your TV (including accessories) weigh less than 150 LBS (68 kg)?</p>	 <p>Yes --- Perfect!</p> <p>No --- This mount is NOT compatible.</p>
<p>3 What is your wall made of?</p>	<div style="display: flex; justify-content: space-around; align-items: flex-start;"> <div style="text-align: center;">  </div> <div style="text-align: center;">  <p>Perfect!</p> <p>Drywall with wood studs?</p> </div> <div style="text-align: center;">  <p>Perfect!</p> <p>Solid concrete wall?</p> </div> </div>
<p>4 Installation Tools (Not Included)</p>	<div style="display: flex; justify-content: space-around; text-align: center;"> <div> Band Tape</div> <div> Pencil</div> <div> Screwdriver</div> <div> Electrodrill</div> <div> Socket Wrench 1/2" (13mm)</div> </div> <div style="display: flex; justify-content: space-around; margin-top: 10px;"> <div style="border: 1px solid black; padding: 5px; width: 30%;"> <p style="writing-mode: vertical-rl; transform: rotate(180deg);">Wood Stud Install</p> <div style="display: flex; justify-content: space-around;"> <div style="text-align: center;"> Stud Finder</div> <div style="text-align: center;"> Awl</div> <div style="text-align: center;"> 7/32" (5.5mm) Wood Drill Bit</div> </div> </div> <div style="border: 1px solid black; padding: 5px; width: 30%;"> <p style="writing-mode: vertical-rl; transform: rotate(180deg);">Concrete Install</p> <div style="display: flex; justify-content: space-around;"> <div style="text-align: center;"> 3/8" (10mm) Masonry Drill Bit</div> <div style="text-align: center;"> Hammer</div> </div> </div> </div>
<p>5 Safety Caution</p>	<p>Please read this instruction carefully before installation.</p> <ul style="list-style-type: none"> • This product is designed for use in wood stud and solid concrete wall. <ul style="list-style-type: none"> - DO NOT install into drywall alone. • The wall must be capable of supporting five times the weight of the TV and mount combined. • Do not apply this product to any purpose not indicated by Mounting Dream. • Incorrect installation may result in product damage or body injury. Mounting Dream shall bear no responsibility for any damage or injury resulted from incorrect installation, incorrect assembly or misuse.

STEP 1 Attach Brackets to TV

Parts and Hardware

⚠ WARNING: This product contains small items that could be a choking hazard if swallowed. Before starting assembly, verify all parts are included and undamaged.

NOTE: Not all hardware included will be used.

TV Brackets

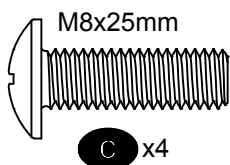
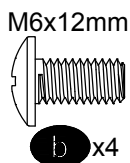
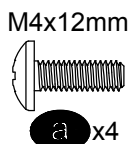
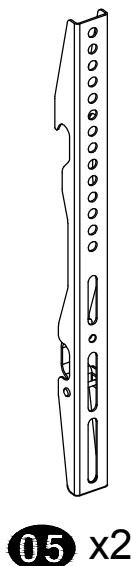

TV Screws

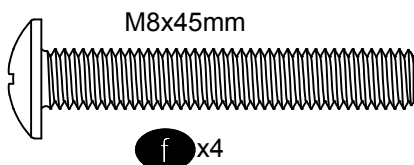
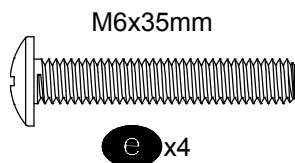
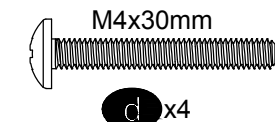

Spacers

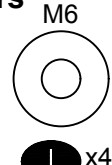
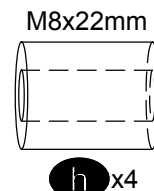
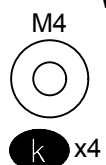
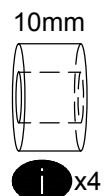
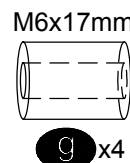

Washers

1-1 Select TV Screws

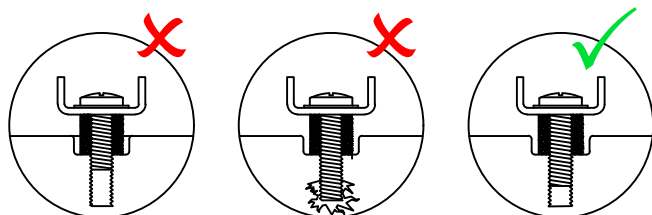
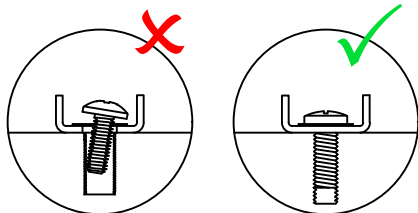
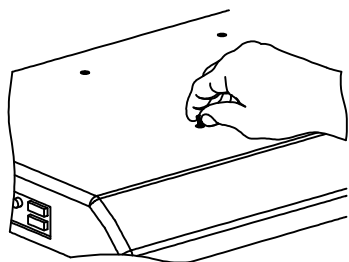

1-2 Need Spacer?

I No, go to PAGE 3 **I** for detailed combination.

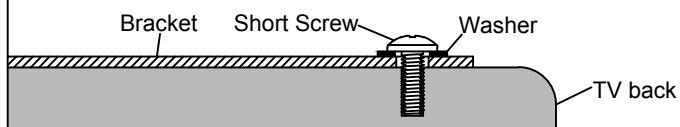

II Yes, go to PAGE 3 **II** for detailed combination.

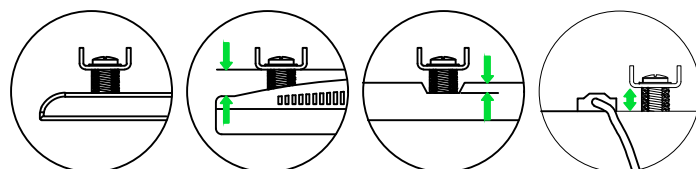
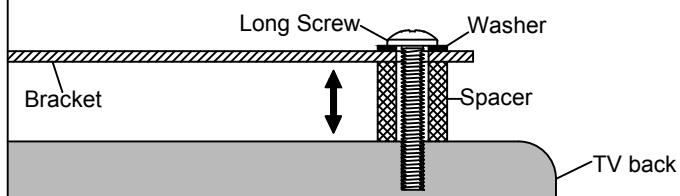

1-3 Attach the TV Brackets

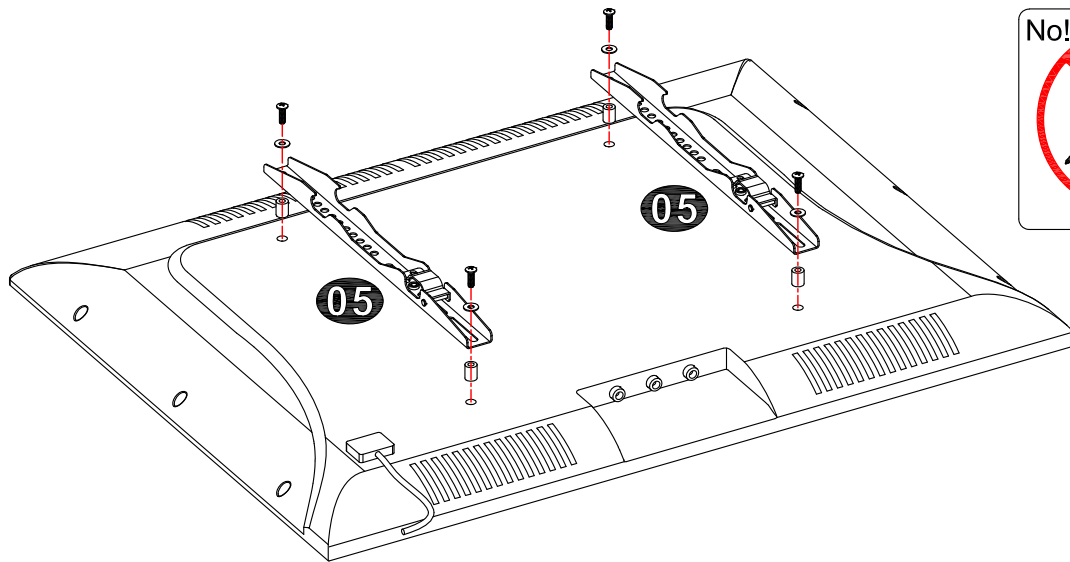

I Screw and washer

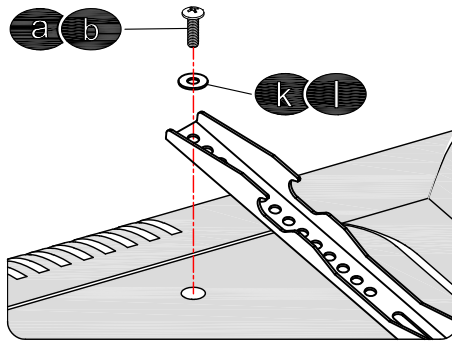

II Spacer(s), screw and washer

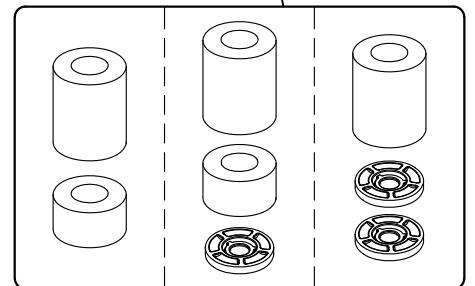
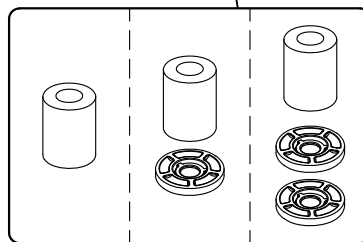
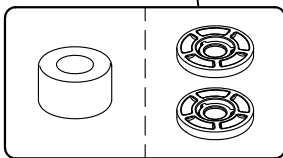
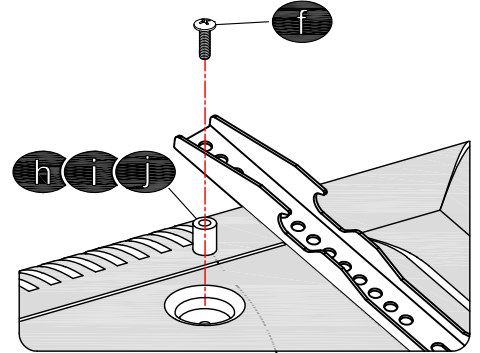
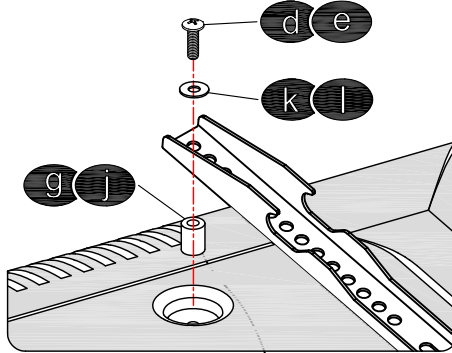
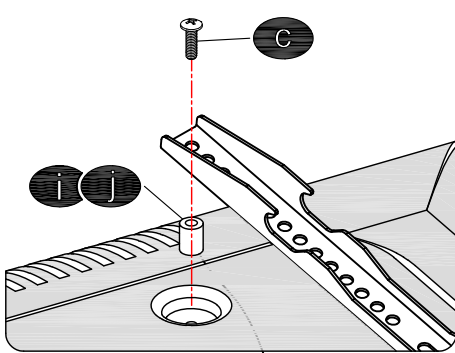

Tips: If you need to combine M6(e) or M8(c/f) screw with 2.5mm spacer(j), you have to remove the inner circle.

STEP 2 Attach Wall Plate to Wall

 For wood stud installation, follow STEP 2A

 For concrete installation, follow STEP 2B on PAGE 6

Parts and Hardware

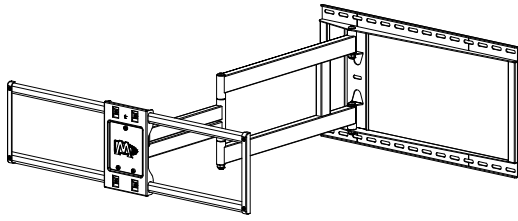

Wall Plate Unit **04** x1

Mounting Template x1

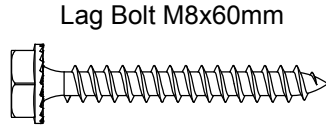
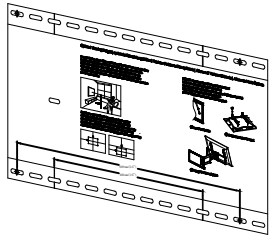

01 x5



Allen Key

02 x1

M6x15mm Bolt

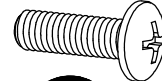

03 x2

Concrete wall anchor (NOT INCLUDED)

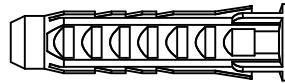

Concrete Wall Anchor
5pcs

STEP 2A Wood Stud Installation

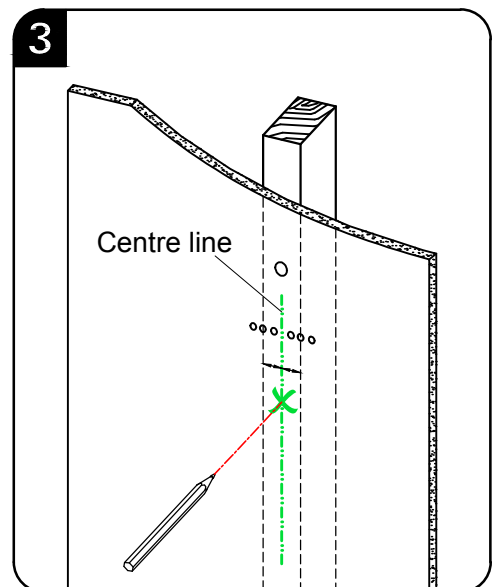
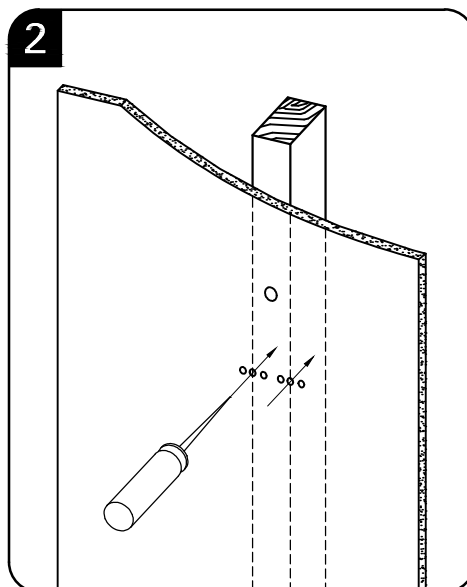
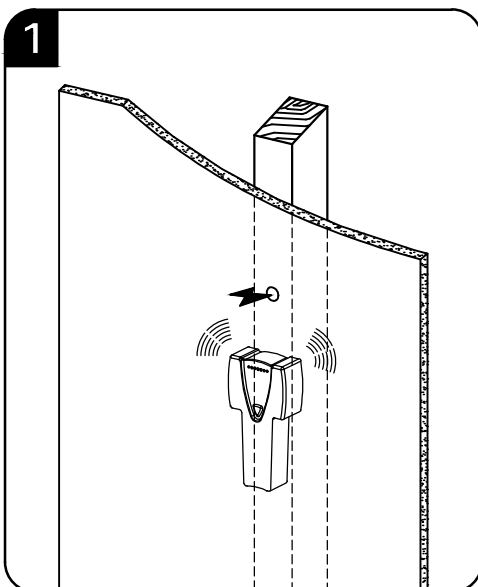
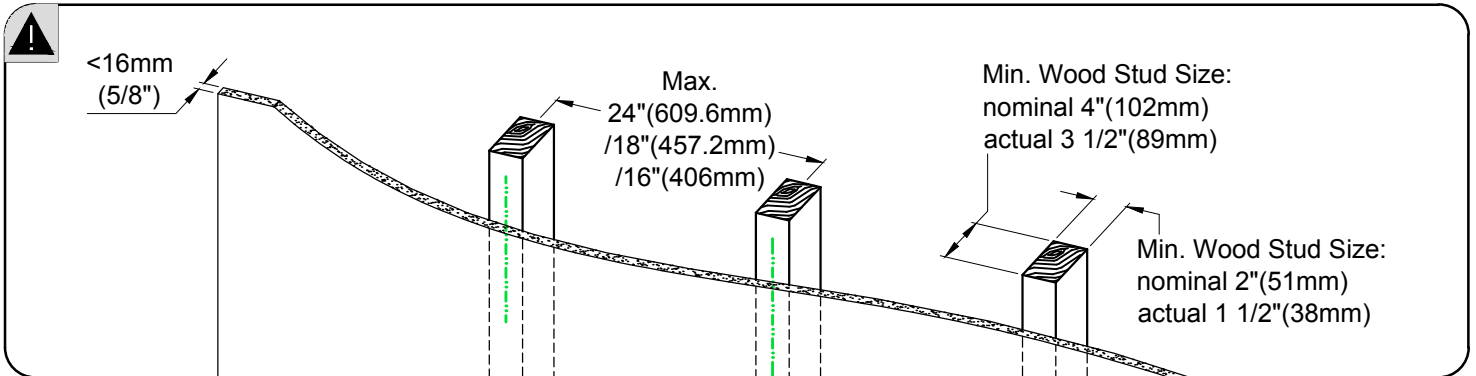

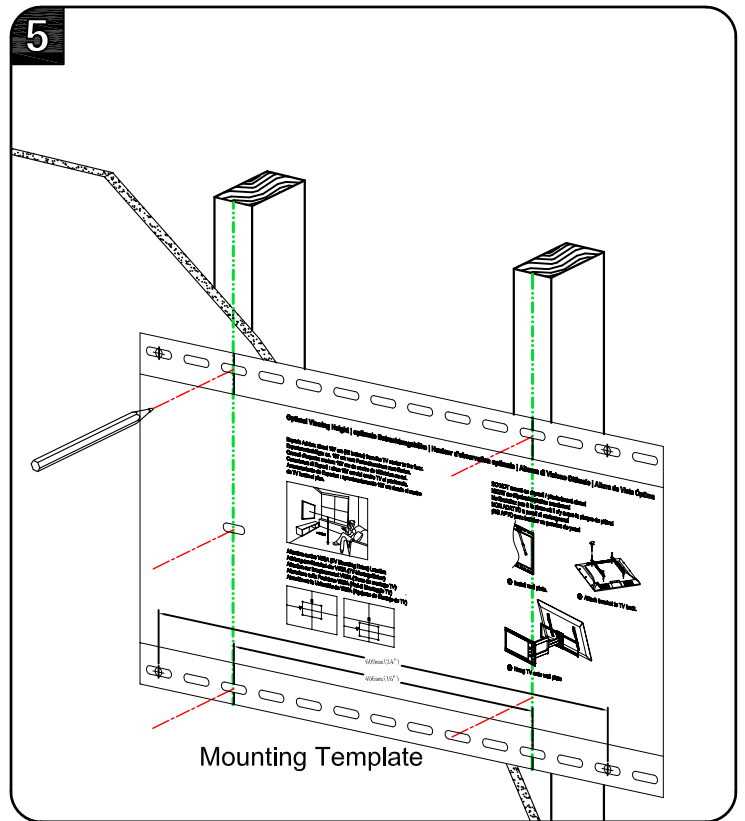
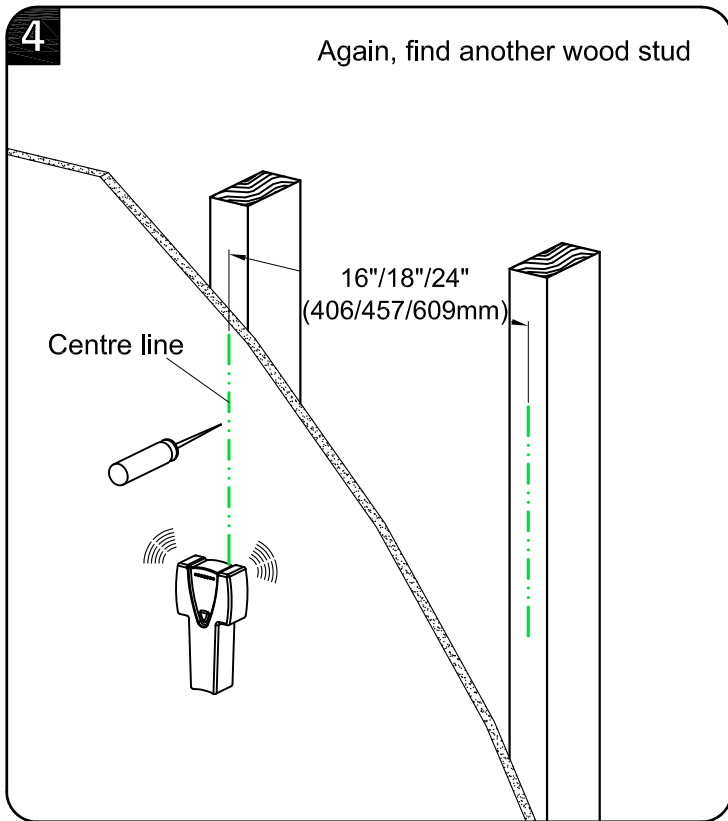

⚠ CAUTION: To avoid potential personal injury or property damage:
 All 5 lag bolts **01** MUST BE firmly tightened to prevent unwanted movement of the wall plate assembly. Ensure the wall plate assembly is securely fastened to the wall before continuing on to the next step.
 To prevent the TV falling down, the Bolt Head Must Keep UP at this step!!

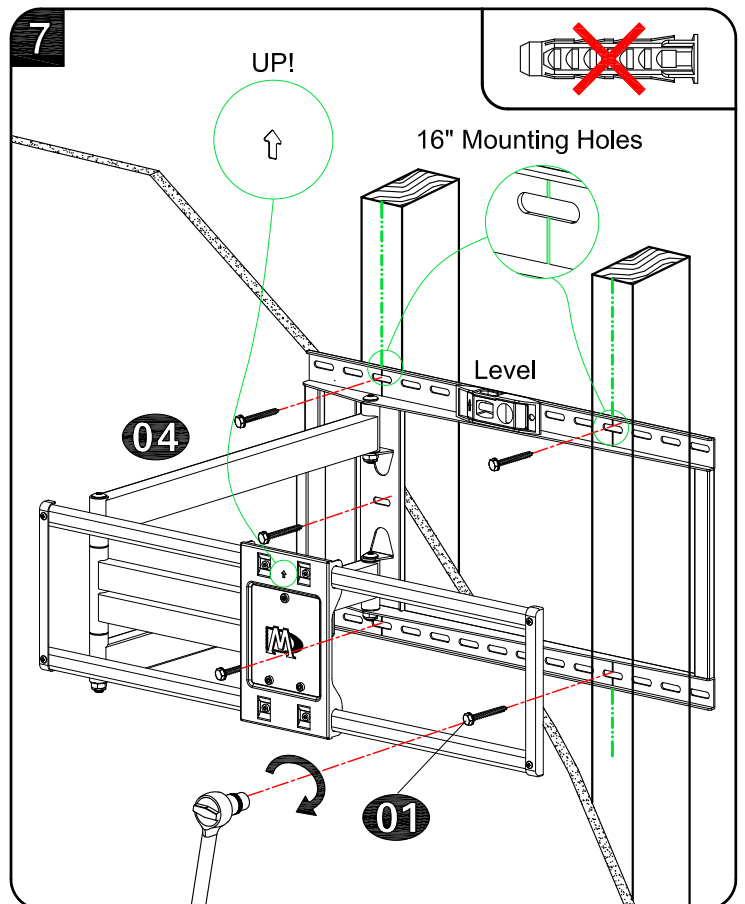
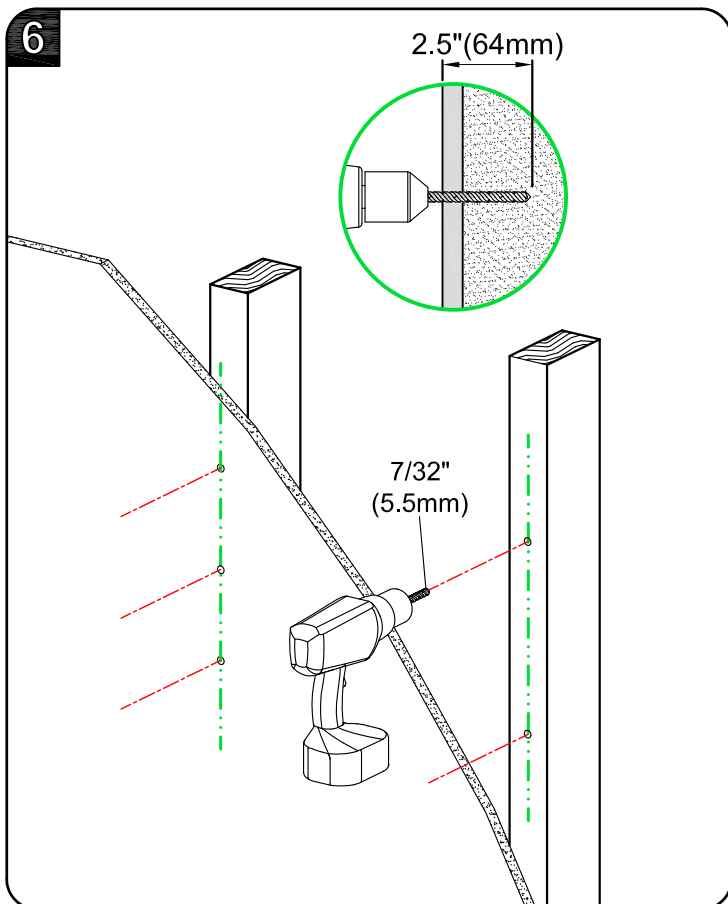

Go to Step 3 on PAGE 7.

STEP 2B

Solid Concrete Wall Installation

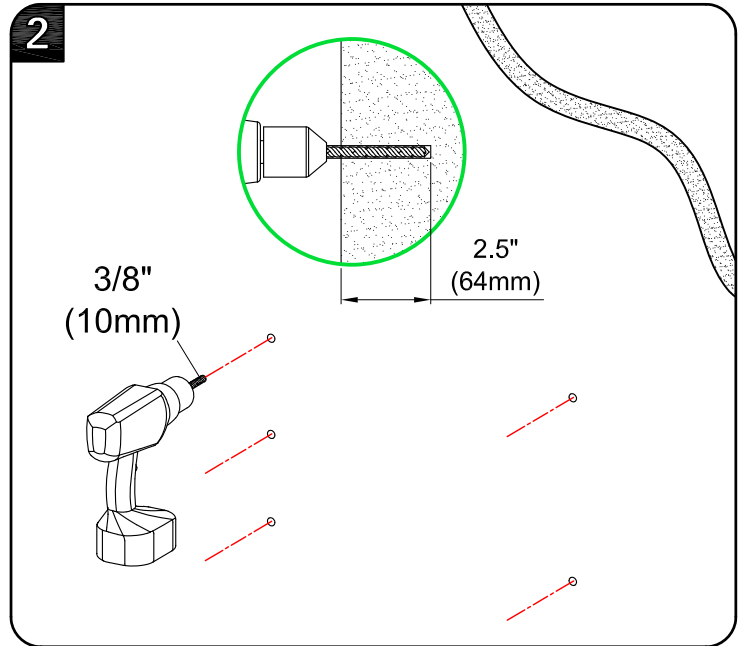
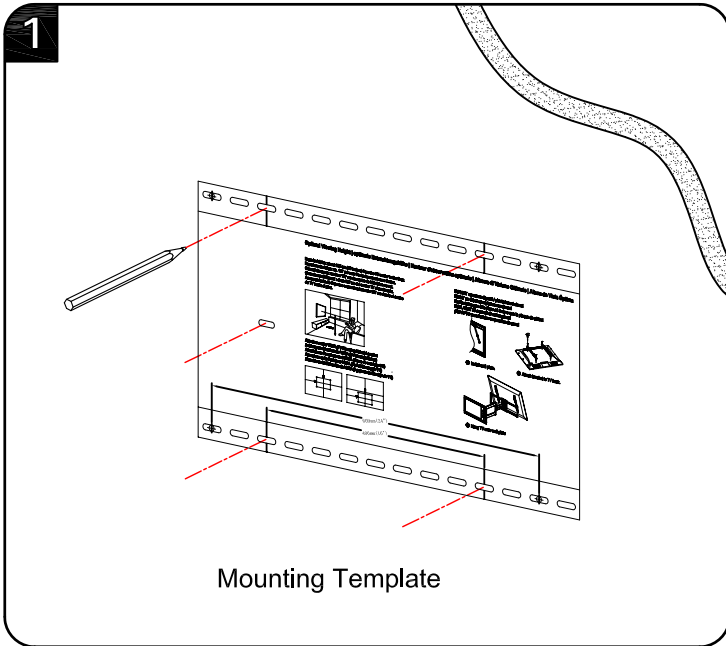
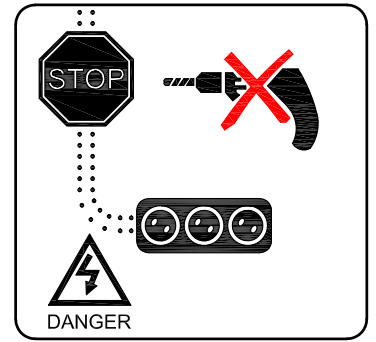
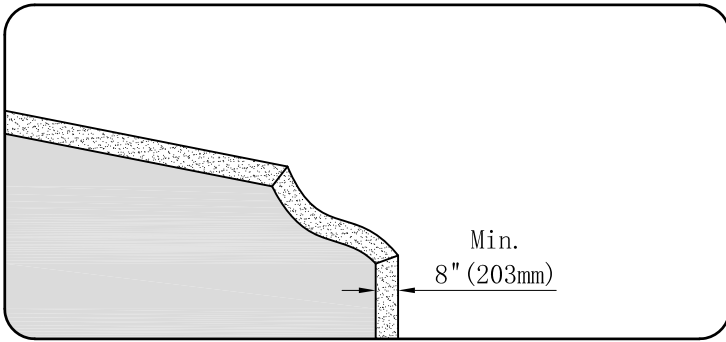

⚠ CAUTION: To avoid potential personal injury or property damage:
All 5 lag bolts **01** MUST BE firmly tightened to prevent unwanted movement of the wall plate assembly. Ensure the wall plate assembly is securely fastened to the wall before continuing on to the next step.
To prevent the TV falling down, the Bolt Head Must Keep UP at this step!!

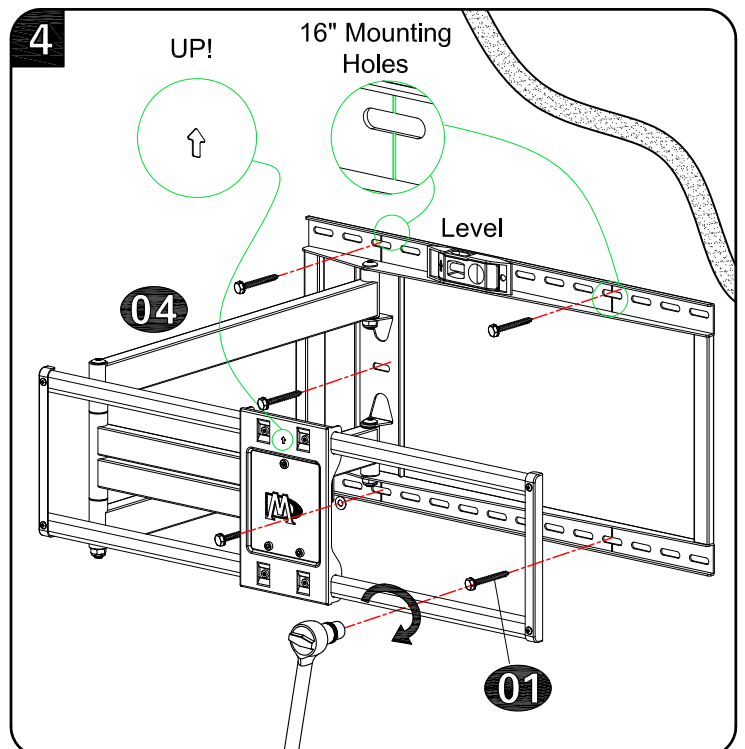
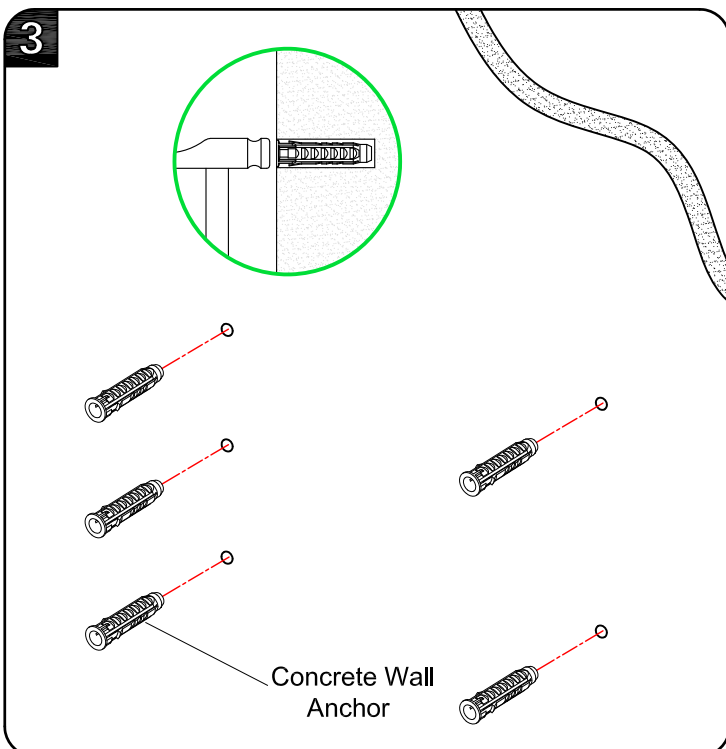

STEP 3 Hang and Secure TV to Wall Plate

Before hanging TV, please conduct "wall plate installation integrity test" first.

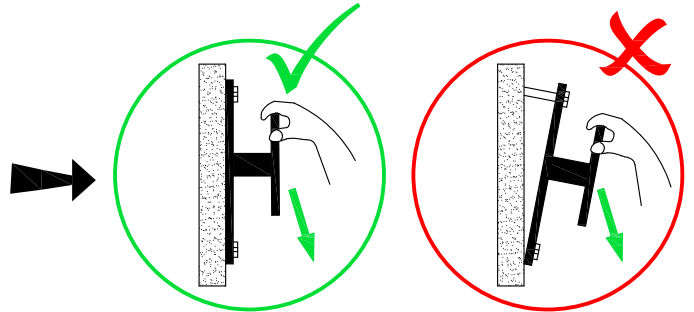
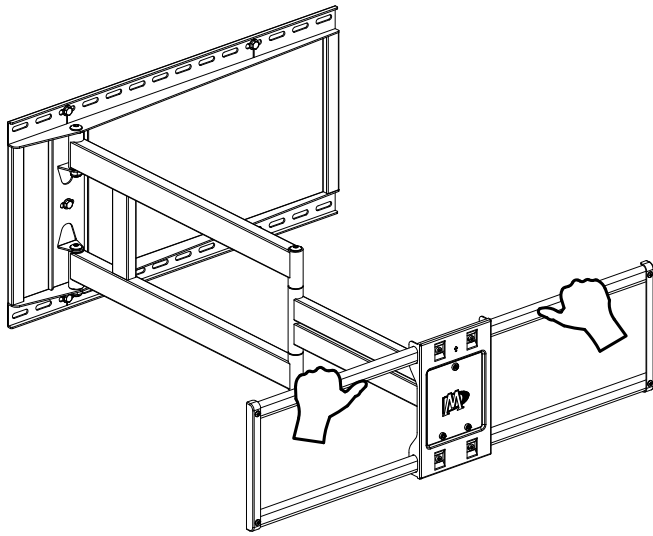

150 LBS (68 kg)

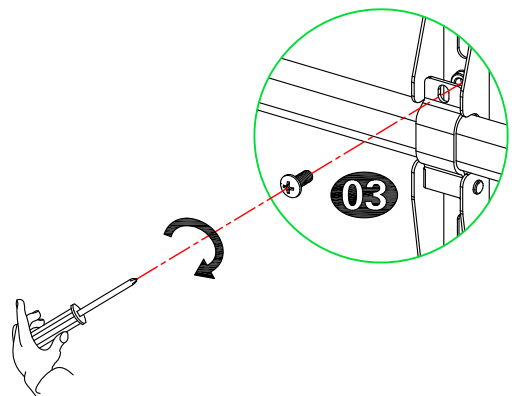
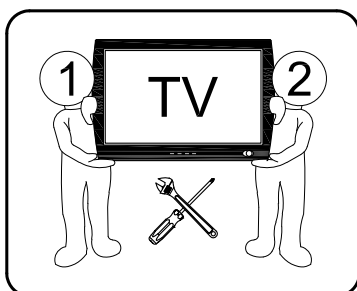
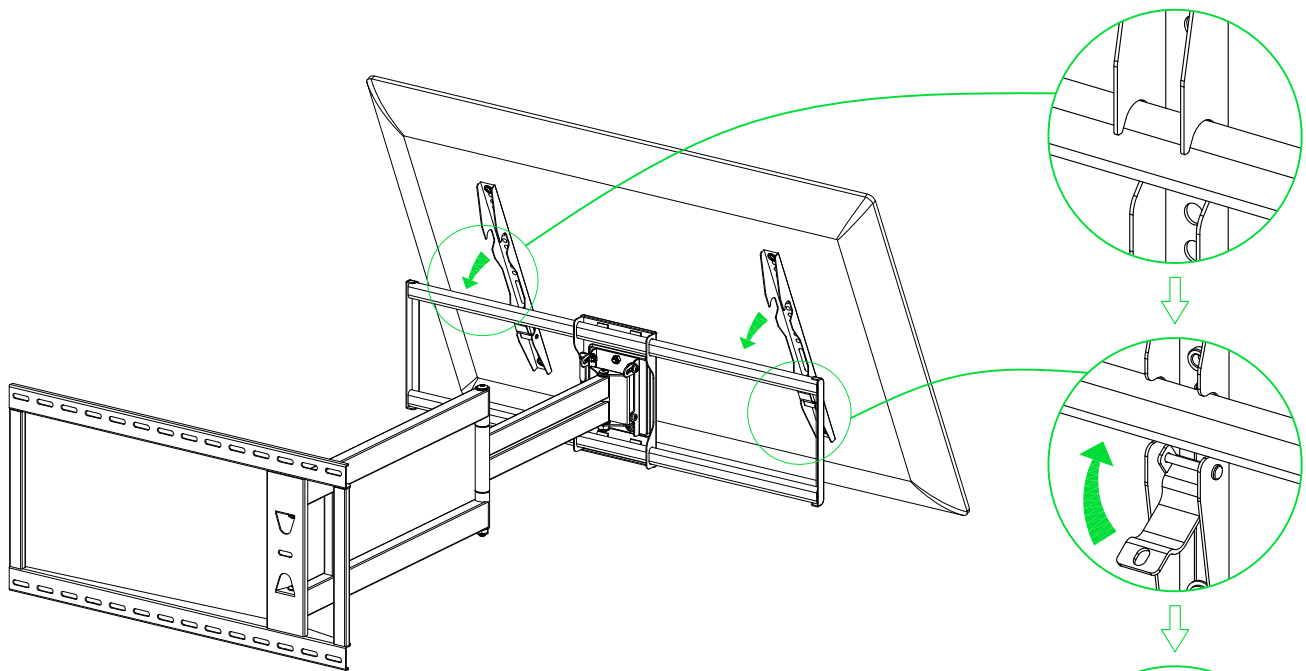

STEP 4 Adjustments

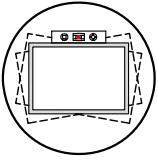

4-1 TV leveling adjustment ($\pm 3^\circ$):

Loosen 2 leveling bolts on the rear of TV plate by maximum 2 turns, adjust to level, and retighten to secure.

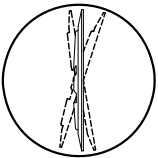
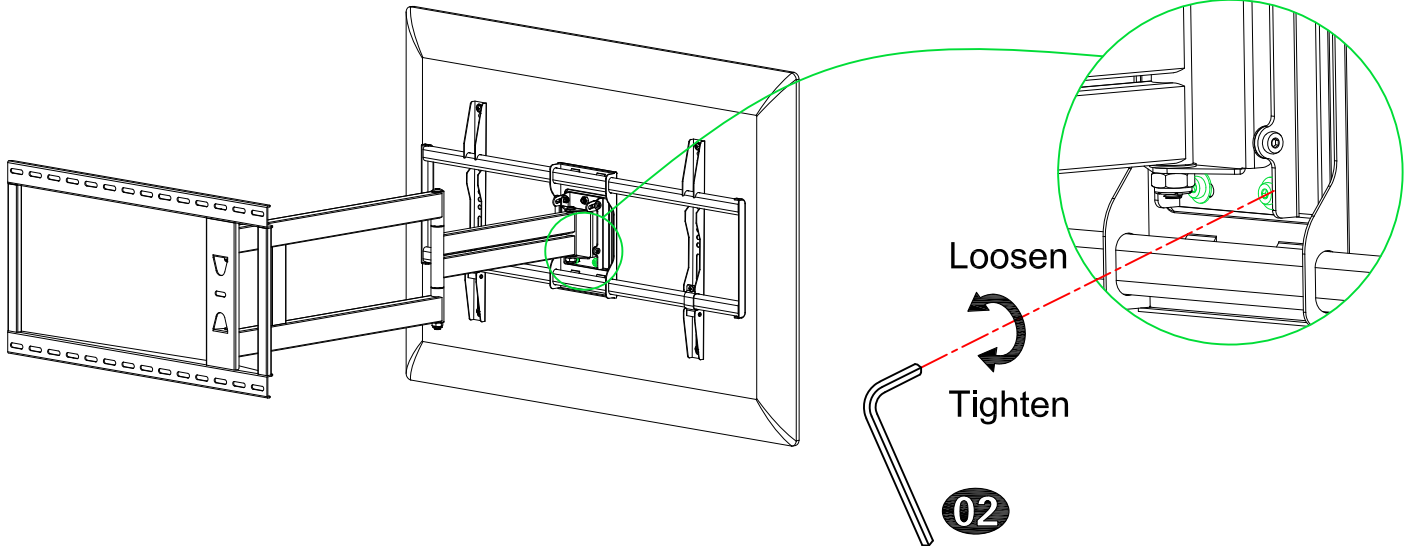

4-2 Tilting angle adjustment ($+5^\circ/-12^\circ$):

Loosen handle and tilting bolt, adjust TV to your desired position, then tighten handle and tilting bolt.

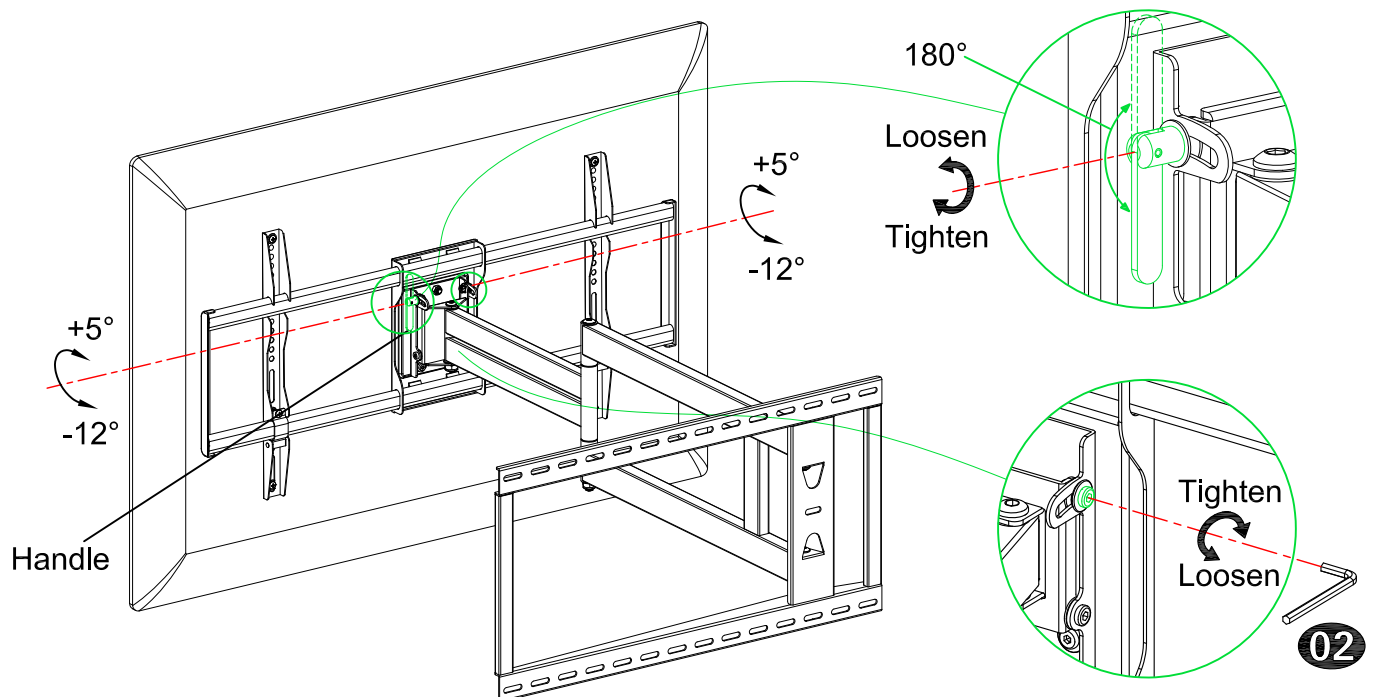

Product dimensions:

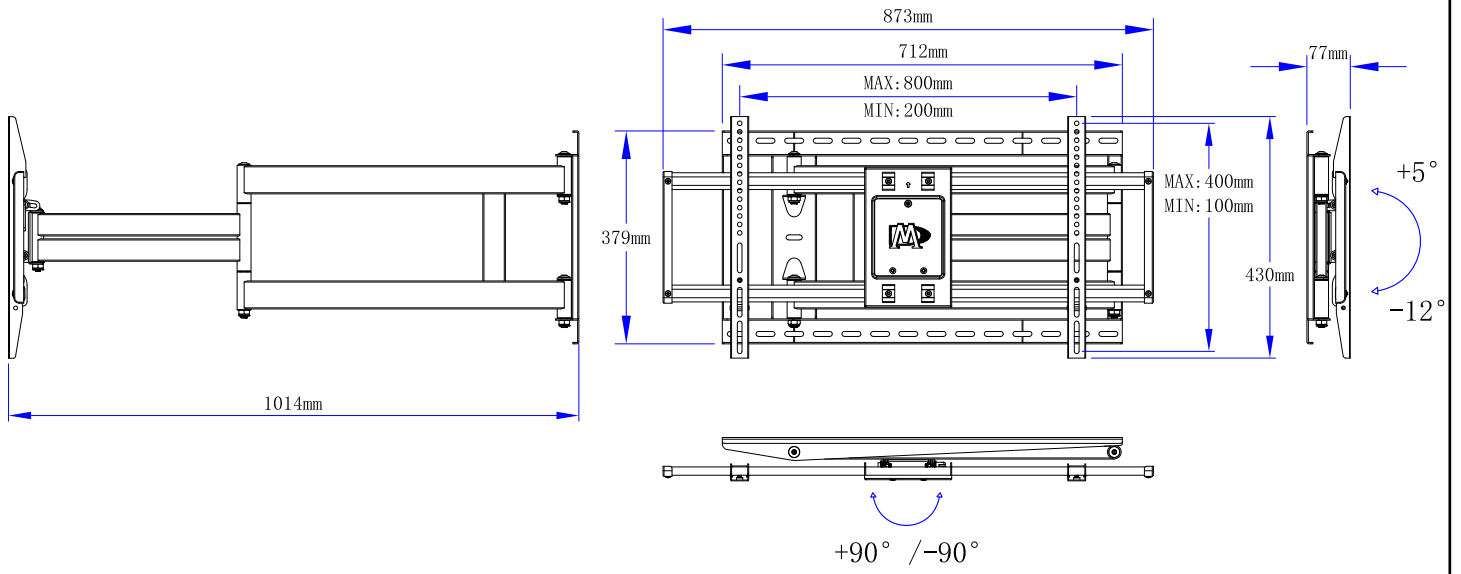

Vor der Installation bestätigen Sie bitte zuerst, ob diese Halterung für Ihr Fernsehapparat geeignet ist!

1 Ist der Abstand der Montagelöcher von Ihrem Fernsehapparat zwischen 200x100mm/8x4" und 800x400mm/32x16"?

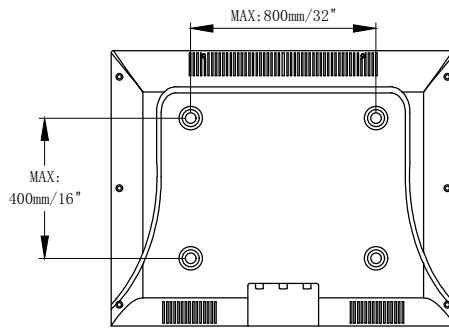

Ja - Perfekt!

Nein - Diese Halterung ist nicht geeignet!

2 Wiegt Ihr Fernsehapparat (inkl. Zubehör) weniger als 68 kg (150 LBS)?



Ja - Perfekt!

Nein - Diese Halterung ist nicht geeignet!

3 Woraus besteht Ihre Wand?

⚠ Vorsicht:
NICHT an einer reinen Gipskartonwand anbringen.

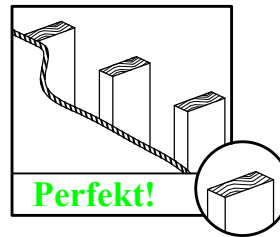

Gipskartonwand mit Holzbalken?

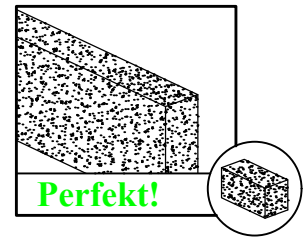

Massivbetonwand?

4 Werkzeuge für Installation (Nicht enthalten)

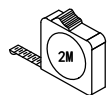

Bandmaß



Bleistift

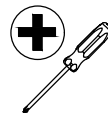

Kreuzschlitzschraubendreher

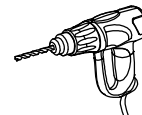

Elektrobohrer

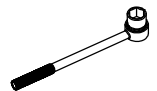

Steckschlüssel (13mm, 1/2")

Montage von Holzbalkenwand		
Balkensucher	Ahle	5,5mm (7/32") Bohreinsatz für Holz

Montage von Betonwand	
10mm (3/8") Bohreinsatz für Stein	Hammer

5 Sicherheitshinweise

Bitte lesen Sie die Anweisungen sorgfältig vor der Installation durch.

- Dieses Produkt ist für die Installation an Wänden mit Holzträgern und Massivbetonwand - NICHT an einer reinen Gipskartonwand montieren.
- Die Wand muss das Fünffache des Gesamtgewichts des Fernsehapparats und der Halterung tragen können.
- Verwenden Sie dieses Produkt nicht für einen anderen Zweck als speziell von Mounting Dream angegeben.
- Unsachgemäße Montage dieses Produkts kann zu Verletzungen und zu den Beschädigungen an Ihrem Gerät führen. Mounting Dream haftet nicht für Schäden oder Verletzungen, die durch unsachgemäße Montage, unsachgemäßen Zusammenbau oder unsachgemäße Verwendung verursacht wurden.

Installationsanweisungen

⚠️ Warnung: Dieses Produkt enthält kleine Teile, die beim Verschlucken zur Erstickungsgefahr führen können. Bevor Sie mit der Installation beginnen, überprüfen Sie bitte, ob alle Zubehörteile und Ersatzteile vollständig und unbeschädigt sind.

Hinweis: Es wird nicht das gesamte mitgelieferte Befestigungsmaterial verwendet.

Schritt 1 Befestigen Sie die Schienen am Fernseher Siehe Seite 2

Mitgelieferte Teile und Befestigungsmaterialien

1-1 Wählen Sie Schrauben für den Fernseher aus

1-2 Abstandhalter?

I Wenn nein, siehe Seite 3, Kombination **I**.

II Wenn ja, siehe Seite 3, Kombination **II**.

1-3 Befestigen Sie die Fernseher-Schienen

Tipps: Bei der Verwendung von M6(e) / M8(c / f) Schrauben, wenn dabei ein Abstandhalter (j) von 2,5mm gleichzeitig gebraucht wird, entfernen Sie dabei bitte den eingebauten Ring.

Schritt 2 Befestigen Sie die Wandplatte an der Wand

Mitgelieferte Teile und Befestigungsmaterialien

Schritt 2A Die Montage von Holzbalkenwand Siehe Seite 4

⚠️ Vorsicht: Verwenden Sie keinen Dübel, wenn Sie eine Wandplatte an einer Holzbalkenwand installieren!

⚠️ Vorsicht: Alle fünf Sechskant-Holzschrauben **01** müssen festgezogen werden, um ein ungewolltes Verrutschen der Wandplatte zu verhindern. Achten Sie darauf, dass die Wandplatte sicher an der Wand befestigt ist, bevor Sie mit dem nächsten Schritt anfangen.

Fahren Sie bitte nach diesem Schritt mit 3. Schritt auf der Seite 7 fort.

Um das Herunterfallen des Fernsehers zu verhindern, muss der Schraubenkopf in diesem Schritt nach oben zeigen!!

Schritt 2B Die Montage von Massivbetonwand Siehe Seite 6

⚠️ Vorsicht: Alle fünf Sechskant-Holzschrauben **01** müssen festgezogen werden, um ein ungewolltes Verrutschen der Wandplatte zu verhindern. Achten Sie darauf, dass die Wandplatte sicher an der Wand befestigt ist, bevor Sie mit dem nächsten Schritt anfangen.

Um das Herunterfallen des Fernsehers zu verhindern, muss der Schraubenkopf in diesem Schritt nach oben zeigen!!

Schritt 3 Hängen und befestigen Sie den Fernseher an der Wandplatte Siehe Seite 7

Eine Sicherheitsprüfung für die Montage der Wandplatte

Bevor Sie den Fernseher an die Wandplatte hängen, führen Sie bitte eine Sicherheitsprüfung für die Montage der Wandplatte aus.

Hängen und befestigen Sie den Fernseher an der Wandplatte

⚠️ Vorsicht: Nachdem der Fernseher sicher an der Wandplatte aufgehängt wurde, verriegeln Sie die Sicherheitsschrauben **03** mit einem Schraubendreher, um sicherzustellen, dass keine Lockerheit auftritt.

*Aus Sicherheitsgründen wird dieser Schritt am besten von zwei Personen gemeinsam ausgeführt.

Schritt 4 Funktionseinstellung Siehe Seite 8

4-1 Nivellierungseinstellung (+/-3°)

Verwenden Sie einen Inbusschlüssel **02** und lösen Sie die zwei hinter der TV-Platte eingebettete Nivellierschrauben (Nicht mehr als zwei Umdrehungen) gegen den Uhrzeigersinn, stellen Sie die TV-Platte ein und ziehen Sie die Schrauben mit einem Schraubenschlüssel im Uhrzeigersinn fest.

4-2 Neigungseinstellung (+5°/-12°)

Lösen Sie zuerst den Griff und die Neigungsschraube, stellen Sie dann das Fernsehgerät auf den gewünschten Winkel ein und ziehen Sie schließlich den Griff und die Neigungsschraube fest, um den Neigungswinkel zu fixieren.

Produktabmessung Siehe Seite 9

Avant l'installation, veuillez assurer que ce support est adapté à votre téléviseur ou pas !

1 Est-ce que la distance entre des trous de montage de votre téléviseur est plus de ou égale à 200x100mm/8x4" et moins de ou égale à 800x400mm/32x16"?

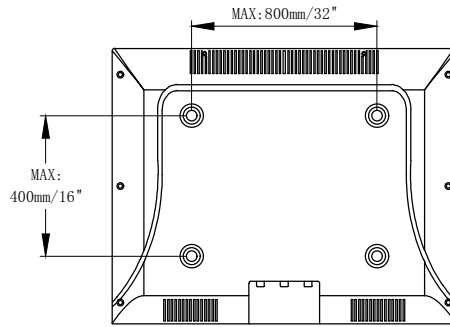

Oui - Parfait !

Non - Ce support ne vous convient pas !

2 Est-ce que votre téléviseur et des autres accessoires pèsent totalement moins de 68 kg (150 LBS)?



Oui - Parfait !

Non - Ce support ne vous convient pas !

3 De quels genres matériaux le mur est fait ?

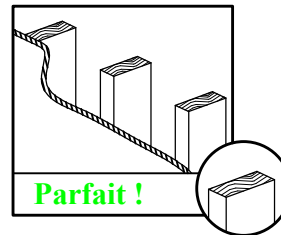
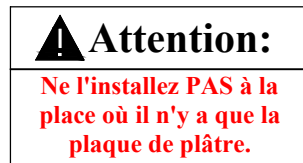

Cloison sèche avec montant en bois ?

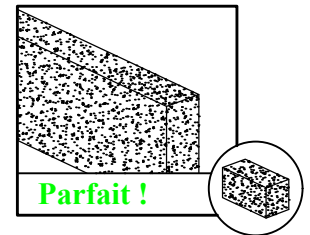

Mur en béton plein ?

4 Outils d'installation (Pas inclus)

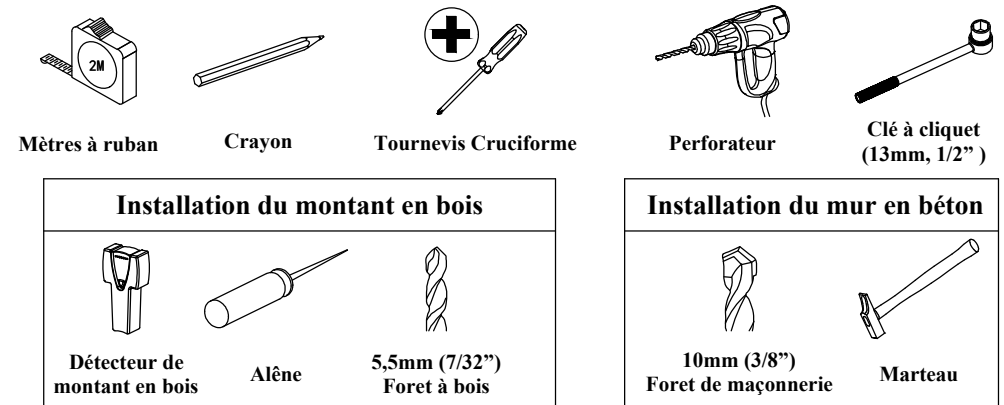

5 Consignes de sécurité

Avant l'installation, veuillez attentivement lire ce mode d'emploi.

- Ce produit s'applique au montant en bois, au mur en béton plein - Ne l'installez pas à la place où il n'y a que la plaque de plâtre.
- La force portante du mur doit atteindre au moins cinq fois du poids total de votre téléviseur et du support.
- N'utilisez pas ce produit pour des autres objectifs non désignés par Mounting Dream.
- L'installation incorrecte causera le dommage matériel ou la blessure corporelle. Mounting Dream n'assumera aucune responsabilité pour le dommage et la blessure causés par l'installation incorrecte ou l'utilisation inadéquate.

⚠ AVERTISSEMENT : Ce produit contient des petites pièces, en cas d'ingestion, des risques de suffocation y arrivera. Avant l'installation, veuillez vérifier que tous les accessoires et toutes les pièces sont complets et non défectueux.

ATTENTION : Les pièces fournies ne seront pas toutes utilisées durant l'installation.

Étape 1 Installer des barres verticales sur votre téléviseur Voir à la page 2

Pièces et accessoires

1-1 Choisir des vis de téléviseur

1-2 Entretoises sont nécessaires ?

I Non, voir à la page 3, combinaison **I**.

II Oui, voir à la page 3, combinaison **II**.

1-3 Assembler des barres verticales

Remarque : Quand vous choisissez la vis M6(e) / M8(c / f) et l'entretoise (j) de 2,5mm est nécessaire, veuillez enlever la cerce interne.

Étape 2 Installer la plaque murale au mur

Pièces et accessoires

Étape 2A Installation du montant en bois Voir à la page 4

⚠ Attention : Quand vous installez la plaque murale au mur avec le poteau de bois, n'utilisez pas les chevilles!

⚠ Attention : Tous les cinq boulons tire-fond **01** doivent être fermement serrés pour éviter le mouvement non souhaité de la plaque murale. Veuillez vérifier que la plaque murale est fixée sur le mur avant de passer à l'étape suivante. Après avoir fini cette étape, allez directement à la page 7 et continuez l'étape 3.

Pour éviter que le téléviseur ne tombe, la tête du boulon doit faire face vers le haut !!

Étape 2B Installation du mur en béton plein Voir à la page 6

⚠ Attention : Tous les cinq boulons tire-fond **01** doivent être fermement serrés pour éviter le mouvement non souhaité de la plaque murale. Veuillez vérifier que la plaque murale est fixée sur le mur avant de passer à l'étape suivante.

Pour éviter que le téléviseur ne tombe, la tête du boulon doit faire face vers le haut !!

Étape 3 Suspendre et fixer votre téléviseur sur la plaque murale Voir à la page 7

Pièces et accessoires

Test de la fiabilité de l'installation de la plaque murale

Avant de suspendre votre téléviseur sur la plaque murale, veuillez tester la fiabilité de l'installation de la plaque murale.

Suspendre et fixer votre téléviseur sur la plaque murale

⚠ Attention : Après avoir suspendu votre téléviseur sur la plaque murale, veuillez bien serrer les vis de sécurité **03** au tournevis cruciforme pour assurer qu'elles sont fixes.

*Compte tenu de la sécurité, deux personnes sont nécessaires pour l'installation.

Étape 4 Ajustement de fonction Voir à la page 8

4-1 L'ajustement du niveau (+/-3°)

Desserrer à la clé hexagonale **02** les deux vis de niveau à l'arrière de la plaque TV (pas plus de deux tours), ajuster le niveau et puis serrer les vis.

4-2 L'ajustement de l'angle d'inclinaison (+5°/-12°)

Tout d'abord, desserrer la poignée et la vis d'inclinaison, puis ajuster votre téléviseur à l'angle souhaitée, bien serrer la poignée et la vis d'inclinaison.

Dimensions de produit Voir à la page 9

Antes de comenzar a instalar este soporte mural para tv , favor confirme si es el adecuado para su televisor!

1 Los orificios posteriores de su televisor tienen una distancia mayor o igual a 200x100mm/8x4" y menor o igual a 800x400mm/32x16"?

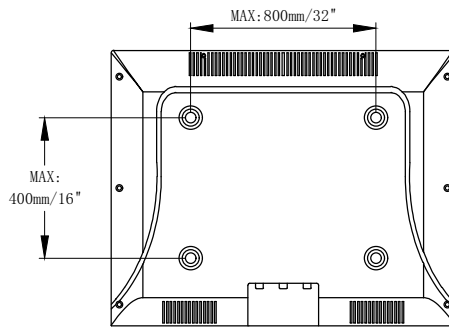

Si - Es el adecuado!

No - Este soporte no es el adecuado!

2 El peso de su televisor y los demás accesorios en total es menor a 68 kg (150 LBS)?



Si - Es el adecuado!

No - Este soporte no es el adecuado!

3 La pared de que material esta construida?

⚠ Atención:
En paredes de yeso o derivados no se debe instalar.

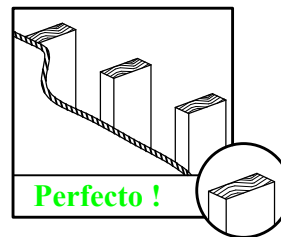

Instalar en paredes con pilares de madera?

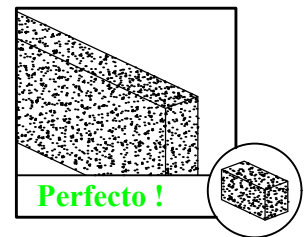

Instalar en paredes de hormigón sólido ?

4 Herramientas necesarias para su instalación (No incluido)

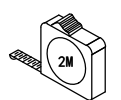

Cinta Métrica



Lápiz



Destornillador de Cruz

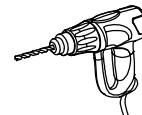

Taladro Eléctrico

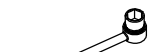

Juego de llaves (13mm, 1/2")

Instalación en pared con pilares de madera

Detector de Madera Punzón 5,5mm (7/32") Broca para Madera

Instalación en pared de hormigón

10mm (3/8") Broca de Impacto Martillo

5 Advertencias de seguridad

Antes de la instalación favor de leer en detalle el manual de instrucciones.

- Este producto es apto para paredes con pilares de madera, y muro de hormigón sólido - No instalar en paredes de solo yeso.
- La capacidad de soporte de la pared debe ser cinco veces más que el peso total del televisor y el soporte.
- Favor NO utilizar el producto de Mounting Dream para otros usos no asignados.
- La instalación incorrecta puede producir daños al producto o lesiones al usuario. Cualquier pérdida o daño debido por la mala instalación o uso indebido, Mounting Dream no asume ninguna responsabilidad.

Instrucciones paso a paso de su instalación

⚠ Advertencia: Este producto contiene piezas pequeñas, si por error se ingiere, puede provocar peligro de asfixia. Antes de comenzar la instalación, favor compruebe que todos los accesorios y piezas de repuesto estén completas y sin daño alguno.

Atención: No todas las piezas se utilizarán.

Paso 1 Instalar las varillas del soportes al televisor Ver página 2

Accesorios y piezas

1-1 Elegir los tornillos para el televisor

1-2 Necesito espaciadores?

I No necesito, favor ver la combinación **I** en la página 3.

II Necesito, favor ver la combinación **II** en la página 3.

1-3 Instalar las varillas del soporte

Tips: Si necesita espaciadores de 2,5mm (j) combinados con tornillos de M6(e) / M8(c / f), favor retirar la argolla/anillo.

Paso 2 Instalar la placa mural

Accesorios y piezas

Paso 2A Instalación en pared con pilares de madera Ver página 4

⚠ Atención: Al momento de instalar el panel en la pared con pilares de madera, favor no usar los tacos/tarugos para la pared de hormigón!

⚠ Atención: Los cinco tornillos **01** de cabeza hexagonal deben apretarse firmemente, para evitar que la placa mural en la pared se mueva. Favor de asegurarse que quede firmemente estable en la pared para poder continuar con los siguientes pasos de la instalación. Luego de terminar este paso favor continuar con el paso 3 en la página 7.

Para prevenir que el televisor se caiga, durante este paso, la cabeza del tornillo debe ir hacia arriba! !

Paso 2B Instalación en pared de hormigón sólido Ver página 6

⚠ Atención: Los cinco tornillos **01** de cabeza hexagonal deben apretarse firmemente, para evitar que la placa mural en la pared se mueva. Favor de asegurarse que quede firmemente estable en la pared para poder continuar con los siguientes pasos de su instalación.

Para prevenir que el televisor se caiga, durante este paso, la cabeza del tornillo debe ir hacia arriba! !

Paso 3 Colgar y sujetar del televisor a la placa mural Ver página 7

Accesorios y piezas

Prueba de confiabilidad a la instalación de la placa mural

Antes de colgar el televisor en la placa mural, favor realizar una prueba de confiabilidad a la instalación.

La colocación y sujeción del televisor a la placa mural

⚠ Atención: Después de colgar el televisor en el soporte mural, favor use el destornillador para apretar los tornillos **03** de seguridad, asegurando que no haya ningún afloje.

* Por razones de seguridad, para concluir este paso es mejor hacerlo en compañía de otra persona.

Paso 4 Funciones de regulación Ver página 8

4-1 Regulación de nivel (+/-3°)

Use una llave hexagonal **02** y afloje (máximo 2 vueltas) los 2 tornillos de nivelación que están detrás de la placa del televisor, regule el nivel, y luego vuelva a apretar los tornillos.

4-2 Regulación del ángulo de inclinación (+5°/-12°)

Primero afloje la manilla y el tornillo de inclinación, luego ajuste su televisor al ángulo deseado, y por último vuelva a apretar la manilla y el tornillo.

Dimensiones del producto Ver página 9

Prima di iniziare l'installazione, per prima cosa conferma se questo Supporto è ideale per la vostra TV!

1 La distanza dei fori di installazione TV sono superiore/uguale a 200x100mm/8x4" e inferiore /uguale a 800x400mm/32x16"?

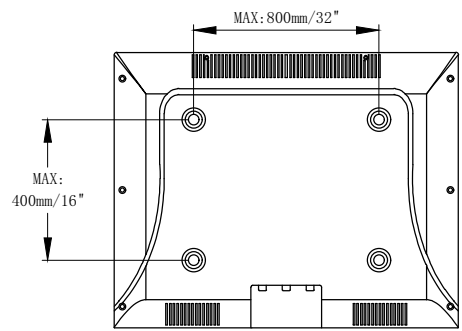

Sì - Ideale!
No - Questo supporto non va!

2 Il tuo televisore (inclusi accessori) pesa totalmente inferiore a 68 kg (150LBS)?



Sì - Ideale!
No - Questo supporto non va!

3 Di che materiale è fatto il muro?

⚠ Cautela:
Non installarlo in un posto solo in cartongesso.

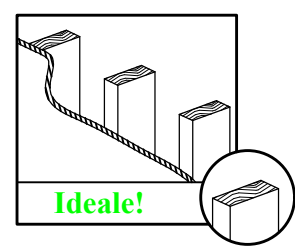

Muro secco con i pilastri in legno?

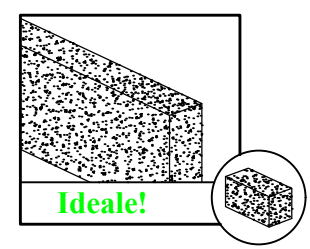

Muro in calcestruzzo solido ?

4 Utensili per installazione (Non incluso)

Metro a nastro	Matita	Cacciavite a croce	Trapano elettrico	Chiave a tubo 13mm (1/2")
<p>Installazione di pilastri in legno</p> Rivelatore di pilastro in legno Punteruolo 5,5mm (7/32") Punta da trapano per legno			<p>Installazione sui muri di calcestruzzo</p> 10mm (3/8") Punta da trapano a percussione Martello	

5 Cautele per sicurezza

- Leggi attentamente le istruzioni prima di installazione.
- Questo prodotto è progettato per pilastri in legno e muri in calcestruzzo solido - NON installarlo in soli cartongessi.
 - Il muro deve essere capace di portare almeno cinque volte il peso totale del televisore e del supporto.
 - Non applicare questo prodotto ad altri scopi non indicati da Mounting Dream.
 - L'installazione errata potrebbe causare danni al prodotto o lesioni personali. Mounting Dream non si assume alcuna responsabilità per danni o lesioni causate da installazione impropria o uso improprio.

Istruzioni di installazione

⚠ Avvertenza: Questo prodotto contiene piccoli articoli che potrebbe causare il pericolo di soffocamento se ingoiati. Prima di iniziare l'installazione, controlla se tutti gli accessori e parti siano inclusi e non danneggiati.

Nota: Non verranno utilizzati tutte le parti incluse.

Passo 1 Installa barre verticali al televisore Vedi pagina 2

Accessori e parti

1-1 Seleziona viti TV

1-2 Si ha bisogno di pilastri con guarnizione?

I No, vedi la combinazione **I** nella pagina 3.

II Sì, vedi la combinazione **II** nella pagina 3.

1-3 Installazione di barre verticali

Suggerimento: se è necessario combinare il pilastro con guarnizione 2,5mm (j) con la vite M6(e) / M8(c / f), rimuovi l'anello interno.

Passo 2 Installa la piastra a muro sul muro

Accessori e parti

Passo 2A Installazione sul muro con i pilastri in legno Vedi pagina 4

⚠ Cautela: Quando si installa la piastra a muro sul muro con pilastri in legno, non utilizzare i tasselli per il muro in calcestruzzo!

⚠ Cautela: Le cinque viti **01** per Legno a testa esagonale devono essere avvitate bene in modo da evitare movimenti indesiderati della piastra a muro. Assicura che la piastra a muro sia ben fissata sul muro prima di eseguire il prossimo passo. Dopo finire questo passo, va direttamente alla pagina 7 per il passo 3.

Per evitare che la TV cada, la testa del bullone deve essere rivolta verso l'alto!!

Passo 2B Installazione sul muro in calcestruzzo Vedi pagina 6

⚠ Cautela: Le cinque viti **01** per Legno a testa esagonale devono essere avvitate bene in modo da evitare movimenti indesiderati della piastra a muro. Assicura che la piastra a muro sia ben fissata sul muro prima di eseguire il prossimo passo.

Per evitare che la TV cada, la testa del bullone deve essere rivolta verso l'alto!!

Passo 3 Appendi e fissa la TV alla piastra a muro Vedi pagina 7

Test di affidabilità dell'installazione della piastra a muro

Prima di appendere la TV alla piastra a muro, esegui un test di affidabilità dell'installazione della piastra a muro.

Appendi e fissa la TV alla piastra a muro

⚠ Cautela: Dopo appendere la TV alla piastra a muro, avvita bene le viti **03** di sicurezza con un cacciavite assicurando che non si allenti.

* Per la sicurezza, è meglio eseguire questo passo da due persone.

Passo 4 Regolazioni di funzione Vedi pagina 8

4-1 Regolazione di livello (+/-3°)

Allenta (due cerchi al massimo) con la chiave a brugola interna **02** le due viti di livellamento sul retro della piastra TV, le regola al livello e le avvita nuovamente per fissarle.

4-2 Regolazione dell'angolo di inclinazione (+5°/-12°)

Prima, allenta la maniglia e la vite di regolazione di inclinazione, quindi gira la TV all'angolo desiderato, infine stringi la maniglia e la vite di regolazione di inclinazione per fissare l'angolo di inclinazione.

Dimensioni del prodotto Vedi pagina 9