

Mounting Dream

MD2268-S INSTALLATION INSTRUCTION

Für die Installationsanweisungen auf Deutsch, siehe Seite 10~11.

Pour l'instruction en Français, veuillez vous reporter à la page 12~13.

Para las instrucciones de la instalación en Español, favor vea la página 14~15.

Per le Istruzioni in Italiano, vedi pagina 16~17.

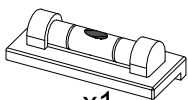
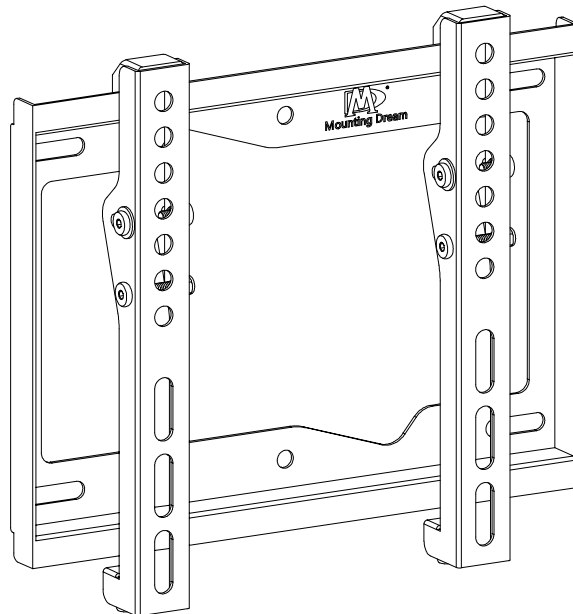

x1

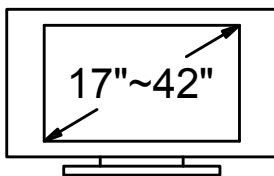

Max:200x200mm/8x8"

Min:75x75mm/3x3"

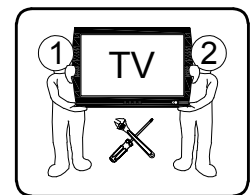

(C1)

Before getting started, let's make sure this mount is perfect for you!

1 Is your TV VESA equal to/greater than 75x75mm/3x3" and equal to/less than 200x200mm/8x8"?

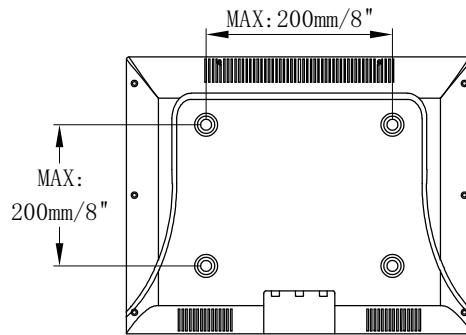

Yes --- Perfect!

No --- This mount is **NOT** compatible.

2 Does your TV (including accessories) weigh less than 44 LBS (20 kg)?



Yes --- Perfect!

No --- This mount is **NOT** compatible.

3 What is your wall made of?

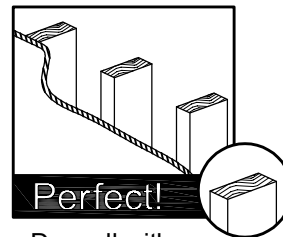

Drywall with wood studs?

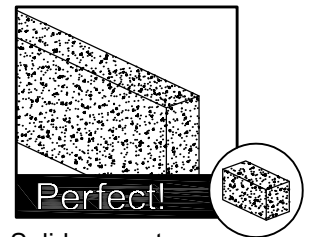

Solid concrete wall?

4 Installation Tools (Not Included)

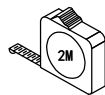

Band Tape



Pencil



Screwdriver

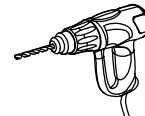

Electrodrill



Socket Wrench 1/2"(13mm)

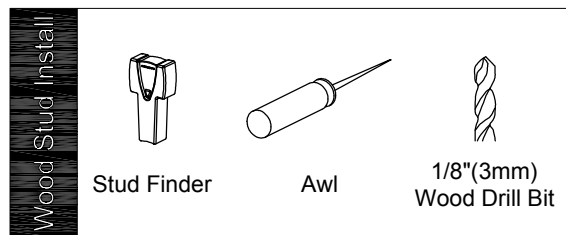

Stud Finder

Awl

1/8"(3mm) Wood Drill Bit

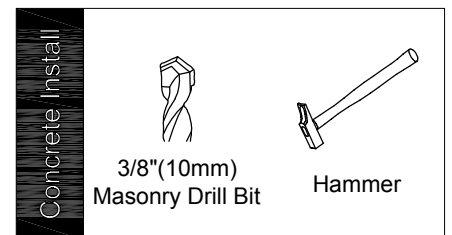

3/8"(10mm) Masonry Drill Bit

Hammer

5 Safety Caution

Please read this instruction carefully before installation.

- This product is designed for use in wood stud and solid concrete wall. - DO NOT install into drywall alone.
- The wall must be capable of supporting five times the weight of the TV and mount combined.
- Do not apply this product to any purpose not indicated by Mounting Dream.
- Incorrect installation may result in product damage or body injury. Mounting Dream shall bear no responsibility for any damage or injury resulted from incorrect installation, incorrect assembly or misuse.

STEP 1 Attach Brackets to TV

Parts and Hardware

⚠ WARNING: This product contains small items that could be a choking hazard if swallowed. Before starting assembly, verify all parts are included and undamaged.

NOTE: Not all hardware included will be used.

TV Brackets

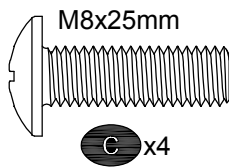
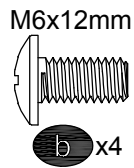
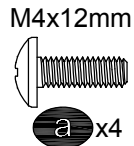
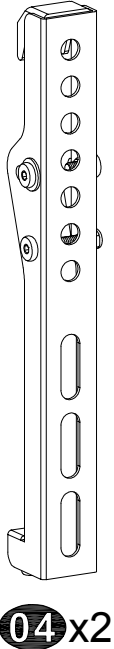

TV Screws

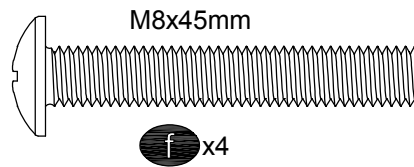
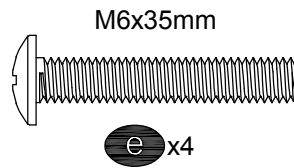
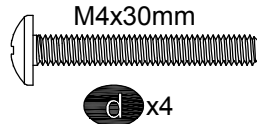

Spacers

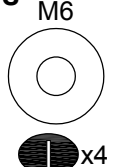
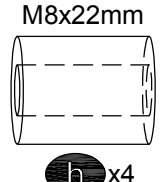
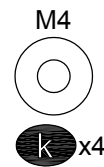
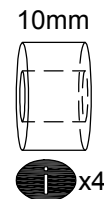
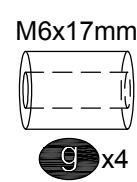

Washers

1-1 Select TV Screws

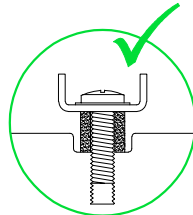
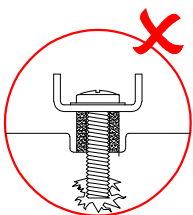
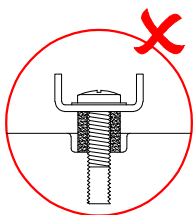
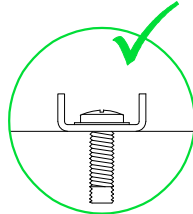
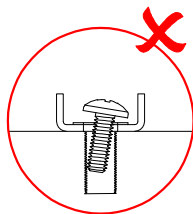
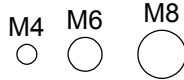
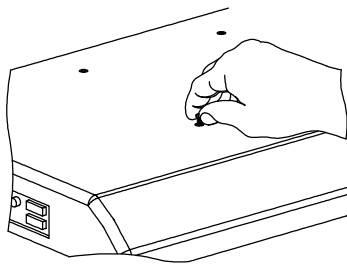

1-2 Need Spacer?

I Yes, go to PAGE 3 **I** for detailed combination.

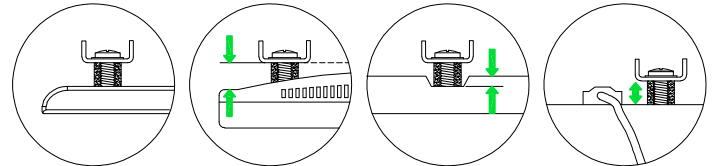
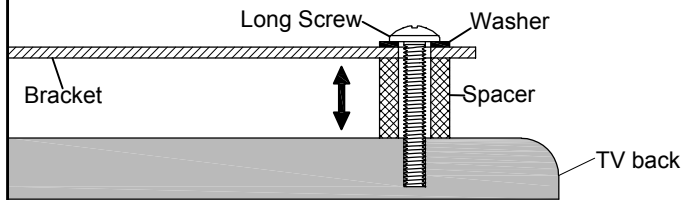

Highly recommended to add spacers for more spacing between wall mount and wall.

II No, go to PAGE 3 **II** for detailed combination.

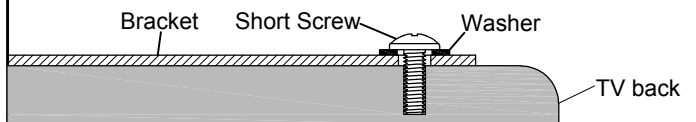

1-3 Attach the TV Brackets

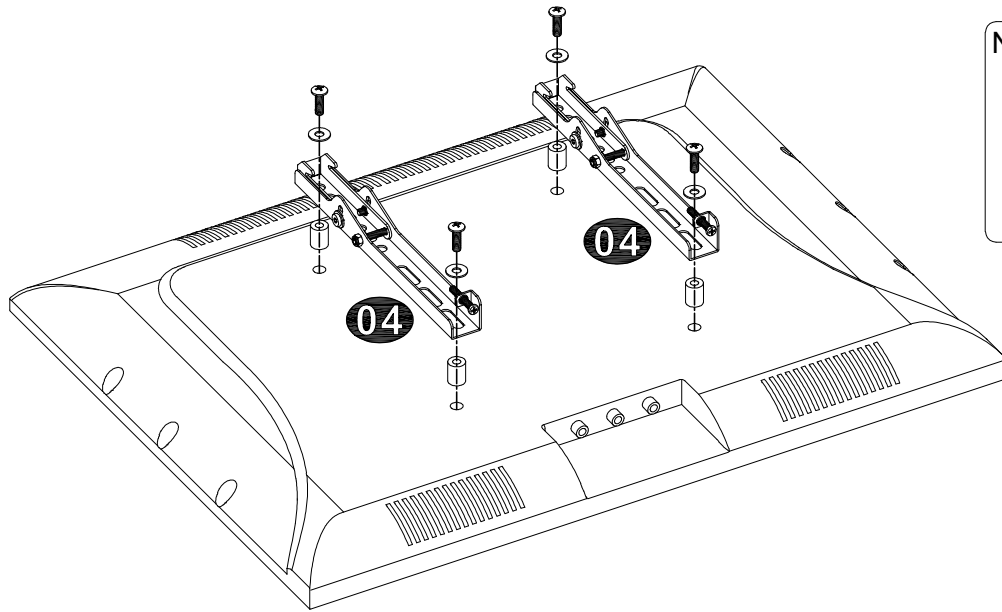

I Spacer(s), screw and washer

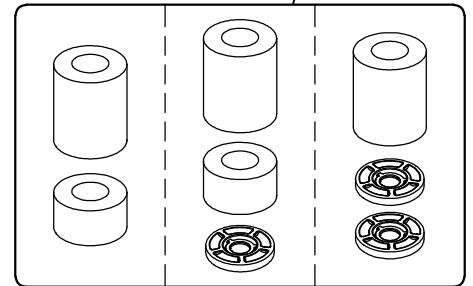
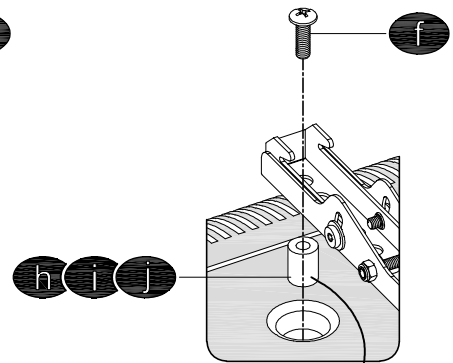
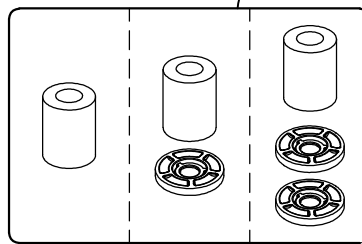
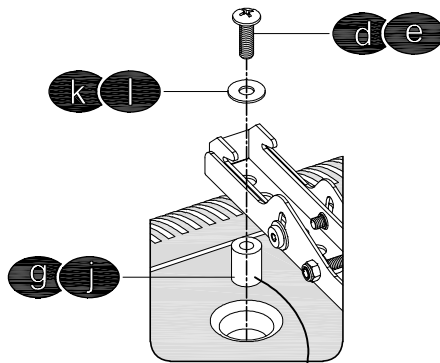
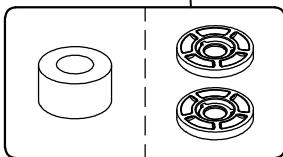
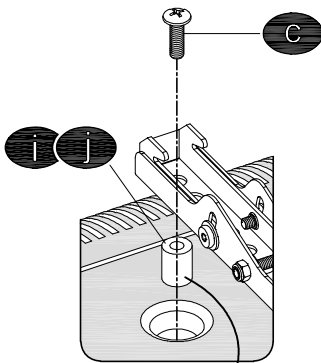

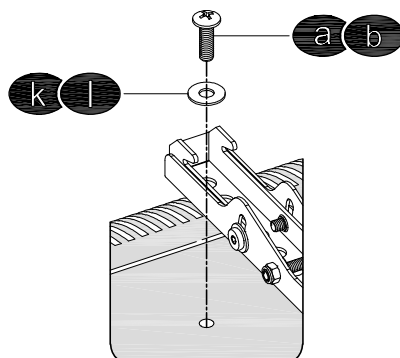

Tips: If you need to combine M6(e) or M8(c/f) screw with 2.5mm spacer(j), you have to remove the inner circle.

II Screw and washer



STEP 2 Attach Wall Plate to Wall

-  For wood stud installation, follow STEP 2A
-  For concrete installation, follow STEP 2B on PAGE 6

Parts and Hardware

Wall Plate

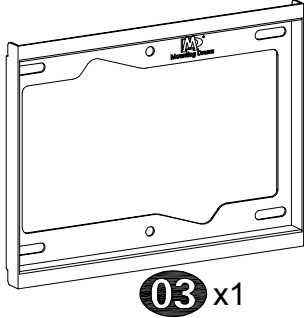

Mounting Template

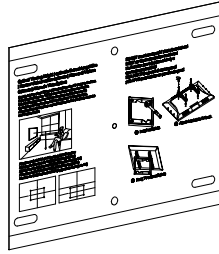

Lag Bolt M6x50mm

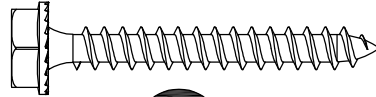

01 x4

Allen Key

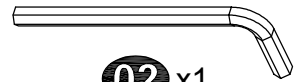

02 x1

Concrete wall anchor (NOT INCLUDED)

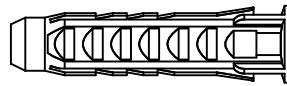

Concrete Wall Anchor
4pcs

STEP 2A

Wood Stud Installation

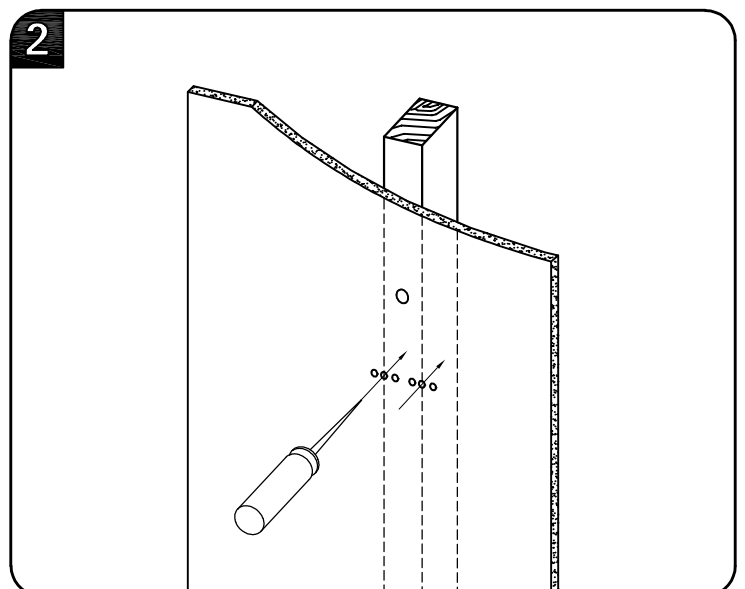
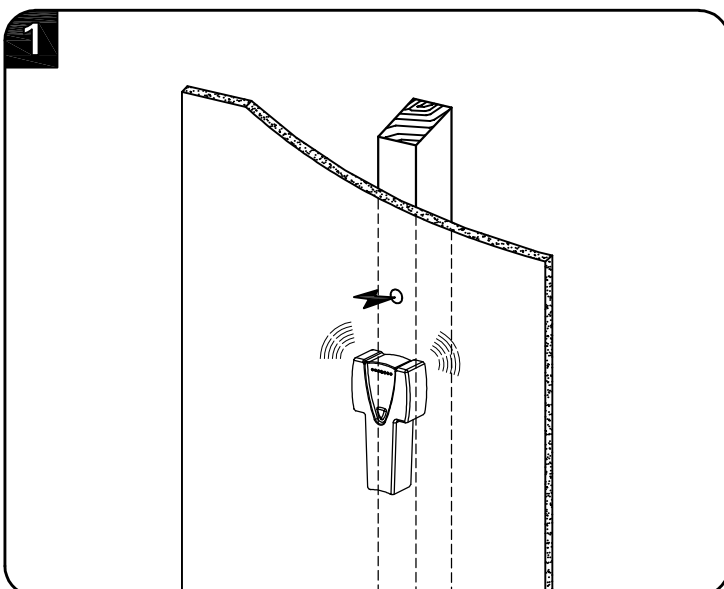
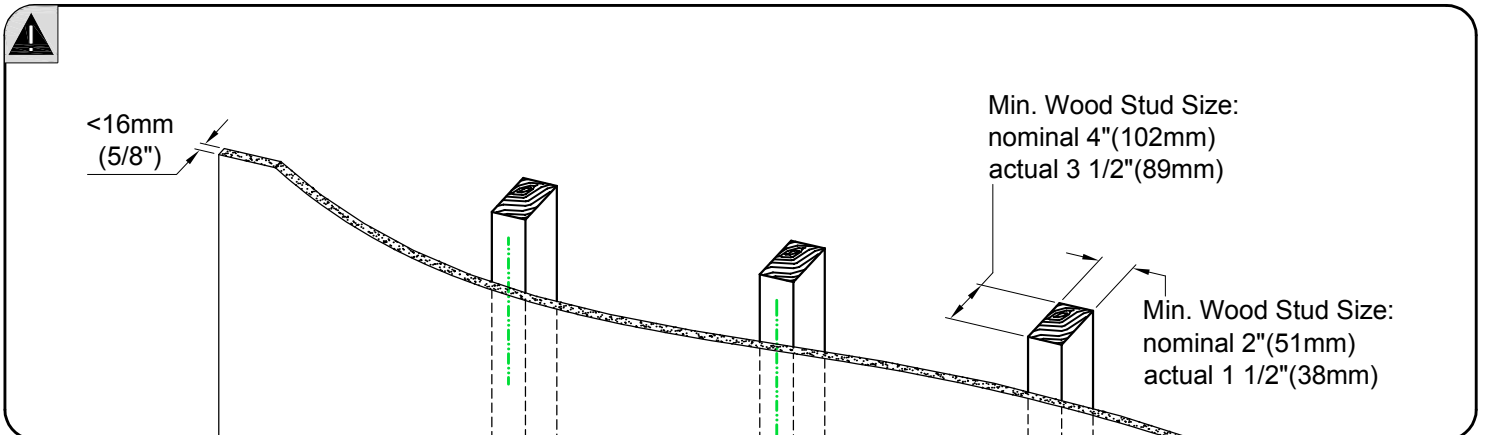

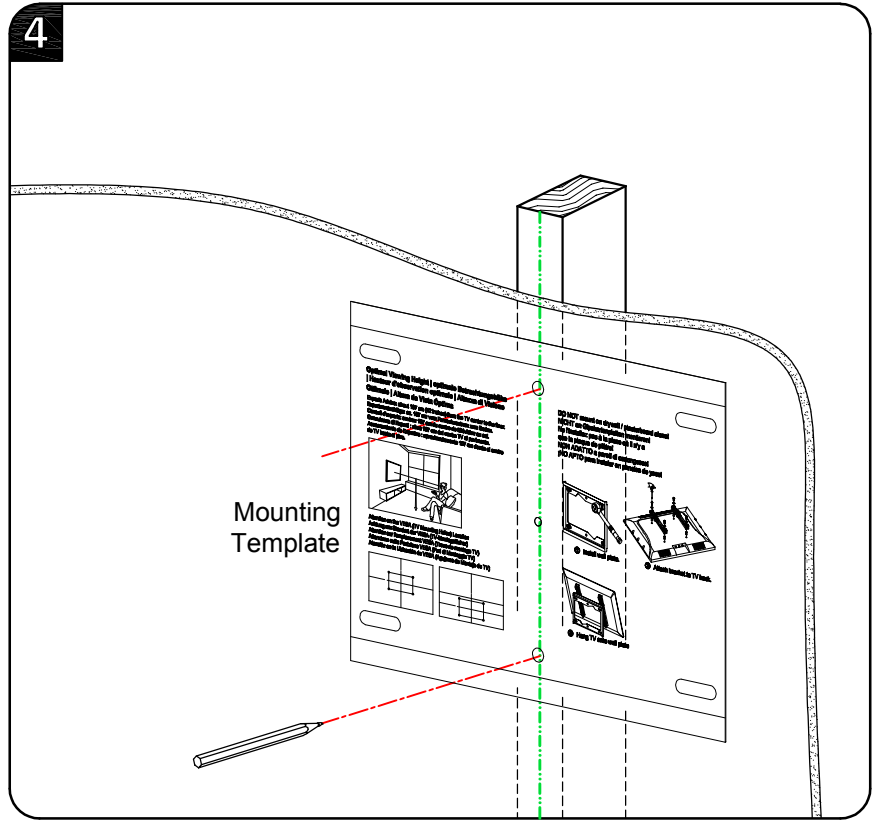
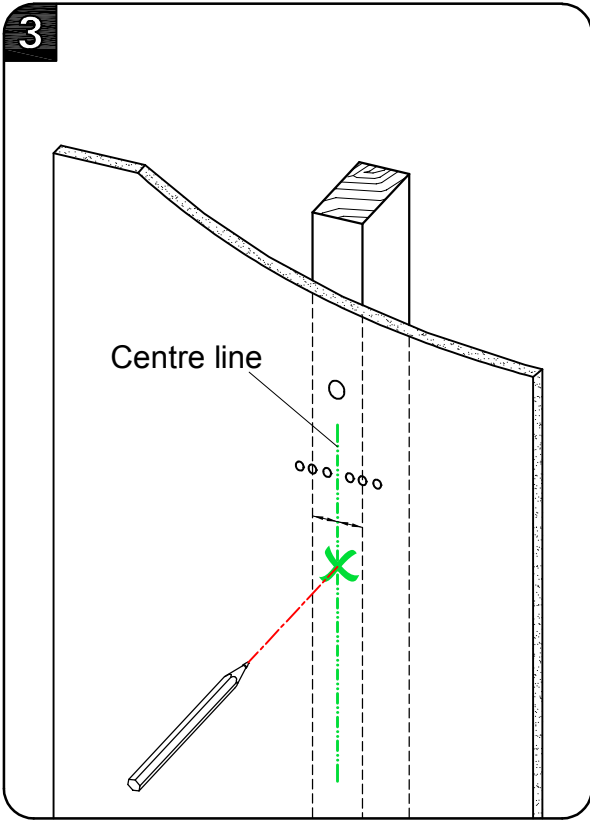

⚠ CAUTION: To avoid potential personal injury or property damage: All 2 lag bolts **01** MUST BE firmly tightened to prevent unwanted movement of the wall plate assembly. Ensure the wall plate assembly is securely fastened to the wall before continuing on to the next step.

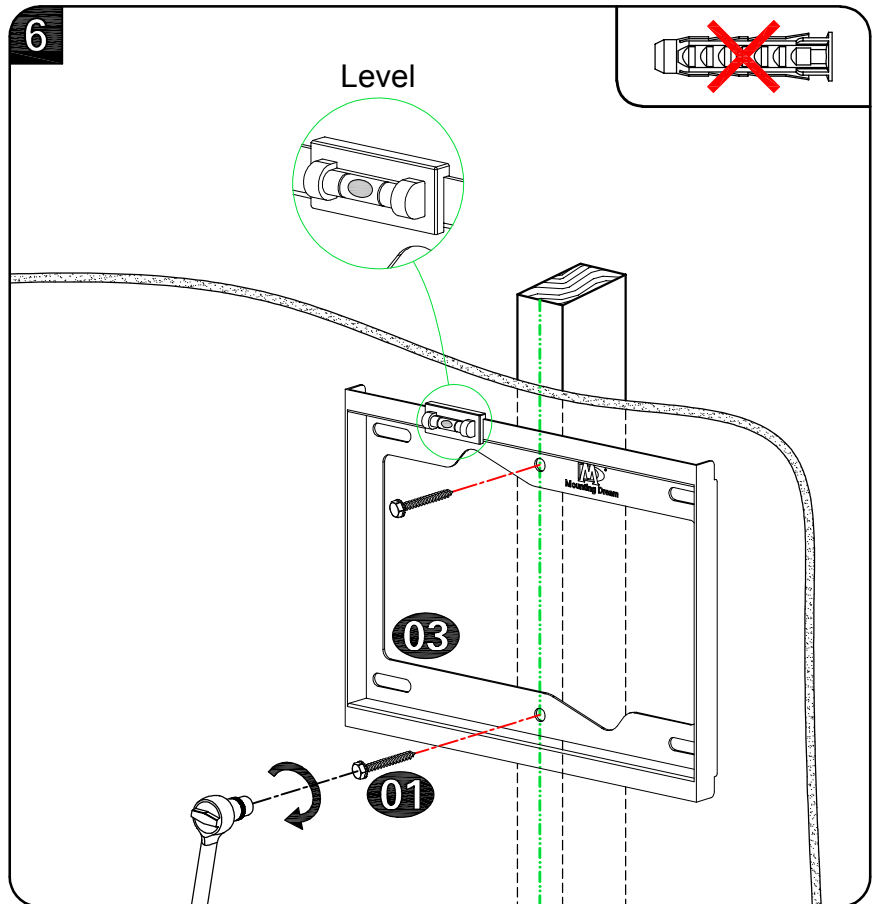
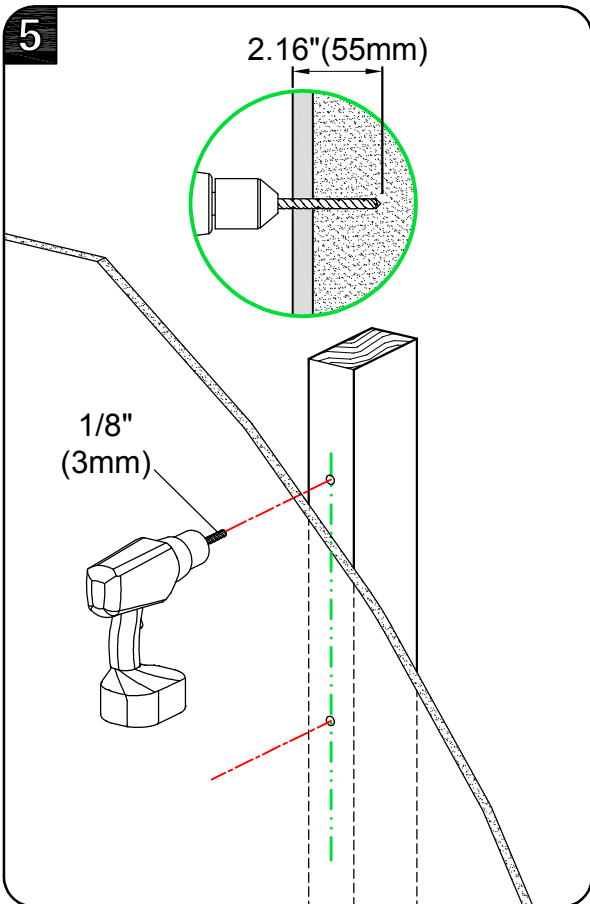

Go to Step 3 on PAGE 7.

STEP 2B

Solid Concrete Wall Installation

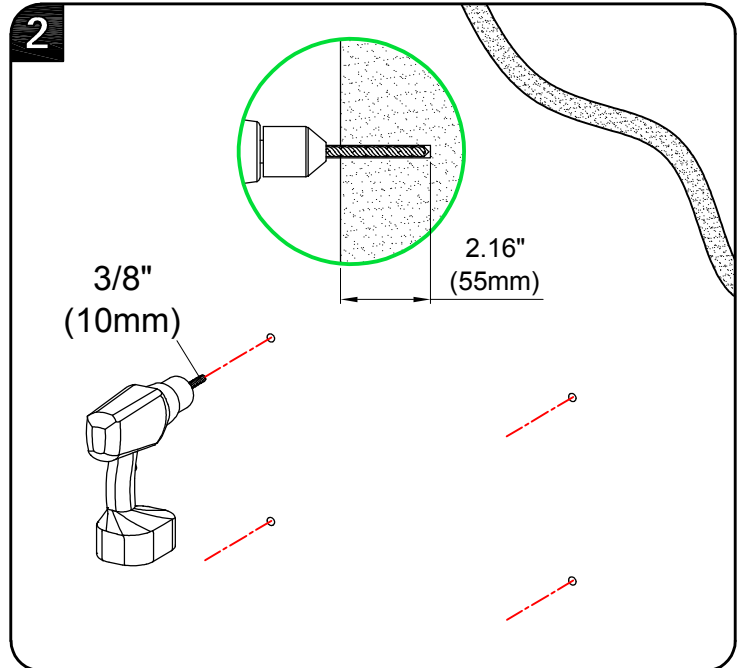
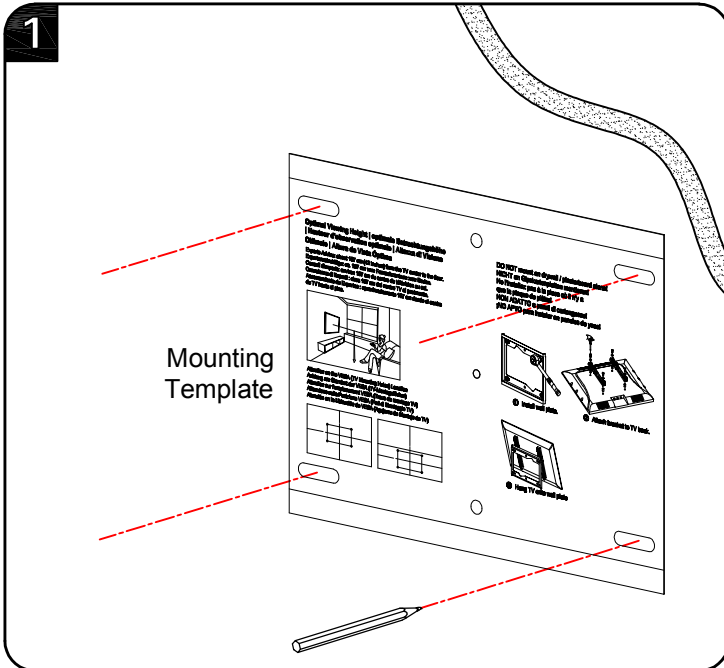
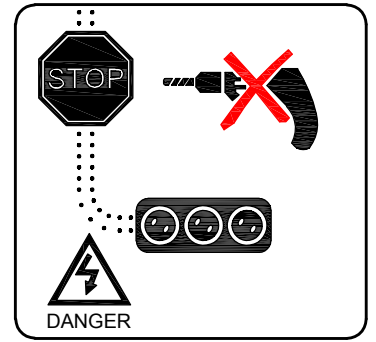
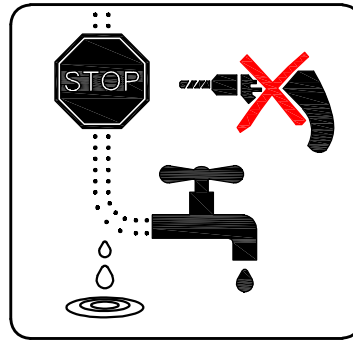
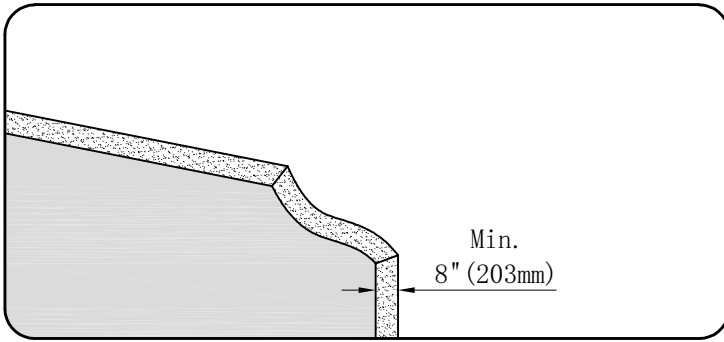

⚠ CAUTION: To avoid potential personal injury or property damage:
All 4 lag bolts **01** MUST BE firmly tightened to prevent unwanted movement of the wall plate assembly. Ensure the wall plate assembly is securely fastened to the wall before continuing on to the next step.

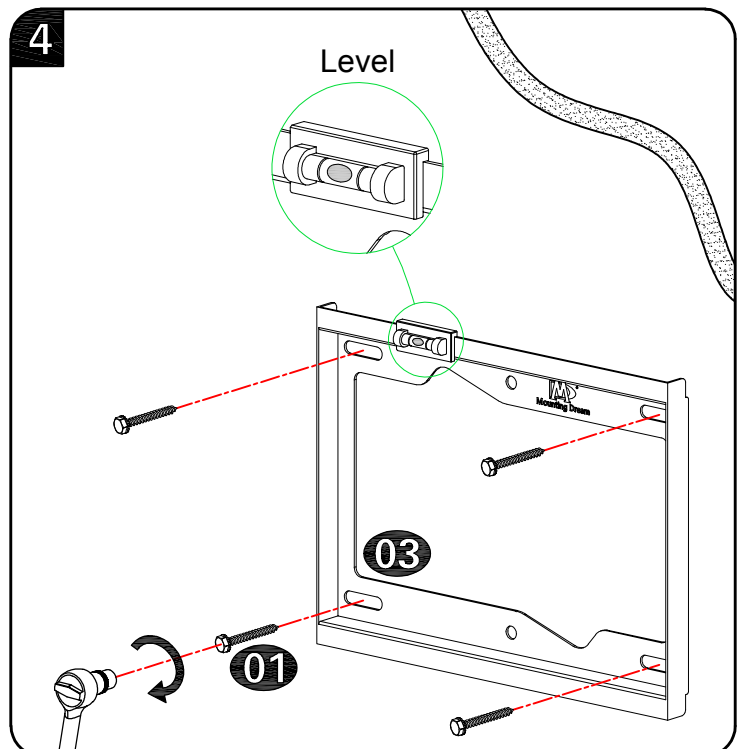
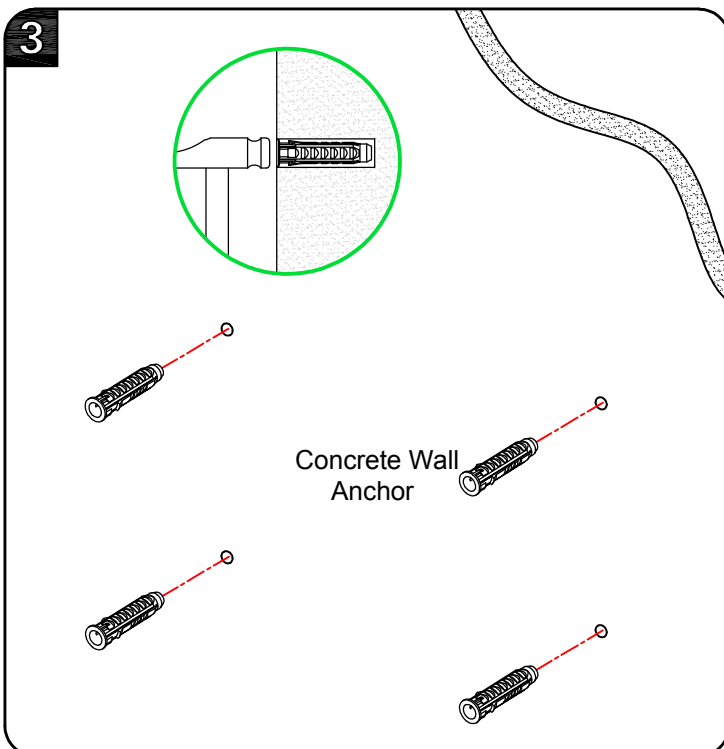

STEP 3 Hang and Secure TV to Wall Plate

Before hanging TV, please conduct "wall plate installation integrity test" first.

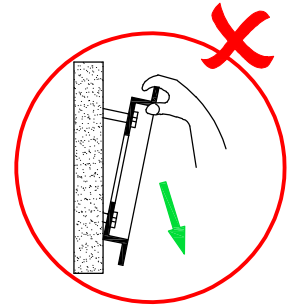
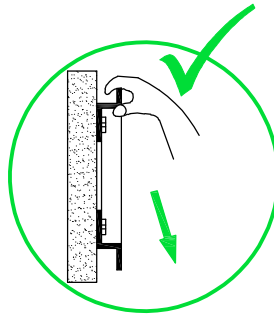
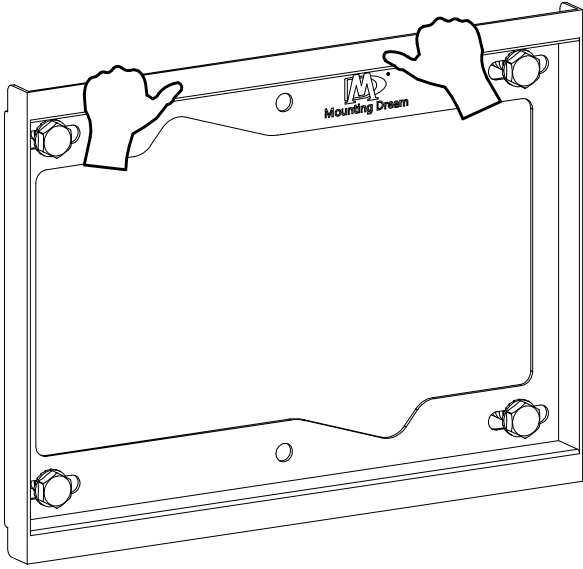

44 LBS (20 kg)

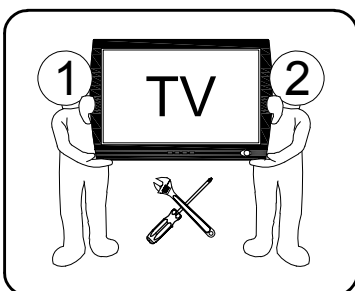
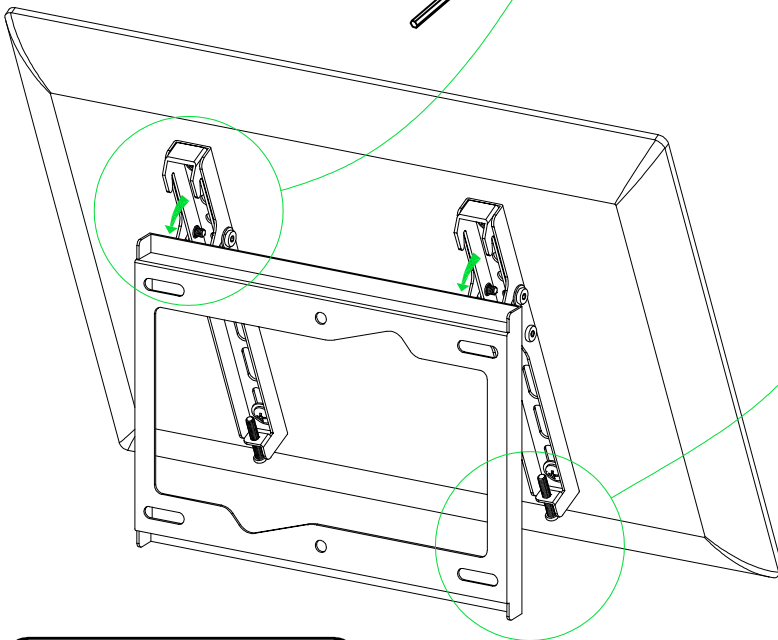
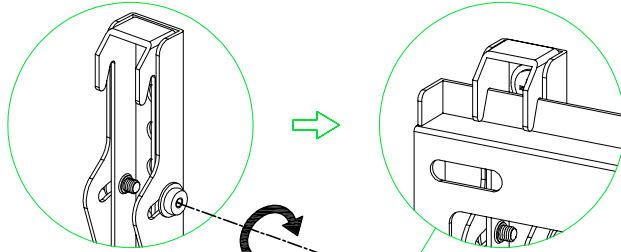

Tips: Do not fasten the safety screws too much for easy adjustment of tilting.

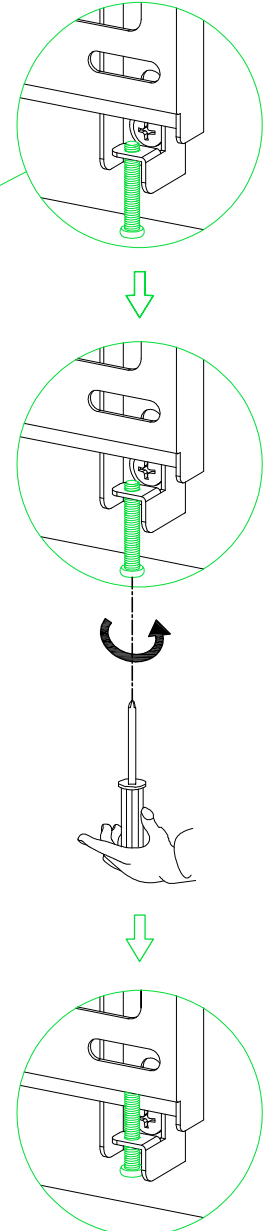

STEP 4 Adjustments

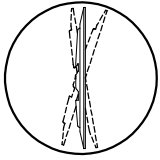

Tilting angle adjustment (0° / -8°):

Pull TV to your desired angle then fasten 2 tilting bolts with Allen key **02**.

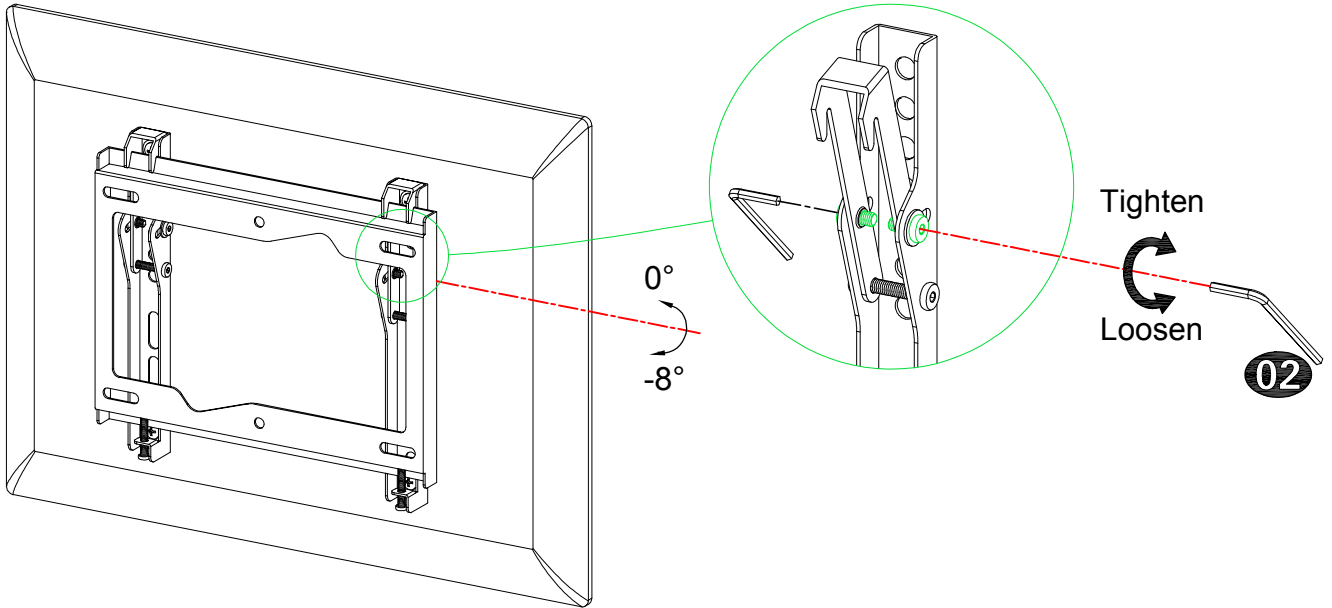

STEP 5 Take Down the TV from the Mount

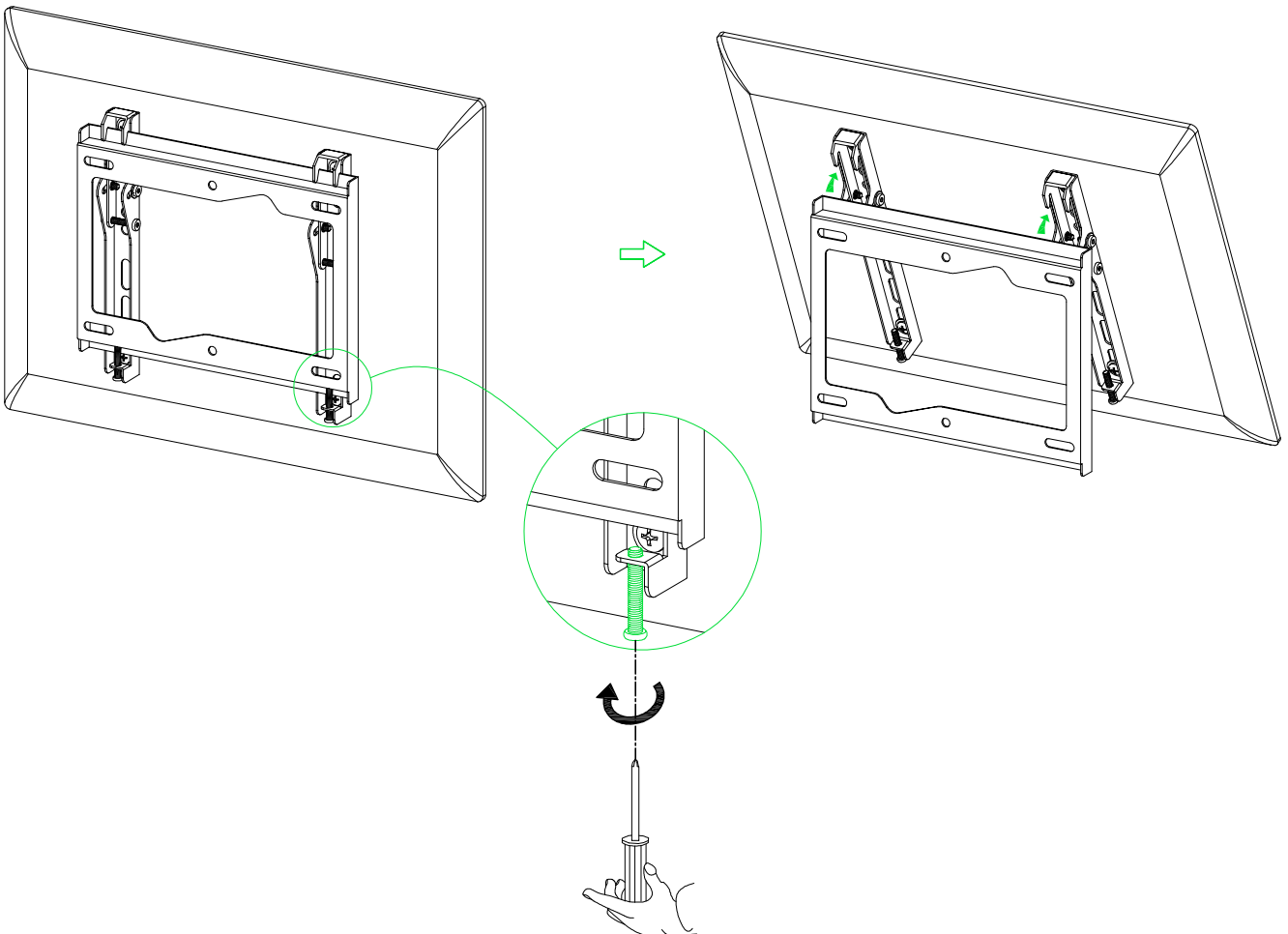

Product dimensions:

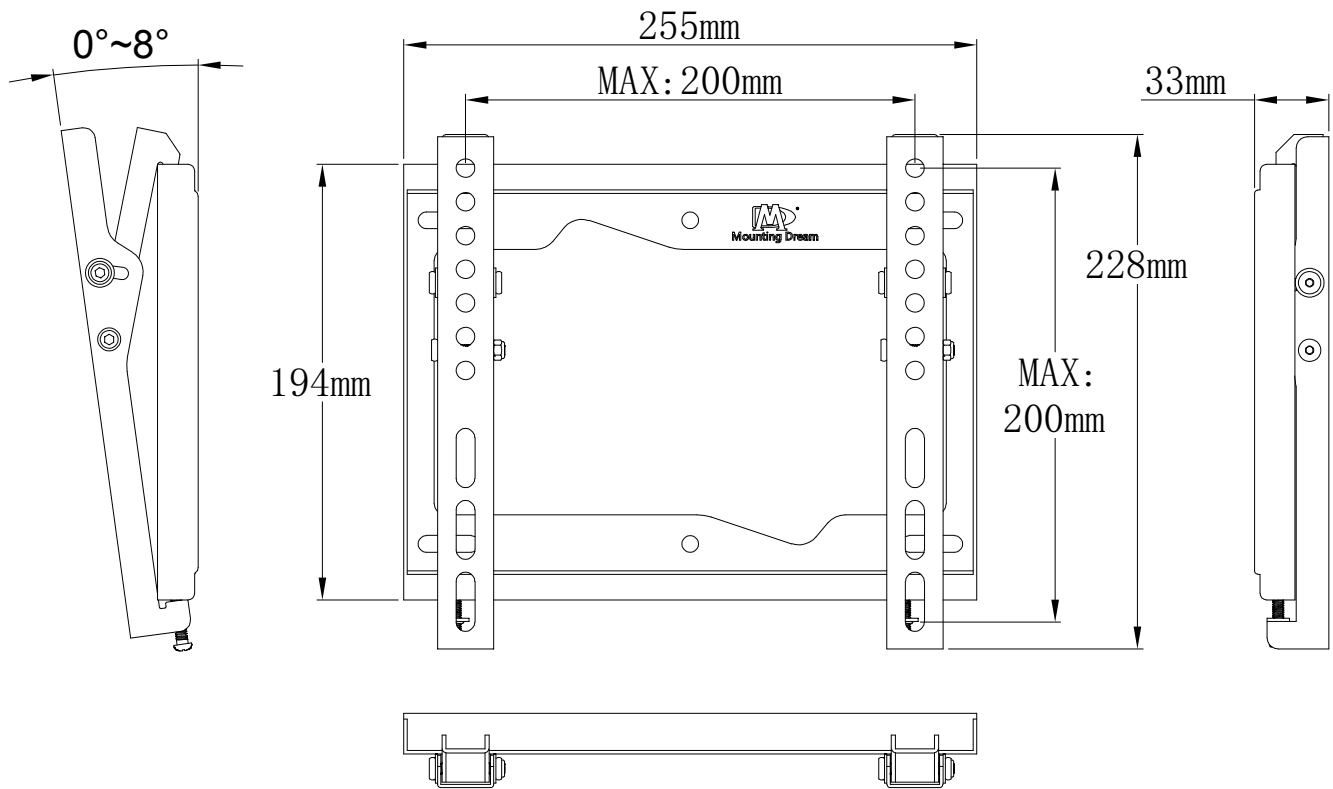

Vor der Installation bestätigen Sie bitte zuerst, ob diese Halterung für Ihr Fernsehapparat geeignet ist!

1 Ist der Abstand der Montagelöcher von Ihrem Fernsehapparat zwischen 75x75mm/3x3" und 200x200mm/8x8"?

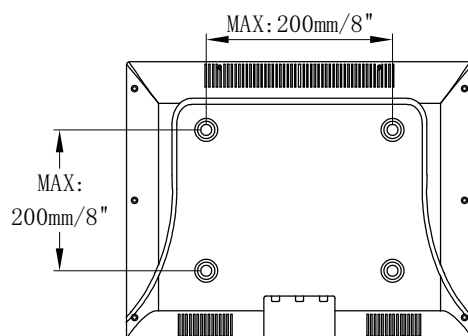

Ja - Perfekt!

Nein - Diese Halterung ist nicht geeignet!

2 Wiegt Ihr Fernsehapparat (inkl. Zubehör) weniger als 20 kg (44 LBS)?



Ja - Perfekt!

Nein - Diese Halterung ist nicht geeignet!

3 Woraus besteht Ihre Wand?

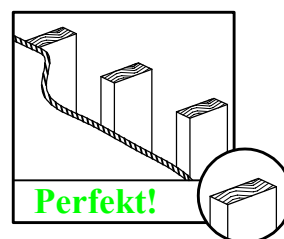

Gipskartonwand mit Holzbalken?

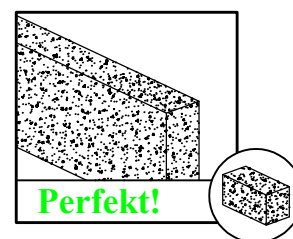

Massivbetonwand?

4 Werkzeuge für Installation (Nicht enthalten)

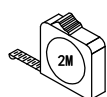

Bandmaß



Bleistift



Kreuzschlitzschraubendreher

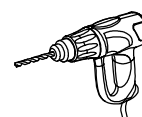

Elektrobohrer

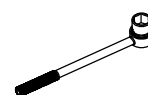

Steckschlüssel (13mm, 1/2")

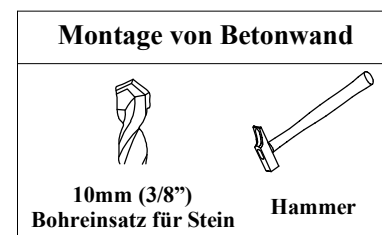
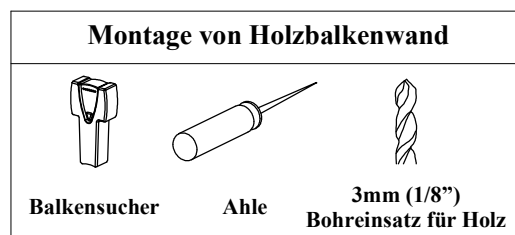

Bitte lesen Sie die Anweisungen sorgfältig vor der Installation durch.

5 Sicherheitshinweise

- Dieses Produkt ist für die Installation an Wänden mit Holzträgern und Massivbetonwand - NICHT an einer reinen Gipskartonwand montieren.
- Die Wand muss das Fünffache des Gesamtgewichts des Fernsehapparats und der Halterung tragen können.
- Verwenden Sie dieses Produkt nicht für einen anderen Zweck als speziell von Mounting Dream angegeben.
- Unsachgemäße Montage dieses Produkts kann zu Verletzungen und zu den Beschädigungen an Ihrem Gerät führen. Mounting Dream haftet nicht für Schäden oder Verletzungen, die durch unsachgemäße Montage, unsachgemäßen Zusammenbau oder unsachgemäße Verwendung verursacht wurden.

⚠️ Warnung: Dieses Produkt enthält kleine Teile, die beim Verschlucken zur Erstickungsgefahr führen können. Bevor Sie mit der Installation beginnen, überprüfen Sie bitte, ob alle Zubehörteile und Ersatzteile vollständig und unbeschädigt sind.

Hinweis: Es wird nicht das gesamte mitgelieferte Befestigungsmaterial verwendet.

Schritt 1 Befestigen Sie die Schienen am Fernseher Siehe Seite 2

Mitgelieferte Teile und Befestigungsmaterialien

1-1 Wählen Sie Schrauben für den Fernseher aus

1-2 Abstandhalter?

I Wenn ja, siehe Seite 3, Kombination **I**.

II Wenn nein, siehe Seite 3, Kombination **II**.

Tipps: Es wird dringend empfohlen, Abstandhalter hinzuzufügen, um den Abstand zwischen der Wandhalterung und der Wand zu vergrößern.

1-3 Befestigen Sie die Fernseher-Schienen

Tipps: Bei der Verwendung von M6(e) / M8(c / f) Schrauben, wenn dabei ein Abstandhalter (j) von 2,5mm gleichzeitig gebraucht wird, entfernen Sie dabei bitte den eingebauten Ring.

Schritt 2 Befestigen Sie die Wandplatte an der Wand

Mitgelieferte Teile und Befestigungsmaterialien

Schritt 2A Die Montage von Holzbalkenwand Siehe Seite 4

⚠️ Vorsicht: Verwenden Sie keinen Dübel, wenn Sie eine Wandplatte an einer Holzbalkenwand installieren!

⚠️ Vorsicht: Alle zwei Sechskant-Holzschrauben **01** müssen festgezogen werden, um ein ungewolltes Verrutschen der Wandplatte zu verhindern. Achten Sie darauf, dass die Wandplatte sicher an der Wand befestigt ist, bevor Sie mit dem nächsten Schritt anfangen. Fahren Sie bitte nach diesem Schritt mit 3. Schritt auf der Seite 7 fort.

Schritt 2B Die Montage von Massivbetonwand Siehe Seite 6

⚠️ Vorsicht: Alle vier Sechskant-Holzschrauben **01** müssen festgezogen werden, um ein ungewolltes Verrutschen der Wandplatte zu verhindern. Achten Sie darauf, dass die Wandplatte sicher an der Wand befestigt ist, bevor Sie mit dem nächsten Schritt anfangen.

Schritt 3 Hängen und befestigen Sie den Fernseher an der Wandplatte Siehe Seite 7

Bevor Sie den Fernseher an die Wandplatte hängen, führen Sie bitte eine Sicherheitsprüfung für die Montage der Wandplatte aus.

* Aus Sicherheitsgründen wird dieser Schritt am besten von zwei Personen gemeinsam ausgeführt.

Schritt 4 Funktionseinstellung Siehe Seite 8

Neigungseinstellung (0°/-8°)

Verwenden Sie einen Inbusschlüssel **02** und lösen Sie die beiden Kippschrauben gegen den Uhrzeigersinn, stellen Sie das Fernsehgerät auf den gewünschten Winkel ein und ziehen Sie die Schrauben mit einem Schraubenschlüssel im Uhrzeigersinn fest.

Schritt 5 Nehmen Sie den Fernseher von der Wandhalterung ab Siehe Seite 8

Produktabmessung Siehe Seite 9

Avant l'installation, veuillez assurer que ce support est adapté à votre téléviseur ou pas !

1 Est-ce que la distance entre des trous de montage de votre téléviseur est plus de ou égale à 75x75mm/3x3" et moins de ou égale à 200x200mm/8x8"?

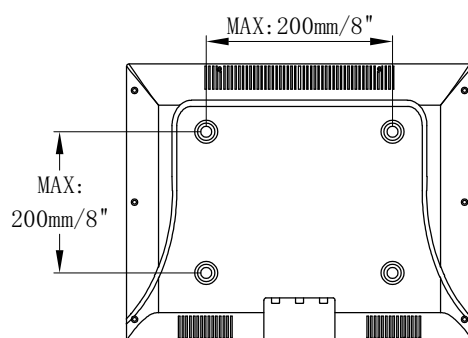

Oui - Parfait !

Non - Ce support ne vous convient pas !

2 Est-ce que votre téléviseur et des autres accessoires pèsent totalement moins de 20 kg (44 LBS)?



Oui - Parfait !

Non - Ce support ne vous convient pas !

3 De quels genres matériaux le mur est fait ?

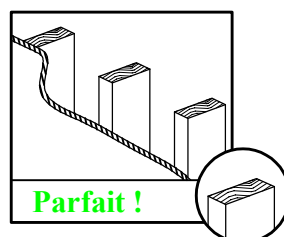
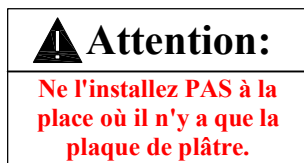

Cloison sèche avec montant en bois ?

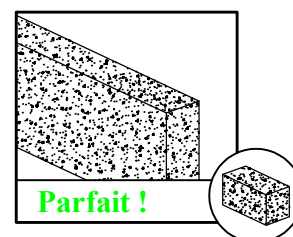

Mur en béton plein ?

4 Outils d'installation (Pas inclus)

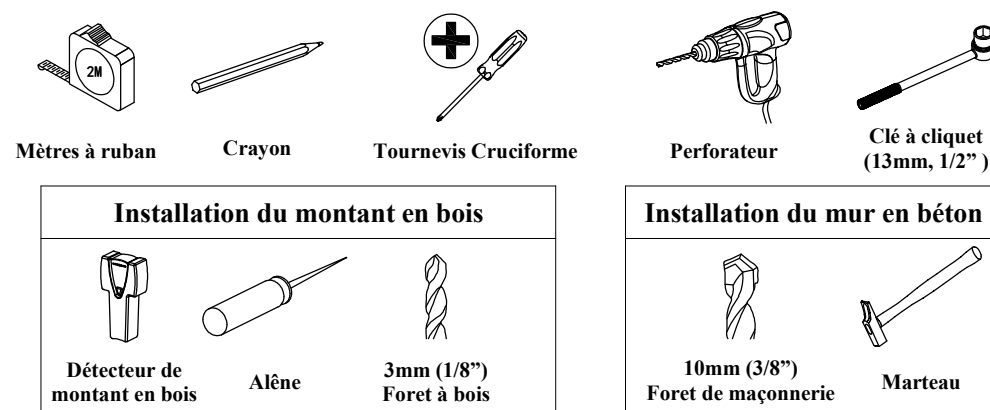

5 Consignes de sécurité

Avant l'installation, veuillez attentivement lire ce mode d'emploi.

- Ce produit s'applique au montant en bois, au mur en béton plein - Ne l'installez pas à la place où il n'y a que la plaque de plâtre.
- La force portante du mur doit atteindre au moins cinq fois du poids total de votre téléviseur et du support.
- N'utilisez pas ce produit pour des autres objectifs non désignés par Mounting Dream.
- L'installation incorrecte causera le dommage matériel ou la blessure corporelle. Mounting Dream n'assumera aucune responsabilité pour le dommage et la blessure causés par l'installation incorrecte ou l'utilisation inadéquate.

⚠ AVERTISSEMENT : Ce produit contient des petites pièces, en cas d'ingestion, des risques de suffocation y arrivera. Avant l'installation, veuillez vérifier que tous les accessoires et toutes les pièces sont complets et non défectueux.

ATTENTION : Les pièces fournies ne seront pas toutes utilisées durant l'installation.

Étape 1 Installer des barres verticales sur votre téléviseur Voir à la page 2

Pièces et accessoires

1-1 Choisir des vis de téléviseur

1-2 Entretoises sont nécessaires ?

I Oui, voir à la page 3, combinaison **I**.

II Non, voir à la page 3, combinaison **II**.

Conseils: Fortement recommandé d'ajouter des entretoises pour augmenter la distance entre le support mural du téléviseur et le mur.

1-3 Assembler des barres verticales

Remarque : Quand vous choisissez la vis M6(e) / M8(c / f) et l'entretoise (j) de 2,5mm est nécessaire, veuillez enlever la cerce interne.

Étape 2 Installer la plaque murale au mur

Pièces et accessoires

Étape 2A Installation du montant en bois Voir à la page 4

⚠ Attention : Quand vous installez la plaque murale au mur avec le poteau de bois, n'utilisez pas les chevilles !

⚠ Attention : Tous les quatre boulons tire-fond **01** doivent être fermement serrés pour éviter le mouvement non souhaité de la plaque murale. Veuillez vérifier que la plaque murale est fixée sur le mur avant de passer à l'étape suivante. Après avoir fini cette étape, allez directement à la page 7 et continuez l'étape 3.

Étape 2B Installation du mur en béton plein Voir à la page 6

⚠ Attention : Tous les deux boulons tire-fond **01** doivent être fermement serrés pour éviter le mouvement non souhaité de la plaque murale. Veuillez vérifier que la plaque murale est fixée sur le mur avant de passer à l'étape suivante.

Étape 3 Suspendre et fixer votre téléviseur sur la plaque murale Voir à la page 7

Avant de suspendre votre téléviseur sur la plaque murale, veuillez tester la fiabilité de l'installation de la plaque murale.

* Compte tenu de la sécurité, deux personnes sont nécessaires pour l'installation.

Étape 4 Ajustement de fonction Voir à la page 8

L'ajustement de l'angle d'inclinaison (0°/-8°)

Desserrer à la clé hexagonale **02** les deux vis d'inclinaison, ajuster votre téléviseur à l'angle souhaitée et puis serrer les vis.

Étape 5 Démontez votre téléviseur de la plaque murale Voir à la page 8

Dimensions de produit Voir à la page 9

Antes de comenzar a instalar este soporte mural para tv , favor confirme si es el adecuado para su televisor!

1 Los orificios posteriores de su televisor tienen una distancia mayor o igual a 75x75mm/3x3" y menor o igual a 200x200mm/8x8"?

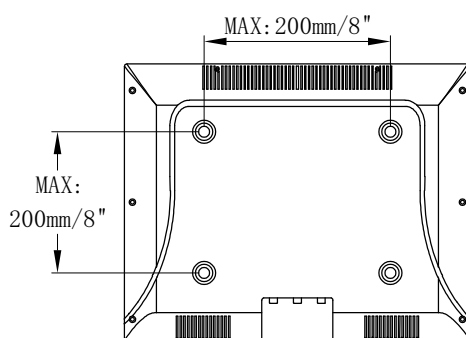

Si - Es el adecuado!

No - Este soporte no es el adecuado!

2 El peso de su televisor y los demás accesorios en total es menor a 20 kg (44 LBS)?



Si - Es el adecuado!

No - Este soporte no es el adecuado!

3 La pared de que material esta construida?

Atención:
En paredes de yeso o derivados no se debe instalar.

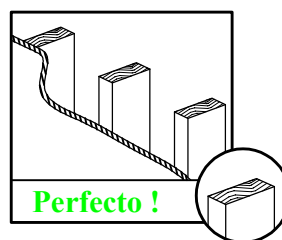

Instalar en paredes con pilares de madera?

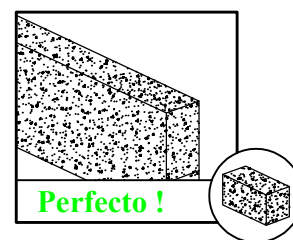

Instalar en paredes de hormigón sólido ?

4 Herramientas necesarias para su instalación (No incluido)

Cinta Métrica	Lápiz	Destornillador de Cruz	Taladro Eléctrico	Juego de llaves (13mm, 1/2")
Instalación en pared con pilares de madera			Instalación en pared de hormigón	
Detector de Madera	Punzón	3mm (1/8") Broca para Madera	10mm (3/8") Broca de Impacto	Martillo

5 Advertencias de seguridad

Antes de la instalación favor de leer en detalle el manual de instrucciones.

- Este producto es apto para paredes con pilares de madera, y muro de hormigón sólido - No instalar en paredes de solo yeso.
- La capacidad de soporte de la pared debe ser cinco veces más que el peso total del televisor y el soporte.
- Favor NO utilizar el producto de Mounting Dream para otros usos no asignados.
- La instalación incorrecta puede producir daños al producto o lesiones al usuario. Cualquier pérdida o daño debido por la mala instalación o uso indebido, Mounting Dream no asume ninguna responsabilidad.

Instrucciones paso a paso de su instalación

⚠ Advertencia: Este producto contiene piezas pequeñas, si por error se ingiere, puede provocar peligro de asfixia. Antes de comenzar la instalación, favor compruebe que todos los accesorios y piezas de repuesto estén completas y sin daño alguno.

Atención: No todas las piezas se utilizarán.

Paso 1 Instalar las varillas del soportes al televisor Ver página 2

Accesorios y piezas

1-1 Elegir los tornillos para el televisor

1-2 Necesito espaciadores?

I Necesito, favor ver la combinación **I** en la página 3.

II No necesito, favor ver la combinación **II** en la página 3.

Tips: Muy recomendable agregar espaciadores para aumentar la distancia entre el soporte de pared del televisor y la pared.

1-3 Instalar las varillas del soporte

Tips: Si necesita espaciadores de 2,5mm (j) combinados con tornillos de M6(e) / M8(c / f), favor retirar la argolla/anillo.

Paso 2 Instalar la placa mural

Accesorios y piezas

Paso 2A Instalación en pared con pilares de madera Ver página 4

⚠ Atención: Al momento de instalar el panel en la pared con pilares de madera, favor no usar los tacos/tarugos para la pared de hormigón!

⚠ Atención: Los cuatro tornillos **01** de cabeza hexagonal deben apretarse firmemente, para evitar que la placa mural en la pared se mueva. Favor de asegurarse que quede firmemente estable en la pared para poder continuar con los siguientes pasos de la instalación. Luego de terminar este paso favor continuar con el paso 3 en la página 7.

Paso 2B Instalación en pared de hormigón sólido Ver página 6

⚠ Atención: Los dos tornillos **01** de cabeza hexagonal deben apretarse firmemente, para evitar que la placa mural en la pared se mueva. Favor de asegurarse que quede firmemente estable en la pared para poder continuar con los siguientes pasos de su instalación.

Paso 3 Colgar y sujetar del televisor a la placa mural Ver página 7

Antes de colgar el televisor en la placa mural, favor realizar una prueba de confiabilidad a la instalación.

* Por razones de seguridad, para concluir este paso es mejor hacerlo en compañía de otra persona.

Paso 4 Funciones de regulación Ver página 8

Regulación del ángulo de inclinación (0°/-8°)

Use una llave hexagonal **02** y afloje los 2 tornillos de inclinación, ajuste su televisor al ángulo deseado, y luego vuelva a apretar los tornillos.

Paso 5 Quitar el televisor del soporte mural Ver página 8

Dimensiones del producto Ver página 9

Prima di iniziare l'installazione, per prima cosa conferma se questo Supporto è ideale per la vostra TV!

1 La distanza dei fori di installazione TV sono superiore/uguale a 75x75mm/3x3" e inferiore /uguale a 200x200mm/8x8"?

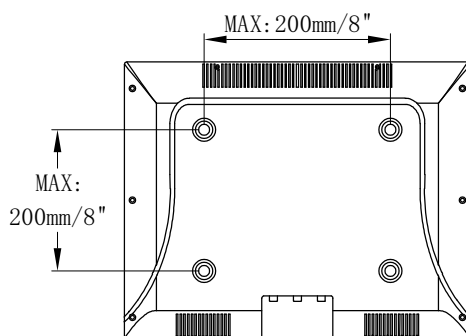

Sì - Ideale!

No - Questo supporto non va!

2 Il tuo televisore (inclusi accessori) pesa totalmente inferiore a 20 kg (44 LBS)?



Sì - Ideale!

No - Questo supporto non va!

3 Di che materiale è fatto il muro?

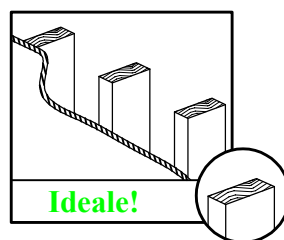

Muro secco con i pilastri in legno?

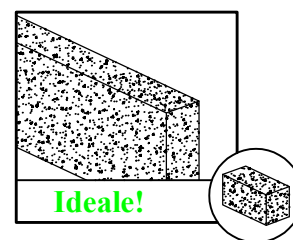

Muro in calcestruzzo solido ?

4 Utensili per installazione (Non incluso)

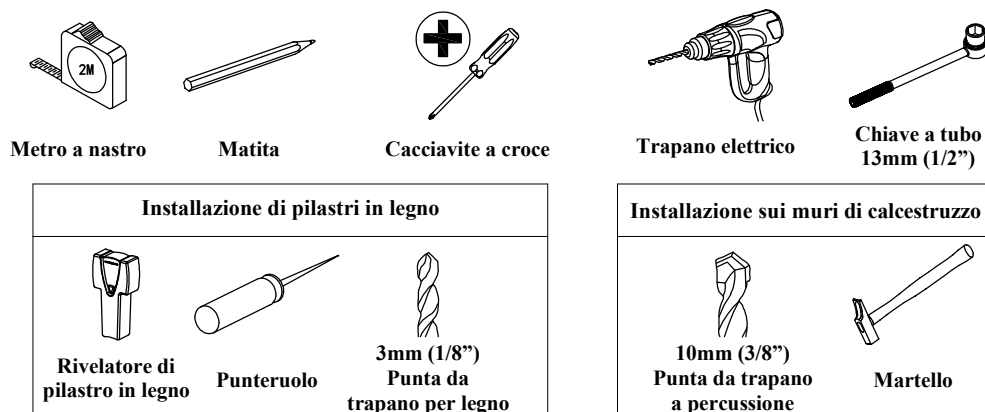

Leggi attentamente le istruzioni prima di installazione.

5 Cautele per sicurezza

- Questo prodotto è progettato per pilastri in legno e muri in calcestruzzo solido - NON installarlo in soli cartongessi.
- Il muro deve essere capace di portare almeno cinque volte il peso totale del televisore e del supporto.
- Non applicare questo prodotto ad altri scopi non indicati da Mounting Dream.
- L'installazione errata potrebbe causare danni al prodotto o lesioni personali. Mounting Dream non si assume alcuna responsabilità per danni o lesioni causate da installazione impropria o uso improprio.



Istruzioni di installazione

⚠ Avvertenza: Questo prodotto contiene piccoli articoli che potrebbe causare il pericolo di soffocamento se ingoiati.

Nota: Non verranno utilizzati tutte le parti incluse.

Passo 1 Installa barre verticali al televisore Vedi pagina 2

Accessori e parti

1-1 Seleziona viti TV

1-2 Si ha bisogno di pilastri con guarnizione?

I Sì, vedi la combinazione **I** nella pagina 3.

II No, vedi la combinazione **II** nella pagina 3.

Suggerimenti: si consiglia vivamente di aggiungere pilastri per aumentare la distanza tra la il supporto a parete per TV e il muro.

1-3 Installazione di barre verticali

Suggerimento: se è necessario combinare il pilastro con guarnizione 2,5mm (j) con la vite M6(e) / M8(c / f), rimuovi l'anello interno.

Passo 2 Installa la piastra a muro sul muro

Accessori e parti

Passo 2A Installazione sul muro con i pilastri in legno Vedi pagina 4

⚠ Cautela: Quando si installa la piastra a muro sul muro con pilastri in legno, non utilizzare i tasselli per il muro in calcestruzzo!

⚠ Cautela: Le quattro viti **01** per Legno a testa esagonale devono essere avvitate bene in modo da evitare movimenti indesiderati della piastra a muro. Assicura che la piastra a muro sia ben fissate sul muro prima di eseguire il prossimo passo. Dopo finire questo passo, va direttamente alla pagina 7 per il passo 3.

Passo 2B Installazione sul muro in calcestruzzo Vedi pagina 6

⚠ Cautela: Le due viti **01** per Legno a testa esagonale devono essere avvitate bene in modo da evitare movimenti indesiderati della piastra a muro. Assicura che la piastra a muro sia ben fissata sul muro prima di eseguire il prossimo passo.

Passo 3 Appendi e fissa la TV alla piastra a muro Vedi pagina 7

Prima di appendere la TV alla piastra a muro, esegui un test di affidabilità dell'installazione della piastra a muro.

* Per la sicurezza, è meglio eseguire questo passo da due persone.

Passo 4 Regolazioni di funzione Vedi pagina 8

Regolazione dell'angolo di inclinazione (0°/-8°)

Allenta due viti di inclinazione con la chiave a brugola interna **02**, regola la TV all'angolo desiderato, quindi avvita le viti con chiave a brugola interna.

Passo 5 Togli la TV dalla piastra a muro Vedi pagina 8

Dimensioni del prodotto Vedi pagina 9