



Mounting Dream

MD2198 INSTALLATION INSTRUCTION

Für die Installationsanweisungen auf Deutsch, siehe Seite 10~11.

Pour l'instruction en Français, veuillez vous reporter à la page 12~13.

Para las instrucciones de la instalación en Español, favor vea la página 14~15.

Per le Istruzioni in Italiano, vedi pagina 16~17.

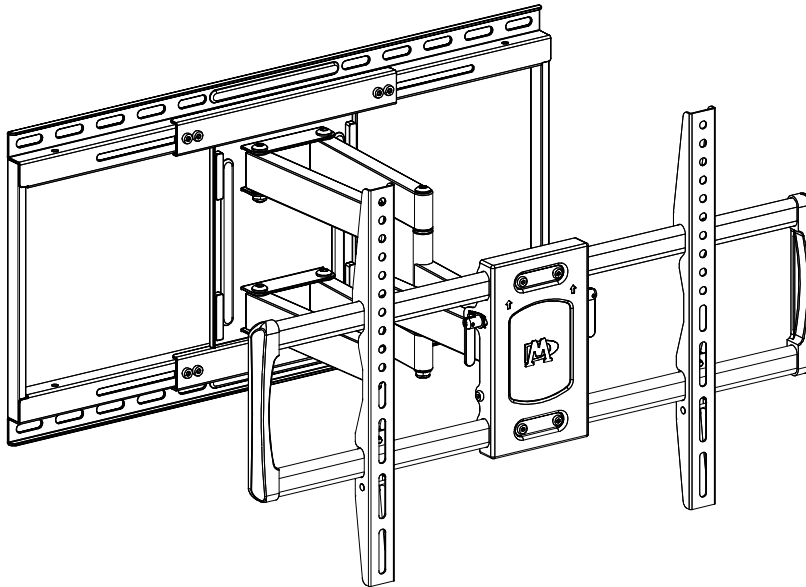

Mounting Dream

x3

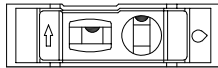

x1

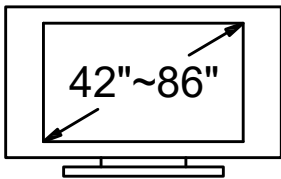

Max:600x400mm/24x16"
Min:200x100mm/8x4"

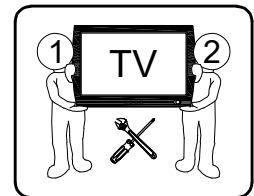

(C1)

Before getting started, let's make sure this mount is perfect for you!

1 Is your TV VESA equal to/greater than 200x100mm/8x4" and equal to/less than 600x400mm/24x16"?

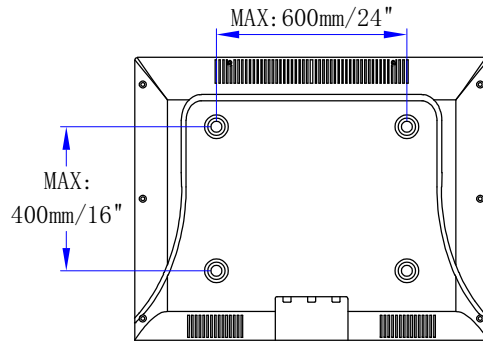

Yes --- Perfect!

No --- This mount is **NOT** compatible.

2 Does your TV (including accessories) weigh less than 132 LBS (60 KG)?



Yes --- Perfect!

No --- This mount is **NOT** compatible.

3 What is your wall made of?

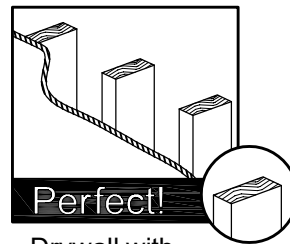

Drywall with wood studs?

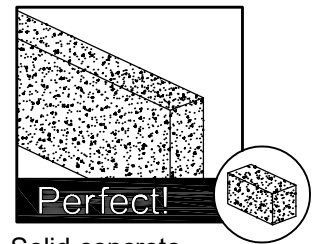

Solid concrete wall?

4 Installation Tools (Not Included)

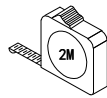

Band Tape



Pencil



Screwdriver

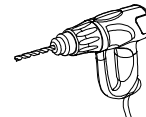

Electrodrill

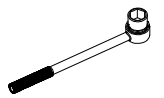

Socket Wrench 1/2"(13mm)

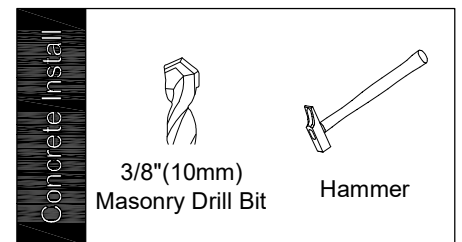
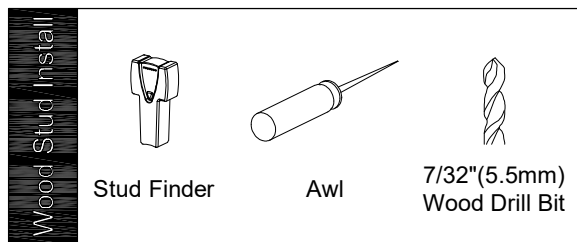

5 Safety Caution

Please read this instruction carefully before installation.

- This product is designed for use in wood stud and solid concrete wall.
 - DO NOT install into drywall alone.
- The wall must be capable of supporting five times the weight of the TV and mount combined.
- Do not apply this product to any purpose not indicated by Mounting Dream.
- Incorrect installation may result in product damage or body injury. Mounting Dream shall bear no responsibility for any damage or injury resulted from incorrect installation, incorrect assembly or misuse.

STEP 1 Attach Brackets to TV

Parts and Hardware

WARNING: This product contains small items that could be a choking hazard if swallowed. Before starting assembly, verify all parts are included and undamaged.

NOTE: Not all hardware included will be used.

TV Screws

M4x12mm

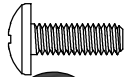

a x4

M4x30mm



d x4

M6x12mm

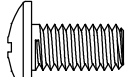

b x4

M6x35mm

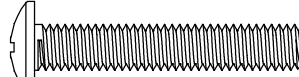

e x4

M8x25mm

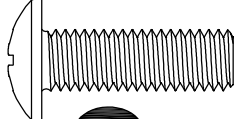

c x4

M8x45mm

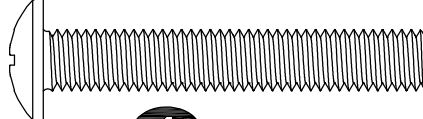

f x4

Spacers

M6x17mm

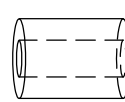

g x4

M8x22mm

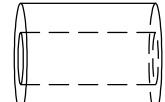

h x4

M8x10mm

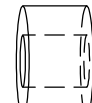

i x8

M8x2.5mm



j x4

Washers

M4



k x4

M6

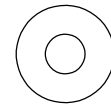

l x4

Wall mounting and TV bracket assembly hardware

Lag Bolt M8x60mm

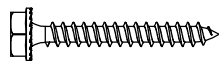

01 x4

Allen Key

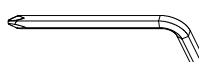

02 x1

M6x16mm Bolt



03 x2

Wall Plate Unit

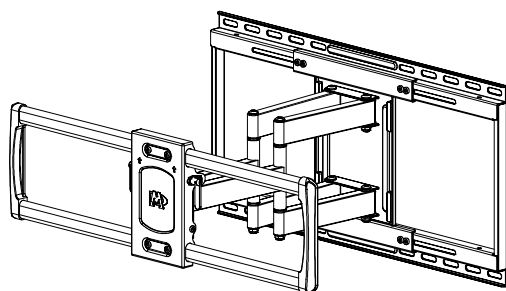

04 x1

Part List

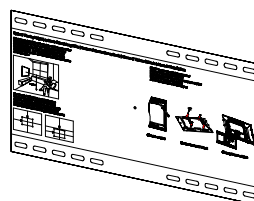

Mounting
Template

TV bracket



05 x2

STEP 1 Attach Brackets to TV

1-1 Select TV Screws

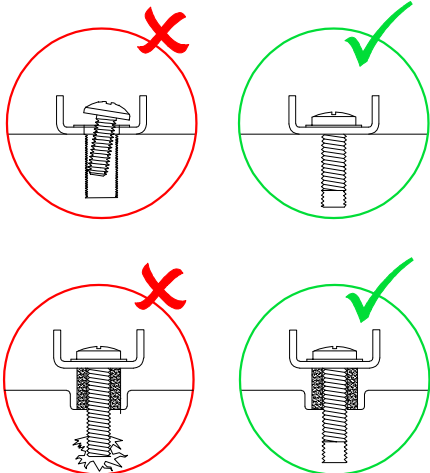
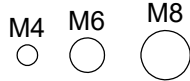
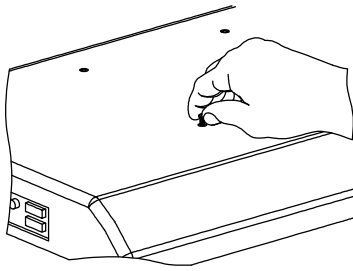

1-2 Need Spacer?

I No, go to PAGE 3 **I** for detailed combination.

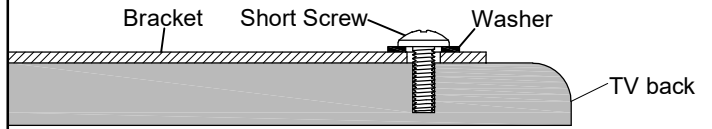

II Yes, go to PAGE 3 **II** for detailed combination.

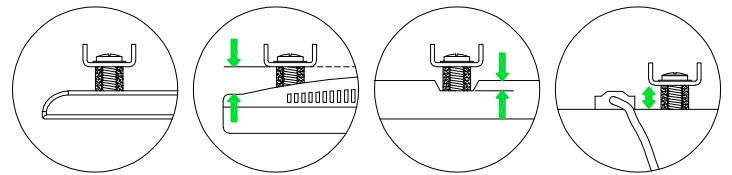
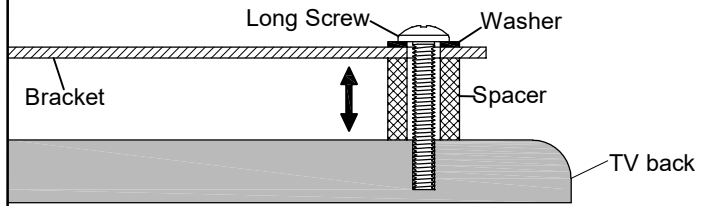

1-3 Attach the TV Brackets

NOTE: Choose proper washer or spacer that fits your particular TV mounting holes.

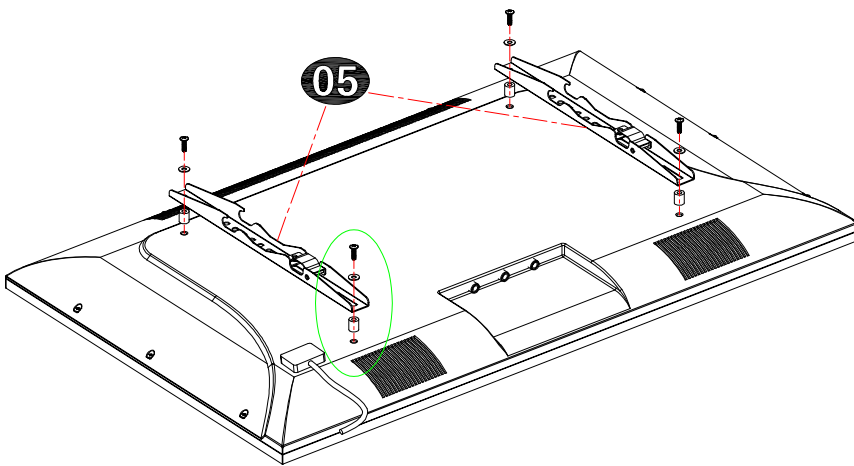

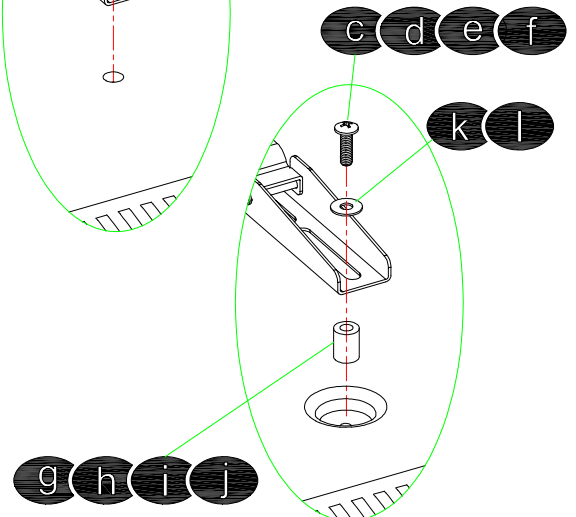
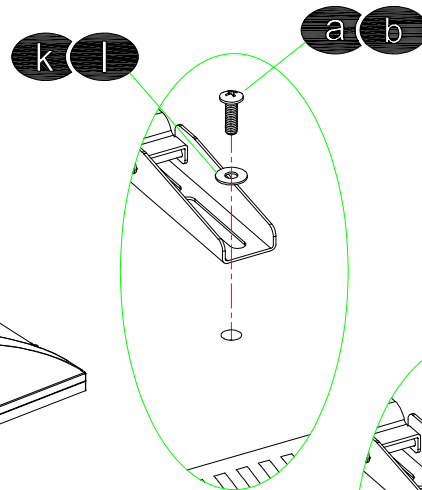

I Screw and washer



Tips: If you need to combine M6(e) or M8(c/f) screw with 2.5mm spacer(j), you have to remove the inner circle.

II Spacer(s) screw and washer

STEP 2 Attach Wall Plate to Wall

-  For wood stud installation, follow STEP 2A
-  For concrete installation, follow STEP 2B on PAGE 9

STEP 2A Wood Stud Installations

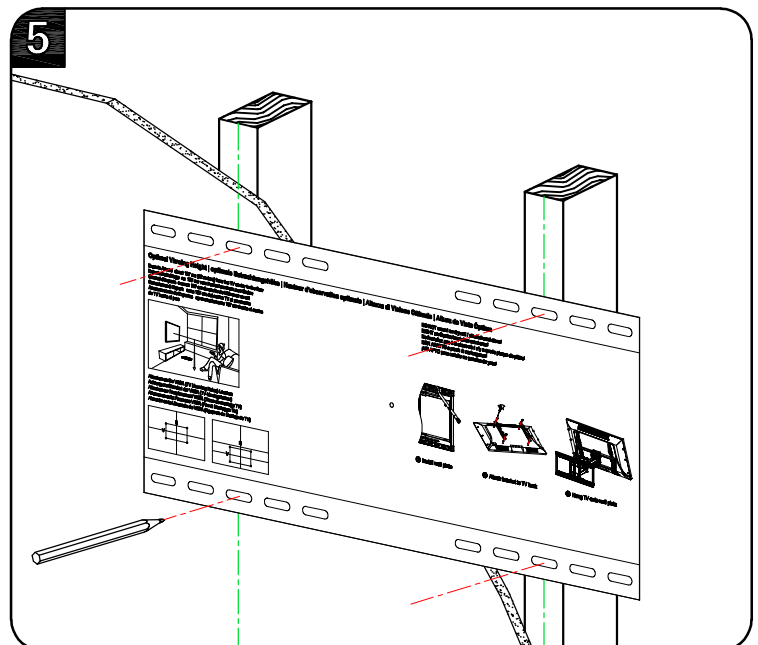
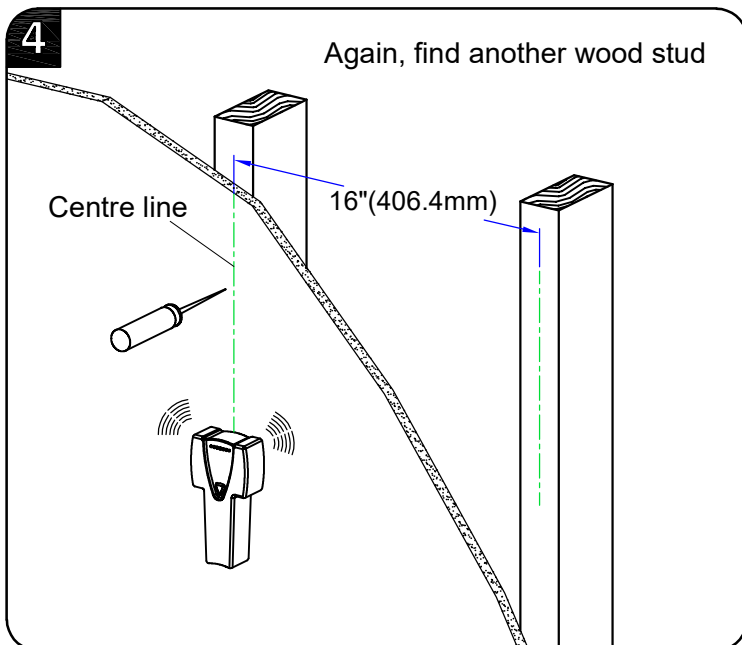
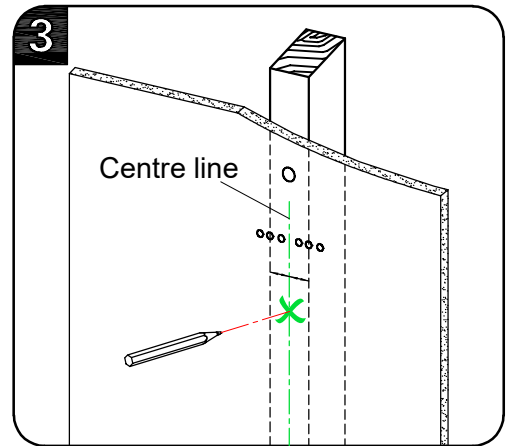
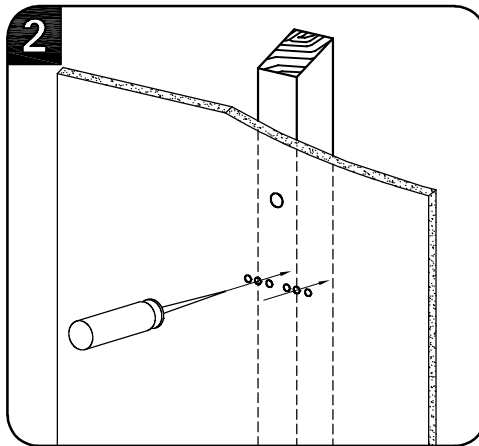
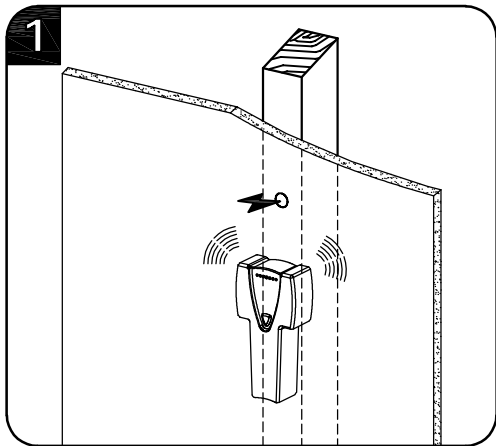
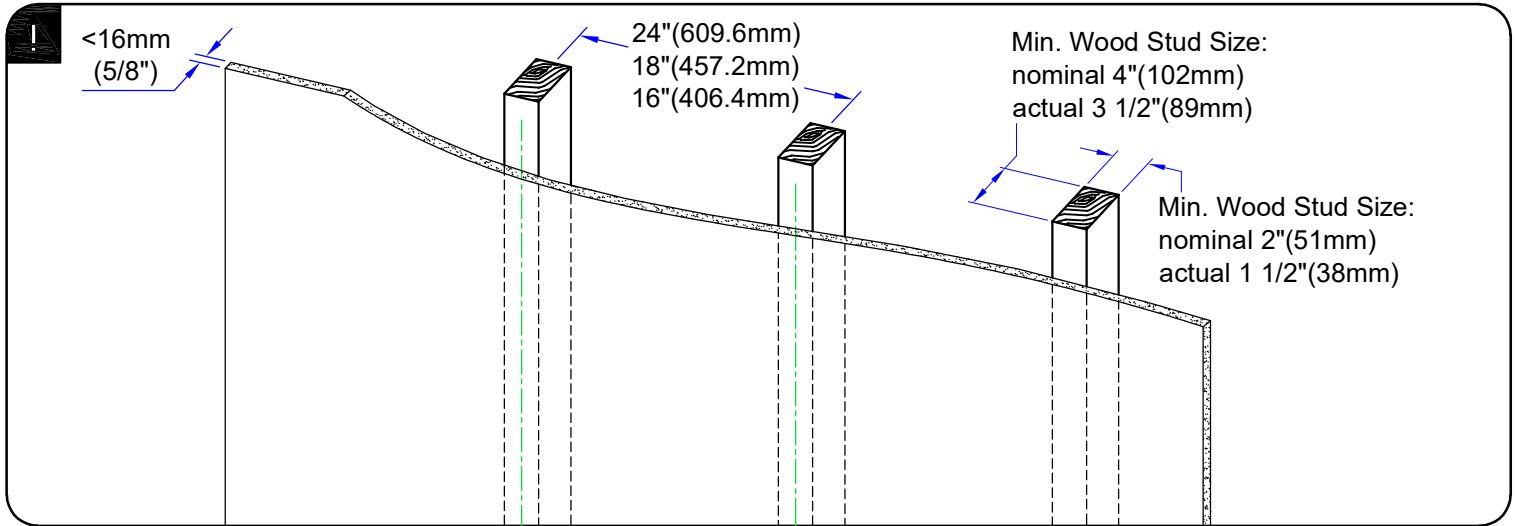

⚠ CAUTION: To avoid potential personal injury or property damage:
 All 4 lag bolts **01** MUST BE firmly tightened to prevent unwanted movement of the wall plate assembly. Ensure the wall plate assembly is securely fastened to the wall before continuing on to the next step.
 To prevent the TV falling down, the direction of the arrow should be upward as shown.

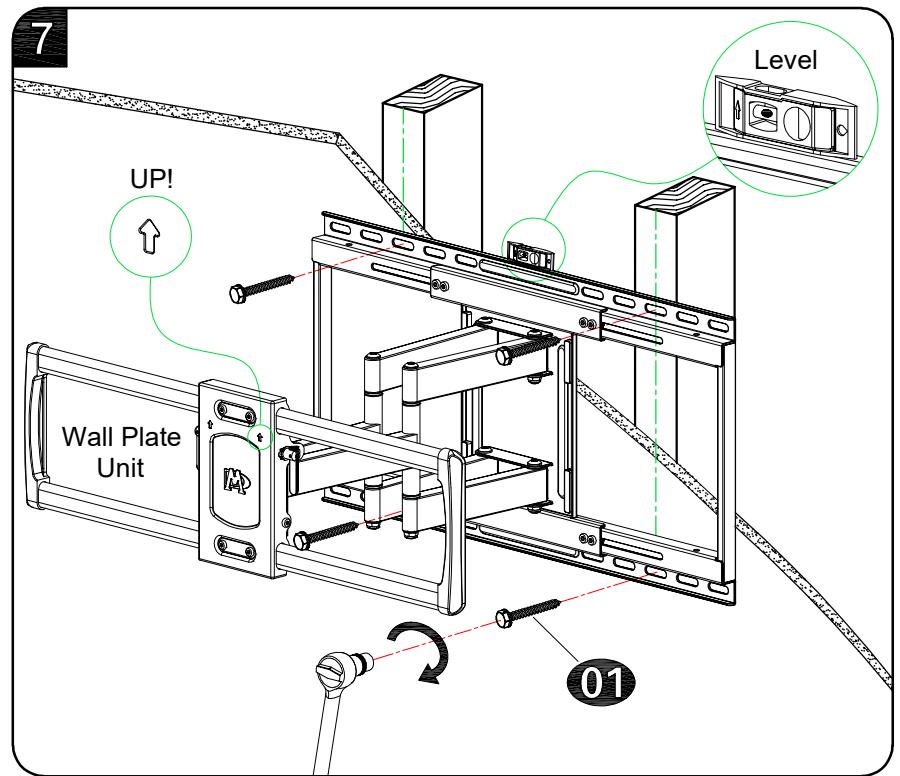
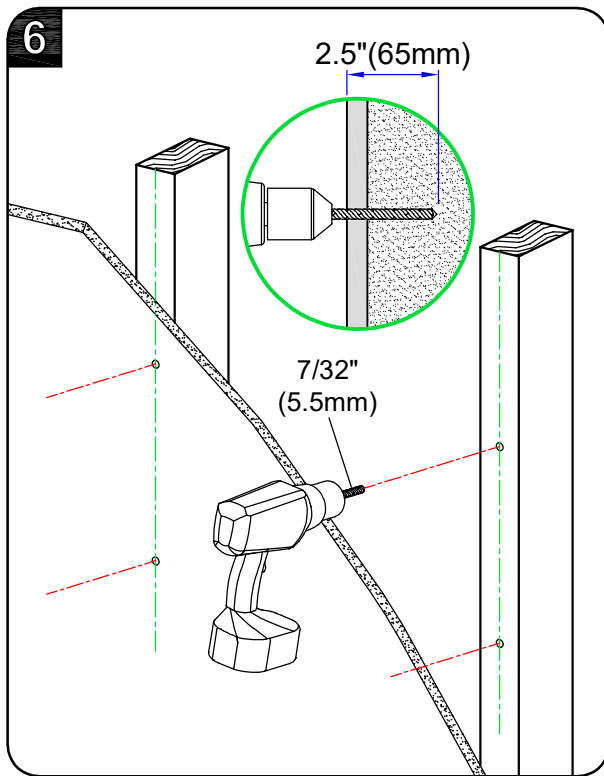

STEP 3 Hang and Secure TV to Wall Plate

3-1 Wall Plate Installation Integrity Test

Before hanging TV, please conduct "wall plate installation integrity test" first.

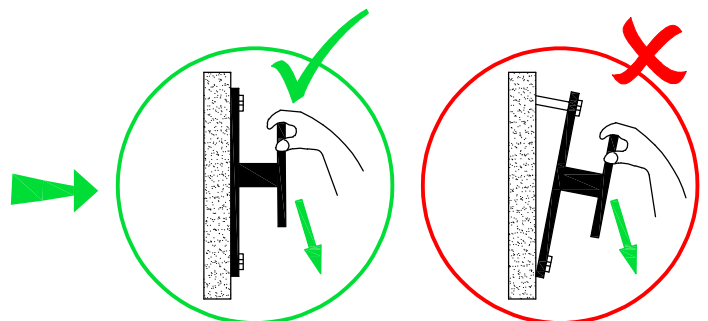
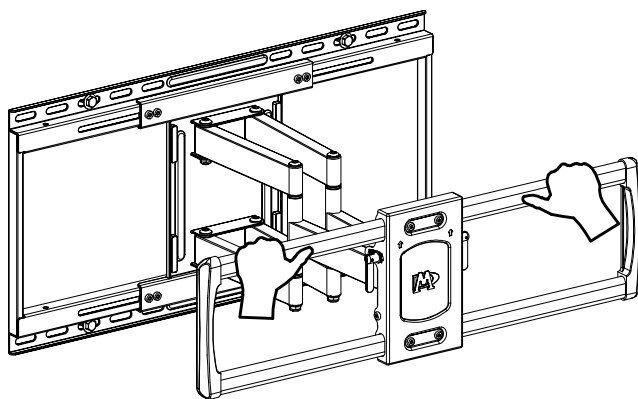

132 LBS (60 KG)

3-2 Hang and Secure TV to Wall Plate

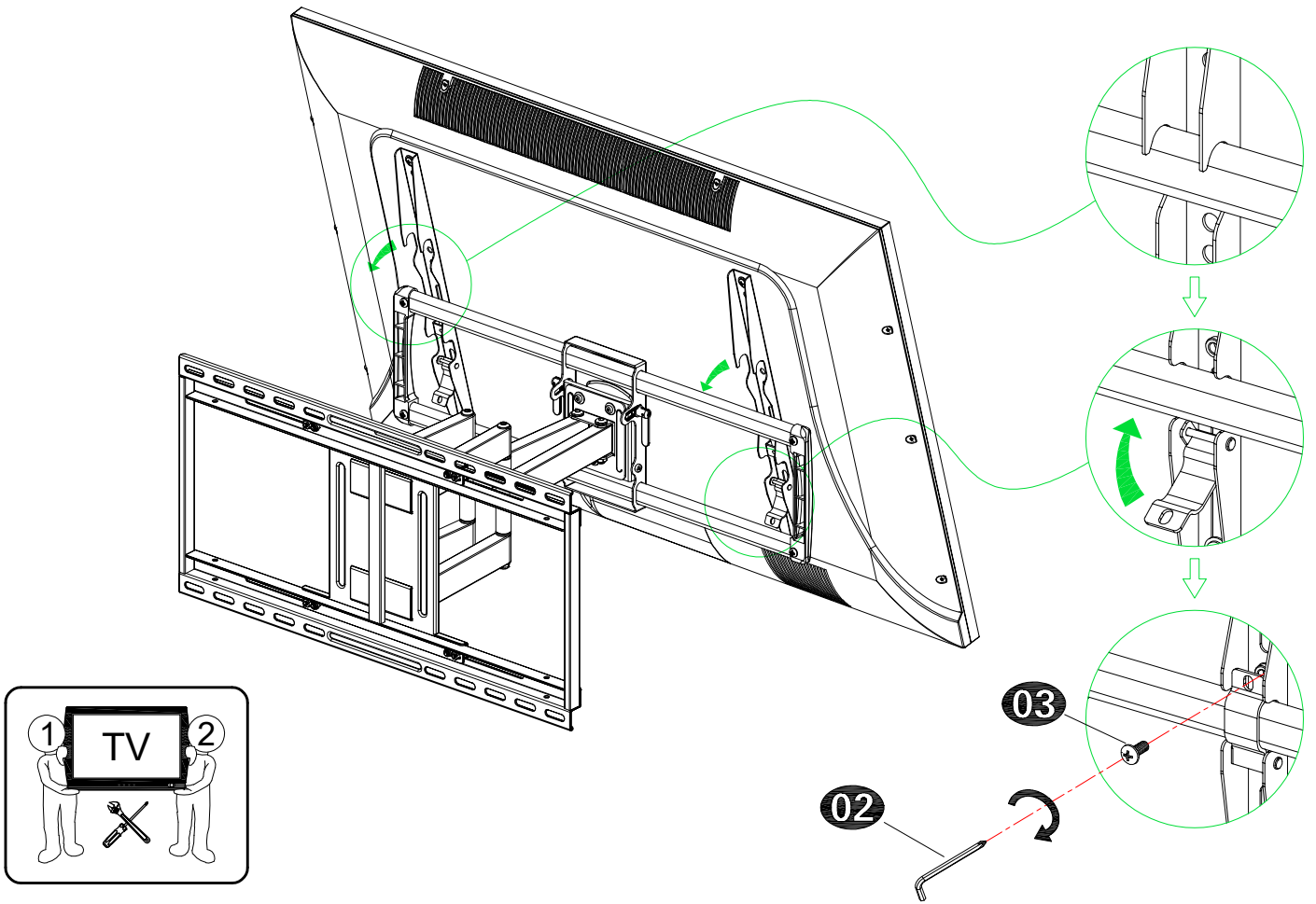

STEP 4 Adjustments

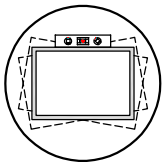

4-1 TV leveling adjustment ($\pm 3^\circ$):
Loosen 2 leveling bolts on the rear of TV plate by maximum 2 turns, adjust to level, and retighten to secure.

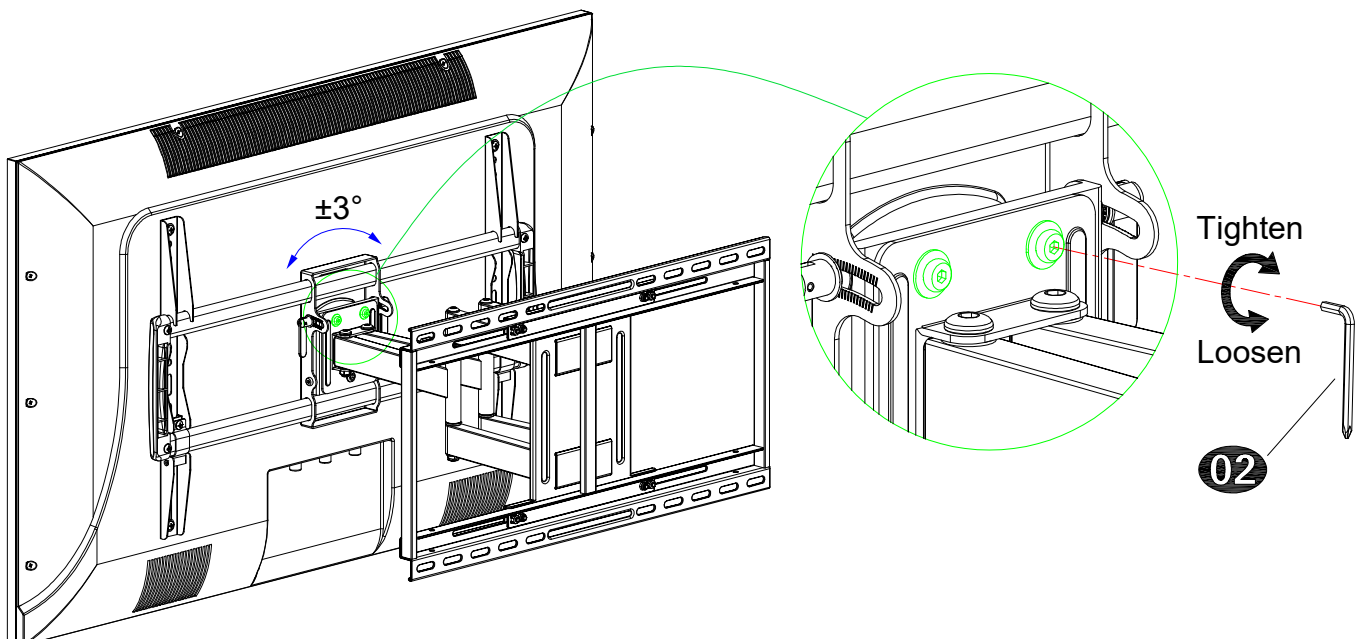

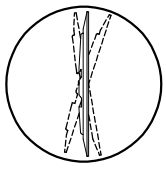

4-2 Tilting angle adjustment (+5°/-15°):
Loosen handle, adjust TV to your desired position,
then tighten handle.

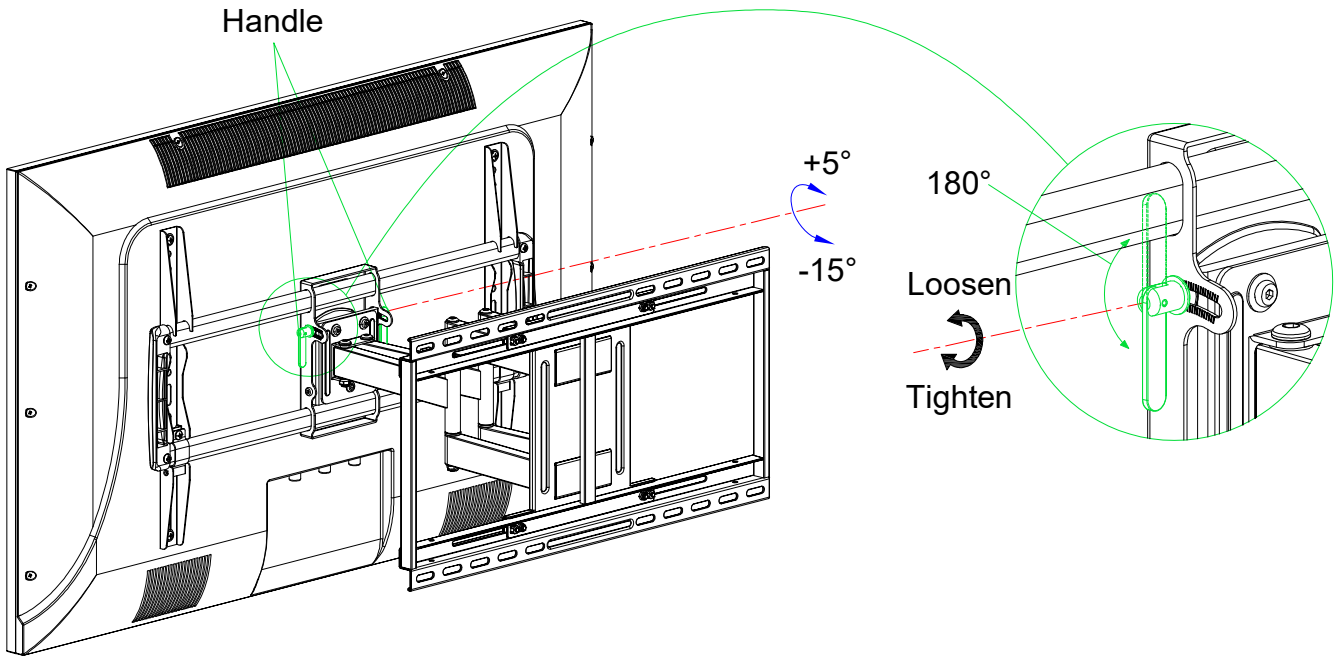

4-3 TV side to side movement 8":

Loosen four bolts by maximum 2 turns and need two people cooperation to lift the assembly unit (TV + TV plate + arms) at the same time slide it left or right along the rail of the wall plate to perfectly position the TV. Then tighten the bolts after adjustment.

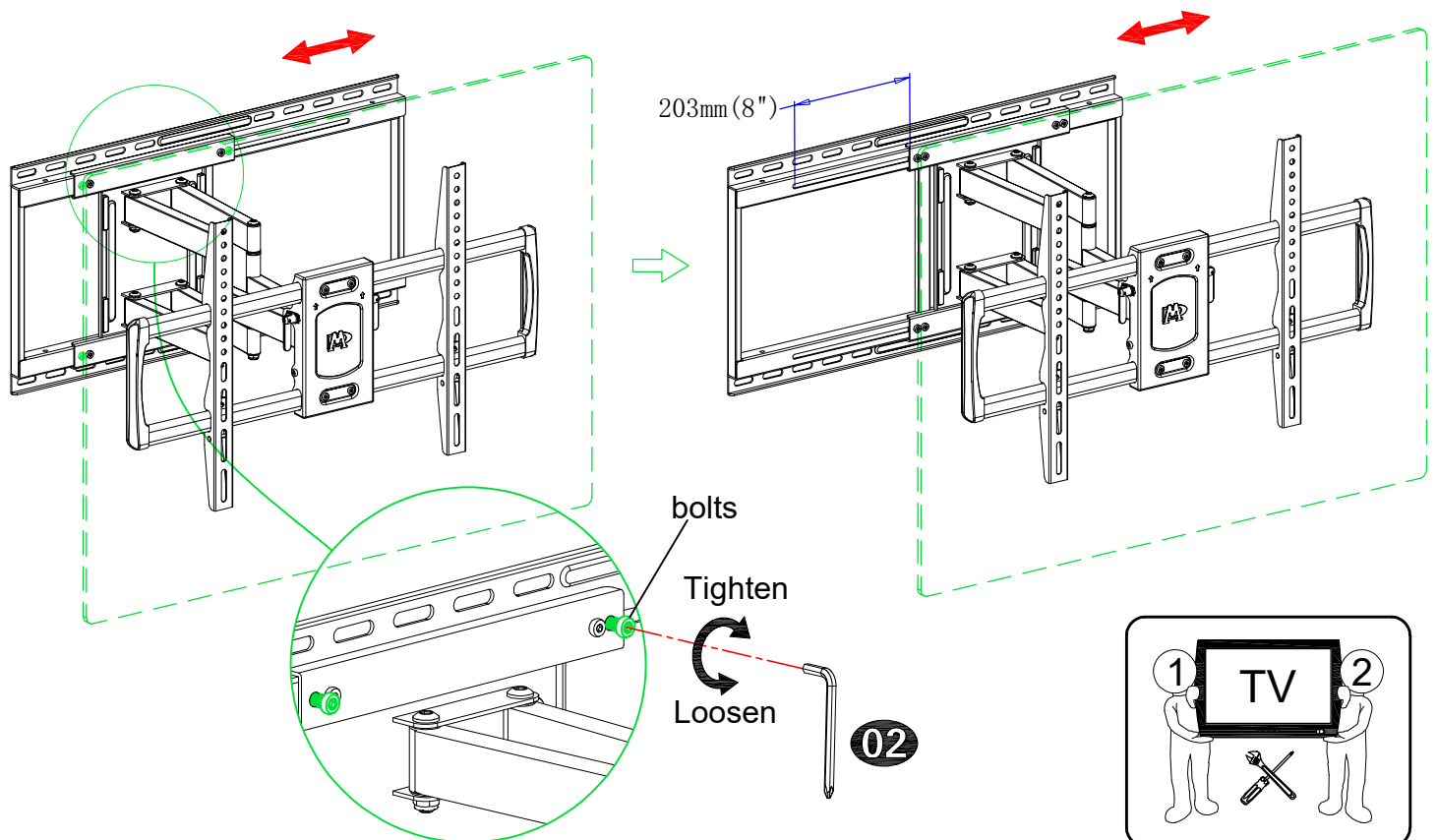



Allen key storage: For easy adjustment, you might put the Allen key on the wall plate as illustration.

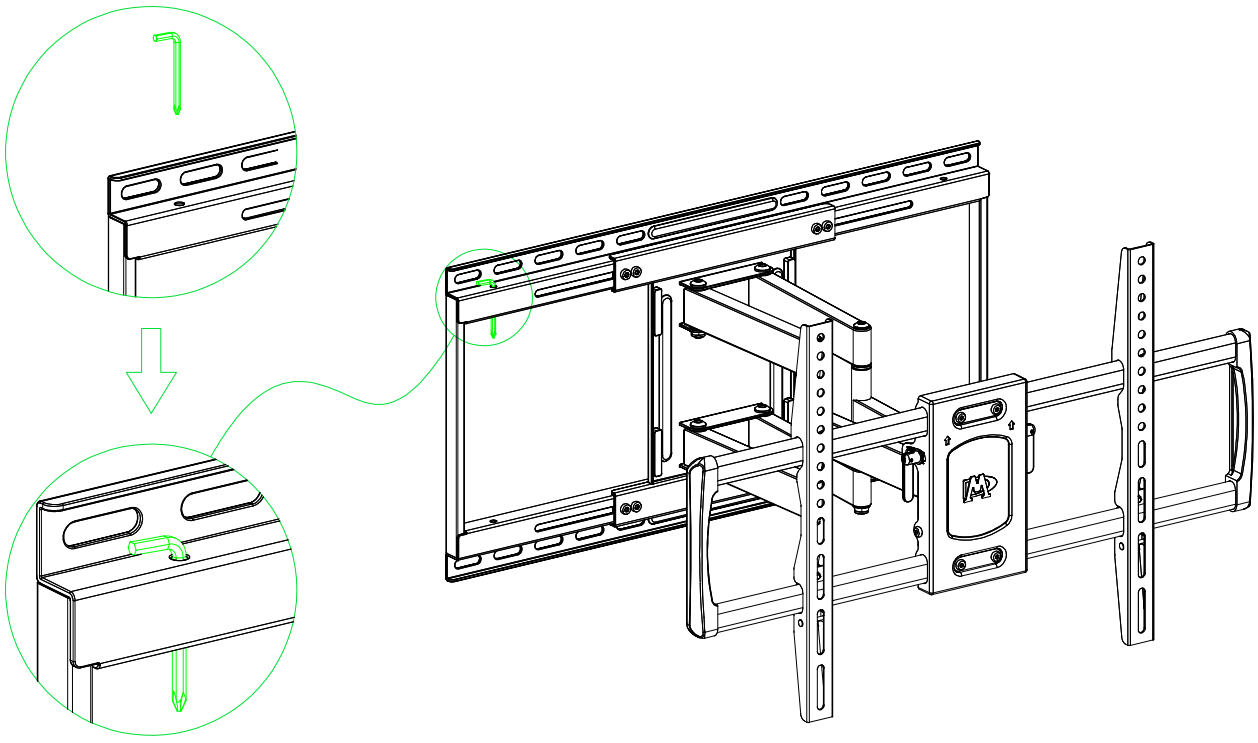

Product dimensions:

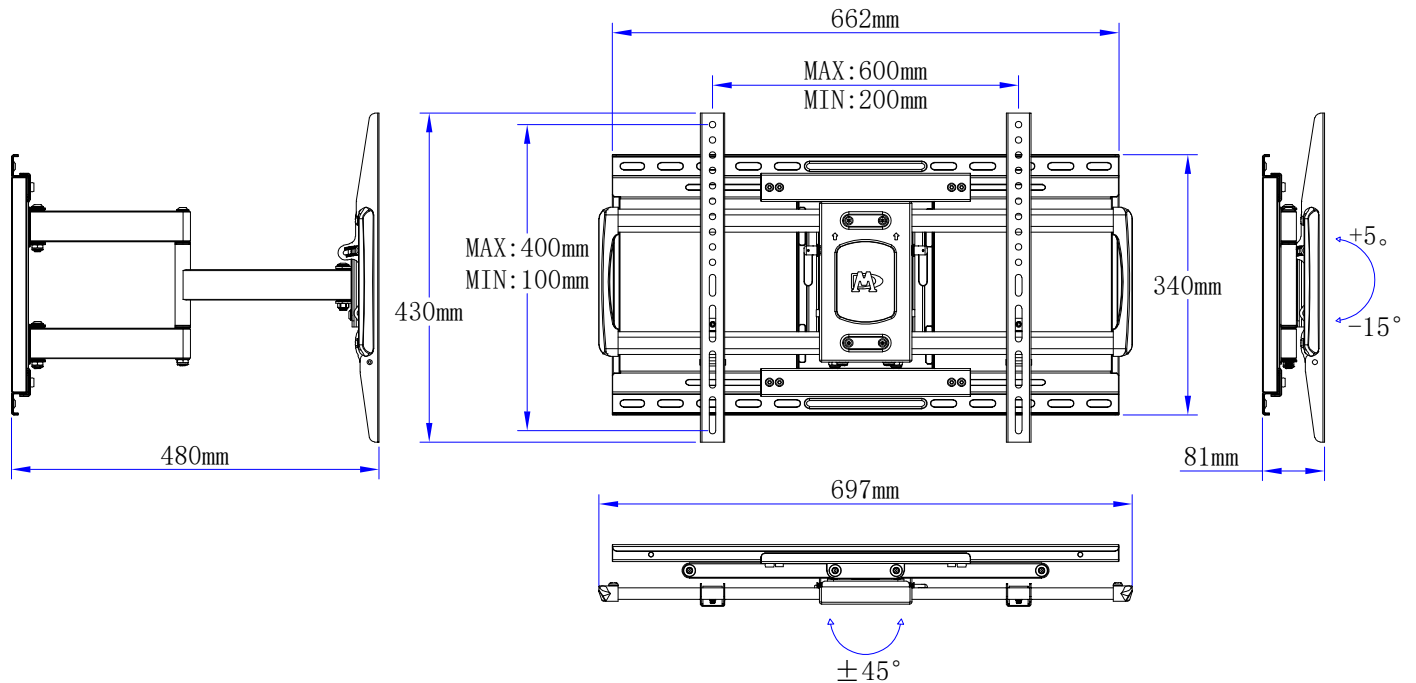

STEP 2B

Solid Concrete Wall Installation

Concrete wall anchor (NOT INCLUDED)



Concrete Wall Anchor
4pcs

If you do need concrete anchor,
please contact us Via Amazon to
get it.

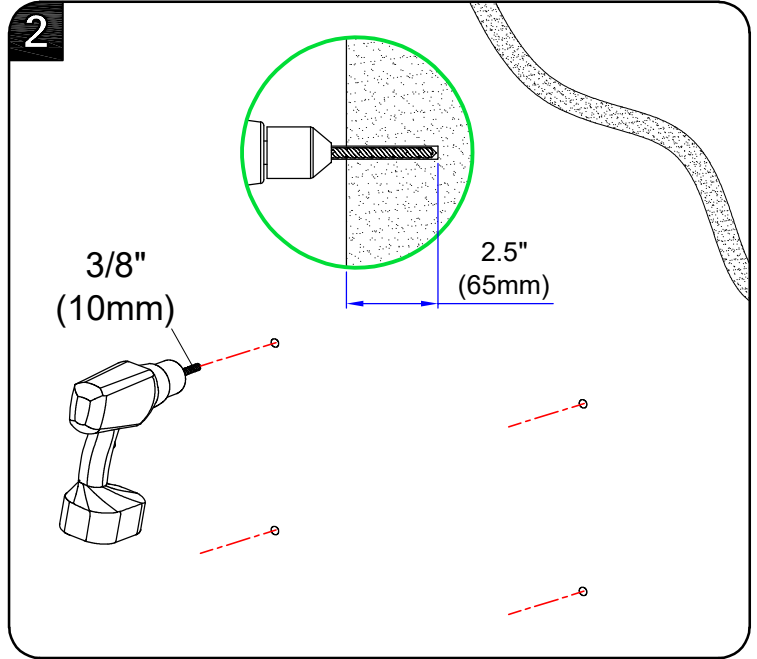
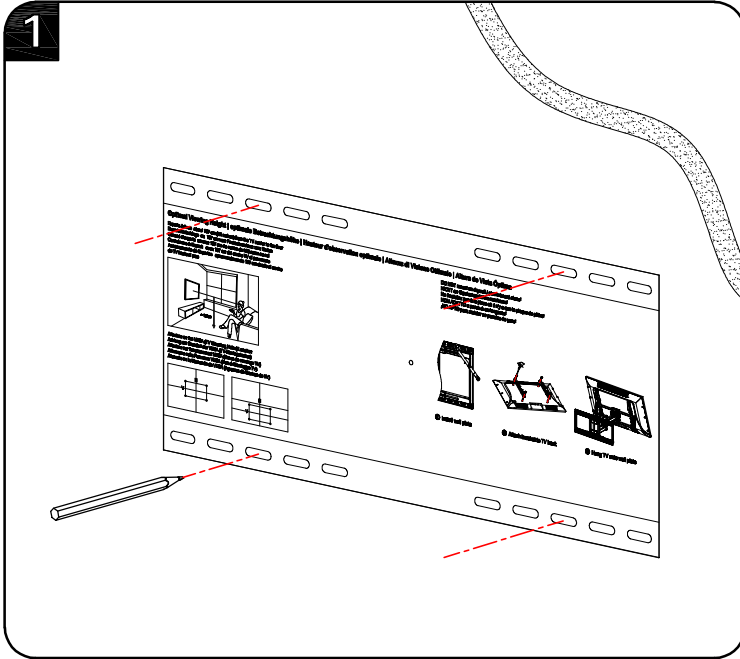
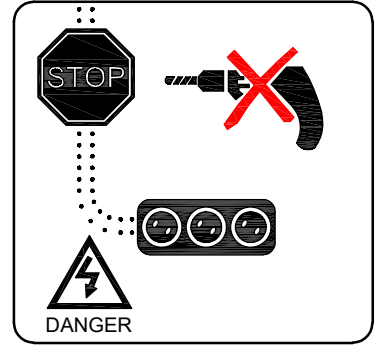
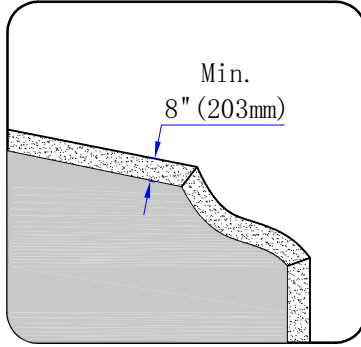

⚠ CAUTION: To avoid potential personal injury or property damage:
All 4 lag bolts **01** MUST BE firmly tightened to prevent unwanted movement of the wall plate
assembly. Ensure the wall plate assembly is securely fastened to the wall before continuing on to
the next step.
To prevent the TV falling down, the direction of the arrow should be upward as shown.

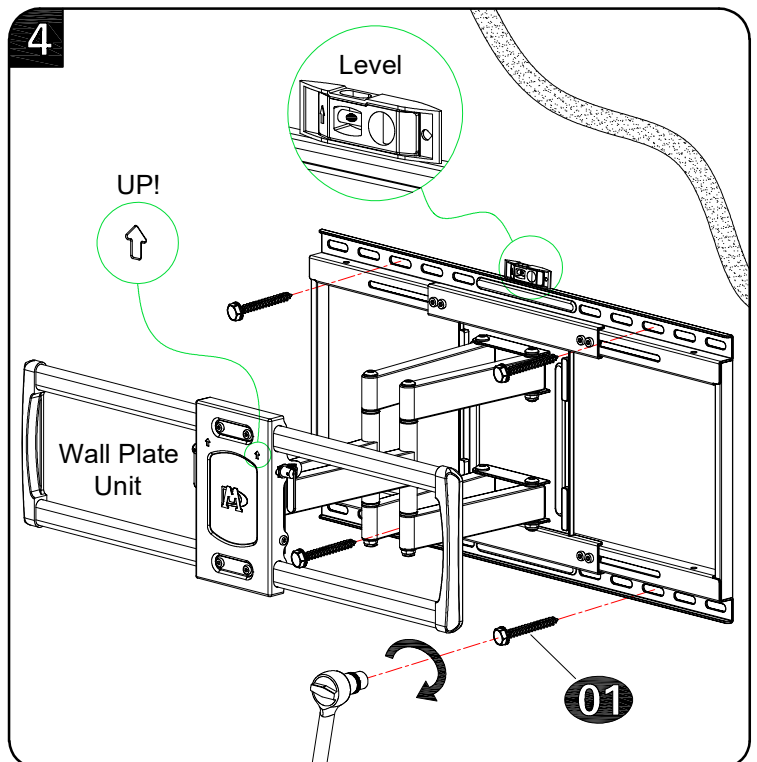
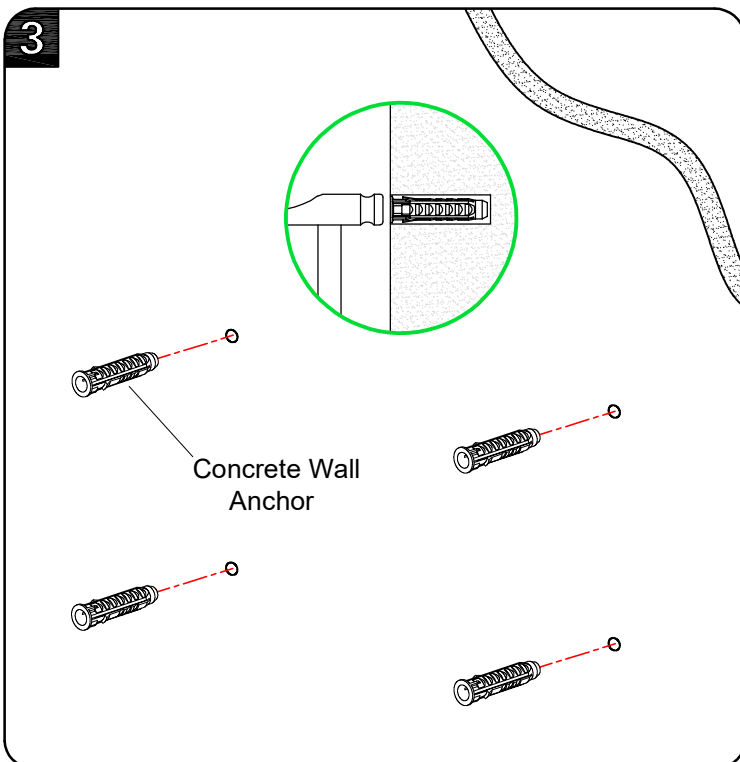

Vor der Installation bestätigen Sie bitte zuerst, ob diese Halterung für Ihr Fernsehapparat geeignet ist!

1 Ist der Abstand der Montagelöcher von Ihrem Fernsehapparat zwischen 200x100mm/8x4" und 600x400mm/24x16"?

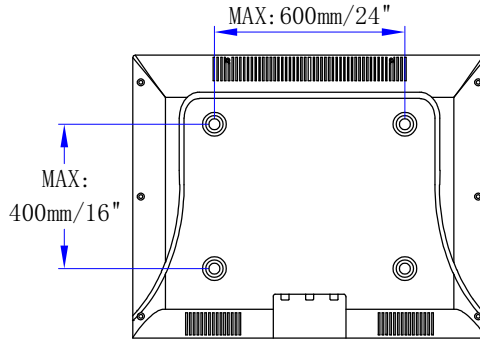

Ja - Perfekt!

Nein - Diese Halterung ist nicht geeignet!

2 Wiegt Ihr Fernsehapparat (inkl. Zubehör) weniger als 60 KG (132 LBS)?



Ja - Perfekt!

Nein - Diese Halterung ist nicht geeignet!

3 Woraus besteht Ihre Wand?

⚠ Vorsicht:
NICHT an einer reinen Gipskartonwand anbringen.

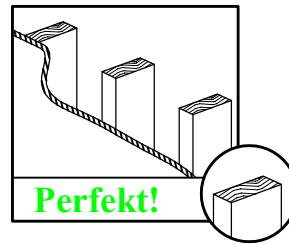

Gipskartonwand mit Holzbalken?

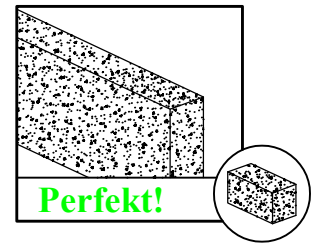

Massivbetonwand?

4 Werkzeuge für Installation (Nicht enthalten)

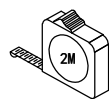

Bandmaß



Bleistift



Kreuzschlitzschraubendreher

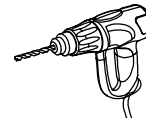

Elektrobohrer

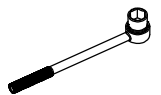

Steckschlüssel (13mm, 1/2")

Montage von Holzbalkenwand		
Balkensucher	Ahle	5,5mm (7/32") Bohreinsatz für Holz

Montage von Betonwand	
10mm (3/8") Bohreinsatz für Stein	Hammer

5 Sicherheitshinweise

Bitte lesen Sie die Anweisungen sorgfältig vor der Installation durch.

- Dieses Produkt ist für die Installation an Wänden mit Holzträgern und Massivbetonwand - NICHT an einer reinen Gipskartonwand montieren.
- Die Wand muss das Fünffache des Gesamtgewichts des Fernsehapparats und der Halterung tragen können.
- Verwenden Sie dieses Produkt nicht für einen anderen Zweck als speziell von Mounting Dream angegeben.
- Unsachgemäße Montage dieses Produkts kann zu Verletzungen und zu den Beschädigungen an Ihrem Gerät führen. Mounting Dream haftet nicht für Schäden oder Verletzungen, die durch unsachgemäße Montage, unsachgemäßen Zusammenbau oder unsachgemäße Verwendung verursacht wurden.

Installationsanweisungen

⚠️ Warnung: Dieses Produkt enthält kleine Teile, die beim Verschlucken zur Erstickungsgefahr führen können. Bevor Sie mit der Installation beginnen, überprüfen Sie bitte, ob alle Zubehörteile und Ersatzteile vollständig und unbeschädigt sind.

Hinweis: Es wird nicht das gesamte mitgelieferte Befestigungsmaterial verwendet.

Schritt 1 Befestigen Sie die Schienen am Fernseher Siehe Seite 2

Mitgelieferte Teile und Befestigungsmaterialien

1-1 Wählen Sie Schrauben für den Fernseher aus

1-2 Abstandhalter?

I Wenn nein, siehe Seite 3, Kombination **I**.

II Wenn ja, siehe Seite 3, Kombination **II**.

1-3 Befestigen Sie die Fernseher-Schienen

Tipps: Wenn Sie die Schraube M6 (e) oder M8 (c / f) mit dem 2.5mm Abstandhalter (j) kombinieren müssen, müssen Sie den inneren Ring entfernen.

Schritt 2 Befestigen Sie die Wandplatte an der Wand

Mitgelieferte Teile und Befestigungsmaterialien

Schritt 2A Die Montage von Holzbalkenwand Siehe Seite 4

⚠️ Vorsicht: Verwenden Sie keinen Dübel, wenn Sie eine Wandplatte an einer Holzbalkenwand installieren!

⚠️ Vorsicht: Alle vier Sechskant-Holzschrauben **01** müssen festgezogen werden, um ein ungewolltes Verrutschen der Wandplatte zu verhindern. Achten Sie darauf, dass die Wandplatte sicher an der Wand befestigt ist, bevor Sie mit dem nächsten Schritt anfangen.

Fahren Sie bitte nach diesem Schritt mit 3. Schritt auf der Seite 5 fort.

Damit der Fernseher nicht herunterfällt, sollte die Pfeilrichtung wie gezeigt nach oben zeigen.

Schritt 2B Die Montage von Massivbetonwand Siehe Seite 9

⚠️ Vorsicht: Alle vier Sechskant-Holzschrauben **01** müssen festgezogen werden, um ein ungewolltes Verrutschen der Wandplatte zu verhindern. Achten Sie darauf, dass die Wandplatte sicher an der Wand befestigt ist, bevor Sie mit dem nächsten Schritt anfangen.

Damit der Fernseher nicht herunterfällt, sollte die Pfeilrichtung wie gezeigt nach oben zeigen.

Schritt 3 Hängen und befestigen Sie den Fernseher an der Wandplatte Siehe Seite 5

3-1 Eine Sicherheitsprüfung für die Montage der Wandplatte

Bevor Sie den Fernseher an die Wandplatte hängen, führen Sie bitte eine Sicherheitsprüfung für die Montage der Wandplatte aus.

3-2 Hängen und befestigen Sie den Fernseher an der Wandplatte

⚠️ Vorsicht: Nachdem der Fernseher sicher an der Wandplatte aufgehängt wurde, verriegeln Sie die Sicherheitsschrauben **03** mit einem Schraubendreher, um sicherzustellen, dass keine Lockerheit auftritt.

* Aus Sicherheitsgründen wird dieser Schritt am besten von zwei Personen gemeinsam ausgeführt.

Schritt 4 Funktionseinstellung Siehe Seite 6

4-1 Nivellierungseinstellung (+/-3°)

Verwenden Sie einen Inbusschlüssel **02** und lösen Sie die zwei hinter der TV-Platte eingebettete Nivellierschrauben (Nicht mehr als zwei Umdrehungen) gegen den Uhrzeigersinn, stellen Sie die TV-Platte ein und ziehen Sie die Schrauben mit einem Schraubenschlüssel im Uhrzeigersinn fest.

4-2 Neigungseinstellung (+5°/-15°)

Griff lösen, Fernseher auf die gewünschte Position einstellen, Ziehen Sie dann den Griff fest.

4-3 Fernseher Seite zu Seite bewegen 8"

Lösen Sie vier Schrauben bei max. 2 Umdrehungen. Dabei benötigt es zwei Personen, um die Montageeinheit (Fernseher + TV-Platte + Arme) gleichzeitig anzuheben. Schieben Sie es nach links oder rechts entlang der Schiene der Wandplatte, um den Fernseher perfekt zu positionieren. Nach der Einstellung ziehen Sie die Schrauben fest.

Inbusschlüssel-Aufbewahrung:

Zur einfachen Einstellung können Sie den Inbusschlüssel wie abgebildet auf die Wandplatte stecken.

Produktabmessung Siehe Seite 8

Avant l'installation, veuillez assurer que ce support est adapté à votre téléviseur ou pas !

1 Est-ce que la distance entre des trous de montage de votre téléviseur est plus de ou égale à 200x100mm/8x4" et moins de ou égale à 600x400mm/24x16"?

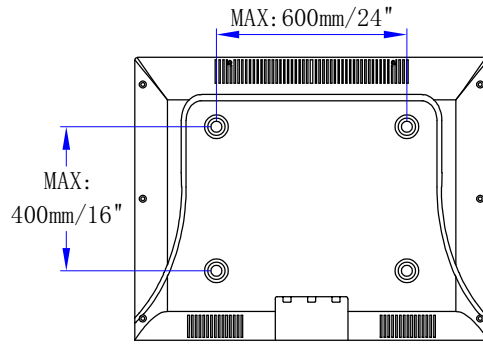

Oui - Parfait !

Non - Ce support ne vous convient pas !

2 Est-ce que votre téléviseur et des autres accessoires pèsent totalement moins de 60KG (132 LBS)?



Oui - Parfait !

Non - Ce support ne vous convient pas !

3 De quels genres matériaux le mur est fait ?

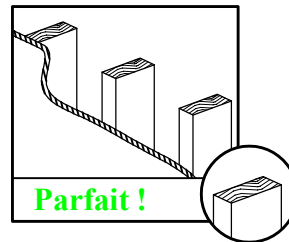
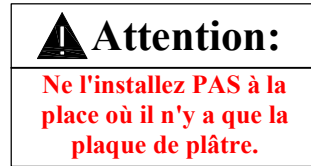

Cloison sèche avec montant en bois ?

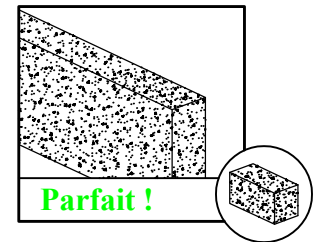

Mur en béton plein ?

4 Outils d'installation (Pas inclus)

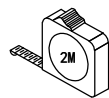

Mètres à ruban



Crayon



Tournevis Cruciforme

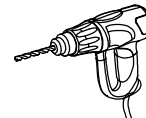

Perforateur



Clé à cliquet (13mm, 1/2")

Installation du montant en bois



Détecteur de montant en bois

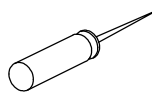

Alène



5,5mm (7/32") Foret à bois

Installation du mur en béton



10mm (3/8") Foret de maçonnerie

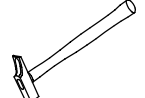

Marteau

5 Consignes de sécurité

Avant l'installation, veuillez attentivement lire ce mode d'emploi.

- Ce produit s'applique au montant en bois, au mur en béton plein - Ne l'installez pas à la place où il n'y a que la plaque de plâtre.
- La force portante du mur doit atteindre au moins cinq fois du poids total de votre téléviseur et du support.
- N'utilisez pas ce produit pour des autres objectifs non désignés par Mounting Dream.
- L'installation incorrecte causera le dommage matériel ou la blessure corporelle. Mounting Dream n'assumera aucune responsabilité pour le dommage et la blessure causés par l'installation incorrecte ou l'utilisation inadéquate.

⚠ AVERTISSEMENT : Ce produit contient des petites pièces, en cas d'ingestion, des risques de suffocation y arrivera. Avant l'installation, veuillez vérifier que tous les accessoires et toutes les pièces sont complets et non défectueux.

ATTENTION : Les pièces fournies ne seront pas toutes utilisées durant l'installation.

Étape 1 Installer des barres verticales sur votre téléviseur Voir à la page 2

Pièces et accessoires

1-1 Choisir des vis de téléviseur

1-2 Entretoises sont nécessaires ?

I Non, voir à la page 3, combinaison **I**.

II Oui, voir à la page 3, combinaison **II**.

1-3 Assembler des barres verticales

Remarque : Quand vous choisissez la vis M6(e) / M8(c / f) et l'entretoise (j) de 2,5mm est nécessaire, veuillez enlever la cercle interne.

Étape 2 Installer la plaque murale au mur

Pièces et accessoires

Étape 2A Installation du montant en bois Voir à la page 4

⚠ Attention : Quand vous installez la plaque murale au mur avec le poteau de bois, n'utilisez pas les chevilles!

⚠ Attention : Tous les quatre boulons tire-fond **01** doivent être fermement serrés pour éviter le mouvement non souhaité de la plaque murale. Veuillez vérifier que la plaque murale est fixée sur le mur avant de passer à l'étape suivante. Après avoir fini cette étape, allez directement à la page 5 et continuez l'étape 3.

Pour éviter que le téléviseur ne tombe, la direction de la flèche doit être orientée vers le haut, comme indiqué.

Étape 2B Installation du mur en béton plein Voir à la page 9

⚠ Attention : Tous les quatre boulons tire-fond **01** doivent être fermement serrés pour éviter le mouvement non souhaité de la plaque murale. Veuillez vérifier que la plaque murale est fixée sur le mur avant de passer à l'étape suivante.

Pour éviter que le téléviseur ne tombe, la direction de la flèche doit être orientée vers le haut, comme indiqué.

Étape 3 Suspendre et fixer votre téléviseur sur la plaque murale Voir à la page 5

Pièces et accessoires

3-1 Test de la fiabilité de l'installation de la plaque murale

Avant de suspendre votre téléviseur sur la plaque murale, veuillez tester la fiabilité de l'installation de la plaque murale.

3-2 Suspendre et fixer votre téléviseur sur la plaque murale

⚠ Attention : Après avoir suspendu votre téléviseur sur la plaque murale, veuillez bien serrer les vis de sécurité **03** au tournevis cruciforme pour assurer qu'elles sont fixes.

* Compte tenu de la sécurité, deux personnes sont nécessaires pour l'installation.

Étape 4 Ajustement de fonction Voir à la page 6

4-1 L'ajustement du niveau (+/-3°)

Desserrer à la clé hexagonale **02** les deux vis de niveau à l'arrière de la plaque TV (pas plus de deux tours), ajuster le niveau et puis serrer les vis.

4-2 L'ajustement de l'angle d'inclinaison (+5°/-15°)

Desserrez la poignée, ajustez le téléviseur à la position souhaitée, puis serrez la poignée.

4-3 Mouvement latéral de TV 8"

Desserrez les quatre boulons de deux tours maximum, deux personnes sont requises pour soulever l'unité de montage (TV + plaque TV + bras) et en même temps la glisser à gauche ou à droite le long du rail de la plaque murale pour positionner parfaitement le téléviseur. Ensuite serrer les boulons après le réglage.

Pour un réglage facile, vous pouvez placer la clé Allen sur la plaque murale comme illustration.

Dimensions de produit Voir à la page 8

Antes de comenzar a instalar este soporte mural para tv , favor confirme si es el adecuado para su televisor!

1 Los orificios posteriores de su televisor tienen una distancia mayor o igual a 200x100mm/8x4" y menor o igual a 600x400mm/24x16"?

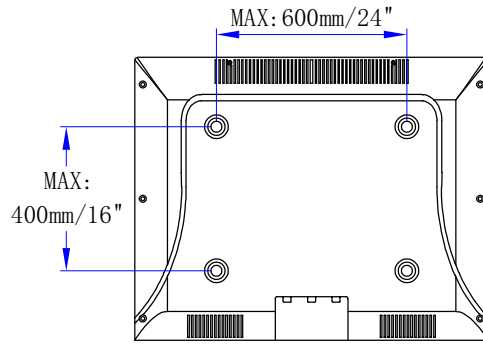

Si - Es el adecuado!

No - Este soporte no es el adecuado!

2 El peso de su televisor y los demás accesorios en total es menor a 60 KG (132 LBS)?



Si - Es el adecuado!

No - Este soporte no es el adecuado!

3 La pared de que material esta construida?

⚠ Atención:
En paredes de yeso o derivados no se debe instalar.

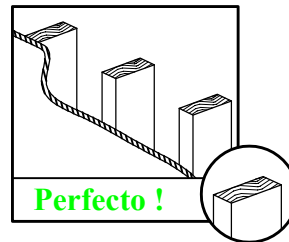

Instalar en paredes con pilares de madera?

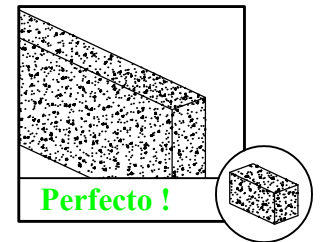

Instalar en paredes de hormigón sólido ?

4 Herramientas necesarias para su instalación (No incluido)

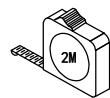

Cinta Métrica



Lápiz



Destornillador de Cruz

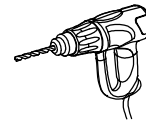

Taladro Eléctrico

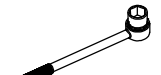

Juego de llaves (13mm, 1/2")

Instalación en pared con pilares de madera



Detector de Madera

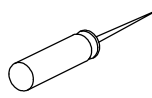

Punzón



5,5mm (7/32") Broca para Madera

Instalación en pared de hormigón



10mm (3/8") Broca de Impacto

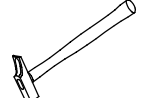

Martillo

5 Advertencias de seguridad

Antes de la instalación favor de leer en detalle el manual de instrucciones.

- Este producto es apto para paredes con pilares de madera, y muro de hormigón sólido - No instalar en paredes de solo yeso.
- La capacidad de soporte de la pared debe ser cinco veces más que el peso total del televisor y el soporte.
- Favor NO utilizar el producto de Mounting Dream para otros usos no asignados.
- La instalación incorrecta puede producir daños al producto o lesiones al usuario. Cualquier pérdida o daño debido por la mala instalación o uso indebido, Mounting Dream no asume ninguna responsabilidad.

Instrucciones paso a paso de su instalación

⚠ Advertencia: Este producto contiene piezas pequeñas, si por error se ingiere, puede provocar peligro de asfixia. Antes de comenzar la instalación, favor compruebe que todos los accesorios y piezas de repuesto estén completas y sin daño alguno.

Atención: No todas las piezas se utilizarán.

Paso 1 Instalar las varillas del soportes al televisor Ver página 2

Accesorios y piezas

1-1 Elegir los tornillos para el televisor

1-2 Necesito espaciadores?

I No necesito, favor ver la combinación **I** en la página 3.

II Necesito, favor ver la combinación **II** en la página 3.

1-3 Instalar las varillas del soporte

Tips: Si necesita espaciadores de 2,5mm (j) combinados con tornillos de M6(e) / M8(c / f), favor retirar la argolla/anillo.

Paso 2 Instalar la placa mural

Accesorios y piezas

Paso 2A Instalación en pared con pilares de madera Ver página 4

⚠ Atención: Al momento de instalar el panel en la pared con pilares de madera, favor no usar los tacos/tarugos para la pared de hormigón!

⚠ Atención: Los cuatro tornillos **01** de cabeza hexagonal deben apretarse firmemente, para evitar que la placa mural en la pared se mueva. Favor de asegurarse que quede firmemente estable en la pared para poder continuar con los siguientes pasos de la instalación. Luego de terminar este paso favor continuar con el paso 3 en la página 5.

Para evitar que el televisor se caerse, la dirección de la flecha debe ser hacia arriba como se muestra.

Paso 2B Instalación en pared de hormigón sólido Ver página 9

⚠ Atención: Los cuatro tornillos **01** de cabeza hexagonal deben apretarse firmemente, para evitar que la placa mural en la pared se mueva. Favor de asegurarse que quede firmemente estable en la pared para poder continuar con los siguientes pasos de su instalación.

Para evitar que el televisor se caerse, la dirección de la flecha debe ser hacia arriba como se muestra.

Paso 3 Colgar y sujetar del televisor a la placa mural Ver página 5

Accesorios y piezas

3-1 Prueba de confiabilidad a la instalación de la placa mural

Antes de colgar el televisor en la placa mural, favor realizar una prueba de confiabilidad a la instalación.

3-2 La colocación y sujeción del televisor a la placa mural

⚠ Atención: Después de colgar el televisor en el soporte mural, favor use el destornillador para apretar los tornillos **03** de seguridad, asegurando que no haya ningún afloje.

* Por razones de seguridad, para concluir este paso es mejor hacerlo en compañía de otra persona.

Paso 4 Funciones de regulación Ver página 6

4-1 Regulación de nivel (+/-3°)

Use una llave hexagonal **02** y afloje (máximo 2 vueltas) los 2 tornillos de nivelación que están detrás de la placa del televisor, regule el nivel, y luego vuelva a apretar los tornillos.

4-2 Regulación del ángulo de inclinación (+5°/-15°)

Afloje la manija, ajuste el televisor a la posición deseada, luego apriete la manija.

4-3 Movimiento de lado a lado de televisor 8"

Afloje los cuatro pernos por un máximo de 2 vueltas y se requiere 2 personas para cooperar a levantar la unidad de montaje (TV + panel de soporte de TV + brazos) al mismo tiempo deslícela hacia la izquierda o hacia la derecha a lo largo del riel del panel de soporte de pared para colocar perfectamente e televisor. Luego apriete los pernos después del ajuste.

Para facilitar el ajuste, puede colocar la llave Allen en la placa de pared como se muestra en la ilustración.

Dimensiones del producto Ver página 8

Prima di iniziare l'installazione, per prima cosa conferma se questo Supporto è ideale per la vostra TV!

1 La distanza dei fori di installazione TV sono superiore/uguale a 200x100mm/8x4" e inferiore /uguale a 600x400mm/24x16"?

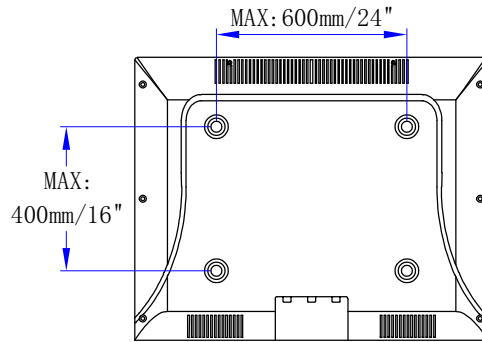

Sì - Ideale!

No - Questo supporto non va!

2 Il tuo televisore (inclusi accessori) pesa totalmente inferiore a 60 KG (132 LBS)?



Sì - Ideale!

No - Questo supporto non va!

3 Di che materiale è fatto il muro?

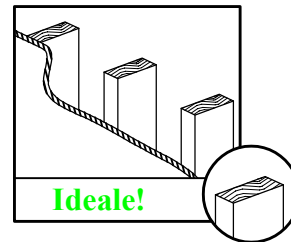

Muro secco con i pilastri in legno?

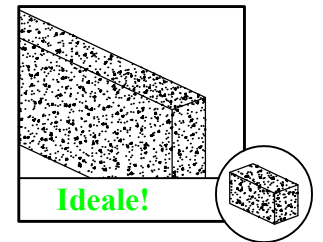

Muro in calcestruzzo solido ?

4 Utensili per installazione (Non incluso)

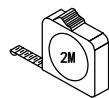

Metro a nastro



Matita



Cacciavite a croce

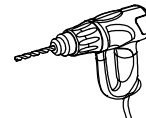

Trapano elettrico



Chiave a tubo 13mm (1/2")



Rivelatore di pilastro in legno

Punteruolo

5,5mm (7/32")
Punta da trapano per legno



10mm (3/8")
Punta da trapano a percussione

Martello

5 Cautele per sicurezza

Leggi attentamente le istruzioni prima di installazione.

- Questo prodotto è progettato per pilastri in legno e muri in calcestruzzo solido - NON installarlo in soli cartongessi.
- Il muro deve essere capace di portare almeno cinque volte il peso totale del televisore e del supporto.
- Non applicare questo prodotto ad altri scopi non indicati da Mounting Dream.
- L'installazione errata potrebbe causare danni al prodotto o lesioni personali. Mounting Dream non si assume alcuna responsabilità per danni o lesioni causate da installazione impropria o uso improprio.



Istruzioni di installazione

⚠ Avvertenza: Questo prodotto contiene piccoli articoli che potrebbe causare il pericolo di soffocamento se ingoiati. Prima di iniziare l'installazione, controlla se tutti gli accessori e parti siano inclusi e non danneggiati.

Nota: Non verranno utilizzati tutte le parti incluse.

Passo 1 Installa barre verticali al televisore Vedi pagina 2

Accessori e parti

1-1 Seleziona viti TV

1-2 Si ha bisogno di pilastri con guarnizione?

I No, vedi la combinazione **I** nella pagina 3.

II Sì, vedi la combinazione **II** nella pagina 3.

1-3 Installazione di barre verticali

Suggerimento: se è necessario combinare il pilastro con guarnizione 2,5mm (j) con la vite M6(e) / M8(c / f), rimuovi l'anello interno.

Passo 2 Installa la piastra a muro sul muro

Accessori e parti

Passo 2A Installazione sul muro con i pilastri in legno Vedi pagina 4

⚠ Cautela: Quando si installa la piastra a muro sul muro con pilastri in legno, non utilizzare i tasselli per il muro in calcestruzzo!

⚠ Cautela: Le quattro viti **01** per Legno a testa esagonale devono essere avvitate bene in modo da evitare movimenti indesiderati della piastra a muro. Assicura che la piastra a muro sia ben fissata sul muro prima di eseguire il prossimo passo. Dopo finire questo passo, va direttamente alla pagina 5 per il passo 3.

Per evitare che la TV cada, la direzione della freccia dovrebbe essere verso l'alto come mostrato.

Passo 2B Installazione sul muro in calcestruzzo Vedi pagina 9

⚠ Cautela: Le quattro viti **01** per Legno a testa esagonale devono essere avvitate bene in modo da evitare movimenti indesiderati della piastra a muro. Assicura che la piastra a muro sia ben fissata sul muro prima di eseguire il prossimo passo.

Per evitare che la TV cada, la direzione della freccia dovrebbe essere verso l'alto come mostrato.

Passo 3 Appendi e fissa la TV alla piastra a muro Vedi pagina 5

3-1 Test di affidabilità dell'installazione della piastra a muro

Prima di appendere la TV alla piastra a muro, esegui un test di affidabilità dell'installazione della piastra a muro.

3-2 Appendi e fissa la TV alla piastra a muro

⚠ Cautela: Dopo appendere la TV alla piastra a muro, avvita bene le viti **03** di sicurezza con un cacciavite assicurando che non si allenti.

* Per la sicurezza, è meglio eseguire questo passo da due persone.

Passo 4 Regolazioni di funzione Vedi pagina 6

4-1 Regolazione di livello (+/-3°)

Allenta (due cerchi al massimo) con la chiave a brugola interna **02** le due viti di livellamento sul retro della piastra TV, le regola al livello e le avvita nuovamente per fissarle.

4-2 Regolazione dell'angolo di inclinazione (+5°/-15°)

Allentare la maniglia, regolare la TV nella posizione desiderata, quindi stringere la maniglia.

4-3 Movimento TV da un lato all'altro 8"

Allentare quattro bulloni di massimo 2 giri e serve la cooperazione di due persone per sollevare l'unità di assemblaggio (TV + TV piastra + bracci) allo stesso tempo farlo scorrere a sinistra o a destra lungo la guida della piastra a muro per posizionare perfettamente la TV. Poi bloccare i bulloni dopo la regolazione.

Per una facile regolazione, è possibile posizionare la chiave a brugola sulla piastra a parete come da illustrazione.

Dimensioni del prodotto Vedi pagina 8