

SNOWBOARD RACK

KOOVA[®]

SNOWBOARD RACK INSTALLATION INSTRUCTIONS v1.0



1x Koova Strut

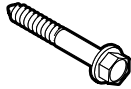

2x 1/4 x 2 3/4 Lag Bolt



2x Flat Washer

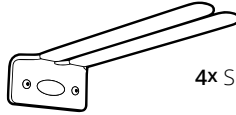

4x Snowboard Hangers

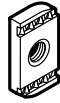

8x Koova Nuts



8x 1/4-20 x 1 Black Bolts

TOOLS NEEDED

- Socket wrench with 5/16" socket
- Phillips head screwdriver
- Stud finder (recommended)
- Pencil for marking mount location

If the mounting wall requires masonry hardware, email us at support@koova.com and we will get some sent to you!

INSTALLATION WARNING

To safely support the weight of your snowboard, ensure that the Koova Lag Bolts are installed into studs. Failure to mount the Koova System in studs may result in damage to property and/or personal injury.

All necessary precautions should be taken when using a drill to ensure that no electrical wires are located where you are drilling. Failing to ensure that no wiring exists at the point of drilling can lead to serious bodily injury and property damage.

STEP ONE: MOUNT THE KOOVA STRUT

- Locate the wood studs and mark their locations along the same horizontal line as the marks made in the previous step (*figure b*). Studs are usually 16" apart.
- Hold your longest snowboard against the wall and place a mark just below the top binding (*figure a*).

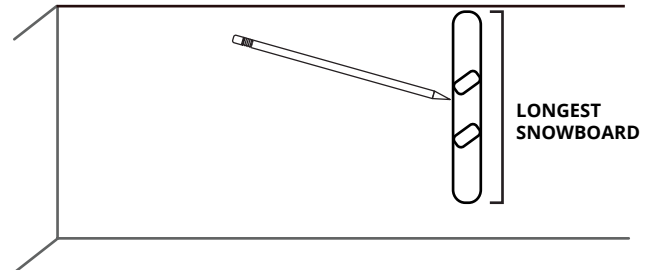

figure a

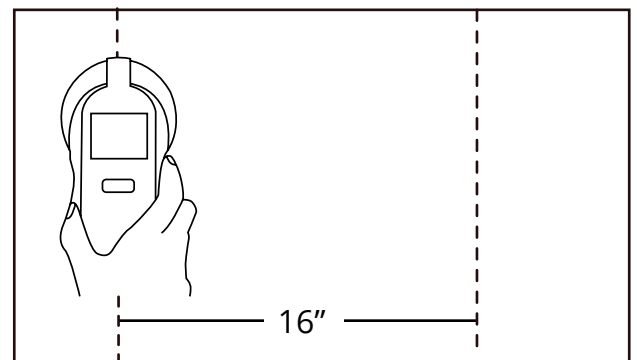

figure b

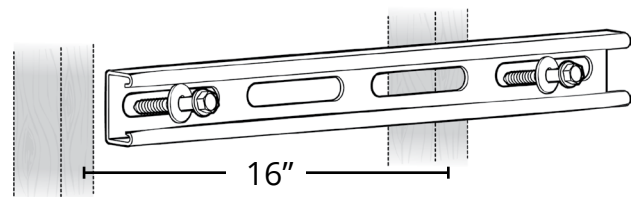

figure c

NO STUD FINDER?

If you do not have a stud finder, please review the information located at <https://koova.com/pages/product-support> for safe alternatives to using a stud finder.

- Using the socket wrench (or electric drill driver), loosely screw one Koova lag bolt with washer into the marked location on the stud. Do not tighten.
- Use a level to make sure the strut is straight and install the second lag bolt into the next closest stud.

NEED A LEVEL?

Your smartphone may have a level app already installed. If not there are many free apps available for most smartphones.

KOOVA

NEED ASSISTANCE?
Contact us at support@koova.com or at koova.com

© 2021 Alphidia, LLC. © 2019 Alphidia, LLC.

STEP TWO: MOUNT THE ATTACHMENTS

- Insert the Koova bolts into front of the snowboard hanger attachment and loosely screw the Koova nut onto the bolt. Make sure the side with the textured part of the Koova nut is facing the back of the hook as shown (figure d).
- Place the attachment on the Koova strut with the nut turned so that it will fit easily into the strut.
- Using your phillips screwdriver, turn the Koova bolt clockwise. Make sure the Koova nut turns 90 degrees inside the strut (it should do this automatically but check to make sure). Continue tightening the bolt until secure.
- Repeat with each additional snowboard hanger (figure e).

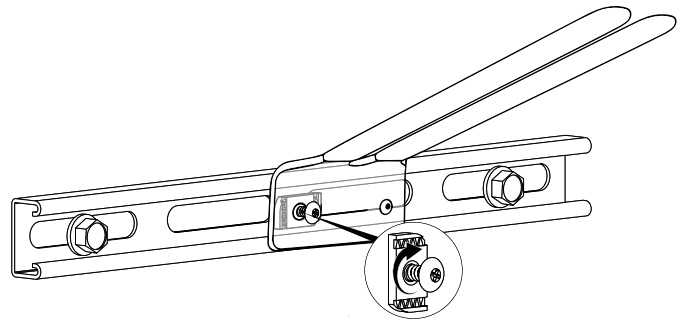

figure d

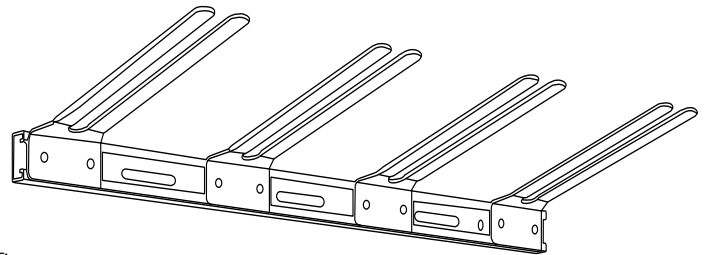

figure e

STEP THREE: INSERT YOUR BOARD

- Space your snowboard hangers evenly on the strut. You may need to slide the attachments to the left or right.
- Slide the snowboard between the bindings into the hanger. The snowboard bindings will rest on the top of the protective rubber sleeves (figures f and g).

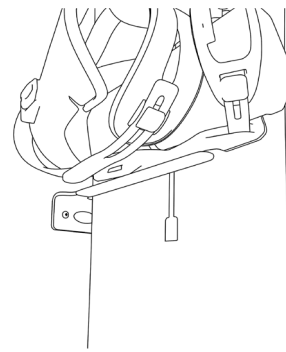

figure f

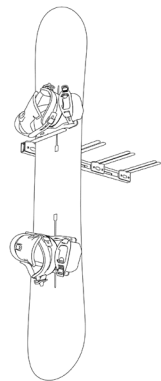

figure g

KOOVA HELPS YOU PUT EVERYTHING IN ITS PLACE!



GOLF BAG ORGANIZATION



GARDEN & GARAGE ORGANIZATION



TOOL ORGANIZATION



SKATEBOARD ORGANIZATION



HOME ORGANIZATION



HOME OFFICE ORGANIZATION

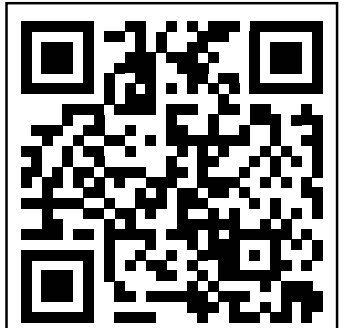

SHOP **KOOVA.COM**
FOR OTHER GREAT
ORGANIZATIONAL
SOLUTIONS