

**SHOP STOOL  
ULTRA CUSHIONED**





**TABOURET D'ATELIER  
ULTRA COUSSINÉ**

**TABURETE PARA TALLER  
ULTRA ACOJINADO**

ITM. / ART. 1433893  
Model / Modèle / Modelo : AC532518

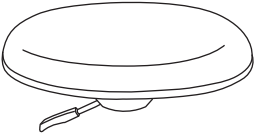
CARE & USE INSTRUCTIONS: IMPORTANT, RETAIN FOR FUTURE REFERENCE: READ CAREFULLY  
DIRECTIVES D'UTILISATION ET D'ENTRETIEN: IMPORTANT, CONSERVER POUR RÉFÉRENCE FUTURE: LIRE ATTENTIVEMENT  
INSTRUCCIONES DE CUIDADO Y USO: IMPORTANTE, CONSERVE PARA FUTURA REFERENCIA: LEA CUIDADOSAMENTE

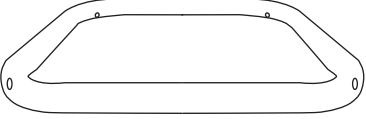
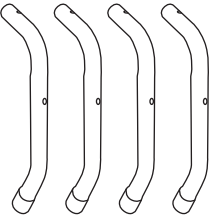
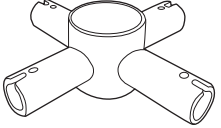
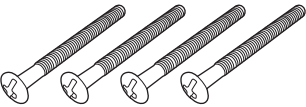
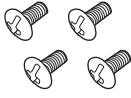
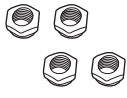
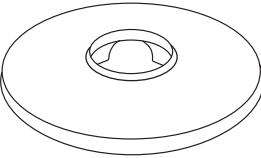
PACKAGE CONTAINS / L'EMBALLAGE CONTIENT / CONTENIDO DEL PAQUETE

- |   |  |  |  |  |
|---|--|--|--|--|
| A. Seat<br>A. Siège<br>A. Asiento   | B. Cylinder<br>B. Cylindre<br>B. Cilindro  | C1. Base Frame<br>C1. Base<br>C1. Armazón base                                     | C2. Base Leg x 4<br>C2.4 pieds de base<br>C2. Pata de la base x 4                    | C3. Base Cross Coupler<br>C3. Base en croix<br>C3. Acoplador en cruz de la base      |
|      |   |   |    |   |
| C4. Coupler screw x 4<br>C4. 4 vis à tête ronde<br>C4. Tornillo para el acoplador x 4 | C5. Frame screw x 4<br>C5. 4 vis pour la base<br>C5. Tornillo para armazón x 4     | C6. Screw Nut x 4<br>C6. 4 écrous<br>C6. Tuerca x 4                                | D. Footrest<br>D. Repose-pieds<br>D. Apoyapies                                       | E. Spanner<br>E. Clef<br>E. Llave  |
|      |  |  |  |  |

Not provided: Screwdriver / Non fourni: Tournevis / No incluido: Destornillador

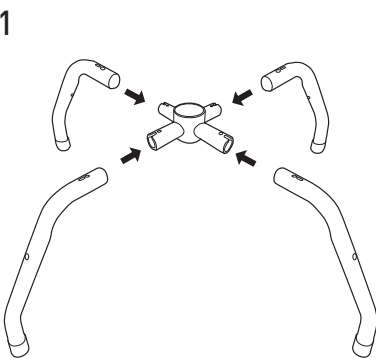
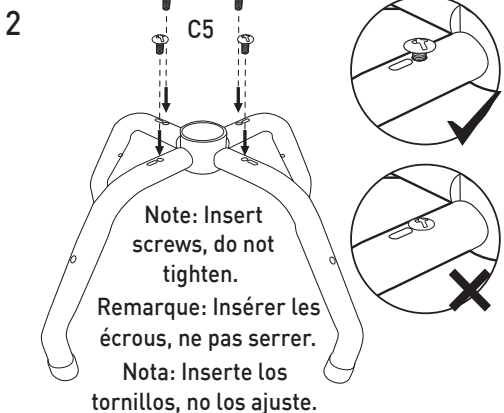

INSTALLATION / INSTALLATION / INSTALACIÓN

- 
- 

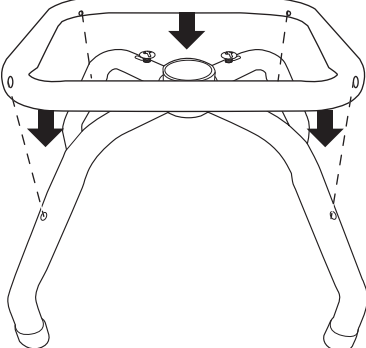
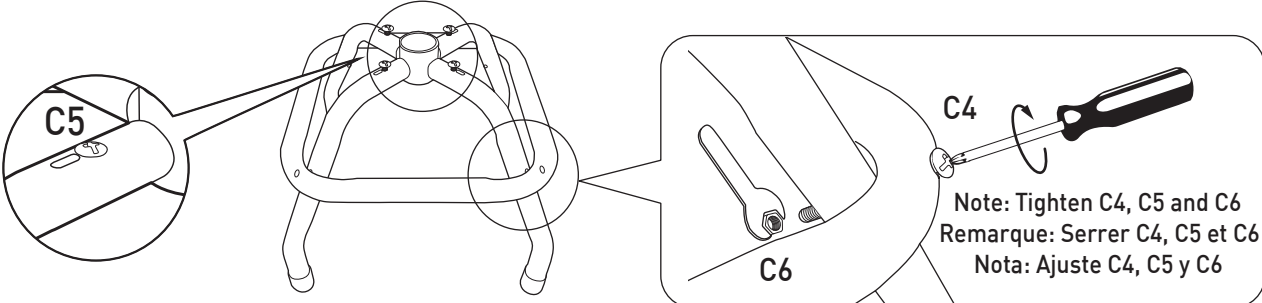
Note: Insert screws, do not tighten.  
Remarque: Insérer les écrous, ne pas serrer.  
Nota: Inserte los tornillos, no los ajuste.
- 
- 

Note: Tighten C4, C5 and C6  
Remarque: Serrer C4, C5 et C6  
Nota: Ajuste C4, C5 y C6

# INSTALLATION / INSTALLATION / INSTALACIÓN

5

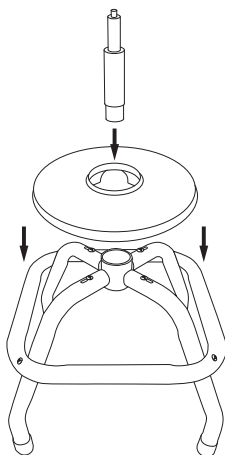

6

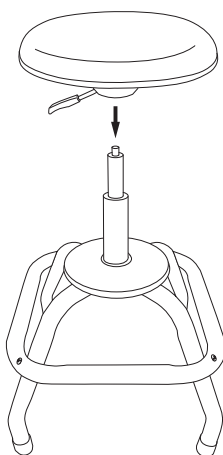

7

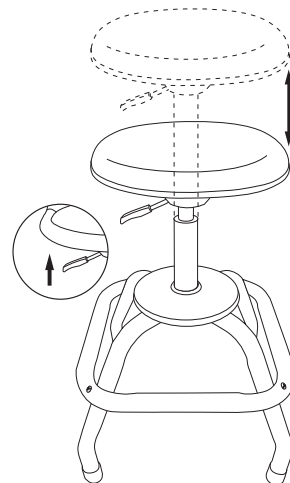

## STOOL DIMENSIONS / DIMENSIONS DU TABOURET / DIMENSIONES DEL TABURETE

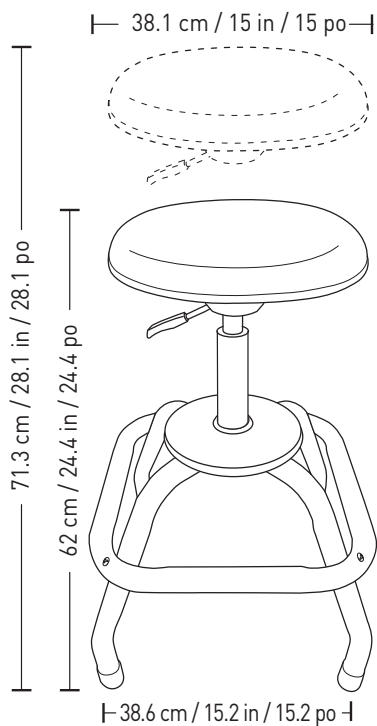

Approximately / Approximativement / Aproximadamente

## WARNING

### FAILURE TO HEED THESE WARNINGS CAN LEAD TO SERIOUS INJURY

1. **DO NOT** overload – the maximum weight capacity is 250 lb / 113 kg
2. **DO NOT** stand on stool or use the stool as a ladder
3. **DO NOT** tilt or lean back on the stool
4. **DO NOT** sit on the edge of the stool
5. **DO NOT** use the stool on uneven or nonlevel surface
6. For indoor use only
7. Only use the stool when fully and properly assembled
8. If the stool is not operating properly or if any parts are loose, broken or missing, immediately stop using the stool and contact our customer service.

## AVERTISSEMENT

### LE NON-RESPECT DE CES AVERTISSEMENTS PEUT ENTRAÎNER DES BLESSURES GRAVES

1. **NE PAS** surcharger: la capacité maximale relative au poids est de 113 kg/250 lb
2. **NE PAS** se tenir debout sur un tabouret ou utiliser le tabouret comme une échelle
3. **NE PAS** s'incliner ou se pencher vers l'arrière sur le tabouret
4. **NE PAS** s'asseoir sur le rebord du tabouret
5. **NE PAS** utiliser le tabouret sur une surface inégale ou non plane
6. Destiné uniquement à une utilisation à l'intérieur
7. N'utilisez le tabouret que lorsqu'il est entièrement et correctement assemblé
8. Si le tabouret ne fonctionne pas correctement ou si des pièces sont desserrées, cassées ou manquantes, cessez immédiatement d'utiliser le tabouret et communiquez avec notre service à la clientèle.

## ADVERTENCIA

### NO PRESTAR ATENCIÓN A ESTAS ADVERTENCIAS PUEDE RESULTAR EN LESIONES GRAVES

1. **NO** sobrecargar. La máxima capacidad de peso es 113 kg/250 libras.
2. **NO** se suba sobre el taburete ni lo utilice como escalera.
3. **NO** incline el taburete ni se incline hacia atrás sobre el taburete.
4. **NO** se sienta en el borde del taburete.
5. **NO** use el taburete en superficies irregulares o desniveladas.
6. Solo para uso en interiores.
7. Solo use el taburete cuando esté ensamblado totalmente y de modo correcto.
8. Si el taburete no está funcionando adecuadamente o si alguna pieza está floja, rota o falta, deje de usar el taburete de inmediato y póngase en contacto con nuestro servicio a clientes. (Servicio no válido en México).

## CLEANING INSTRUCTION

1. Wipe clean with a damp cloth

## INSTRUCTIONS DE NETTOYAGE

1. Nettoyer à l'aide d'un chiffon humide

## INSTRUCCIONES DE LIMPIEZA

1. Límpiela con una tela

**KODA**™ / MC / MR

A Horizon Brands Company  
2975 Red Hill Ave., Ste. 100,  
Costa Mesa, CA 92626 USA  
M-F / L-V, 8AM - 5PM (Pacific Time)  
Tel: 1-866-294-9244 (English only)  
info@kodabuilt.com

©2021 Koda.  
All rights reserved.  
Tout droit réservé.  
Todos los derechos reservados.

MADE IN CHINA  
FABRIQUÉ EN CHINE  
HECHO EN CHINA

Distributed by:  
Costco Wholesale Corporation  
P.O. Box 34535  
Seattle, WA 98124-1535  
USA  
1-800-774-2678  
www.costco.com

Costco Wholesale UK Ltd /  
Costco Online UK Ltd  
Hartspring Lane  
Wattford, Herts  
WD25 8JS  
United Kingdom  
01923 213113  
www.costco.co.uk

Costco Wholesale Japan Ltd.  
3-1-4 Ikegami-Shincho  
Kawasaki-ku, Kawasaki-shi,  
Kanagawa 210-0832 Japan  
0570-032600  
www.costco.co.jp

Costco Wholesale Canada Ltd.\*  
415 W. Hunt Club Road  
Ottawa, Ontario  
K2E 1C5, Canada  
1-800-463-3783  
www.costco.ca  
\* faisant affaire au Québec sous  
le nom les Entrepôts Costco

Costco Wholesale Spain S.L.U.  
Poligono Empresarial Los Gavilanes  
C/ Agustín de Betancourt, 17  
28906 Getafe (Madrid) España  
NIF: B86509460  
900 111 155  
www.costco.es

Costco Wholesale Korea, Ltd.  
40, Iljik-ro  
Gwangmyeong-si  
Gyeonggi-do, 14347, Korea  
1899-9900  
www.costco.co.kr

Importado por:  
Importadora Primex S.A. de C.V.  
Blvd. Magnocentro No. 4  
San Fernando La Herradura  
Huixquilucan, Estado de México  
C.P. 52765  
RFC: IPR-930907-S70  
(55)-5246-5500  
www.costco.com.mx

Costco Wholesale Iceland ehf.  
Kauptún 3-7, 210 Gardabaer  
Iceland  
www.costco.is

Costco Wholesale New Zealand Limited  
67 Maki Street  
Massey, Auckland 0814  
New Zealand

Costco Wholesale Australia Pty Ltd  
17-21 Parramatta Road  
Lidcombe NSW 2141  
Australia  
www.costco.com.au

Costco France  
1 avenue de Bréhat  
91140 Villebon-sur-Yvette  
France  
01 80 45 01 10  
www.costco.fr

Shanghai Minhang Costco Trading Co., Ltd  
No. 235, ZhuJian Road  
Minhang District, Shanghai  
China 201106  
+86-21-6257-7065