

KODA™

LED POWER FAILURE NIGHT LIGHT (3-pack)

ITM. / ART. 2323014
Model / Model / Model: LM030164

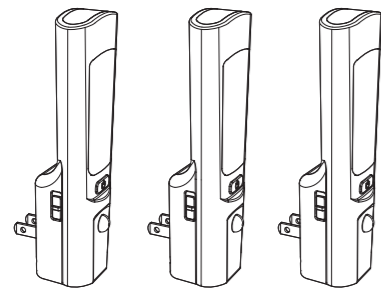

IMPORTANT INFORMATION. PLEASE READ CAREFULLY AND RETAIN FOR FUTURE REFERENCE

For assistance with assembly, installation, parts or customer service, please contact us:

info@kodabuilt.com

1-866-294-9244, Monday to Friday, 8am to 5pm Pacific Time

2975 Red Hill Ave., Suite 100, Costa Mesa, CA 92626, USA

IMPORTANT SAFETY INSTRUCTIONS

DANGER - To reduce the risk of electric shock: Always unplug this product from the electrical outlet before cleaning.

WARNING: To reduce the risk of fire, electric shock, or injury to persons:

- Disconnect the product from the power supply before servicing, when cleaning, and similar actions.
- Do not insert any foreign objects into this product.
- Store the product indoors when not in use.
- Do not clean this product with a water spray or the like. Always refer to the cleaning instruction prior to cleaning.
- For indoor and dry location use only.
- For input voltage, input power, input current and applicable light source, please refer to the label.
- Make sure that the light is completely plugged into the socket.
- Do not expose this product to rain or moisture. Do not place object filled with liquids or or near this unit.
- Do not expose this product to high temperatures, keep away from open flame.
- Do not place objects filled with chemicals on or near this unit. Do not place unit in area which is high in dust or dirt.
- Inspect the product before using for any visual damage or defects. Do not use if the product has been damage.
- Do not modify or change the materials and parts by yourself.
- Use the product with care and avoid dropping or any sudden impacts which may result in undesirable operation.
- Avoid injury due to fall off, install securely.

CAUTION: Risk of Electric Shock and Fire Hazard.

- This is not a toy and is not intended for use by children.
- For use by adults or with adult supervision.
- To prevent electric shock, match the wide blade of the plug to the wide slot of the wall outlet, then fully insert the plug into the outlet.
- Do not use with extension cords.

WARNING - When using the flashlight feature, additional precautions should be followed, including the following:

- To reduce the risk of injury and injuries to others, use the product as intended, any other use of the product may result in undesirable performance.
- Do not touch or hold the flashlight by the lens or the top of the flashlight. To reduce the risk of injury, only handle the flashlight by the base.
- Only use the attachments recommended or sold by KODA.
- To prevent fire or shock hazard, do not expose this unit to rain or moisture. Do not place objects filled with liquids on or near this unit.
- To reduce the risk of electrical shock, do not use near or in water.
- **WARNING:** To reduce the risk of injury, do not stare directly into the flashlight when it is on. Serious eye injury could occur.
- Do not operate any product with a damaged plug, or after the product malfunctions, or is dropped or damaged in any manner. Return product to the nearest authorized service facility for examination, repair, or electrical or mechanical adjustment.
- Keep out of reach of children.

MAINTENANCE:

- Regular and consistent use of the device helps in preparing a long battery lifespan.
- Fully charge the battery then unplug and store the light when not in use for an extended period of time

CLEANING INSTRUCTIONS:

When cleaning, make sure you have unplugged the light and allow it to cool to room temperature. Do not open the retaining clips when cleaning. The light can be cleaned with a feather duster or a soft damp cloth. You should only plug in the light after it has been completely dried.

PACKAGE CONTAINS:

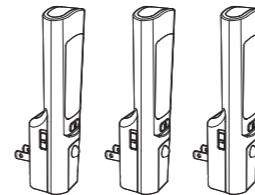

3 x LED Power Failure Night Light

OPERATION INSTRUCTIONS :

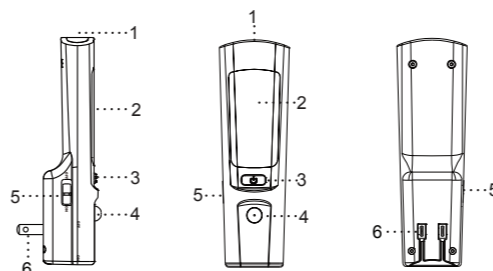

1. Flashlight
2. Nightlight
3. On/Off
4. PIR Sensor
5. Motion Sensor Switch
6. Folded Plug

1. Handheld Flashlight (unplug)

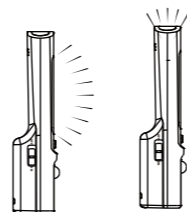

© 1x



2x

Nightlight
Press the On/Off button once to turn on the nightlight.

Flashlight
Press the operation button twice to turn on the flashlight. Press the operation button once more to turn off the light.

NOTE: Each time you remove the light from the wall outlet, the nightlight will automatically illuminate to be used as a handheld light.

2. Automated Lighting (plug to socket)

Motion Sensor On

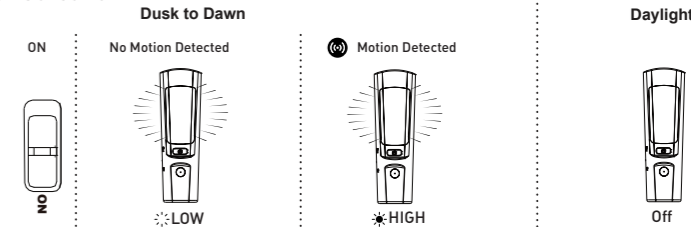

Turn the Motion Sensor switch to "ON". The nightlight will remain on at low brightness while the surrounding is dark. When motion is detected, the nightlight will change to full brightness. The nightlight will return to low brightness when no motion is detected around 30 seconds. The light will turn off automatically when the sensor detects light from the surrounding area.

Motion Sensor Off

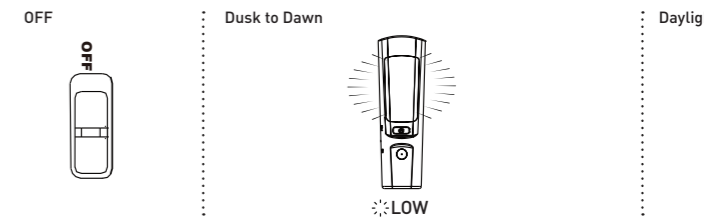

The nightlight will automatically turn on when the sensor no longer detects sufficient light. The light will then automatically shut off in daylight.

3. Power Outage Activation

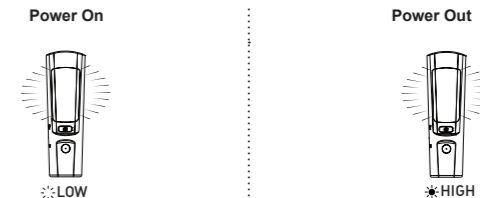

Should a power outage occur while the light is docked on the wall outlet, the nightlight will automatically activate in High Lumen for safe visibility, regardless of whether or not dimmer mode is activated and day or night.

PRODUCT SPECIFICATIONS:

1. Operating Voltage: 110 Vac, 60 Hz
2. Wattage: 0.49 W
3. Light Output: 30 lm (Flashlight), 30 lm (Nightlight)
4. Rechargeable Battery Capacity: 250 mAh



Intertek

This product is ETL/cETL Listed

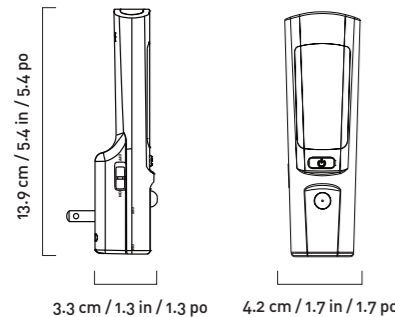

Warranty:

This Koda product carries a 5-year warranty against defects in workmanship and materials subject to the conditions and additional warranty information available at: www.kodabuilt.com/warranty

DISCLAIMER OF WARRANTIES, INCLUDING WARRANTY OF MERCHANTABILITY AND WARRANTY OF FITNESS FOR PARTICULAR PURPOSE: EXCEPT AS SPECIFICALLY SET FORTH HEREIN, NO WARRANTY OR REPRESENTATION, EXPRESS OR IMPLIED, IS MADE AS TO THE LED POWER FAILURE NIGHT LIGHT. KODA AND/OR ITS AFFILIATES EXPRESSLY DISCLAIMS, WITHOUT LIMITATION, ANY STATUTORY WARRANTIES AND ALL IMPLIED WARRANTIES, INCLUDING ANY IMPLIED WARRANTY OF MERCHANTABILITY OR FITNESS FOR A PARTICULAR PURPOSE.

FCC Compliance Statement:

LED POWER FAILURE NIGHT LIGHT

Model: LM030164

Responsible Party:

Koda

Address: 2975 Red Hill Ave., Ste. 100, Costa Mesa, CA 92626, USA

Tel: 1-866-294-9244

This device complies with Part 15 of the FCC rules. Operation is subject to the following two conditions: (1) this device may not cause harmful interference, and (2) this device must accept any interference received, including interference that may cause undesired operation.

Warning: Changes or modifications to this unit not expressly approved by the party responsible for compliance could void the user's authority to operate the equipment.

The manufacturer is not responsible for any radio or TV interference caused by unauthorized modifications or change to this equipment. Such modifications or change could void the user's authority to operate the equipment. This equipment has been tested and found to comply with the limits for a Class B digital device, pursuant to part 15 of the FCC Rules. These limits are designed to provide reasonable protection against harmful interference in a residential installation. This equipment generates, uses and can radiate radio frequency energy and, if not installed and used in accordance with the instructions, may cause harmful interference to radio communications. However, there is no guarantee that interference will not occur in a particular installation. If this equipment does cause harmful interference to radio or television reception, which can be determined by turning the equipment off and on, the user is encouraged to try to correct the interference by one or more of the following measures:

- Reorient or relocate the receiving antenna.
- Increase the separation between the equipment and receiver.
- Connect the equipment into an outlet on a circuit different from that to which the receiver is connected.
- Consult the dealer or an experienced radio/TV technician for help.

MADE IN CHINA

Distributed by:
Costco Wholesale Corporation
P.O. Box 34535
Seattle, WA 98124-1535
USA
1-800-774-2678
www.costco.com

Costco Wholesale Canada Ltd.*
415 W. Hunt Club Road
Ottawa, Ontario
K2E 1C5, Canada
1-800-463-3783
www.costco.ca

* faisant affaire au Québec sous le nom les Entrepôts Costco

Importado por:
Importadora Primex S.A. de C.V.
Blvd. Magnocentro No. 4
San Fernando La Herradura
Huixquilucan, Estado de México
C.P. 52765
RFC: IPR-930907-S70
(55)-5246-5500
www.costco.com.mx

Costco Wholesale Australia Pty Ltd
17-21 Parramatta Road
Lidcombe NSW 2141
Australia
www.costco.com.au

Costco Wholesale UK Ltd /
Costco Online UK Ltd
Hartspring Lane
Watford, Herts
WD25 8JS
United Kingdom
01923 213113
www.costco.co.uk

Costco Wholesale Spain S.L.U.
Polígono Empresarial Los Gavilanes
C/ Agustín de Betancourt, 17
28906 Getafe (Madrid) España
NIF: B86509460
900 111 155
www.costco.es

Costco Wholesale Iceland ehf.
Kauptún 3-7, 210 Gardabaer
Iceland
www.costco.is

Costco France
1 avenue de Bréhat
91140 Villebon-sur-Yvette
France
01 80 45 01 10
www.costco.fr

Costco Wholesale Japan Ltd.
2 Kakuchi, 2 Gaiku
Readjustment Area, Kaneda-Nishi
361 Urakura, Kisarazu-shi
Chiba, 292-0007 Japan
0570-200-800
www.costco.co.jp

Costco Wholesale Korea, Ltd.
40, Ijikk-ro
Gwangmyeong-si
Gyeonggi-do, 14347, Korea
1899-9900
www.costco.co.kr

Costco Wholesale New Zealand Limited
2 Gunton Drive
Westgate
Auckland 0814
New Zealand

Costco (China) Investment Co., Ltd.
Room 1003, Block 2, 2388 Xiupu Road,
Pudong New Area, Shanghai
China 201315
+86-21-6257-7065

Costco Wholesale Sweden AB
Mailbox 614
114 11 Stockholm
Sweden
www.costco.se

Have a comment or question? Email us at info@kodabuilt.com or visit us online at www.KodaBuilt.com

KODA™

A Horizon Brands Company
2975 Red Hill Ave., Ste. 100, Costa Mesa, CA 92626, USA | Tel: 1-866-294-9244
© 2022 Koda. All rights reserved.

ML-030164_V1