



G4 Seraphim[®] Digital Coffee Brewing System



READ AND SAVE THESE INSTRUCTIONS

NOTICE TO INSTALLER: Please leave this booklet with the machine.

Key Features/Specifications/System Requirements..... FS18

Important Safeguards..... IS2

Installation Instructions (General).....II2

Installation Instructions (Leveling, Water Supply, Electrical)II12

Operating InstructionsOI15

Cleaning Instructions (Brewer) CI1

Cleaning Instructions (Brew Basket) CI10

Programming Guide PG1

Rough-In Drawing..... RD24

Illustrated Parts/Recommended Parts (Main Chassis)..... IP27

Illustrated Parts/Recommended Parts (Tank Assembly) IP28

Electrical Schematic (Domestic)ES25

Electrical Schematic (Export)ES26

Troubleshooting GuideTG12

Troubleshooting GuideTG7

Troubleshooting GuideTG11

Error CodesEC1

Product Warranty.....PW1

Contact Information

Wilbur Curtis Co., Inc.

6913 Acco Street | Montebello, CA 90640 US
 Phone: 323-837-2300 | Toll Free: 800-421-6150
 Email: cstrassistance@wilburcurtis.com | Web: www.wilburcurtis.com

For the latest specifications and information go to www.wilburcurtis.com
 Toll Free: 800-995-0417 | Monday - Friday 5:30 A.M. - 4:00 P.M. PT
 Email: techsupport@wilburcurtis.com

Due to continued product improvement, the products illustrated/photographed in this guide may vary slightly from the actual product.

Key Features

- Standard Seraphim® package includes two Seraphs (brew heads), one Curtis 5.0 gallon hot water tower, G4 touchscreen and a drip tray assembly.
- Brewing methods – Chemex, Kalita, V60, Bee Dripper, Able Kone Brewing System, French Press and more.
- Temperature stability and flow rate; reliable, highly stable temperature and flow rate. Just set it and forget it.
- No cavitation – stable environment eliminates low pressure pockets.

Specifications (Selected Models)

Electrical Supply Requirements

MODEL #	DESCRIPTION	PHASE	VOLTS	AMPS	HEATING CONFIG	WIRE	WATTS	HERTZ	GAL/HR
SERA2B/ SERA2W	Twin Seraphim Single Cup Brewer, Black/White, Domestic	1 PH	110/220 V	12.5/22.7 A	2 X 2500 W	2W/3W + G	1500/5000 W	50/60 Hz	4.3/10.0
SERA2B30/ SERA2W30	Twin Seraphim Single Cup Brewer, Black/White, Export	1 PH	230 V	23.9 A	2 X 2500 W	2W + G	5500 W	50/60 Hz	5.0

Dimensions

Water Supply Requirements

MODEL #	HEIGHT	WIDTH	DEPTH	SHIP WEIGHT	SHIP CUBE	WATER CONNECTOR	WATER PRESSURE	MIN. FLOW RATE
SERA2B/ SERA2W	24.49" ¹ 16.08" ² 3.54" ³	11.07" ¹ 7.06" ² 7.18" ²	22.25" ¹ 17.58" ² 3.98" ³	76.0 lbs ⁴	6.53 cu ft ¹ 2.34 cu ft ² 0.35 cu ft ³	1/4" flare	20 - 90 psi	2.0 gpm
SERA2B30/ SERA2W30	24.49" ¹ 16.08" ² 3.54" ³	11.07" ¹ 7.06" ² 7.18" ²	22.25" ¹ 17.58" ² 3.98" ³	76.0 lbs ⁴	6.53 cu ft ¹ 2.34 cu ft ² 0.35 cu ft ³	1/4" flare	20 - 90 psi	2.0 gpm

¹ Water tower

² Heads

³ Universal Control Module (UCM)

⁴ Total

Following are the factory default settings for the Seraphim brewer:

- Brew Temperature = 200°F
- Minimum Brew Temperature = 185°F
- Energy Save Mode = Off

Symbols



This is the safety alert symbol. It is used to alert you to potential physical injury hazards. Obey all safety messages that follow this symbol to avoid possible injury or death.



DANGER - Indicates a hazardous situation which, if not avoided, will result in death or serious injury.



WARNING - Indicates a hazardous situation which, if not avoided, could result in death or serious injury.



CAUTION - Indicates a hazardous situation which, if not avoided, could result in minor or moderate injury.



NOTICE - Indicates a situation which, if not avoided, could result in property damage.



IMPORTANT - Provides information and tips for proper operation.



SANITATION REQUIREMENTS



WARNING - This product can expose you to chemicals including Acrylamide and Bisphenol A (BPA), which are known to the State of California to cause cancer and birth defects or other reproductive harm. For more information visit www.P65Warnings.ca.gov.

Important Safeguards/Conventions



WARNING:

- Make sure that this appliance is installed and grounded according to the INSTALLATION INSTRUCTIONS by qualified personnel before attempting to use it. Failure to follow the INSTALLATION INSTRUCTIONS could result in personal injury or void the warranty.
- This appliance is designed for commercial use. Any service other than cleaning and preventive maintenance should be performed by an authorized Wilbur Curtis service technician.
- To reduce the risk of fire or electric shock, DO NOT open the service panels. There are no user serviceable parts inside.
- Keep hands, arms and other items away from hot surfaces of the unit during operation.
- Clean the appliance and any dispensers completely before using them for the first time according to the CLEANING INSTRUCTIONS. Clean them regularly as instructed in the CLEANING INSTRUCTIONS.
- Use this appliance only for its intended use, brewing/dispensing hot and/or cold beverages/water.
- This appliance is not intended for use by persons (including children) with reduced physical, sensory or mental capabilities or lack of experience and knowledge, unless they have been given supervision or instruction concerning use of the appliance by a person responsible for their safety. Children should be supervised to ensure that they do not play with the appliance.
- Avoid spillage onto the power (mains) connector.

CE Requirements

- This appliance must be installed in locations where it can be overseen by trained personnel.
- For proper operation, this appliance must be installed where the temperature is between 5°C to 35°C.
- Appliance shall not be tilted more than 10° for safe operation.
- An electrician must provide electrical service as specified in conformance with all local and national codes. For safe use, an all-pole disconnection must be incorporated into the fixed wiring in accordance with the wiring rules outlined in clause 7.12.2 of IEC 6.335-1 for meeting the minimum electrical safety of this standard.
- This appliance must not be cleaned by water jet.
- This appliance can be used by persons aged from 18 years and above if they have been given supervision or instruction concerning use of the appliance in a safe way and if they understand the hazards involved.
- Keep the appliance and its cord out of reach of children aged less than 18 years.
- Appliances can be used by persons 18 years and above with reduced physical, sensory or mental capabilities or lack of experience and knowledge if they have been given supervision or instruction concerning use of the appliance in a safe way and understand the hazards involved.
- Children under the age of 18 years should be supervised to ensure they do not play with the appliance.
- If the power cord is ever damaged, it must be replaced by the manufacturer or authorized service personnel with a special cord available from the manufacturer or its authorized service personnel in order to avoid a hazard.
- Machine must not be immersed for cleaning.
- Cleaning and user maintenance shall not be made by children unless they are older than 18 years and supervised.
- This appliance is intended to be used in household and similar applications such as:
 - staff kitchen areas in shops, offices and other working environments;
 - by clients in hotels, motels and other residential type environments;
 - bed and breakfast type environments.
- This appliance not intended to be used in applications such as:
 - farm houses
- Access to the service areas permitted by Authorized Service personnel only.
- The A-Weighted sound pressure level is below 70 dBA.



WARNING: Installation is to be performed only by a qualified installer.



WARNING: Improper electrical connection may result in an electric shock hazard. This brewer must be properly grounded.



NOTICE: DO NOT connect this brewer to a hot water supply. The water inlet valve is not rated for hot water. Do not exceed the maximum water pressure stated in the *SPECIFICATIONS* section.



IMPORTANT: Observe all governing codes and ordinances.

Installation Instructions

Installation Requirements

- A secure surface capable of supporting the weight of the appliance.
- For units without an attached cord set: Appropriately sized, UL listed, grounding type power cable to meet the electrical specifications for the appliance. If you have questions about the correct cable size and length, consult a qualified installer. If the appliance will be hard wired to a junction box, the power cable must be long enough so that the unit can be moved for cleaning underneath.
- A grounded electrical connection to an electrical circuit that meets the electrical specifications of the appliance (see *SPECIFICATIONS*). The circuit must be protected by the appropriate sized circuit breaker. If you are not certain that the existing circuit meets the requirements for your unit, consult a licensed electrician.
- A water filtration system is required to maintain trouble-free operation. Wilbur Curtis Co., Inc. recommends a Wilbur Curtis approved water filter. See the Curtis Equipment Catalog for a full line of Wilbur Curtis approved water filters.
- Potable water supply line connection from the water filter capable of supplying the minimum flow rate required by the specifications. The water supply line must be able to connect to the flare fitting on the back of the unit. See the *SPECIFICATIONS* section for the correct size. The water line should also be capable of being controlled by a shut off valve. Do not connect the water line to a saddle valve or needle valve.



NSF International requires the following water connection:

- 1 A quick disconnect or additional coiled tubing (at least two times the depth of the appliance) is required so that it can be moved for cleaning underneath.
- 2 This equipment is to be installed with adequate back-flow protection to comply with applicable federal, state and local codes.
- 3 Water pipe connections and fixtures directly connected to a potable water supply shall be sized, installed and maintained in accordance with federal, state and local codes.

The International Plumbing Code of the International Code Council and the Food and Drug Administration (FDA) Food Code manual, direct that this equipment must be installed with adequate back-flow prevention in compliance with federal, state and local codes. For units installed outside of the U.S.A., make sure that the installation is in compliance with the applicable plumbing/sanitation code for your area.

Installation

Connect the Power Cord to the Brewer



WARNING: Make sure power to the circuit supplying power to the water tower is turned off at the circuit breaker panel until installation is complete. Lock out and tag the circuit breaker.

- 1 Place the water tower on a sturdy surface. Remove the top and side covers.
- 2 If the brewer will be operating using 120 Vac, locate the jumper on the terminal block inside the water tower and remove the cap, then connect the end of the jumper wire to the L2 terminal on the terminal block.
- 3 Loosen the strain relief on the back of the brewer.
- 4 Feed the end of the power cord into the strain relief.
- 5 Connect the wires on the power cable to the terminal block inside the brewer.
- 6 Tighten the strain relief. Leave the covers off until all the water tower connections are made, later in the installation process.

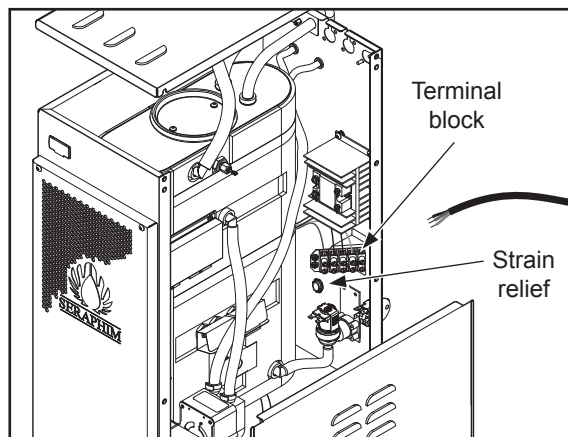

Figure 1 - Power Cord Connection

Prepare the Countertop

- 7 Holes must be cut into the counter top prior to installing the brewer. The hole pattern is critical for proper operation. See **Figure 3** on the following page. The two brew heads must fit within a 2 foot by 3 foot area.

Packed with the unit is a full-size template (Part # WC-390245). Use the template for cutting the required holes needed for installing the brew heads, touchscreen and drip tray. The two largest circular holes are for the brew head assemblies, along with three stud holes for the mounting plate for each head. Also, there is a circular hole for the touch screen, along with the two mounting holes. The drip tray can be inset into the counter or mounted flush. Inset installation is recommended. The rectangular hole shown in **Figure 3** is for inset installation. If the drip tray will be mounted flush, a circular hole is drilled in the location shown for the drain instead of a rectangular hole.

Consideration must be made for the drip tray drain system. The drip tray comes with a 1/2" NPT X 3" nipple and a 1/2" NPT barbed elbow. Either may be used to connect the drain system (supplied by the purchaser) to the bottom of the drip tray. See **Figure 4** on the following page for dimensions.

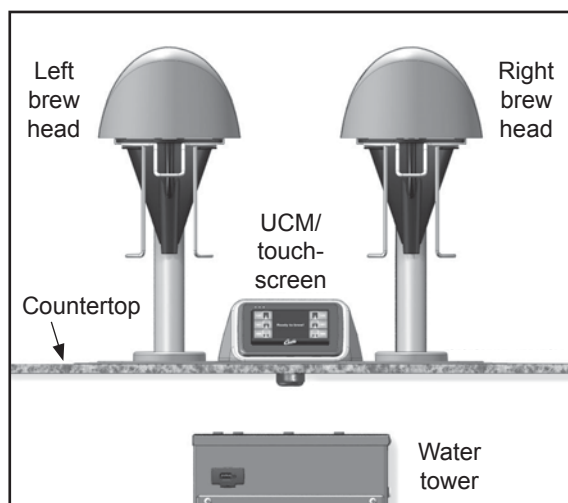

Figure 2 - Parts of the Brewing System (Front View)

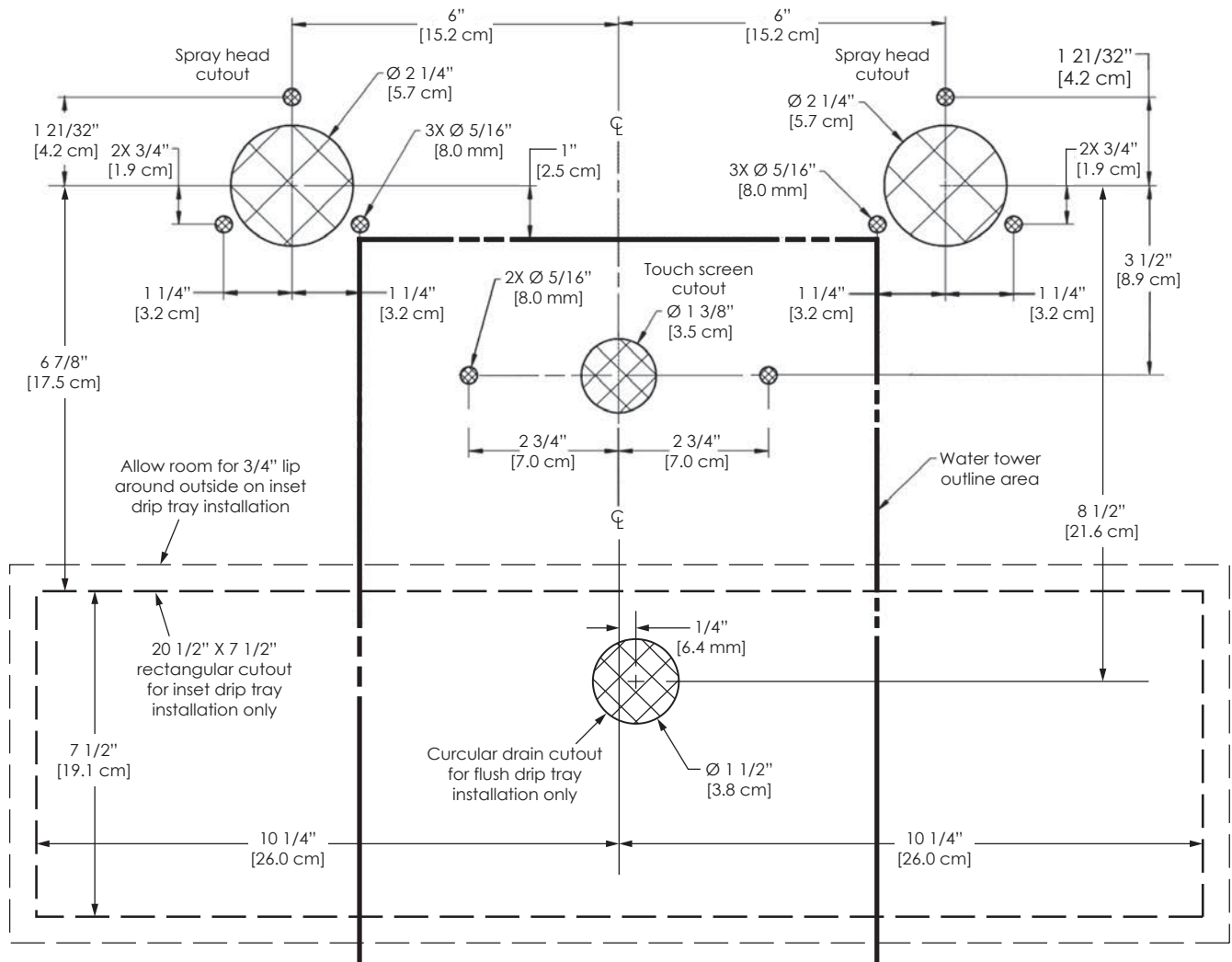

Figure 3 - Hole Pattern Template for Cutting and Drilling Countertop (Drawing Not to Scale)

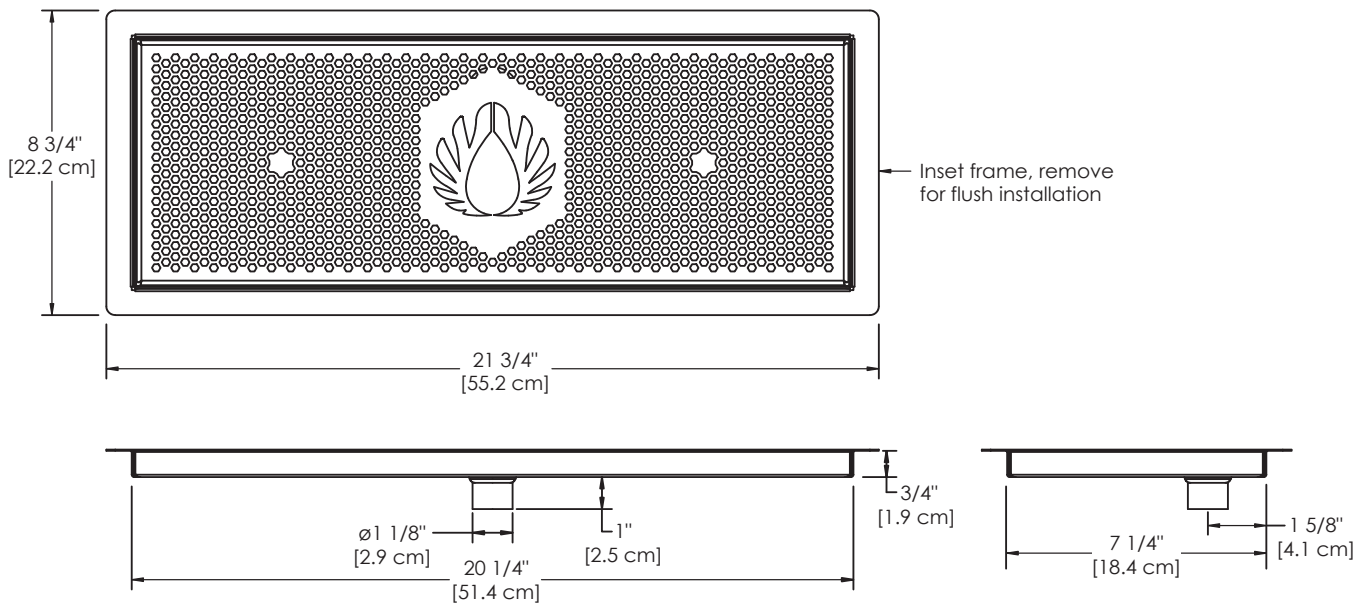

Figure 4 - Drip Tray Dimensions

Install the Drip Tray

- 8 After preparing the drip tray location, according to Step 7, apply Teflon plumbing tape to the threads of the supplied pipe nipple (or barbed elbow)* and thread into the bottom of the drip tray. Assemble the drip tray pieces as shown and place them into position.

*The elbow may only be used on drip tray installations that are open wide enough on the bottom to allow access to the barb connection.

- 9 Install the drain system. Be sure to allow room under the countertop for the water tower.

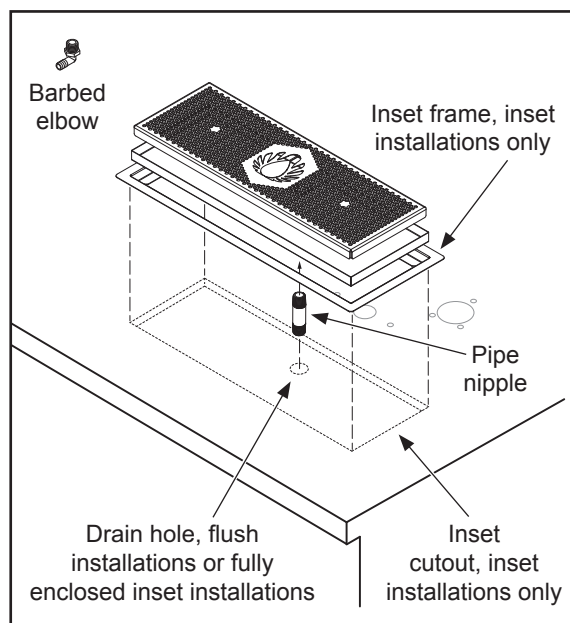

Figure 5 - Drip Tray Installation

Install the Brew Heads

Install the brew head assemblies into the countertop in the correct position. One brew head is designed to be installed on the right side and the other on the left. The installation position for each brew head is marked on the attached wires and tubes. Each brew head has three 1/4-20 studs with matching nuts and washers for mounting onto the surface of the counter.



CAUTION: Do not open the brew head units! The length of the wires and tubing are fixed and set at the factory. Do not splice or extend the tubes that come from beneath the brew head assembly. Ample tube length is provided and the tubes will need to be shortened in most cases for proper installation.

- 10 Hold a brew head over the group of holes that matches the markings on the brew head tubing/wiring (right or left).
- 11 Insert the tubes and wires into the large center hole and insert the studs through the three smaller holes, while pushing the unit down onto the counter top.
- 12 Secure using one (1) fender washer, one (1) lock washer and one (1) nut per threaded stud. Repeat for the other brew head.

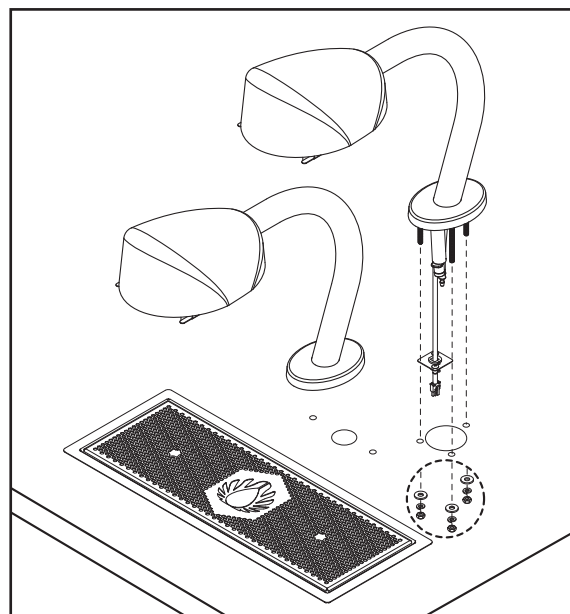

Figure 6 - Brew Head Installation

Place the Water Tower Under the Countertop

- 13 Place the water tower on the floor of the cabinet below the counter top. Wait to install the hold down brackets until instructed to do so. The water tower may need to be moved around to allow access to the bottom the UCM assembly and the brew heads as they are installed.

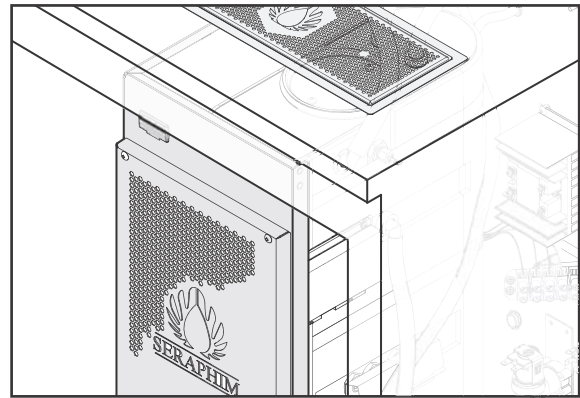

Figure 7 - Water Tower Placement

Install the UCM Assembly

- 14 Locate the wiring harness and UCM plugs coming from behind the water tower. Push the plugs up through the touchscreen cutout in the countertop and plug them into the receptacles in back of the UCM. These will snap and lock into place.
- 15 Install the UCM and holder onto the countertop. Slip the two 1/4-20 threaded studs into the countertop and fasten the holder to the counter using one (1) fender washer, one (1) lock washer and one (1) nut per threaded stud.

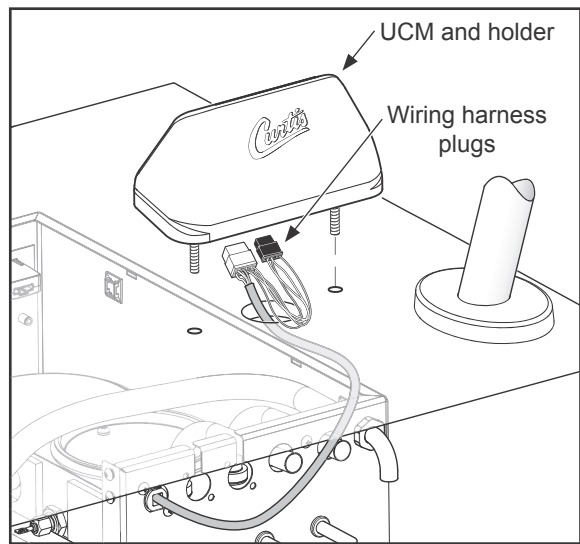

Figure 8 - UCM Installation

Install the Water Tower

- 16 Remove the screws from the cable support plates, attached to the control cables coming from the brew heads. Insert the cable support plates into the slots on the back of the chassis. Run the cables through the holes. The cables for the right and left brew heads route through the two cable ports on the right. The left port is for the UCM controller cable.

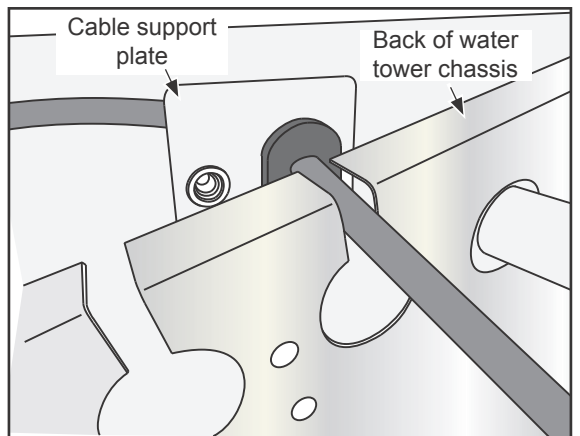

Figure 9 - Inserting Cable Support Plates

Install the Water Tower (cont.)

- 17 Use the screws to attach the plates to the chassis as shown.
- 18 Connect the brew head cables to the connectors inside the chassis. The connectors are labeled right and left to indicate the correct cable connection.
- 19 Replace the water tower top cover and side cover.

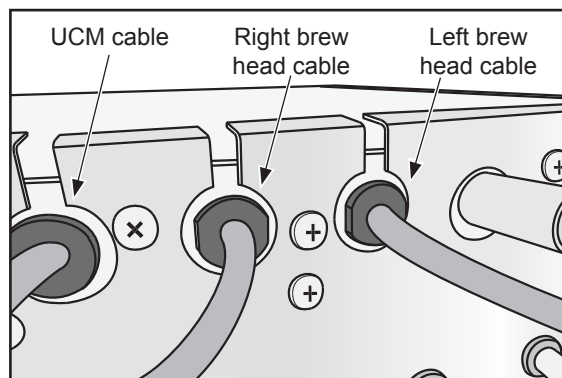

Figure 10 - Attached Cable Support Plates

Level the Water Tower



WARNING: Use the leveling legs to level the water tower only. Do not use them to adjust the height. Do not extend them higher than necessary.

- 20 Center the water tower between the two brew heads under the countertop. Refer to the hole pattern drawing (Figure 3) for the proper location. Level it left to right and front to back by turning the bottom of the legs.

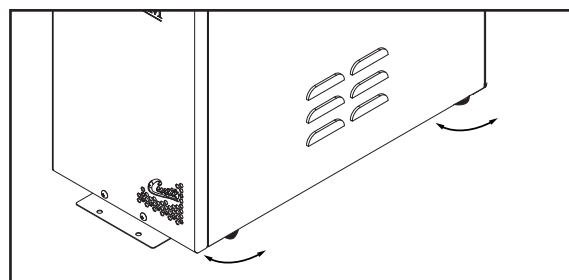

Figure 11 - Leveling the Water Tower

Connect the Brew Head Water Return and Supply Lines



WARNING: The water return lines must not sag. Route them in a downhill orientation between the bottom of the brew head assemblies and the back of the water tower (see Figure 13). The tubing can be shortened if necessary to make sure that the lines are free of sag that will trap water inside them between the brew heads and the water tower.

- 21 Link the brew heads to the water tower by attaching the water return lines. These are the two larger diameter flexible silicone tubes that come from behind the water tower. The matching return lines from the spray head assemblies will have a straight fitting slipped into the end of the tube. Join the return line tubes together using this fitting. Make sure they are correctly oriented as shown in Figures 12 and 13.
- 22 Locate the two (2) 1/4 inch diameter water supply lines behind the water tower. Shorten them to minimize length when connected with the matching 1/4 inch tubing coming from the bottom of the brew head assemblies.
- 23 Insert the water supply tubes from the back of the water tower into the barbed connector on the supply line tube fittings from the brew head assemblies. See Figure 12.

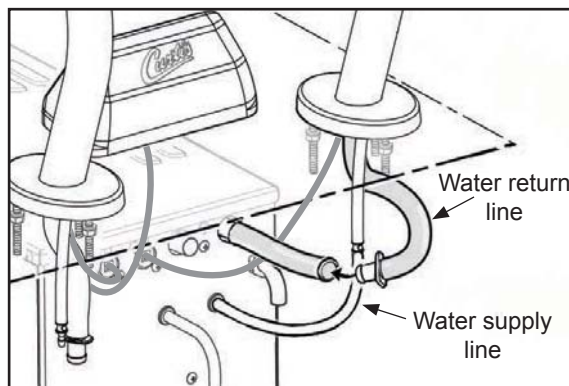

Figure 12 - Attaching the Water Hoses

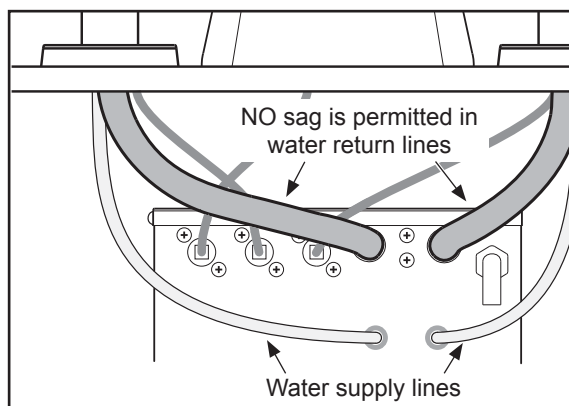

Figure 13 - Return Line Installation

Install the Exhaust Lines



NOTICE: The exhaust line tubing must be installed so that ends do not become submerged in water to avoid backup.

24 The water tower is equipped with two outlet fittings that vent steam and condensation from the water tank inside the chassis. Run the provided exhaust line tubing from these fittings to a drain to drain off condensation.

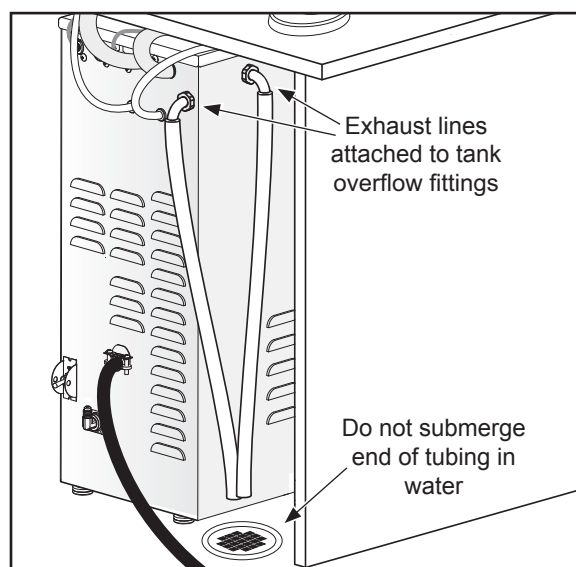

Figure 14 - Exhaust Line Installation

Connect the Water Supply

- 25 Flush the water supply line prior to installation to purge air and debris from the water filter and tubing.
- 26 Connect the water supply line to the flare fitting on the back of the brewer. Leave the water supply valve closed until the power is connected.

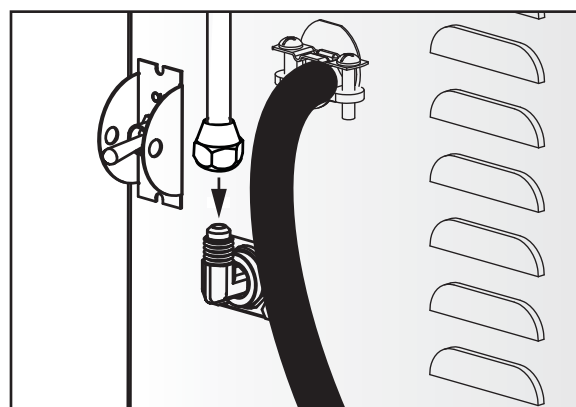

Figure 15 - Water Supply Connection

Install the Hold Down Brackets

The water tower must be secured to the bottom of the cabinet using the hold down brackets affixed to the bottom edges of the chassis.



WARNING: Failure to install the hold down brackets may cause the unit to tip over, especially when installed in a mobile coffee counter. Injury might result from spilled hot liquids or damage may occur to the water tower itself.

27 Fasten the water tower brackets onto the floor. There is one on the front and one on the side. If the brewer is installed in a different location later, these brackets must also be moved and installed with the water tower.

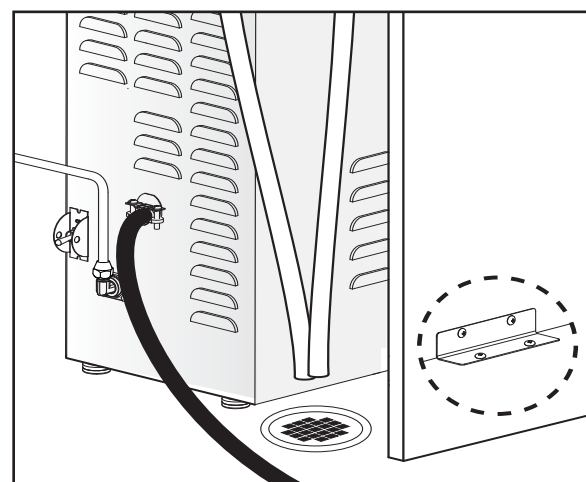

Connect the Power Cord

28 For 220 Volt units, connect the power cable wires to the terminals in the junction box. On brewers set up for 120 Volts, connect the power cord to the appropriate electrical outlet. See the *ELECTRICAL SCHEMATIC* for the power supply requirements.



WARNING: If using a 120 Volt power cord, connect the power cord to the appropriate type and size electrical outlet. If the electrical outlet is not compatible with the power cord, have it upgraded by a licensed electrician. Do not modify the power plug. Do not use an extension cord. Do not use a power cord/plug that is damaged.

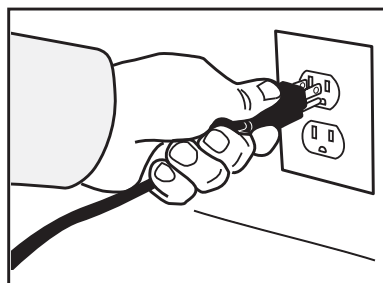

Power Up the Brewer

- 29 Turn on the water supply valve.
- 30 Make sure that the circuit breaker supplying power to the circuit is on.
- 31 Turn the toggle switch on the back of the water tower to the ON position. The water tank will start to fill. While the tank is filling, inspect the water supply line for leaks.
- 32 When the water in the tank rises to the correct level, the heating elements will turn on automatically. Depending on the incoming water temperature and the electrical specifications, the water tank typically requires 45 minutes to reach the factory set operating temperature. When the water has heated, "Ready to brew" will appear on the LCD screen.

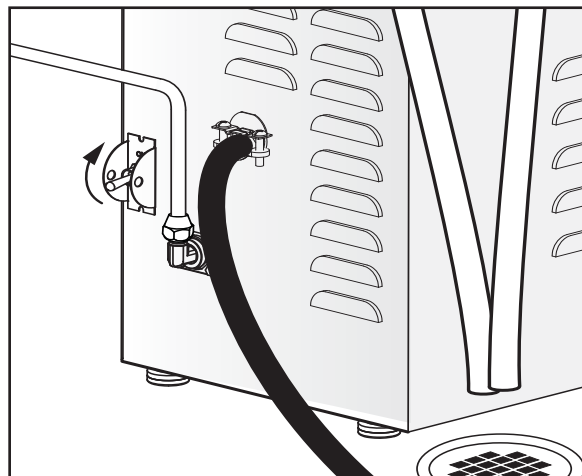

IMPORTANT: When operating the brewer at higher elevations, reduce the factory set operating temperature by 2°F (1°C) for each 1000 feet (300 m) of elevation above 4000 feet (1200 m). See *PROGRAMMING GUIDE*.

33 Perform a brew cycle of a least 12 ounces to purge any remaining air from the system. See *OPERATING INSTRUCTIONS*. During the initial brew cycle and whenever the filter is replaced, you may hear the sounds of air being purged from the filter, tubing and water tank.

Installing the Optional Brew Basket Holder

- 34 Make sure the toggle switch on the back of the water tower is in the off position.
- 35 Thread the shaft of the brew basket holder into the hole (located toward the back) on the underside of one of the brew heads. Hand tighten into place.

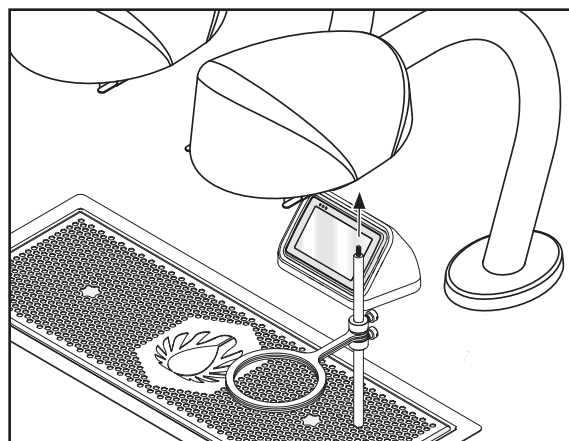

Brewing Instructions - Single Cup

WARNING - TO AVOID SCALDING, AVOID SPLASHING. Keep body parts clear of the brewer during brewing. Do not remove the brew basket while “Brewing” appears on the display.

The G4 Seraphim Brewer is factory preset for optimal performance.

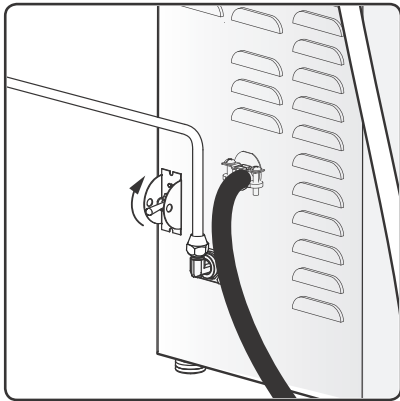

1 The brewer should be ON. Confirm this at the toggle switch on the back of the water tower. “Ready to brew” should be on the display.

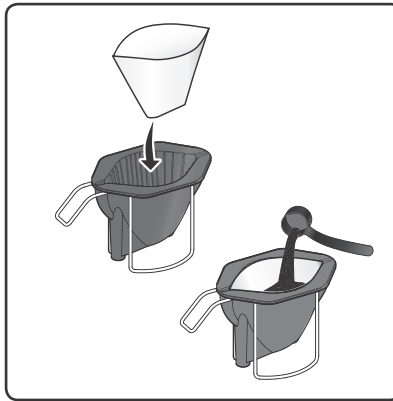

2 Insert a clean paper filter into the brew basket. Fill with the proper amount of coffee. Level the coffee in the filter.

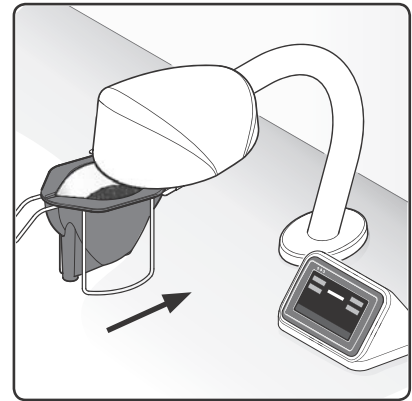

3 Slide the filled brew basket into the brew rails on the brew head. Slide it all the way back until it stops.



4 Center an empty coffee container beneath the brew head.

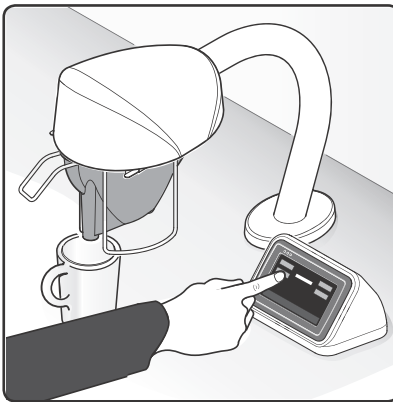

5 Hold your finger on the **Brew Basket** icon. As soon as you hear the click of the brew valve, lift your finger. Brewing will begin.

ENTER BREW CODE		
1	2	3
4	5	6
7	8	9
Del	0	OK

6 If a keypad appears on the display, the brew code feature is enabled (default is off). **Brewing will start immediately after you enter the brew code.** See the *PROGRAMMING GUIDE* to set up/disable the brew code.

The brewer will brew coffee based on the settings programmed into the universal control module (UCM). To change the settings, see the *PROGRAMMING GUIDE* section. During the brew cycle, an on screen brew timer will count down the time remaining.

Brewing Instructions - Drippers

WARNING - TO AVOID SCALDING, AVOID SPLASHING. Keep body parts clear of the brewer during brewing. Do not remove the brew basket while “Brewing” appears on the display.

The G4 Seraphim Brewer is factory preset for optimal performance.

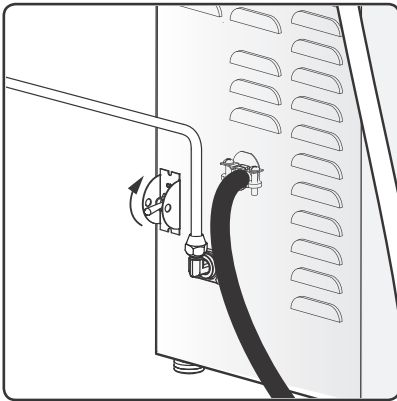

1 The brewer should be ON. Confirm this at the toggle switch on the back of the water tower. “Ready to brew” should be on the display.

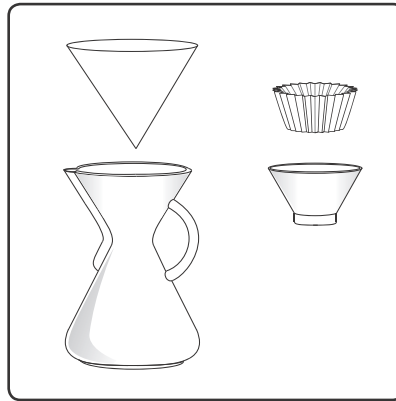

2 Insert a clean paper filter into the dripper.

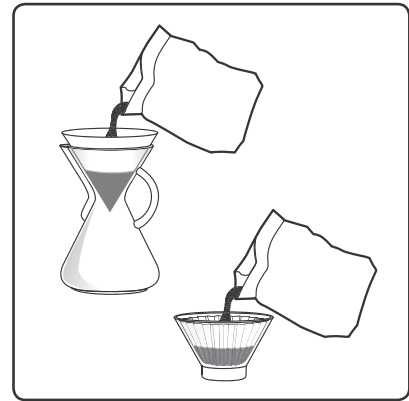

3 Fill the dripper with the proper amount of coffee. Level the coffee in the filter.

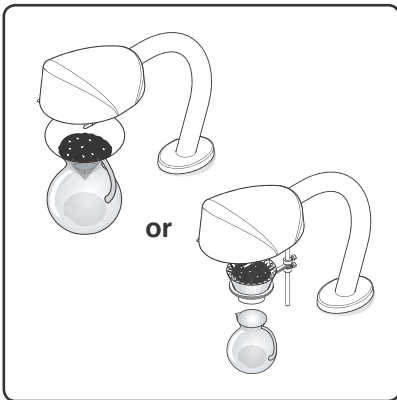

4 Remove the brew basket and center the dripper beneath the brew head. Use the brew basket ring for two piece drippers.*

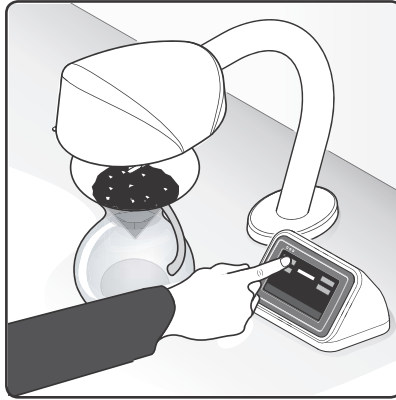

5 Hold your finger on the appropriate brew icon. As soon as you hear the click of the brew valve, lift your finger. Brewing will begin.

ENTER BREW CODE		
1	2	3
4	5	6
7	8	9
Del	0	OK

6 If a keypad appears on the display, the brew code feature is enabled (default is off). **Brewing will start immediately after you enter the brew code.** See the *PROGRAMMING GUIDE* to set up/disable the brew code.

The brewer will brew coffee based on the settings programmed into the universal control module (UCM). To change the settings, see the *PROGRAMMING GUIDE* section. During the brew cycle, an on screen brew timer will count down the time remaining.

* See *INSTALLATION INSTRUCTIONS* for brew basket ring installation instructions.



WARNING: HOT SURFACES - To avoid injury, allow the brewer and dispenser(s) to cool before cleaning.



NOTICE - Do not use cleaning liquids, compounds or powders containing chlorine (bleach) or corrosives. These products promote corrosion and will damage the finishes. **USE OF THESE PRODUCTS WILL VOID THE WARRANTY.**

Cleaning The Brewer - Daily



WARNING: DO NOT immerse the brewer in water or any other liquid.

The brewer should be OFF. Turn the brewer off by flipping the rear toggle switch to the OFF position.

- 1 Remove the dispenser(s). Wipe exterior brewer surfaces with a damp cloth to remove spills and debris.
- 2 Remove the brew basket(s) and clean them in a mild detergent solution. Use a soft bristled brush for hard to clean areas. Rinse with clean water, then dry.
- 3 Wipe the spray head area with a cloth soaked in a mild detergent solution. Rinse with a cloth soaked with clean water removing any residual detergent. Use a clean, soft cloth to dry.
- 4 Dump out the drip tray(s) (if applicable). Rinse with clean water, then dry with a soft, clean cloth.

Cleaning The Brewer - Weekly

The brewer should be OFF. Turn the brewer off by flipping the rear toggle switch to the OFF position.

- 1 Remove the spray head(s), unscrewing counterclockwise from the dome plate.
- 2 Thoroughly clean and rinse the dome plate area.
- 3 Clean the brew basket rails with a brush soaked with a mild detergent solution. Rinse the area with a cloth soaked with clean water, removing any residual detergent.
- 4 Dry the area with a soft, clean cloth.
- 5 Reattach the spray head(s).

Cleaning Single Cup Brew Baskets

Clean the dispensing spout of the brew basket once a month or more often in locations where the brewer gets heavy use.

- 1 Look into the brew basket to locate the cap covering the spout tube. Remove this cap by grasping the top portion and pulling it straight up.
- 2 Clean the inside orifice of the spout tube. For better cleaning, you can mix a mild dish washing solution to use while cleaning. Insert a small brush through the spout tube from the outside of the brew basket. Spin the brush a few times to remove any coffee residue. Look inside the brew basket and verify that the brush has gone completely through the spout.
- 3 Clean the small opening on the side of the spout tube. Insert the brush into the side opening and spin it a few times. Run the brush completely through the side opening.
- 4 Rinse the brew basket with clear water. Observe the flow of water from the dispensing spout to make sure you have a good flow. Replace the cap on top of the spout tube. Push down on the cap until it snaps into place.

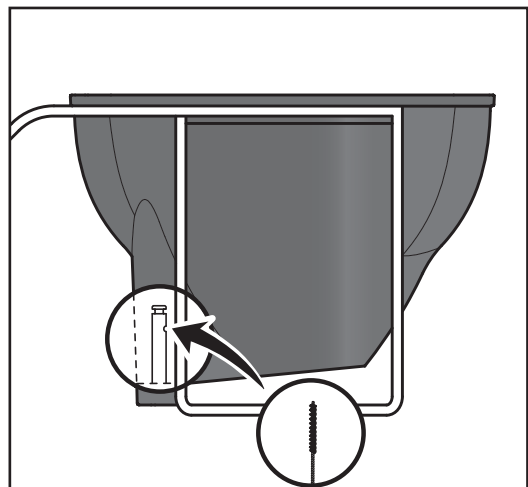
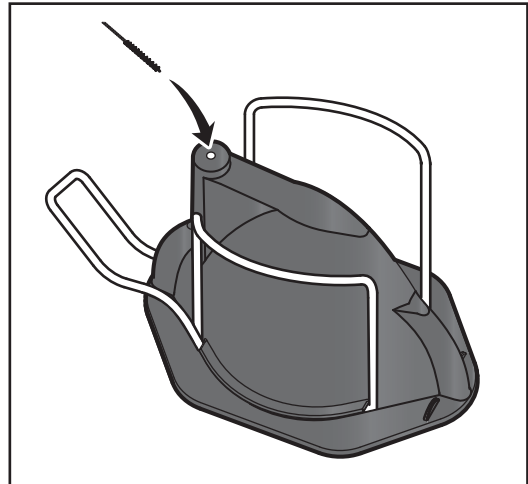
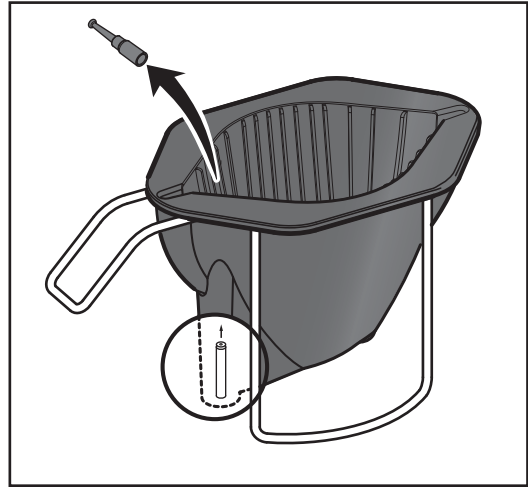

Touchscreen Control Module

The touchscreen turns on whenever power is provided to the brewer and the rear toggle switch is on. The symbol buttons on the screen control operation and programming. Pressing the on-screen symbols and buttons with your finger tip activates the various functions. The default screen, as well as additional control buttons are shown below. The configuration of the default screen varies depending on the brewer model.

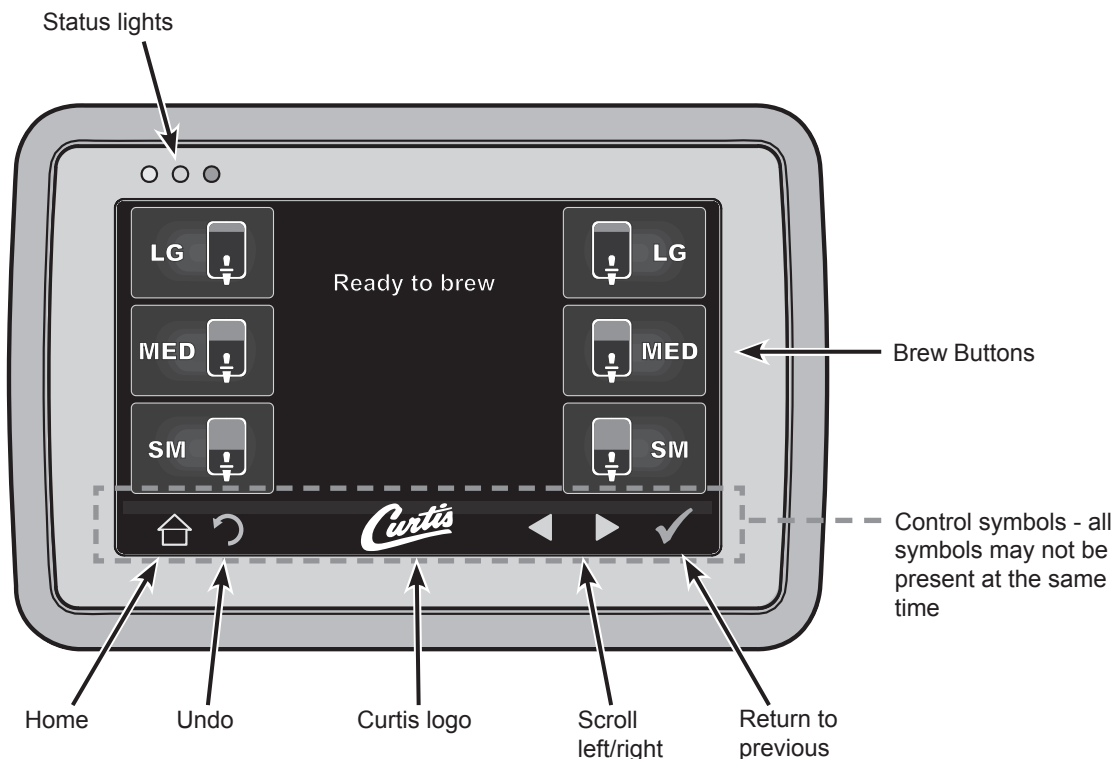

Entering Programming Mode

1 Tap the (white) Curtis logo on the touchscreen five (5) times to enter programming mode (see diagram above).

ENTER ACCESS CODE		
1234		
1	2	3
4	5	6
7	8	9
Del	0	OK

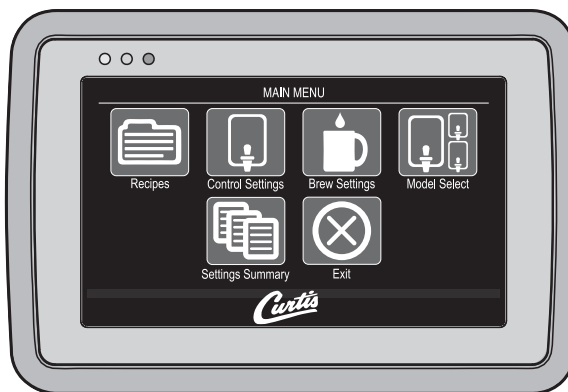

2 The ACCESS CODE screen will appear. The default pass code is 1 2 3 4. Once the code is entered, press OK. The MAIN MENU screen will appear. The access code can be reset in the Control Settings sub-menu, under Passwords.

3 The MAIN MENU screen contains a series of sub-menu icons. The icons vary based on the model selected under the Model Select sub-menu. For the brewer to operate properly, the model selected must match the model series on the brewer model number label affixed to the outside of the machine.

Programming

Shown below are the various programming options available in the programming MAIN MENU. The icons that appear vary based on the brewer model selected under Model Select.

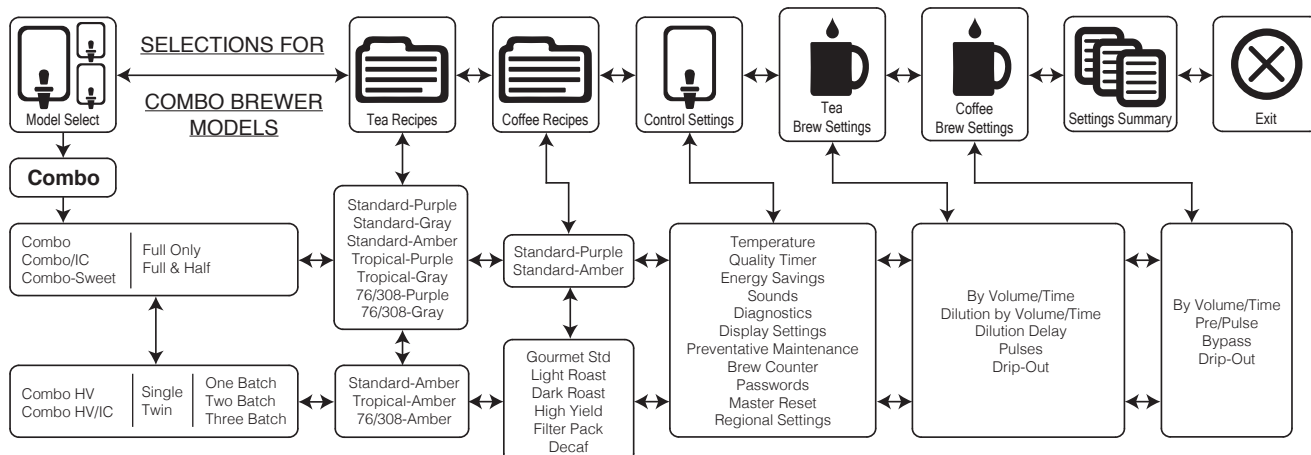
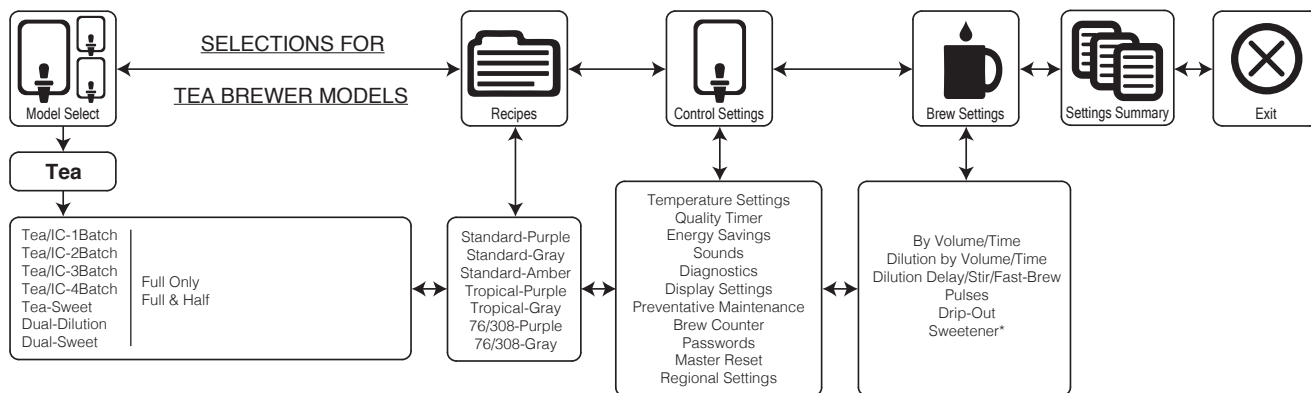
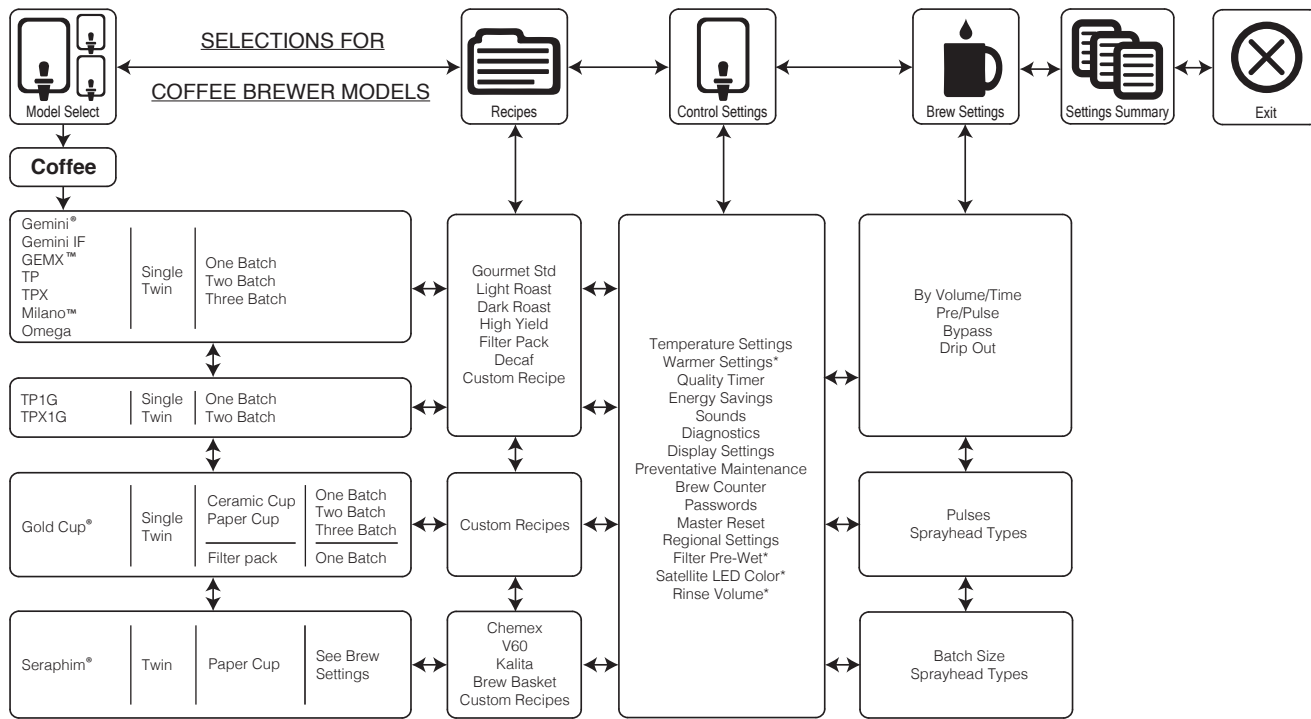

* Feature not available on some models

USB - Easy Programming

There are two methods for changing the default settings on G4 brewers. The settings can be programmed manually using the brewer touch screen, or automatically using the USB (Universal Serial Bus) data port on the side of the brewer. Using the USB connection and a flash drive easily reprograms the settings by simply copying data.

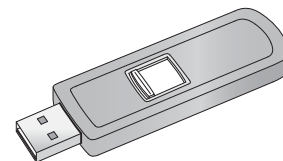

A flash drive can copy all of the settings from one identical G4 brewer to another. Doing so eliminates the need to program each step individually using the touchscreen. This process also makes it easy to quickly standardize the program settings on multiple G4 brewers.

Use a flash drive that supports USB 2.0 or above and has a type-A USB connection. The storage capacity must be 2 GB minimum.

i **IMPORTANT:** The flash drive must be completely blank. Erase any existing files on the drive before starting the following process.

Uploading the Software to the Flash Drive

- 1 Make sure the brewer is on. Check to make sure that the brewer you are copying settings from is programmed as desired.
- 2 Open the cover on the USB port and insert the connector on the empty flash drive. The port is located on the right side panel of the brewer, near the top. The universal control module (UCM) will upload all of the setup data onto the flash drive. The yellow LED icon on the top left of the touchscreen will light indicating that data is transferring. This process will only take a second to complete.

Downloading the Software to the Brewer from the Flash Drive

- 1 Select the (identical) brewer you wish to make program changes to. The brewer must be on.
- 2 Plug the loaded flash drive into the USB port on the brewer. The data copied from the first brewer will automatically download, overwriting all the settings that were on the second brewer.
- 3 The red LED on the top left of the touchscreen will indicate that the download is in process. This will only take a second.
- 4 Once the download is complete, the UCM will reboot so that the changes take effect.
- 5 Remove the flash drive. The download is complete. The data on the flash drive can continue to be downloaded into as many identical brewers as needed.

USB File Transfer

This screen will be present whenever the USB flash drive is inserted, provided the brewer is not currently brewing.

The default action is "No Action". The UCM will always create a backup on the flash drive before downloading settings/recipes or a screen-saver.

If a firmware update is present on the flash drive, the firmware update procedure will be started before the screen is shown.

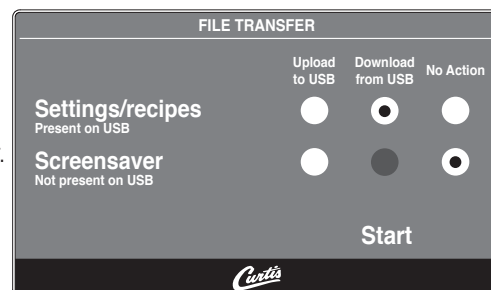

Seraphim - G4 Digital Brewing System

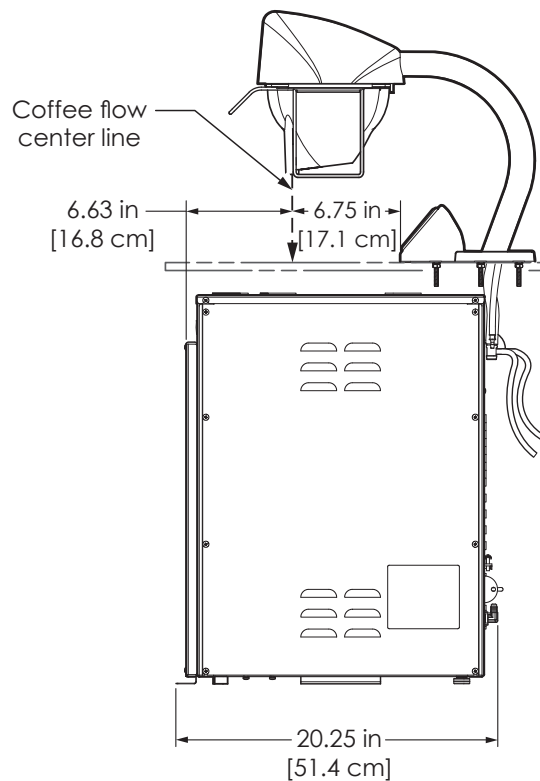
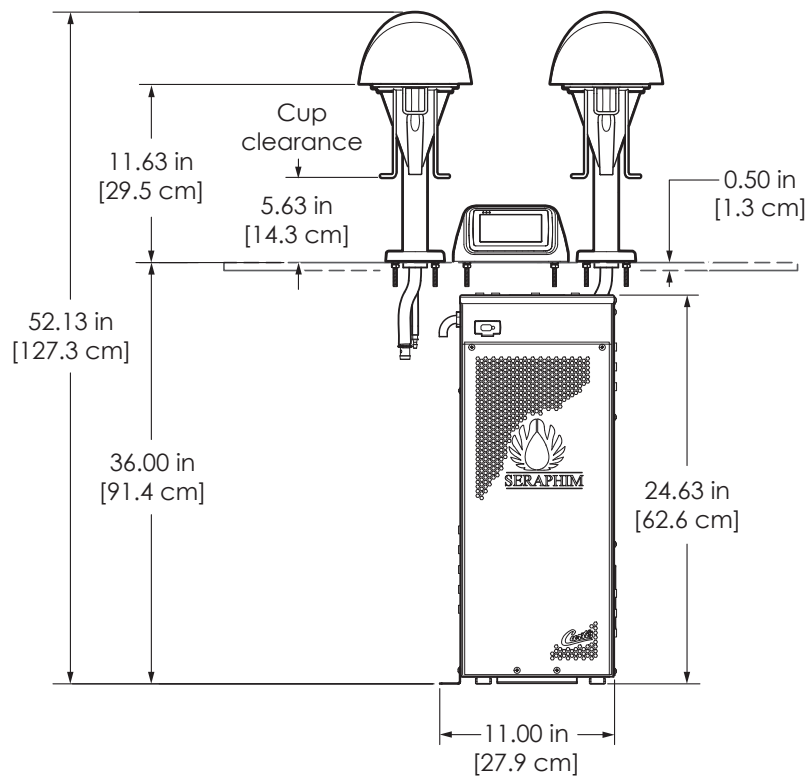
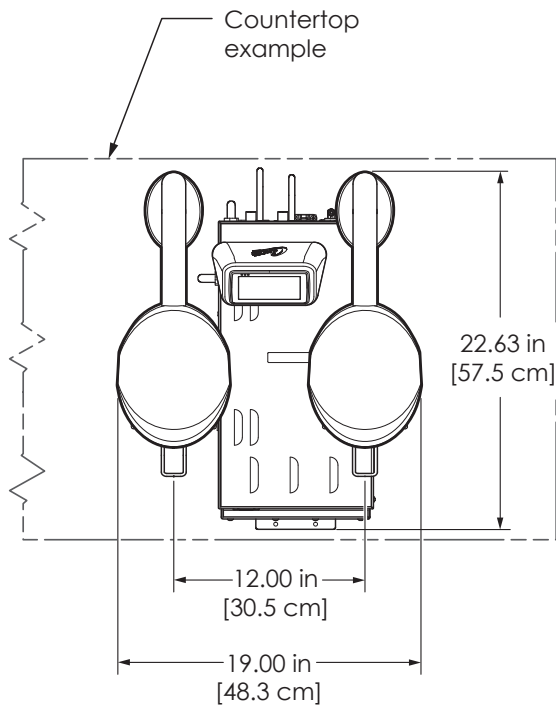

SERA2 - Main Chassis, Front - Exploded View

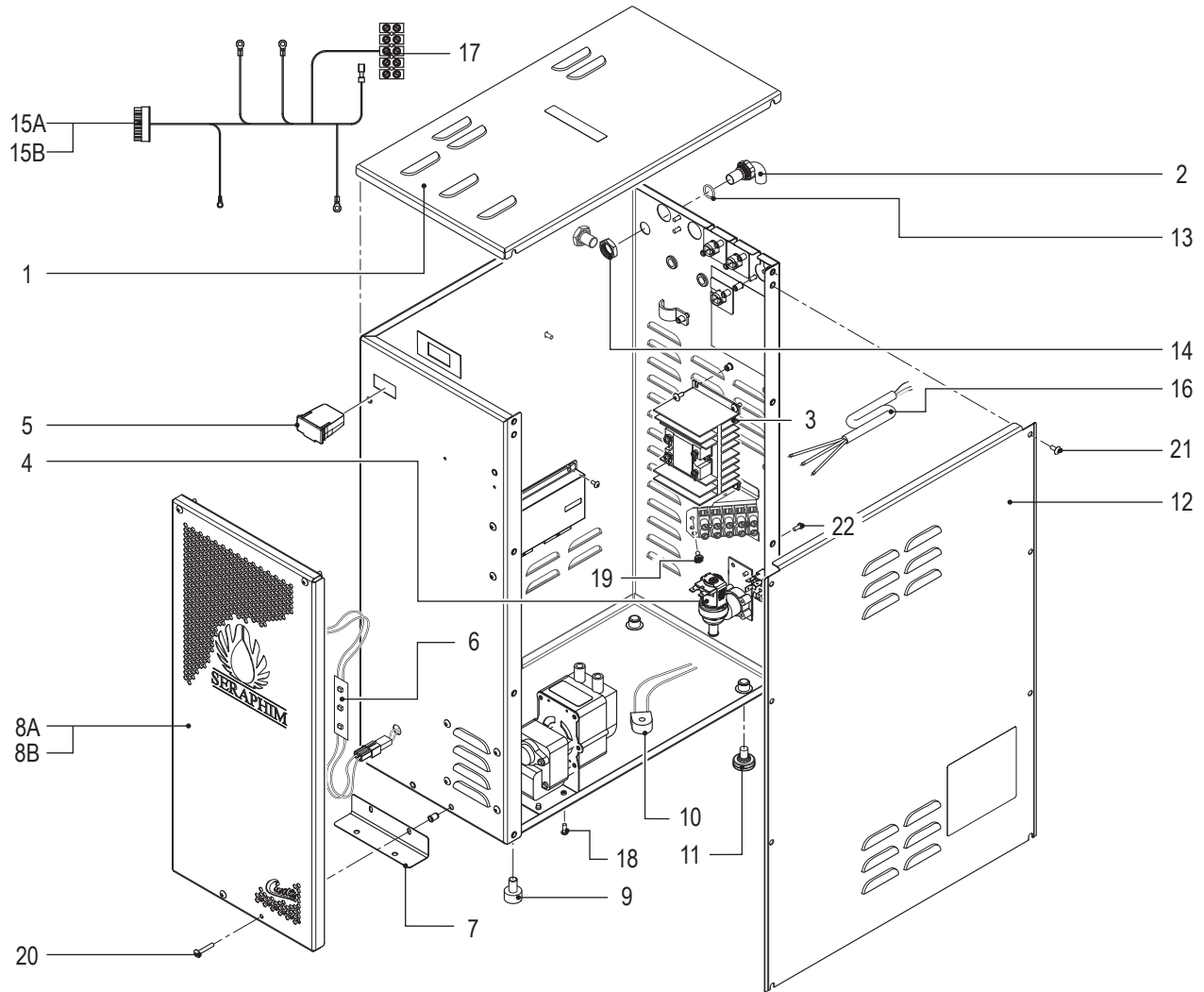

SERA2 - Main Chassis, Front - Parts List

ITEM #	PART #	DESCRIPTION
1	WC-61643	COVER, TOP SERAPHIM
2	WC-2948	FITTING, TANK OVERFLOW 304SST
3	WC-8559*	RELAY, SOLID STATE 280V/40A W/ HEATSINK AND QUICK DISCONNECTS
4	WC-847*	VALVE, INLET 2 GPM 120V 10W GEN USE BROWN BODY
5	WC-10008	UNIVERSAL HOST ADAPTER (USB-G4)
6	WC-1065	LED STRIP ASSY, 12Vdc x 1.2W 15 LEDs w/ CONNECTORS
7	WC-61536	BRACKET, SIDE
8A	WC-73133	PLATE, FRONT FACE SERAPHIM LOGO
8B	WC-73133K	KIT, ASSY FRONT FACE & LED SERAPHIM
9	WC-3503*	LEG, 3/8"-16 STUD SCREW BUMPER
10	WC-14045-101*	CURRENT SENSOR ASSEMBLY G4
11	WC-3518*	LEG, GLIDE 3/8"-16 STUD SCREW
12	WC-61521	COVER, SIDE ACCESS

ITEM #	PART #	DESCRIPTION
13	WC-4320*	O-RING, 1/2" I.D.
14	WC-4212	NUT, 5/8-18 JAM UNF SS
15A	WC-13521 ^a	HARNESS, ASSY SERAPHIM
15B	WC-13521-101 ^b	HARNESS, ASSY COMPLETE SERA30
16	WC-1250 ^b	CORD, 4mm ² 90°C 49A 450/750V 6 FT LG W/ FERRULES ONE END
17	WC-314	POWER BLOCK, 5 STATION
18	WC-4518	SCREW, 10-24x3/8 PHIL PAN HD SS GEN USE
19	WC-4509	SCREW, 10-32x3/8 SLTD HEX WSHR PH/ HD U.L. GROUND
20	WC-4433	SCREW, 8-32x1 1/4 PH TRUSS HD ST./STL.
21	WC-4426	SCREW, 8-32x3/8 PH HEAD TRUSS
22	WC-4616	SCREW, 1/4-20 x 1/2 PHILLIPS PAN HEAD STAINLESS STEEL

*Recommended parts to stock

^a Domestic units

^b Export units

SERA2 - Main Chassis, Rear - Exploded View

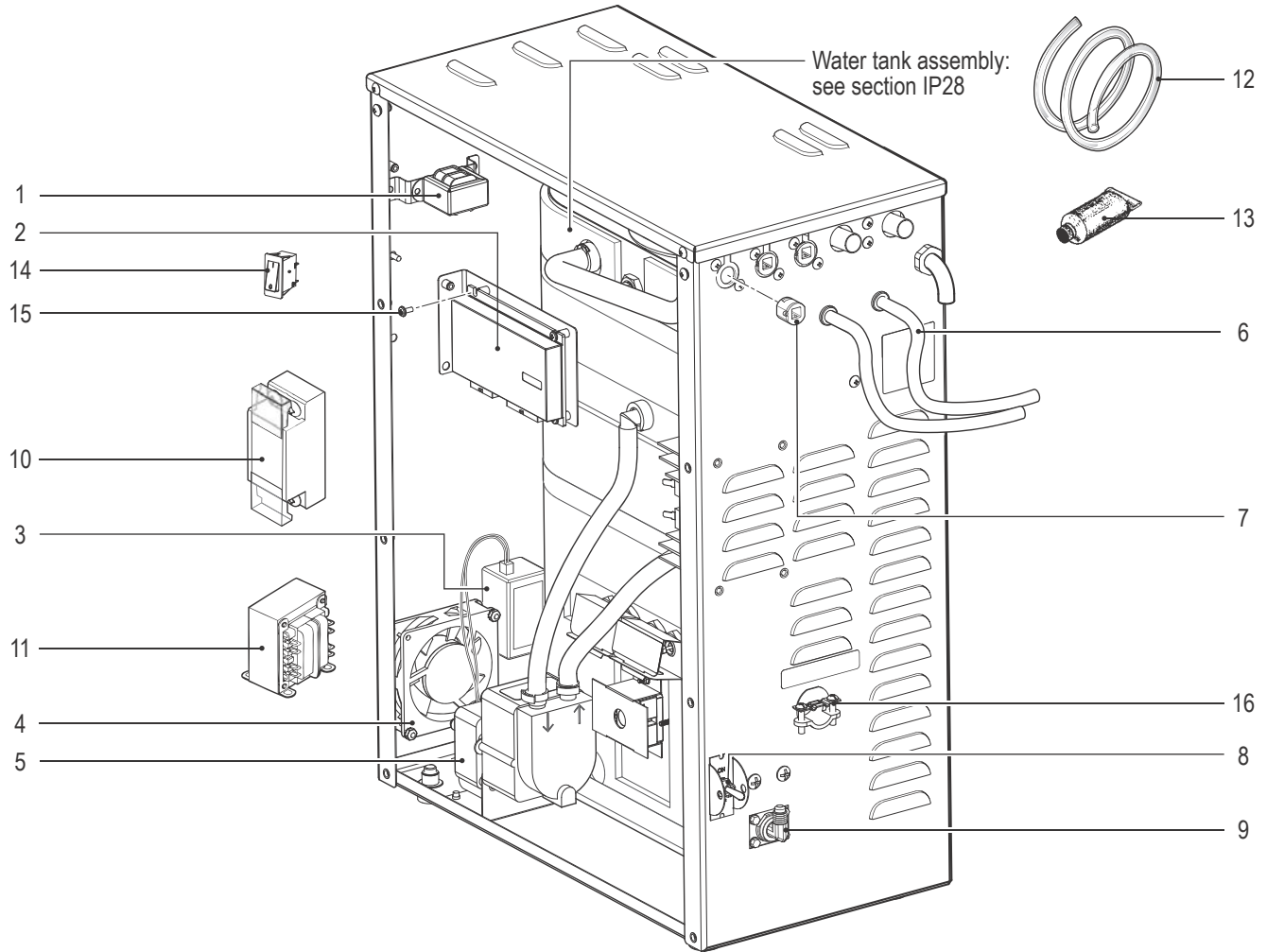

SERA2 - Main Chassis, Rear - Parts List

ITEM #	PART #	DESCRIPTION
1	WC-589-101*	TRANSFORMER,120VAC-24V 4.8A W/ LEADS & MOLEX CONNECTOR
2	WC-10001*	CONTROL MODULE, UPM 120/220V G4
3	WC-1064*	POWER SUPPLY,100-240Vac X12Vdc W/ CONNECTORS
4	WC-1066*	FAN, CHASSIS W/CONNECTORS SERAPHIM
5	WC-1040*	PUMP, WATER CENTRIFUGAL 120V 60Hz
6	WC-5307*	TUBE, 3/16 ID x 3/32W SILICONE GEN USE
7	WC-14054	BUSHING, LOCKIT STRAIN RELIEF .220-.290 OD CABLE
8	WC-103	SWITCH, TOGGLE NON-LIT DPST 25A 125/250VAC RESISTIVE

ITEM #	PART #	DESCRIPTION
9	WC-2401-P	ELBOW 3/8 NPT X 1/4 FLARE PLTD
10	WC-596K	KIT, NOISE FILTER EMI 250V/30A 1PH (EXPORT UNITS)
11	WC-592	TRANSFORMER, 230-115V 130VA SERA30 (EXPORT UNITS)
12	WC-5310*	TUBE, 5/16 ID x 1/8W SILICONE
13	WC-5231*	COMPOUND, HEAT SINK 50Z
14	WC-1512	BREAKER, CIRCUIT 2-POLE 5A/250VAC (EXPORT UNITS)
15	WC-4514	SCREW, 8-32x3/8 PAN HEAD PH SS
16	WC-1412	CORD GRIP, 1" O.D. THREAD, METAL

*Recommended parts to stock

SERA2 - Brew Head - Exploded View

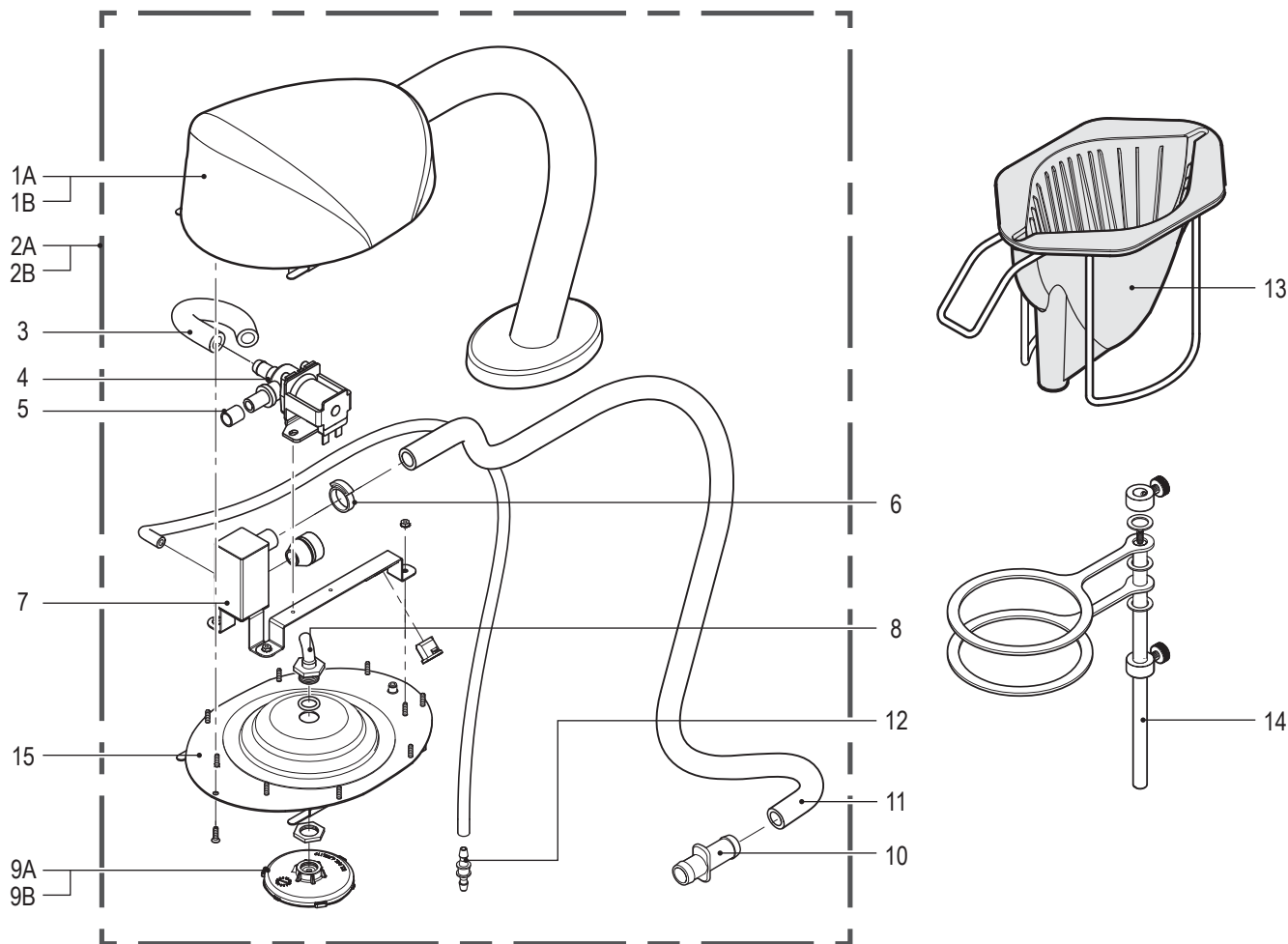

SERA2 - Brew Head - Parts List

ITEM #	PART #	DESCRIPTION
1A	WC-66099-BLK	HEAD, BREW ASSY SERAPHIM BLACK (HOUSING ONLY)
1B	WC-66099-WHT	HEAD, BREW ASSY SERAPHIM WHITE (HOUSING ONLY)
2A	SERA-BH-BLK120	BREW HEAD ASSY, BLACK 120V COMPLETE
2B	SERA-BH-WHT120	BREW HEAD ASSY, WHITE 120V COMPLETE
3	WC-5310*	TUBE, 5/16 ID x 1/8W SILICONE
4	WC-889-103*	VALVE, DUMP LEFT 120V 12W SERAPHIM
5	WC-53165	TUBE, 1/2 ID x 1/16W SILICONE DUROMETER 50A
6	WC-43813	CLAMP, HOSE SNAP-GRIP NYLON .750/.875
7	WC-66092K*	KIT, ASSY WEIR BOX & BUSHING SERAPHIM

ITEM #	PART #	DESCRIPTION
8	WC-2962K	KIT, FITTING SPRAYHEAD SS
9A	WC-29025	SPRAYHEAD, PURPLE ADVANCE FLOW
9B	WC-29065	SPRAYHEAD, GRAY ADVANCED FLOW
10	WC-2959-101	FITTING, STRAIGHT 12mm PLASTIC
11	WC-5350*	TUBE, 1/2 ID x 1/8W SILICONE GEN USE
12	WC-29105	COUPLER, 3/16" BARBED STRAIGHT SERAPHIM
13	WC-3411	BREW CONE ASSY, OPEN BREW CGC
14	WC-73141K	KIT, HOLDER BREW CONE SERA
15	WC-73131K	KIT, DOME PLATE ASSY SERAPHIM (INCLUDES ITEM 8)

*Recommended parts to stock

SERA2 - Touch Screen and Drip Tray - Exploded View

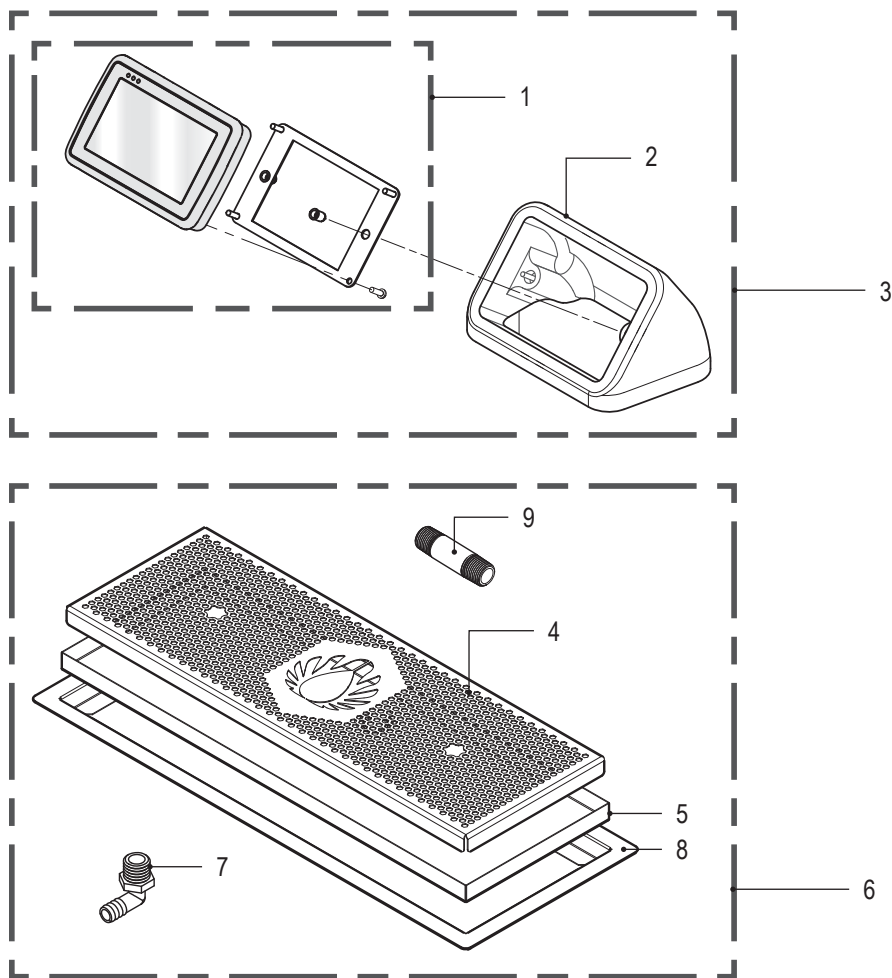

SERA2 - Touch Screen and Drip Tray - Parts List

ITEM #	PART #	DESCRIPTION
1	WC-37580*	KIT, ASSY TOUCH SCREEN & BACKING PLATE SERAPHIM
2A	WC-66095-BLK	HOLDER, UCM SERAPHIM BLACK
2B	WC-66095-WHT	HOLDER, UCM SERAPHIM WHITE
3A	SERA-UH-BLK	HOLDER, UCM BLACK SERAPHIM
3B	SERA-UH-WHT	HOLDER, UCM WHITE SERAPHIM
4	WC-65034	SCREEN, DRIP TRAY SERAPHIM

ITEM #	PART #	DESCRIPTION
4	WC-65034	SCREEN, DRIP TRAY SERAPHIM
5	WC-65035	DRIP TRAY ASSY SERAPHIM
6	WC-65041	DRIP TRAY ASSY, COMPLETE
7	WC-2461	ELBOW, 1/2 NPT MALE BARBED NYLON
8	WC-65035	DRIP TRAY ASSY SERAPHIM
9	WC-29111	FITTING, NIPPLE 1/2" NPT X 3" LG. PVC

*Recommended parts to stock

WC-62107 - Tank Assembly

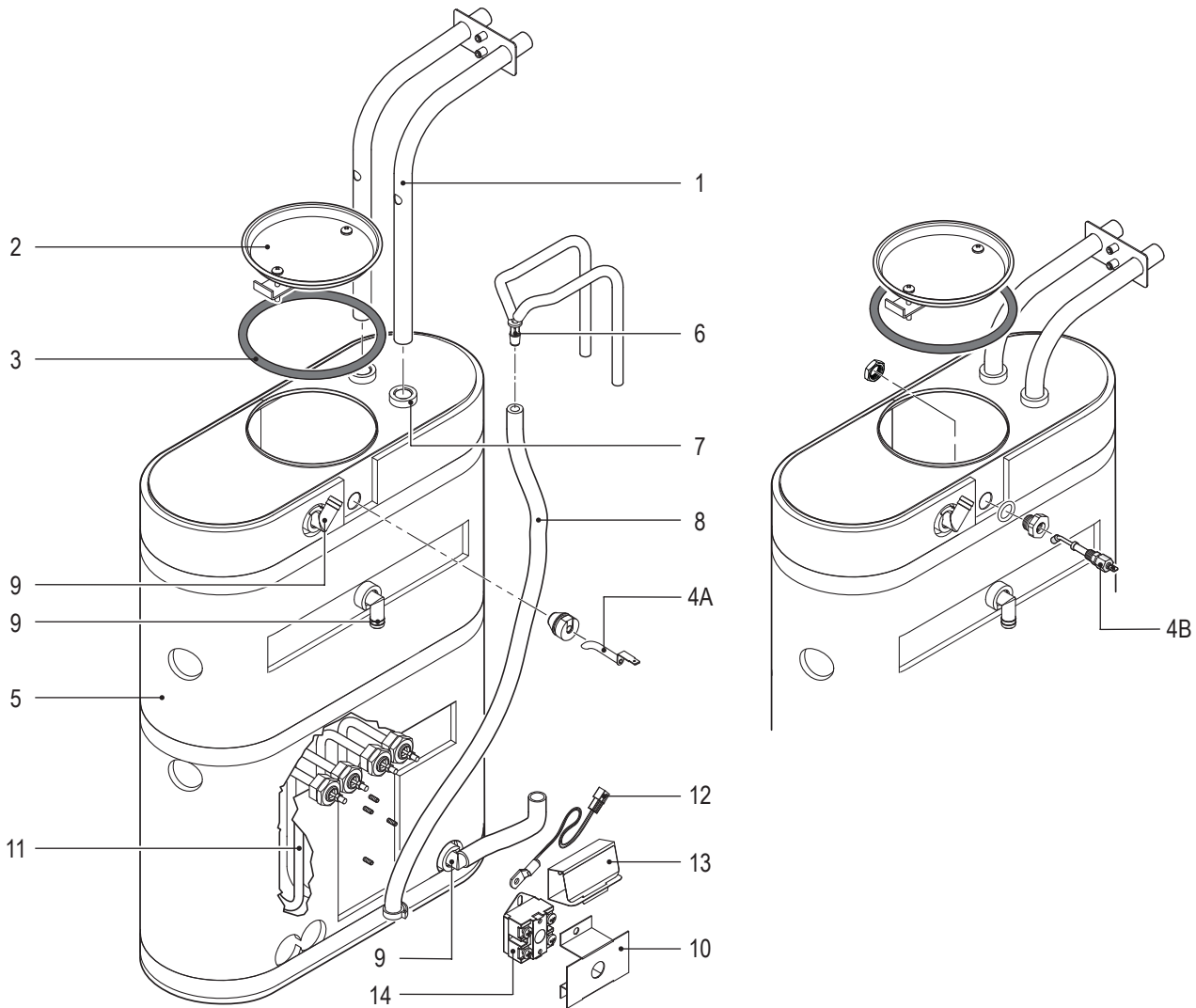

WC-62107 - Tank Assembly - Parts List

ITEM #	PART #	DESCRIPTION
1	WC-53162	TUBE, RETURN ASSEMBLY SERA
2	WC-37008	KIT, TANK LID ROUND
3	WC-43067*	O-RING, 4-1/2" I.D. X Ø.285 SILICONE TANK LID
4A ¹	WC-5528K*	KIT, WATER LEVEL PROBE, SILICONE
4B ²	WC-5502-01*	KIT, PROBE, ASSY WATER LEVEL W/HEX FITTING, O-RING & NUT
5	WC-62107	TANK, COMPLETE 5000W SERAPHIM
6	WC-2221	REDUCER, 3/16" TO 5/16" BARBED Y-CONNECTOR
7	WC-2628*	BUSHING, CONICAL.469 ID X .945 OD X .986 LG 8mm GEN USE

ITEM #	PART #	DESCRIPTION
8	WC-5310*	TUBE, 5/16 ID x 1/8 W SILICONE
9	WC-37365*	KIT, FITTING TANK INLET
10	WC-43055*	GUARD, SHOCK RESET THERMOSTAT
11	WC-934-04*	KIT, ELEMENT HEATING 2.5KW 220V W/ JAM NUT & SILICONE WASHERS
12	WC-1438-101*	SENSOR, TEMPERATURE TANK
13	WC-4394*	GUARD, SHOCK/HEATING ELEMENT FOR SINGLE HEATING ELEMENT
14	WC-522*	THERMOSTAT, HI LIMIT HEATER CONTROL DPST 277V 40A

¹ Units built 01/04/2019 and later.

² Units built before 01/04/2019. Replaces WC-5527

* Recommended parts to stock.

(UCM TOUCH SCREEN) Pin Assignments		(UPM) Pin Assignments	
8 Pin Connector		20 Pin Connector	
1	12 Vac Input (Back Light)	1	120V Hot Input
2	Vdd +5Vdc	2	120V Hot Input
3	Vss- (Logic Common)	3	Brew Valve Right
4	Not Used	4	Brew Valve Left
5	12 Vac Input (Back Light)	5	120V Neutral
6	Data Communication First	6	Inlet Valve
7	Not Used	7	Not Used
8	Not Used	8	Not Used
5 Pin Connector		6 Pin Connector	
1	TX - Transmit	1	Not Used
2	RX - Receive	2	Not Used
3	Not Used	3	Not Used
4	Vdd +5Vdc	4	Not Used
5	Vss- (Logic Common)	5	Not Used
(USB) Pin Assignments		14 Pin Connector	
6-Pin Connector		1	12 Vac Input
1	Vss- (Logic Common)	2	12 Vac Input
2	TX - Transmit	3	Tank Water Level Probe
3	Vdd +5Vdc	4	Vdd +5Vdc
4	RX - Receive	5	Not Used
5	Not Used	6	Tank Temperature Sensor
6	Not Used	7	Tank Temperature Sensor
7	Not Used	8	(Not Used)
8	Not Used	9	Data Communication Next
9	Not Used	10	Vss- (Logic Common)
10	Not Used	11	Solid State Relay +5Vdc
11	Not Used	12	Data Communication First
12	Not Used	13	Solid State Relay - Common
13	Not Used	14	UPM Ground

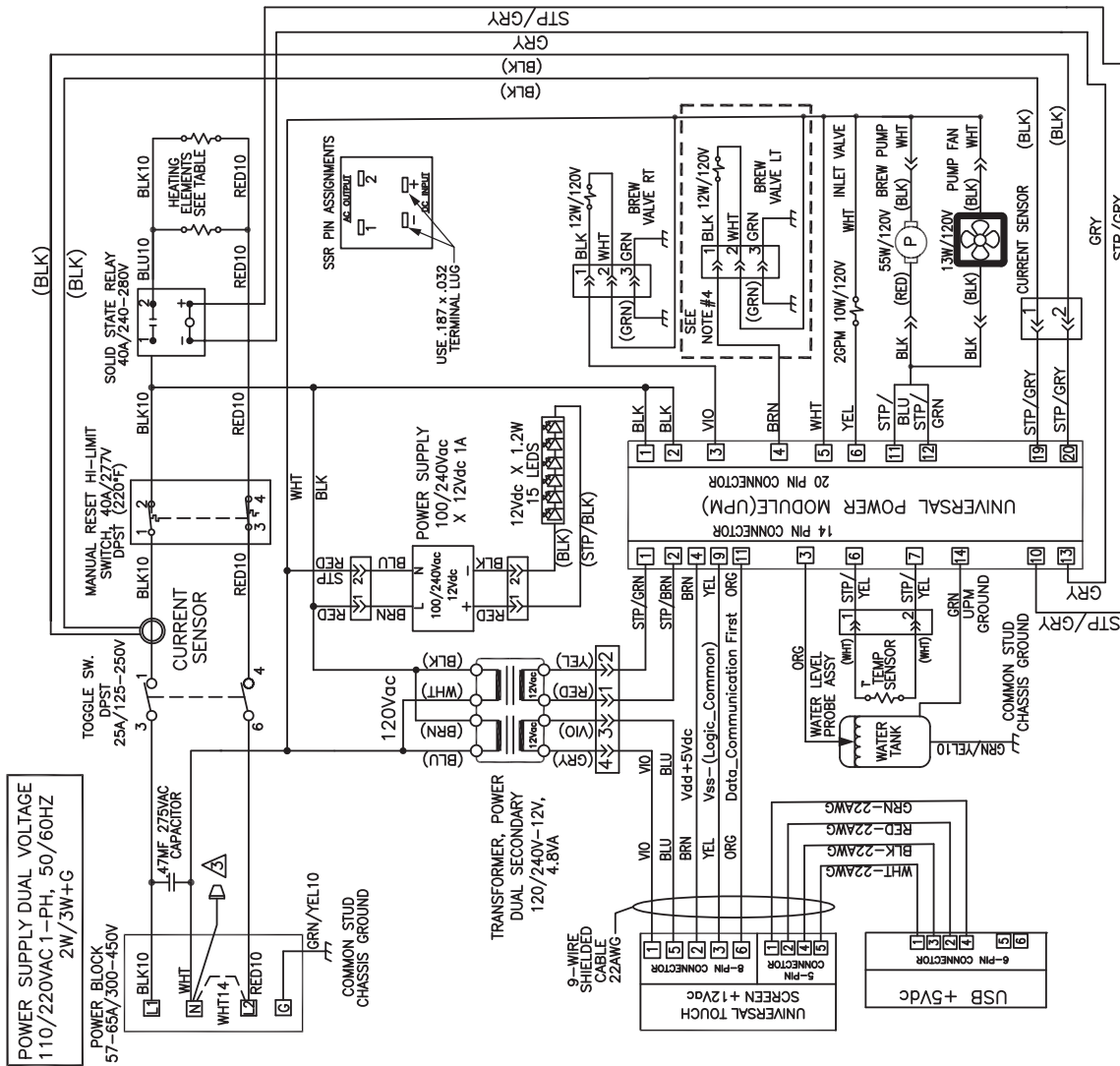

ELECTRICAL RATING TABLE						
Model	Voltage V	Amps A	Watts W	Hertz Hz	# of Conductor Wires	Phase
SERAX	120	12.5	1500	50/60	(2)	1
	110/240	22.7	5000		(2)	1
	120	12.5	1500		(2)	1
	120/240	22.5	5000		(2)	1

ELECTRICAL RATING TABLE			
Model	Voltage V	Amps A	Watts W
SERAX	120	12.5	1500
	110/240	22.7	5000
	120	12.5	1500
	120/240	22.5	5000

ELECTRICAL RATING TABLE			
Model	Voltage V	Amps A	Watts W
SERAX	120	12.5	1500
	110/240	22.7	5000
	120	12.5	1500
	120/240	22.5	5000

4. VALVE NOT USED ON MODEL SERA1.
 5. FOR USE WITH 220V (FACTORY DEFAULT); JUMPER TO BE DISCONNECTED AND CAPPED.
 6. FOR USE WITH 120V; REMOVE CAP FROM JUMPER & CONNECT TO POINT L2 ON TERMINAL BLOCK.
 7. USE THIS DIAGRAM FOR ALL OTHER MODELS WITH ADDED PREFIX LETTERS AND/OR SUFFIX NUMBERS ON THEIR PART NUMBERS HAVING THE SAME ELECTRICAL RATINGS.
 1. ALL WIRES SHALL BE MIN 18AWG PVC/JUL1015 UNLESS NOTED.
 NOTES: UNLESS OTHERWISE SPECIFIED

VALUE SEE TABLE	TITLE:	LADDER DIAGRAM	REVISION: B
WIRES SEE TABLE	PART NUMBER:		
AVERAGE SEE TABLE	LD-SERA		
WIRES 20/28AWG	PHASE 1PH		

(UCM TOUCH SCREEN) Pin Assignments		(UPM) Pin Assignments	
8 Pin Connector		20 Pin Connector	
1	12V Vac Input (Back Light)	1	120V Hot Input
2	VDD +5Vdc	2	120V Hot Input
3	VSS- (Logic, Common)	3	Brew Valve Right
4	Not Used	4	Brew Valve Left
5	120V Neutral	5	Inlet Valve
6	12V Vac Input (Back Light)	6	Not Used
7	Data_ Communication First	7	Not Used
8	Not Used	8	Not Used
5 Pin Connector		14 Pin Connector	
1	TX - Transmit	1	12 Vac Input
2	RX - Receive	2	12 Vac Input
3	Not Used	3	Tank Water Level Probe
4	VDD +5Vdc	4	Vdd +5Vdc
5	VSS- (Logic, Common)	5	Not Used
6-Pin Assignments (USB)		6-Pin Assignments	
1	VSS- (Logic, Common)	1	Not Used
2	TX - Transmit	2	Not Used
3	VDD +5Vdc	3	Current Sensor
4	RX - Receive	4	Current Sensor
5	Not Used	5	Not Used
6	Not Used	6	Not Used

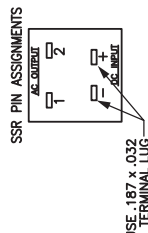

ELECTRICAL RATING TABLE

Model	Voltage V	Amps A	Watts W	Hertz Hz	# of Conductor Wires	Phase	# of Tank Elements	Tank Element Rating W/V
SERA30x	220	22.7	5000	50/60	2	1	2	2500W/220V
SERA31x (Domestic)	240	22.5	5400	50/60	2	1	2	2500W/220V

LADDER DIAGRAM

TITLE:	LD-SERA-30	REVISION:	B
PART NUMBER:	LD-SERA-30		

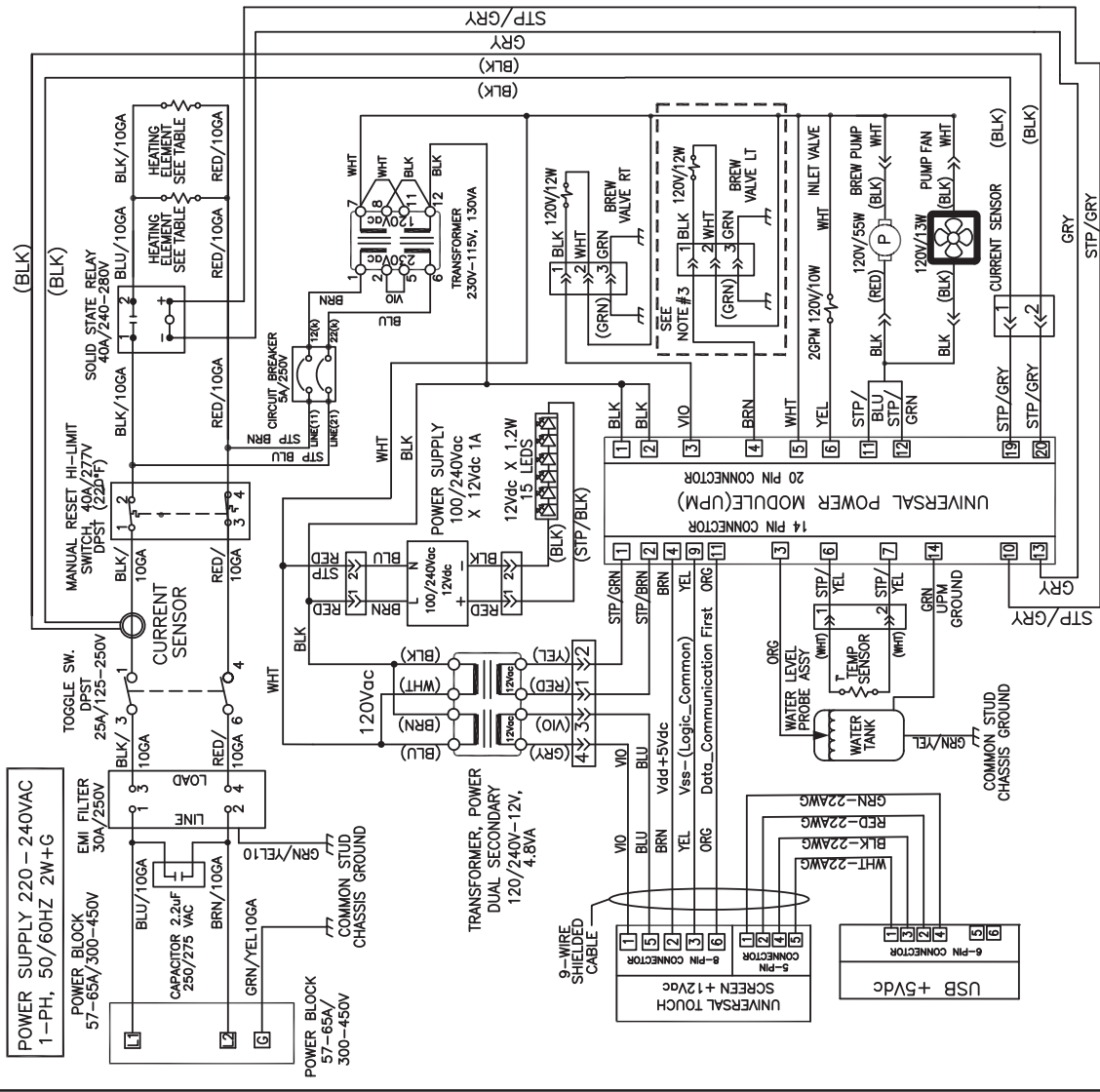

3. VALVE NOT USED ON MODEL SERA1.
2. USE THIS DIAGRAM FOR ALL OTHER MODELS WITH ADDED PREFIX LETTERS AND/OR SUFFIX NUMBERS ON THEIR PART NUMBERS HAVING THE SAME ELECTRICAL RATINGS.
1. ALL WIRES SHALL BE MIN 18AWG PVC/JUL1015 UNLESS NOTED. NOTES: UNLESS OTHERWISE SPECIFIED

**WARNING:**

Electric Shock Hazard - the following procedures are to be performed only by a qualified service technician. Disconnect power when replacing components. Lock out and tag the circuit breaker. Neither Wilbur Curtis Co., Inc. nor the seller can be held responsible for the interpretation of this information, or any liability in connection with its use.

Scald and Burn Hazard - keep body parts clear of hot surfaces during troubleshooting.



IMPORTANT: If it is necessary to replace the G4 universal power module (UPM), always check all inlet and dump (brew) valve coils for a short and replace as necessary, before replacing the module. See the **Valve Test Procedure**, below to test for defective valves.

Troubleshooting Guidelines

- If an error message appears on the display, consult the ERROR CODES section before troubleshooting.
- A brewer that is not level may not function properly. Make sure the brewer is properly leveled before proceeding.
- This troubleshooting guide identifies some, but not all, possible causes for common problems that can occur.
- Use this troubleshooting guide along with the appropriate ELECTRICAL SCHEMATIC.

Valve Test Procedure

Use a digital multi-meter to measure the resistance of valve coils.

Measure the resistance across the valve coil terminals with the wiring harness disconnected. Reverse the meter leads on the terminals and measure the resistance in the opposite direction. A resistance of less than 100 ohms, in either direction, indicates a shorted coil. The valve must be replaced.

If a shorted coil is not detected, test for an open coil:

- 1 Reconnect the valve terminals to the wiring harness.
- 2 Power up the brewer and test the valve using the diagnostics in section TG11.

Water Not Hot Enough

- 1 If the water heats, but is not hot enough, first check for the correct temperature setting on the control panel. Reprogram as necessary.
- 2 If the temperature setting is OK, and the actual water temperature does not match setting on the control panel, replace the temperature sensor.

Water Heats More Slowly Than Usual

- 1 Check for power across the terminals of the heating element(s). If power is being supplied, disconnect the heating element(s) and check for continuity. Replace a heating element if the resistance is too high (nominal resistance is 13 Ohms).
- 2 If there is no power to the heating element(s), check the wiring to any element that does not have the proper voltage across it. Also check for corroded connections anywhere between the power cord and the heating element(s).

Dispenser Overflows During Brewing

- 1 Check to make sure the universal control module (UCM) brew, bypass* and dilution* levels are set properly.
- 2 Check for a missing spray head. Replace as needed.
- 3 Make sure the dispenser is empty before starting the brew cycle. If not, empty it before brewing.

*Some units do not have this function, see the ELECTRICAL SCHEMATIC.

No Power - Display Not Lit

- 1 Make sure the circuit breaker to the circuit supplying power to the brewer is not tripped and is turned on.
- 2 On brewers with a power plug, make sure it is connected to the power receptacle.
- 3 Make sure that the main power toggle switch on the back panel is turned ON.
- 4 Verify that all wires from the power cord are properly connected inside the unit. Check to make sure the wires are not burned/overheated. Check chassis ground.
- 5 Check the low voltage input to the universal control module (UCM) from the transformer (see the ELECTRICAL SCHEMATIC). If there is power into the UCM, but the display is blank, the UCM is probably bad.
- 6 If there is no power into the UCM, trace the circuit back (using the wiring diagram) to the power cord to find out where power is lost. If there is power into the thermostat reset switch, but not out, see step 7.
- 7 If there is power into the thermostat reset switch, but not out, check to make sure that the water tank is not empty. If the tank is empty, the reset switch has probably opened up due to a low water level, go to **Water Tank Does Not Fill**. If there is water in the tank, but no power out, push in on the reset switch button to see if it restores power. If power is restored, check to make sure that the switch is not opening up at the wrong temperature (the switch should not open up at normal water temperatures). If there is still no power through the switch after pushing the button, replace the thermostat reset switch.

Brewer Does Not Start When Brew Button is Pressed

- 1 If **Brewing** appears on the display, check for faulty wiring and connections between the universal power module (UPM) and the valves.
- 2 If **Brewing** does not appear on the display, check for a faulty universal control module (UCM) or universal power module (UPM).

Sensor Error Message

This error indicates a malfunction (open circuit) in the temperature sensor system. Once the malfunction is corrected, the error message must be cleared. To reset the brewer and return to normal operation, turn the toggle switch on the back of the brewer to the OFF position for 5 seconds, then back ON.

- 1 Check for and open circuit across the leads of the temperature sensor while it is disconnected from the universal control module (UCM). If an open circuit is measured, replace the sensor.
- 2 If the sensor resistance is less than 200 kOhm check the sensor wires for corrosion and reconnect them to the UPM. Afterward, if the error message comes back after resetting the control and power modules, replace the UPM.

Water Tank Overfills

- 1 Turn the toggle switch on the back of the brewer ON and OFF. If water continues to flow when the switch is in both positions, replace the inlet valve.
- 2 If water stop flowing to the water tank when the toggle switch is turned OFF and continues when the switch is turned back ON, remove the orange wire from the water probe on the tank. While power is ON, short the end of the orange wire to the metal surface on the outside of the tank. If water does not stop flowing when the orange wire is shorted to the tank, check the tank ground connection and the continuity of the orange wire connecting to the universal power module (UPM). If both are OK, replace the UPM.

Water Tank Does Not Fill



IMPORTANT: No water or low water in the tank can cause the tank to overheat, resulting in the thermostat reset switch opening. If after correcting a tank fill problem there is no power to the control panel, wait for the water tank to cool and push the reset switch button to reset.

- 1 Check to make sure the water supply is turned on. Check for a plugged water supply line, water filter or inlet valve.
- 2 If there are no plugs in the water supply line, check for power across the inlet valve terminals. If power is being supplied, but there is no water flow, replace the inlet valve.
- 3 If power is not being supplied to the inlet valve, check the wires between the universal power module (UPM) and the inlet valve. Check for corroded connections.
- 4 If the wiring between the UPM and the inlet valve is OK, but there is no power to the inlet valve, remove the orange wire from the water tank probe. If the water tank starts to fill, check the water probe to see if it is shorted. If the water tank does not start to fill, replace the UPM.

Coffee Too Strong

See *Dispenser Not Filled To Normal Level During Brewing*.

Dispenser Not Filled To Normal Level During Brewing

- 1 Check to make sure that the universal control module (UCM) brew, bypass* and dilution* levels are set properly.
- 2 Check to make sure that the flow rate and water pressure from the water supply line meet the minimum specifications for the brewer. See the SPECIFICATIONS section.
- 3 Check to make sure that the spray head is clean and free of debris. Clean or replace as needed. Also make sure that the spray head is correctly aligned and that the tubing is routed properly to allow for maximum water flow (no kinks).
- 4 Remove the brew basket and place a large container under the dump (brew) and dilution outlet points. Run a brew cycle and confirm that the brew pump is pumping water during the brew cycle. If the pump is working, check to make sure that the dump (brew) valve opens during the brew cycle. If flow is restricted or non-existent, check for obstructions in the related tubing or the brew valve. If there are no obstructions, but flow through one particular valve is slow, it can be assumed that the particular valve is not opening all the way and should be replaced. If water does not flow at all through the brew valve, or the brew pump is not working during the brew cycle, check to make sure that power is being supplied to the valve or pump. If power is not being supplied to the valve or pump, check the wiring and the universal power module (UPM). If the wiring is OK, replace the UPM.

*Some units do not have this function, see the ELECTRICAL SCHEMATIC.

Dispenser Overflows All Of The Time

- 1 Check to see if water continues to flow from the spray head when the toggle switch is turned OFF. Replace the brew valve if it is stuck open.
- 2 If one or more of the brew valves mentioned in step 1 turns on when the toggle switch on the back is ON and turns off when the switch is OFF, replace the universal power module (UPM).

No Water Flows From Brewer During Brewing

- 1 Make sure that the water supply is turned on.
- 2 Check to see if the water in the tank is level with the water tank probe? If not, see *Water Tank Does Not Fill*.
- 3 If the water tank is full, the water is hot and power is on, but NO water flows during a brew cycle, the problem is usually a bad universal power module (UPM). Run a brew cycle and check for power from the UPM to the dump (brew), bypass* and dilution* valves. If there is no power output, replace the UPM.
*Some units do not have this function, see the ELECTRICAL SCHEMATIC.

Low Water Flow Warning

See *Water Level Error Message*.

Water Level Error Message

Water level fill error or overflow. This error message occurs when the inlet valve solenoid has been on too long during initial fill or tank refill, See the ERROR CODES section for the maximum times allowed. Once the malfunction is corrected, the error message must be cleared. To reset the unit and return to normal operation, turn the toggle switch on the back of the brewer to the OFF position for 5 seconds, then back ON.

- 1 Make sure that the water supply valve is completely open and that the water filter is not plugged.
- 2 Check to make sure that the flow rate from the water supply line meets the minimum flow rate specifications for the brewer. Also check the water pressure. See the SPECIFICATIONS section.
- 3 Check for blockage at the inlet valve inlet or outlet. Check for blockage in the tubing between the inlet valve and the water tank.
- 4 Check the water probe wire for an open condition or corroded connections.
- 5 If the probe connections are OK, cycle power to the unit by turning the rear toggle switch OFF, then ON. Check to see if power is applied to the inlet valve terminals. If power is applied to the terminals, but there is not water flow, replace the inlet valve.
- 6 Check for power from the universal power module (UPM) to the inlet valve. If the wiring is OK, replace the UPM.

“Internal Error 1” Message on Display

Check the wiring harness that connects from pins 4, 9 and 11 of the 14-pin connector on the universal power module (UPM) to pins 2, 3 and 6 of the 8-pin connector on the universal control module (UCM).

“Internal Error 2” Message on Display

The universal power module (UPM) and universal control module (UCM) have a mismatch in their settings. A firmware update is needed. See *PROGRAMMING GUIDE*.

Water Does Not Heat At All

- Check to see if the water level in the tank is in contact with the water level probe. If not, see *Tank Does Not Fill*. The water will not heat unless it is in contact with the probe.
- If the water heats, but is not hot enough, see *Water Not Hot Enough*.
- If **Ready to brew** appears on the display, but the water is not hot, check the resistance across the leads of the temperature sensor. If the resistance is less than 10 k and the water is not hot, replace the temperature sensor. If the sensor resistance is above 10 k when the water is cool, replace the universal power module (UPM).

If **Heating...** appears on the display, but the water is not hot, follow the steps below. The following steps are performed with the rear toggle switch in the ON position.

- 1 Check for power across the terminals of the heating element(s). If power is being supplied, remove the wires and check for an open heating element.
- 2 If there is no power to the element(s), trace the circuit back (using the ELECTRICAL SCHEMATIC) to the power cord to find out where power is lost. If there is power into the solid state relay(s) (SSRs) but not out, see the following step. On units having two SSRs, be sure to check both.
- 3 If there is power into a SSR, but not out, check for 5 Vdc (nominal*) across the + and - pins of the SSR(s). If there is 5 Vdc across the + and - pins of the SSR(s), but no (or low) output voltage at a SSR output terminal, replace the SSR. If 5 Vdc is not being supplied from the UPM, but **Heating...** appears on the display, check the wiring from the UPM to the SSR(s). If the wiring is OK, replace the UPM.

Water Too Hot (Boiling or Excessive Steaming)



IMPORTANT: Before proceeding, make sure that the control panel temperature is adjusted to compensate for higher elevations. The factory setting is 200°F. Reduce the temperature setting two degrees for every 1000 feet of elevation above 4000 feet.

- 1 If **Over Temp Sensor** or **Ready to Brew** appears on the display and the water is too hot, go to *Over Temp Sensor Error Message*.
- 2 If the display reads **Heating** constantly, first check to make sure that the temperature sensor is attached tightly to the tank and that heat sink compound was used. A properly mounted sensor should have a resistance of around 7 k when the water is hot. If not, replace the sensor.
- 3 Check to see if the universal power module (UPM) constantly has +5 Vdc (nominal) output to the solid state relay (SSR), regardless of the resistance of the temperature sensor. If so, the UPM is probably bad.
- 4 If the UPM is working properly, check for a shorted SSR.

Over Temp Sensor Error Message

This error message indicates that the universal control module (UCM) has detected a water overheating problem. The universal power module (UPM) is reading a water temperature in the tank above 210°F. If the water temperature is too hot, but **Heating...** appears on the display, see *Water Too Hot*. Once the malfunction causing the error is corrected, the error message must be cleared. To reset the brewer and return to normal operation, turn the toggle switch on the back of the brewer to the OFF position for 5 seconds, then back on.

- 1 Check for 5 Vdc (nominal) across the + and - pins of the solid state relay (SSRs). If no power is applied to the SSR and the heating elements are always on, replace the SSR. On units having two SSRs, check both.
- 2 Turn off power to the brewer and allow the water tank to cool. Once cool, turn power back on while monitoring the voltage across the + and - pins of the SSR(s). During normal operation, the voltage should be 5 Vdc, until the water is hot, then drop to below 1 Vdc. The universal power module (UPM) should be replaced if the voltage reads 5 Vdc constantly even though **Ready to brew** or **Over Temp Sensor** appears on the display.
- 3 If the UPM is operating normally, check for a false over-temp error caused by the temperature sensor. Check the resistance across the leads of the temperature sensor. If the resistance is less than 10 k when the water is cool, replace the temperature sensor.

Overview

The G4 control module diagnostics can be used to detect electrical circuit failures in the brewer. When a circuit failure is identified, the individual components and wiring in the circuit must be checked to determine the exact cause of the failure using the ELECTRICAL SCHEMATIC. If a failure is not detected using the diagnostics, troubleshoot the problem according to the symptoms listed in other sections of this TROUBLESHOOTING GUIDE.

The diagnostics can also be used to help diagnose certain mechanical failures. See the following steps.

Using the Diagnostics

- 1 Enter programming mode by tapping the (white) Curtis logo on the touchscreen five (5) times.
- 2 Enter the access code, then press **OK** (the default code is 1 2 3 4).
- 3 The **MAIN MENU** screen will appear. Press **Control Settings**.
- 4 Press **Diagnostics**. When prompted, place an empty container under the brew basket, then press **OK**.
- 5 Press a button to test the desired circuit or **Auto Test** to test all circuits. If a button is highlighted green the circuit has passed the (electrical) test. If the button is highlighted red, the circuit has failed the test.

If the circuit tested fails, check to make sure that power is being supplied to the component during normal operation. If power is supplied, and it does not operate, replace the component. If power is not being supplied, check the wiring and the UPM.

If a valve circuit passes the test, check for a mechanical failure by listening for the valve to “click” when the test button is pressed. To check for a failed pump run a brew cycle and check for fluid flow through the pump.



Curtis logo

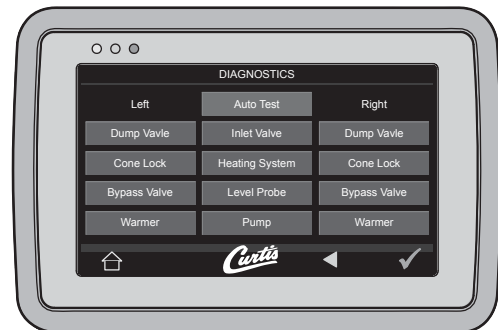

Diagnostics Screen

Button layout varies based model

Warning Messages - Allows Brewer to Continue Brewing

MESSAGE DISPLAY	WARNING DESCRIPTION	CAUSE
Maintenance Required	Maintenance Required	Brew count "Gallons Since Reset" exceeds programmed preventative maintenance period.
Low Water Flow Warning	Low Water Flow	If the Inlet valve remains on longer than XX seconds (during the brew cycle only) and repeats TWICE during that brew cycle. It shall clear upon the next brew and if the same low flow exists again, it will re-appear. XX = Alpha 20 secs; Gem/TP Twin 40 secs; Gem/TP Single 30 secs.
Internal Error 2	UPM-UCM have a mismatch in their settings.	UPM-UCM have a mismatch in their settings, firmware update needed.

Error Messages - Brewer Will Stop Brewing

MESSAGE DISPLAY	ERROR DESCRIPTION	CAUSE
Water Level Error	Fill run error/Overflow	The water inlet valve has either been open for more than 10 minutes on the initial tank fill or has been open for 120 seconds on large brewers and 30 seconds on CGC, tea brewers in normal operation.
Sensor Error	Open Sensor	Break in the temperature thermistor circuit or short circuit.
Over Temp. Error*	Excess Temperature	The sensor is reading that temperature in the heating tank has risen above 210°F, or sensor has shorted to ground.
Internal Error 1	UPM-UCM Communication	Break in the UPM-UCM communication circuit.

* This error is disabled on CGC and Seraphim® models.

Configuration Error Message - Brewer Will Not Function Properly

MESSAGE DISPLAY	ERROR DESCRIPTION	CAUSE
Configuration Error	UPM software revision does not support the model selected.	The universal power module (UPM) has an old software version and is not compatible with the brewer model in which it has been installed.

Wilbur Curtis Co., Inc. certifies that its products are free from defects in material and workmanship under normal use. The following limited warranties and conditions apply:

- 3 years, parts and labor, from original date of purchase on digital control boards
- 2 years, parts, from original date of purchase on all other electrical components, fittings and tubing
- 1 year, labor, from original date of purchase on all other electrical components, fittings and tubing

Additionally, Wilbur Curtis Co., Inc. warrants its grinding burrs for forty (40) months from the date of purchase or 40,000 pounds of coffee, whichever comes first. Stainless steel components are warranted for two (2) years from the date of purchase against leaking or pitting. Replacement parts are warranted for ninety (90) days from the date of purchase or for the remainder of the limited warranty period of the equipment in which the component is installed.

All in-warranty service calls must have prior authorization. For authorization, call the Technical Support Department at 800-995-0417. Additional conditions may apply. Go to www.wilburcurtis.com to view the full product warranty information.

CONDITIONS & EXCEPTIONS

The warranty covers original equipment at time of purchase only. Wilbur Curtis Co., Inc., assumes no responsibility for substitute replacement parts installed on Curtis equipment that have not been purchased from Wilbur Curtis Co., Inc. Wilbur Curtis Co., Inc. will not accept any responsibility if the following conditions are not met. The warranty does not cover:

- **Adjustments and cleaning:** *The resetting of safety thermostats and circuit breakers, programming and temperature adjustments are the responsibility of the equipment owner. The owner is responsible for proper cleaning and regular maintenance of this equipment.*
- **Replacement of items subject to normal use and wear:** *This shall include, but is not limited to, spray heads, faucets, light bulbs, shear disks, "O" rings, gaskets, silicone tubing, silicone elbows, canister assemblies, whipper chambers and plates, mixing bowls, agitation assemblies and whipper propellers.*

The warranty is void under the following circumstances:

- **Improper operation of equipment:** *The equipment must be used for its designed and intended purpose and function.*
- **Improper installation of equipment:** *This equipment must be installed by a professional technician and must comply with all local electrical, mechanical and plumbing codes.*
- **Improper voltage:** *Equipment must be installed at the voltage stated on the serial plate supplied with this equipment.*
- **Improper water supply:** *This includes, but is not limited to, excessive or low water pressure and inadequate or fluctuating water flow rate.*
- **Damaged in transit:** *Equipment damaged in transit is the responsibility of the freight company and a claim should be made with the carrier.*
- **Abuse or neglect (including failure to periodically clean or remove lime accumulations):** *The manufacturer is not responsible for variation in equipment operation due to excessive lime or local water conditions. The equipment must be maintained according to the manufacturer's recommendations.*

Repairs and/or Replacements are subject to Curtis' decision that the workmanship or parts were faulty and the defects showed up under normal use. All labor shall be performed during regular working hours. Overtime charges are the responsibility of the owner. Charges incurred by delays, waiting time, or operating restrictions that hinder the service technician's ability to perform service is the responsibility of the owner of the equipment. This includes institutional and correctional facilities. Wilbur Curtis Co., Inc. will allow up to 100 miles, round trip, per in-warranty service call.

Return Merchandise Authorization (RMA): All claims under this warranty must be submitted to the Wilbur Curtis Technical Support Department prior to performing any repair work or return of this equipment to the factory. **All returned equipment must be properly re-packaged in the original carton and received by Curtis within 45 days following the issuance of a RMA.** No units will be accepted if they are damaged in transit due to improper packaging. **NO UNITS OR PARTS WILL BE ACCEPTED WITHOUT A RETURN MERCHANDISE AUTHORIZATION (RMA). THE RMA NUMBER MUST BE MARKED ON THE CARTON OR SHIPPING LABEL. All warranty claims must be submitted within 60 days of service. Invoices will not be processed or accepted without a RMA number. Any defective parts must be returned in order for warranty invoices to be processed and approved.** All in-warranty service calls must be performed by an authorized service agent. Call the Wilbur Curtis Technical Support Department to find an agent near you.