

Preparing your nappies:

Before their first use, nappy inserts need to be washed. After the first wash, the nappy inserts will become smaller, thicker, softer and more absorbent.

- We recommend washing three times before the first use
- Water temperature of around 40°C
- Use a perfume-free washing detergent and no fabric softener
- It is not necessary to dry the inserts between the initial washes

Note: It is not necessary to pre-wash the Snug Wrap Nappy Covers.

Washing and drying instructions:

Before washing, close the tabs on the nappy covers using the laundry tabs. If necessary, rinse cotton inserts with cold water. Machine wash the nappy inserts and covers at 60°C using $\frac{1}{4}$ of the manufacturer's recommended amount of detergent and 1 dessertspoon of Nappy Fresh.

- Use a chemical-free detergent
- Do not use fabric softener
- Do not use chlorine bleach
- Hang to dry, or tumble dry
- Do not iron
- Do not dry clean



Please see our website for recommended brands of detergents.

You do not need to soak the nappy inserts. However, if you choose to soak the inserts, we recommend using Nappy Fresh. Follow directions on the package. Do not soak the nappy covers.

real nappies™
cloth nappies • pure and simple



Contact details:

If you are still having problems or you have any questions, please contact us on:



Toll Free: 1800 531 858



Email: info@realnappies.com.au

www.realnappies.com.au

Real Nappies Pty Ltd
ABN 16 630 166 451

real nappies™
cloth nappies • pure and simple



Helpful
User
Guide

Folding the nappy insert:

Liquid Poo Fold

Often used at newborn stage, especially if breastfed.

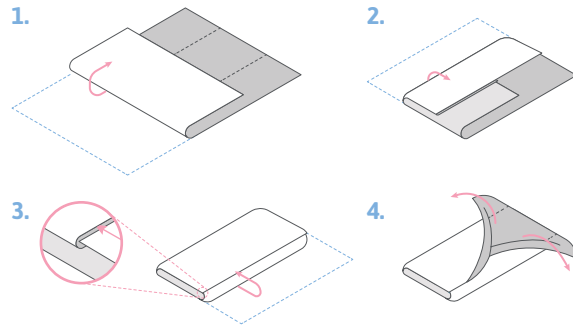

Boy Fold

For absorbency in the front. Tuck one side under to keep fold in place.

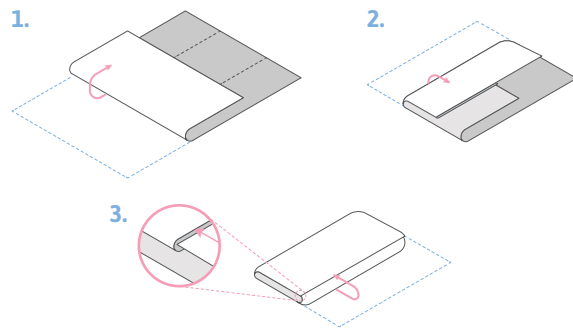

Girl Fold

For absorbency in the middle.

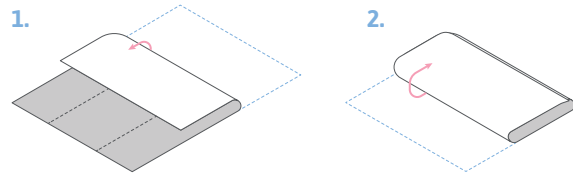

Assembling the nappy:



Putting the nappy on:

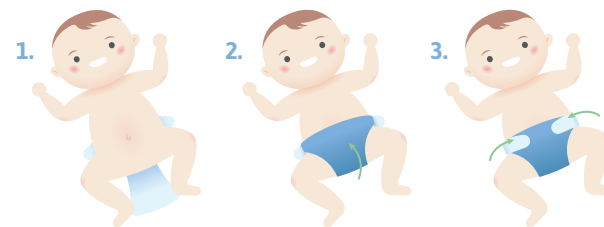





Helpful hints:

- Nappies should be changed every 2-4 hours.
- It is easiest to store used nappies in a bucket or bin with a lid.
- Do not soak nappy covers.
- Assemble the clean nappy before removing the soiled nappy from the baby for a quick and easy change.
- Always ensure nappy insert and liner are completely tucked inside the nappy cover at the waist and legs.
- Do not tuck the nappy inserts into the flaps of the cover at the front or back. This can cause leakage.
- Do not fold the liners – if you want a smaller size, cut in half.
- If using barrier cream, always use a liner.
- After washing and drying, fold all the nappy inserts ready to use.



Nappy sizes:

 newborn	 infant	 crawler	 toddler
2.5–6 kg (5–13 lbs)	5–9 kg (11–19 lbs)	8–14 kg (17–30 lbs)	13–18+ kg (28–40+ lbs)

Using the correct size nappy is essential to ensure a comfortable, leak proof fit.

Real Nappies come in four sizes to fit your baby from birth to potty training. All babies vary in shape and size, therefore, these sizes act only as a guide.

Use this brochure as a poster for quick reference.

