

circuitcubes

S T E M
S T A R T E R
K I T

WELCOME!

Circuit Cubes are electronic building blocks that add power, motion, and light to LEGOs, household items, old toys, and original projects. Designed by teachers, Circuit Cubes can turn a light on, power a motor, or make wheels spin. The only limit is your imagination!

1

Getting Started

Motors can drive cars and trucks and bikes, but they can also move bridges, open gates, help airplanes get off the ground, and do lots of other things! LEDs are super-bright lights used in flashlights, stop lights, screens, and more. They can make anything bright. Batteries are the power that make everything go and go.

In this booklet, you'll find 10 fun projects to help you explore the Motor, LED, and Battery Circuit Cubes, from your first basic flashlight to a crazy Scribblebot. You'll turn things on with the Battery Cube, make them move with the Motor Cube, and light the whole thing up with the LED Cube. They work together and separately, and the only limit is your imagination.

Once you've figured out all that Circuit Cubes can do, discover what you can do with Circuit Cubes!



2

MEET THE CUBES!

These three Circuit Cubes are all you need for endless projects and hours of fun!

Battery Cube

Perfect for LEGO®s, the rechargeable Battery Cube powers projects for up to an hour of active play time. If it's green, it's charged and ready to go; if it needs charging, plug it into a MicroUSB charger until the green light appears.



Motor Cube

A perfect fit for LEGO® gears and wheels, the Motor Cube can race in all directions! What can you create that doesn't look like a car but moves? The Motor Cube is the one to use.



LED Cube

Snap this ultra-bright oversized LED onto LEGO® bricks and get thousands of hours of light to illuminate your builds, from easy flashlight set-ups to tricky projects.



PARTS

Your STEM Starter Kit
Contains These Parts:

+6 MYLAR DISCS
(NOT PICTURED)

5

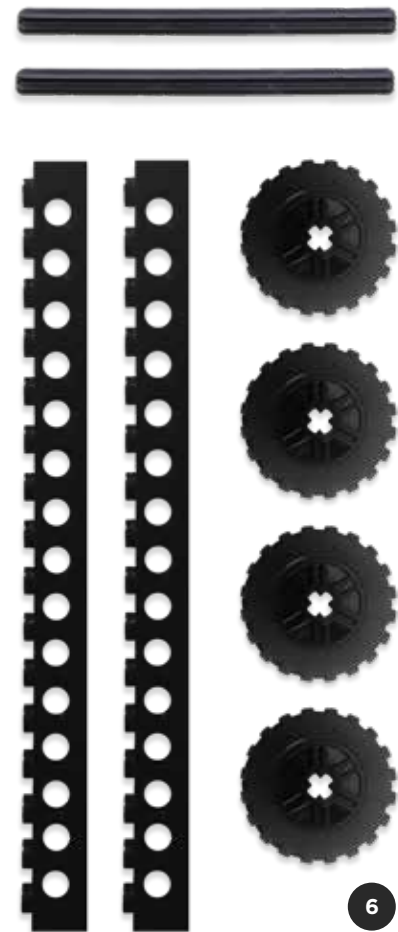
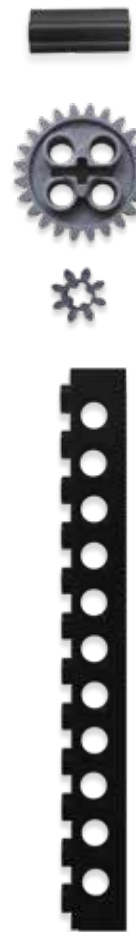
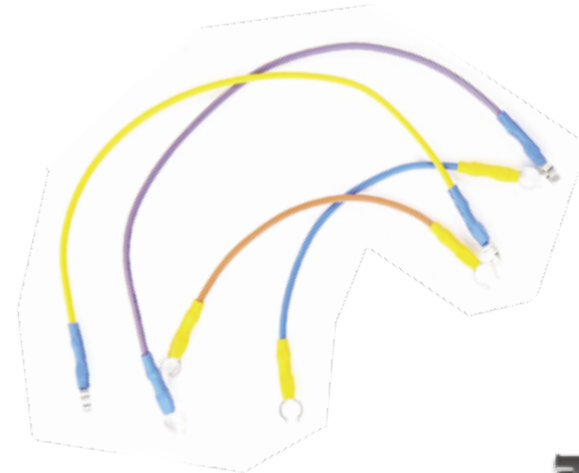
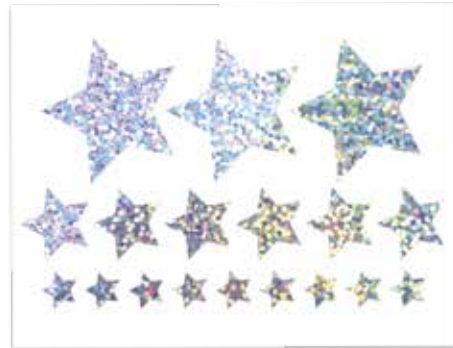

6

PROJECT #1

Test out your Cubes!

1 Turn on the Battery:

Powers all your projects!

2 Connect the Battery + LED:

Instant light!

3 Connect the Battery + Motor:

Get things revving!

4 Connect the Battery + LED + Motor:

Lights and action!

5 Connect the Motor + LED + Wheel:

Turn the wheel to generate electricity!

6 Connect the Battery + Motor + Wheel +

Wires: Your Circuit Cubes can take on anything!

1

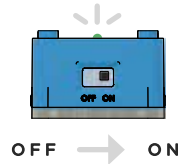

3

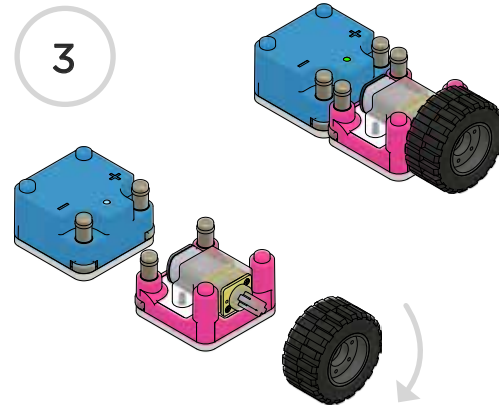

5

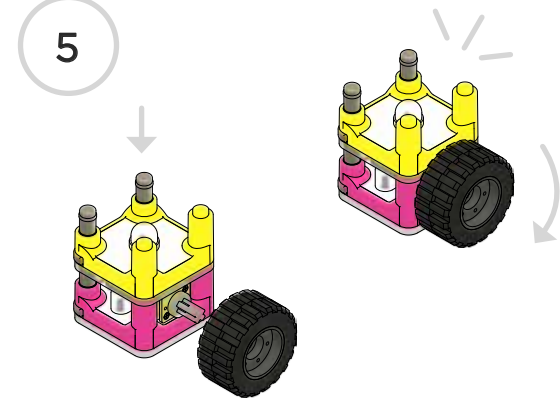

2

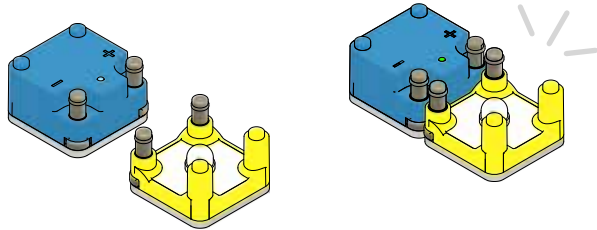

4

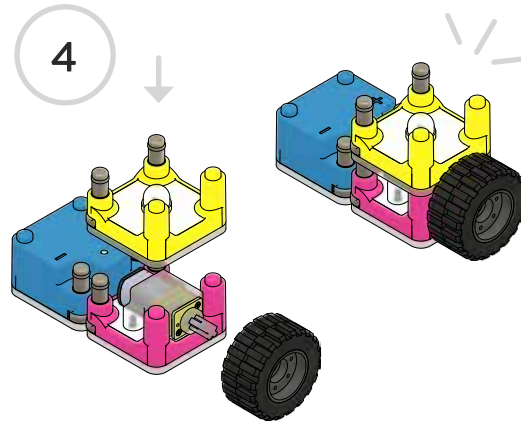

6

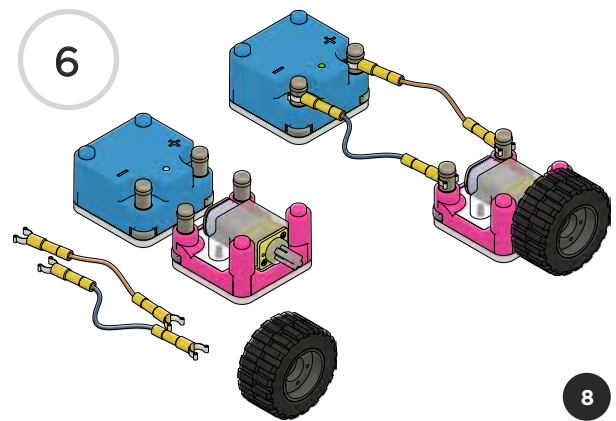

7

8

PROJECT #2

Make a flashlight!

MATERIALS

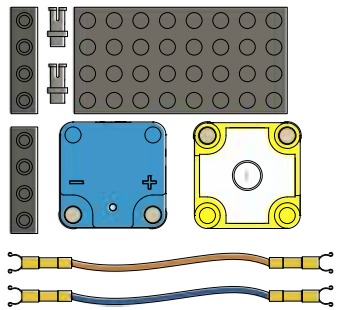

1

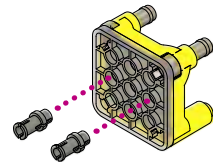

2

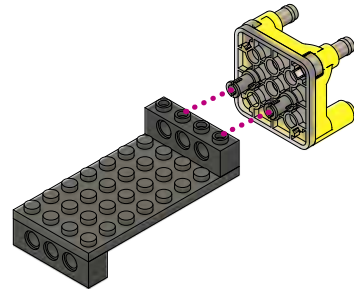

3

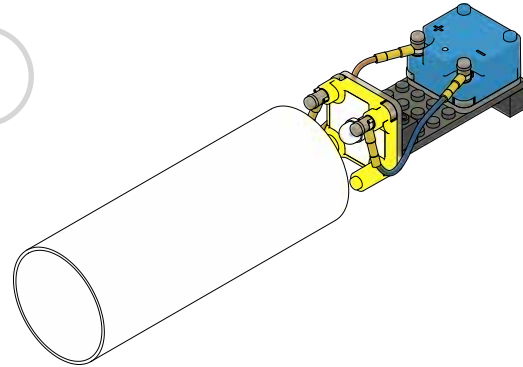

PROJECT #3

Make a hand-crank flashlight!

MATERIALS

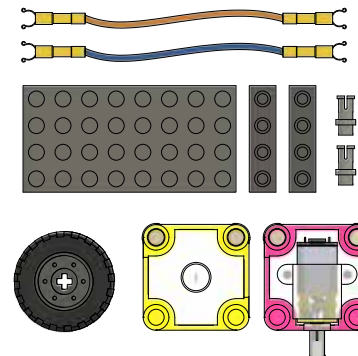

1

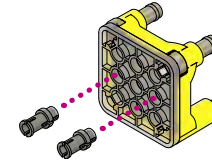

2

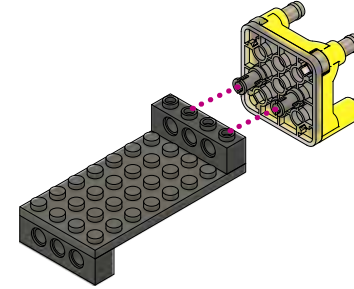

3

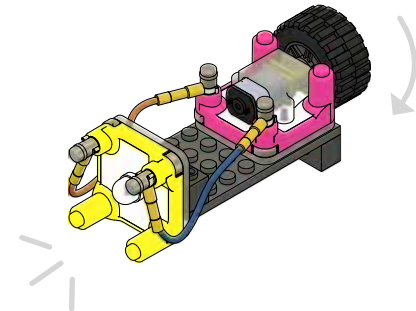

PROJECT #4

Make a GOBO flashlight!

MATERIALS

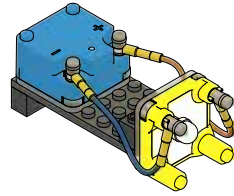
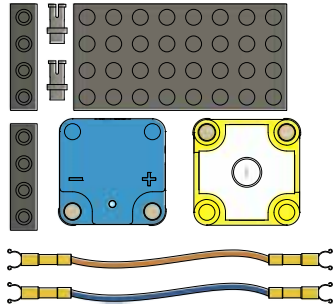

1

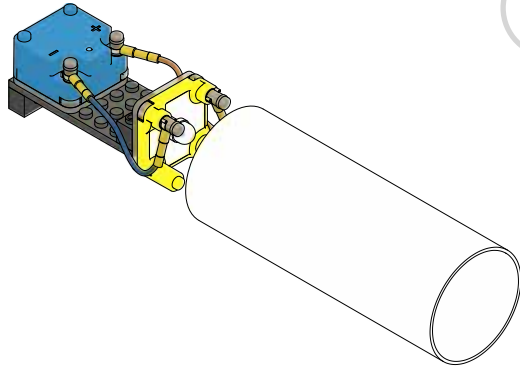

2

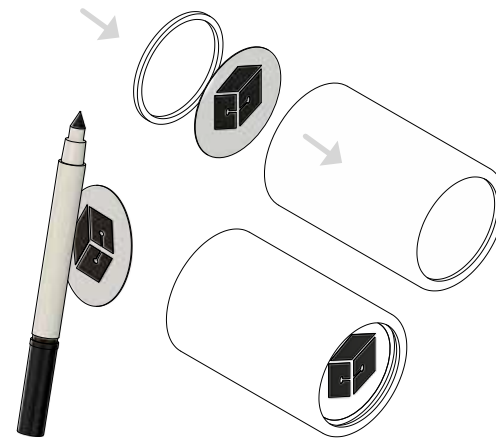

3

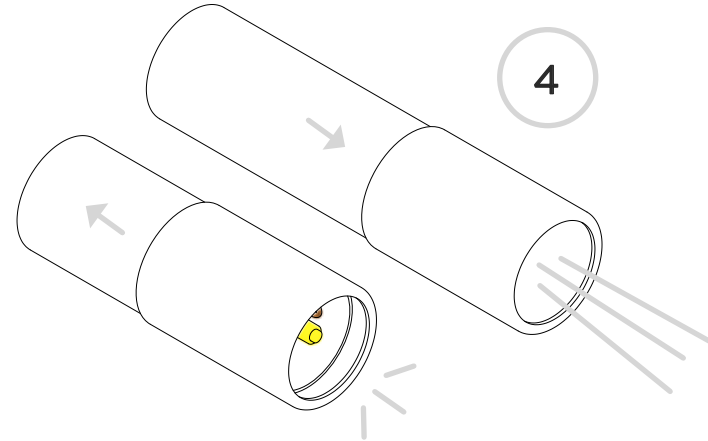

4

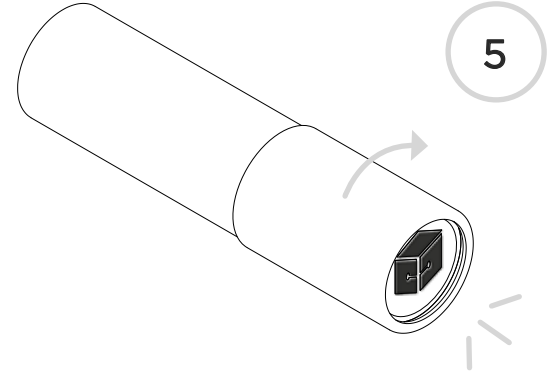

5

PROJECT #5

Make a 1-Marker Scribblebot!

MATERIALS

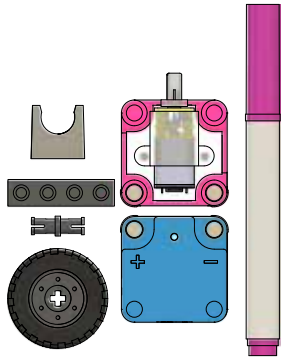

1

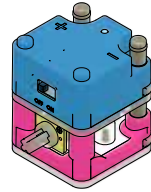

2

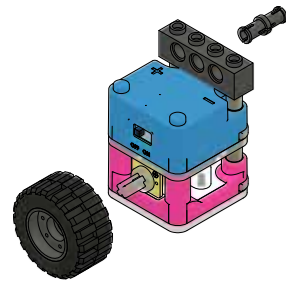

3

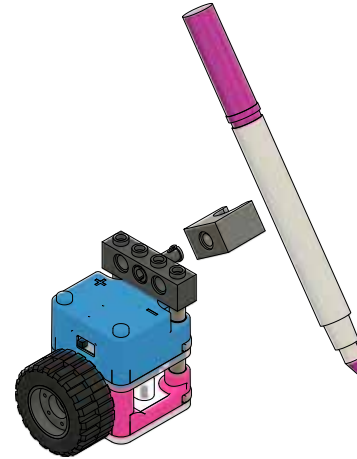

4

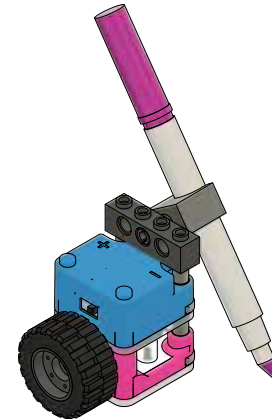

PROJECT #8

Build a chassis!

MATERIALS

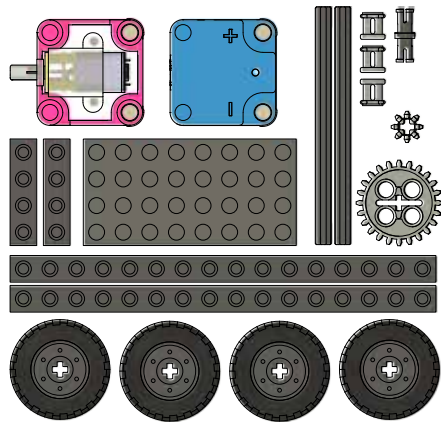

1

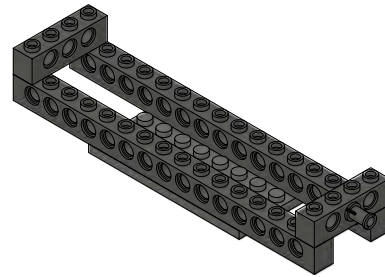

2

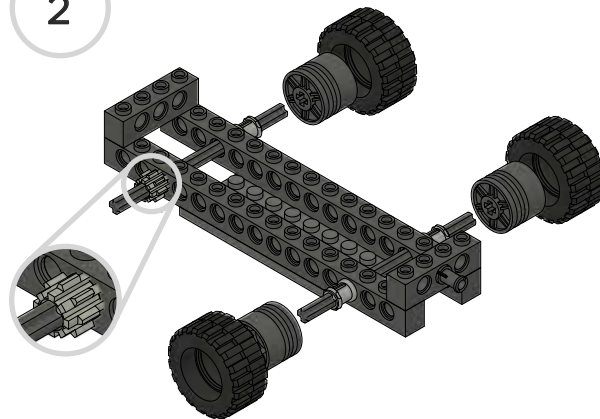

3

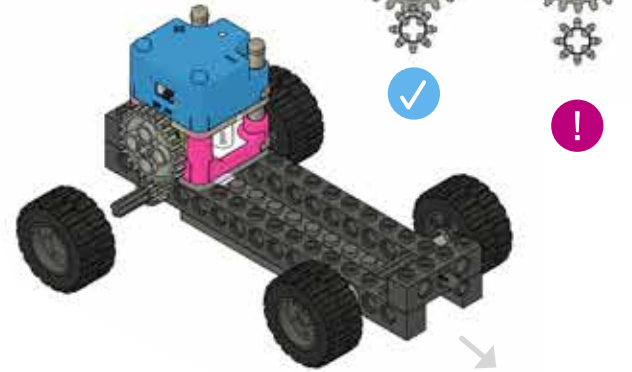

PROJECT #10

Build a tower!

MATERIALS

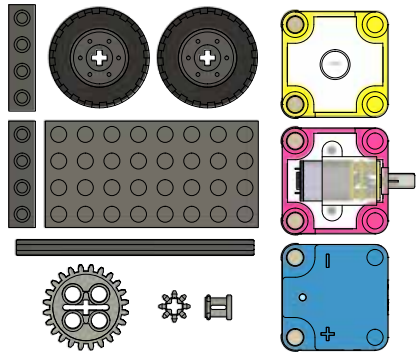

23

1

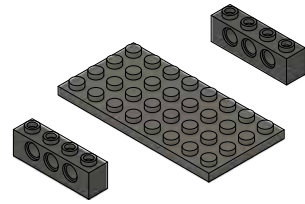

2

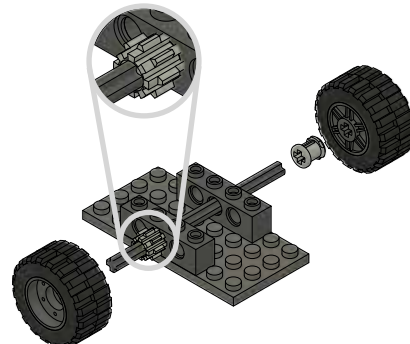

3

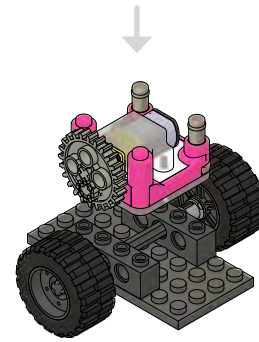

4

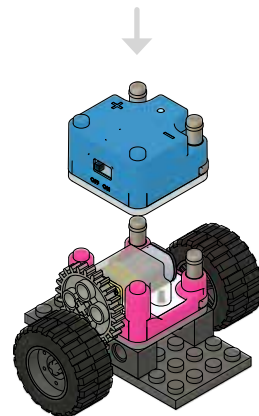

5

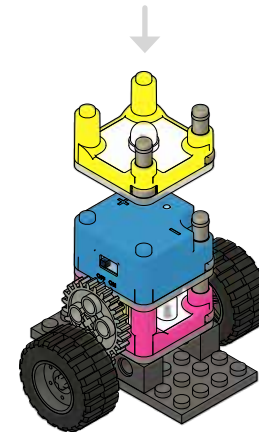

6

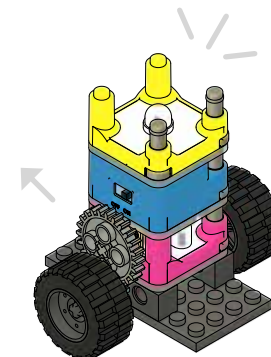

24

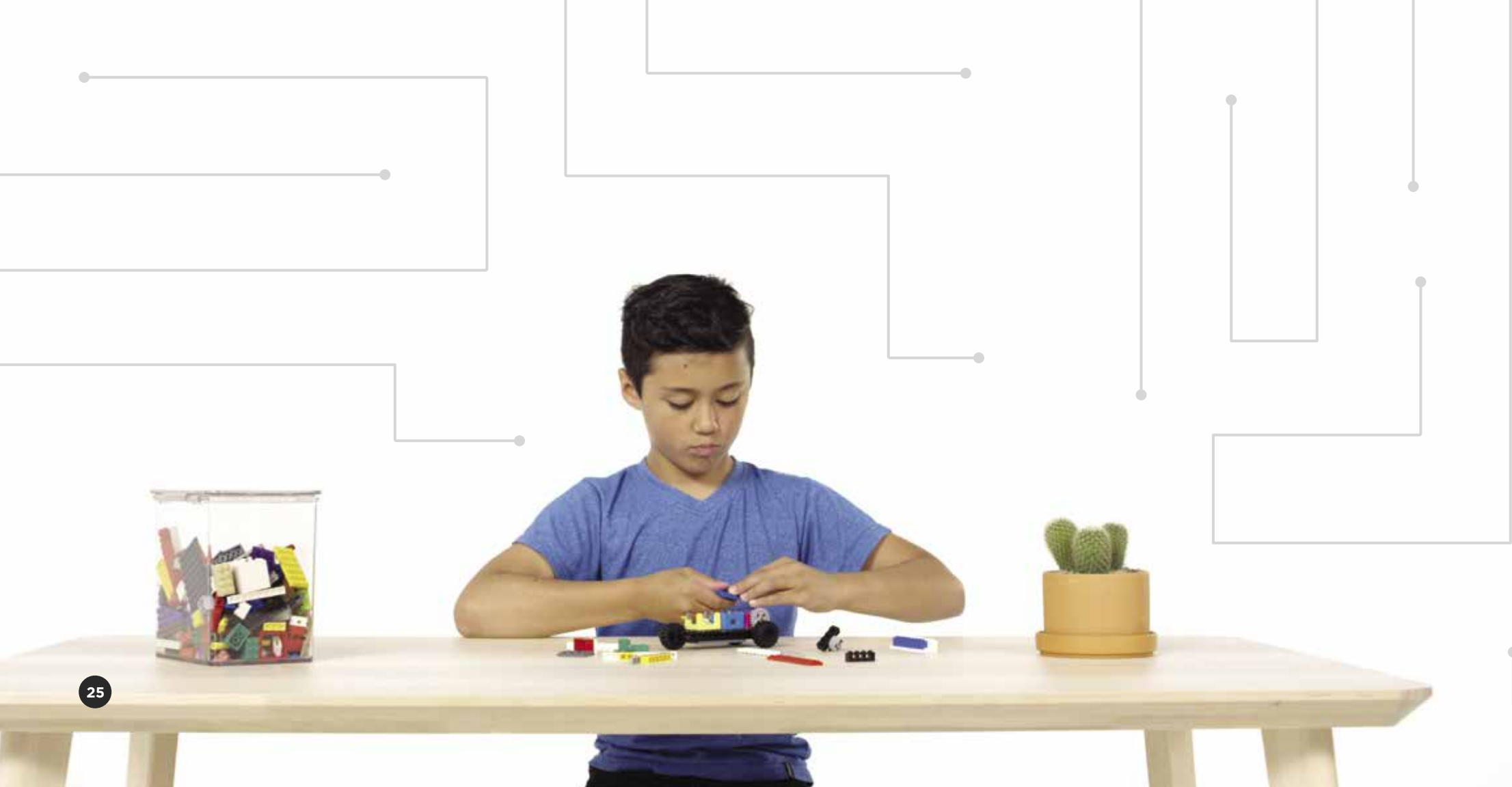

Circuit Cubes is a registered trademark of Tenka Labs. © 2016 Tenka Labs. All rights reserved. Other products and company names mentioned herein are trademarks of their respective companies. Patents pending. Images for illustration purposes only. Actual products may differ. Assembled in the U.S. from foreign and domestic parts. Made in China. Tenka Labs, Inc. 461C Coloma Street, Sausalito, CA 94965.

WARNING This product contains chemicals known to the State of California to cause cancer and birth defects (or other reproductive harm). **WARNING** This product contains small magnets. Swallowed magnets can stick together across intestines causing serious injuries. Seek immediate medical attention if magnets are swallowed or inhaled. **WARNING** Choking hazard—small parts. Not for children under 3 years. **WARNING** Lithium-ion batteries may overheat, explode or ignite, and cause injury. Do not connect the positive terminal and negative terminal of the battery to each other with metal objects. Do not expose battery to water or allow the battery to get wet. **WARNING** The battery is non-replaceable **WARNING** Circuit cubes are only intended to work with one battery cube in a circuit, parts may fail if you add multiple battery cubes in a circuit.

This toy shall only be used with a suitable transformer designated for toys having the following specifications: DC 5V and 500 mA charge rating. The transformer is not a toy. Toys liable to be cleaned with liquid are to be disconnected from the transformer before cleaning.

The toy is only to be connected to Class II equipment bearing the following symbol:  Packaging has to be kept since it contains important information.

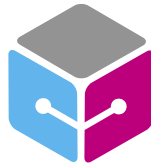

circuitcubes

TENKALABS.COM