

Monster Maker

BLUETOOTH CONTROL EXPLORER KIT

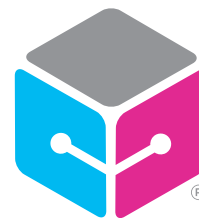

circuit
cubes

MEET THE CUBES!

Bring your toys to life with Circuit Cubes, the electronic building blocks that add power, motion, and light to your creations. Designed by STEM teachers, Circuit Cubes can turn a light on, power a motor, or make wheels spin — plus, they work with your LEGO® bricks.

BLUETOOTH

The Bluetooth Cube can function like a standard Battery Cube to power all the outputs at the same time with the 3-way switch in the ON position. Move the switch to the Bluetooth position for broadcast mode [flashing blue LED] to pair the Cube with your device. Once connected [solid blue LED], you can control the three outputs [A | B | C] independently using the app.

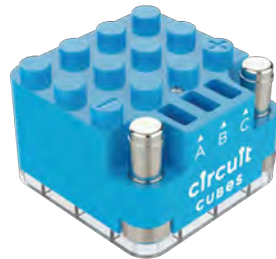

CUBITS

Cubit Geared Motors are compact and powerful. The tiny planetary gears inside reduce the high speed motor to about 160 RPMs (rotations per minute) to provide torque to gears, wheels, etc. Three (3) ports around the Cubit Geared Motor allow maximum versatility to connect the wires from the Bluetooth Cube.

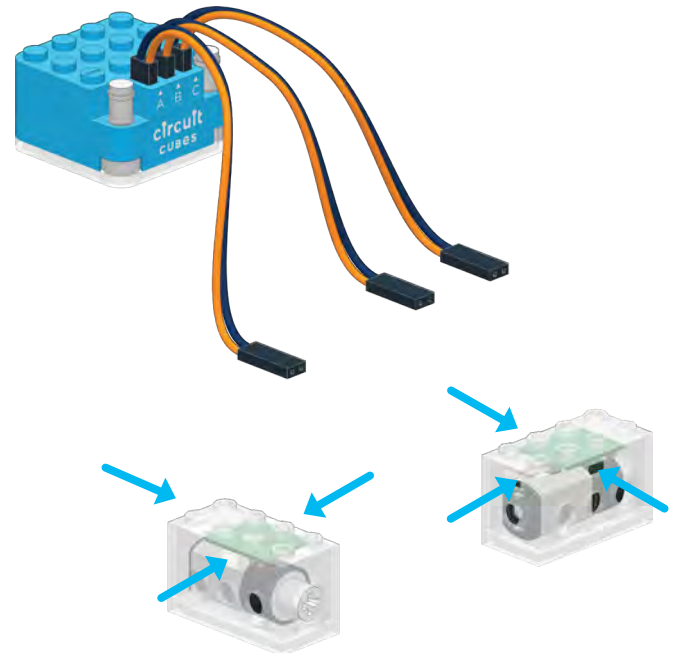

BATTERY MODE



Flip the switch to the right to power your creation in standard battery mode. A solid green light [●] indicates that the Bluetooth Cube is powered on. Outputs [A | B | C] are on, and you cannot control voltage.

PROTECT

Your Bluetooth Cube has short circuit protection for when you cause a shortage. Power will be disabled and the top LED will flash green [●] and blue [●]. You will hear a beeping sound until the short is removed.

CHARGING

To charge your Bluetooth Cube, plug the provided USB cable into the charging port on the side, and connect it to a standard USB port. The LED will turn red [●] while charging and green [●] when charging is complete.

BLUETOOTH MODE



You can control the three outputs [A | B | C] independently with the Circuit Cubes app. Each output allows you to control and power different parts of the build. Similar to the metal posts on the Cubes, each output has positive and negative polarity. This makes the Motor move, either clockwise or counterclockwise.

BLUETOOTH [●]

Flip the switch to the left to control your creation via the free Circuit Cube app — find it in the Apple App Store or Google Play Store.

PAIRING

A blinking blue light indicates that the Bluetooth Cube is pairing with your device. When the light is solid blue [●], it's connected.

DEVICE PAIRING

1 Download the free Circuit Cubes app from the Apple or Google Play stores. 2 Turn on your device's Bluetooth and set the Bluetooth Battery to the Bluetooth icon. 3 In the Circuit Cubes app, press the Bluetooth icon in the upper right corner of the home screen. 4 If no Cubes appear, tap the refresh icon. 5 Tap the Cube you wish to control.

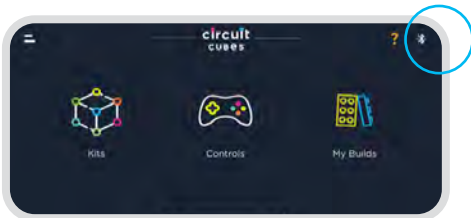

BLUETOOTH
ICON

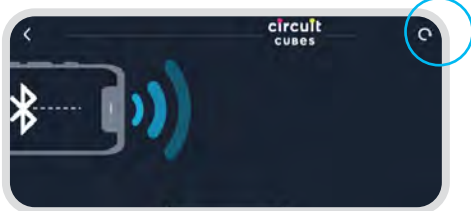

REFRESH
ICON

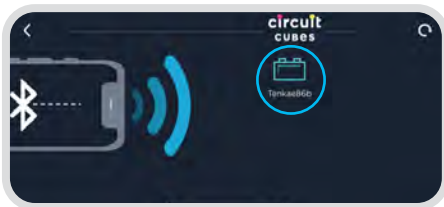

TAP CUBE

OUTPUTS

The Bluetooth Cube has three outputs [A | B | C]. In Bluetooth Mode, output A and the metal posts are the same, and are linked when powered on.

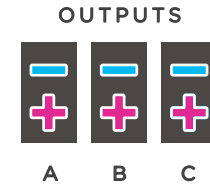

CONTROLS

Power the three outputs [A | B | C] using Tank, Tinker, Gamepad or Code in the Controls section of the App. The correct output settings to control each build is located at the end of each section.

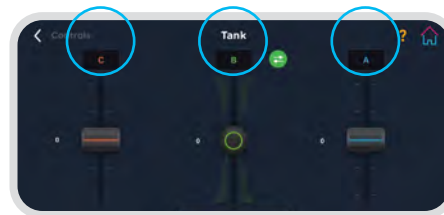

XM-A1



1

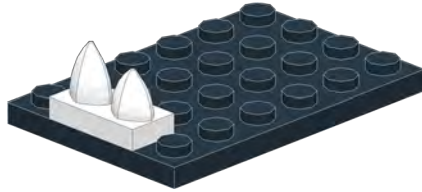

1

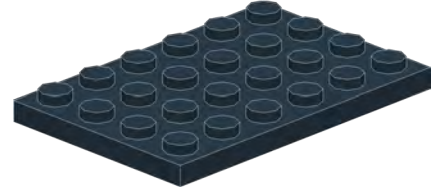

1

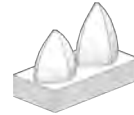

1:1 SCALE



2

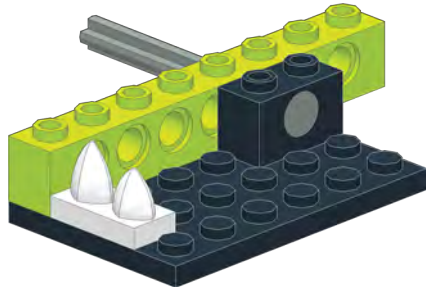

1



5

1

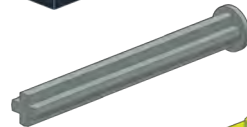

1

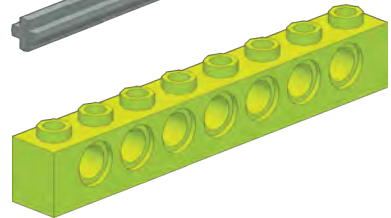

3

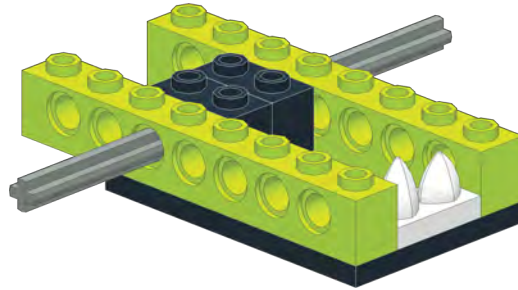

1



1

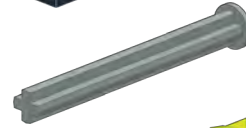

5

1

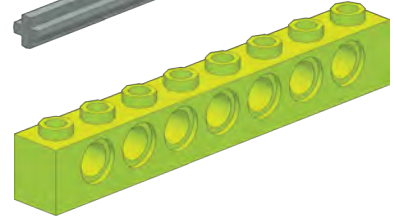

1:1 SCALE



4

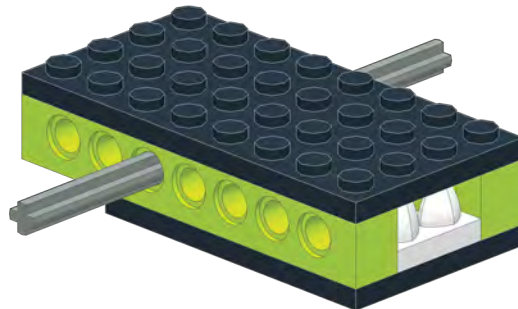

1



5



2x

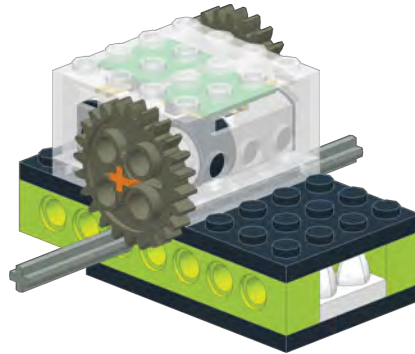

2



2



2



6

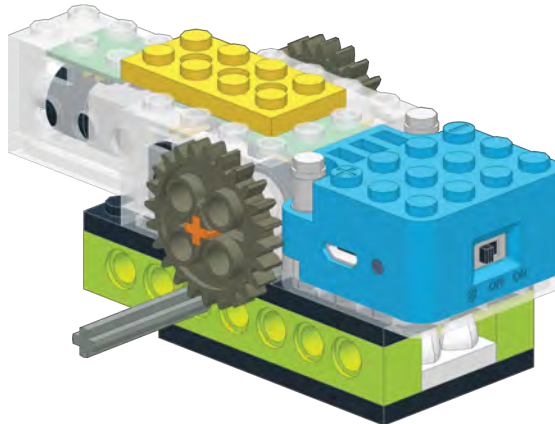

1



1



1



7

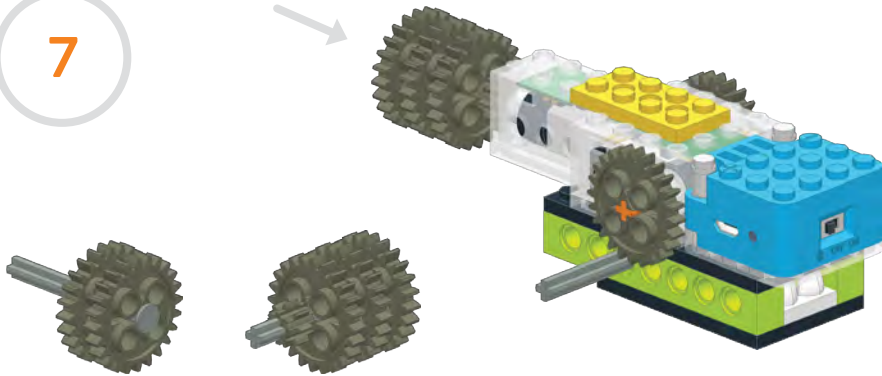

- 1
- 3
- 1
- 5



8

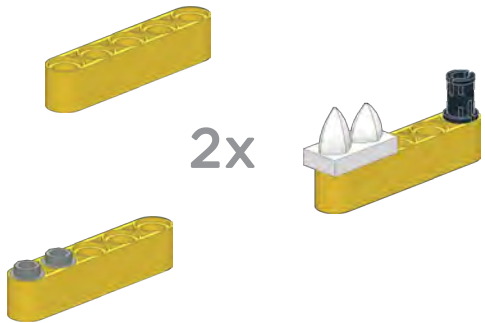

- 4
- 2
- 2
- 2

9

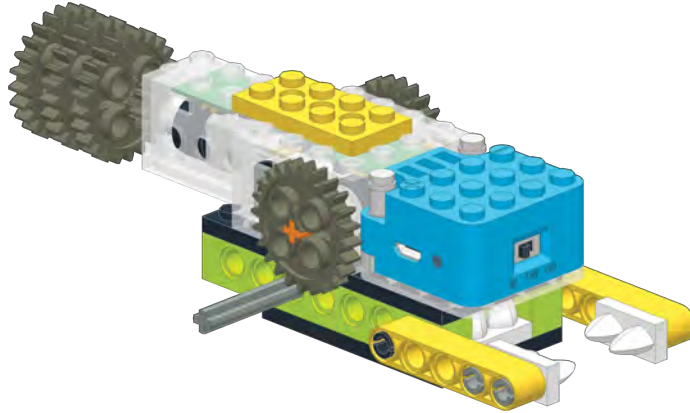

2



1

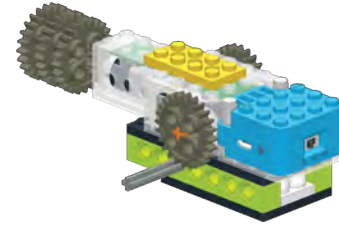

10

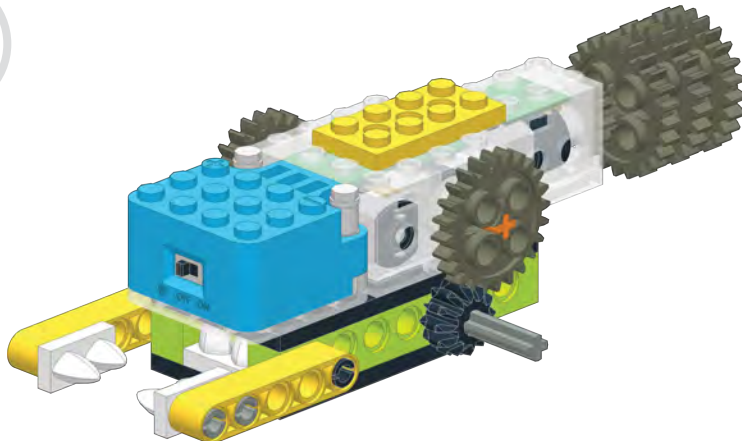

1



11

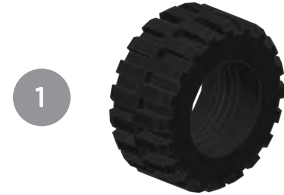
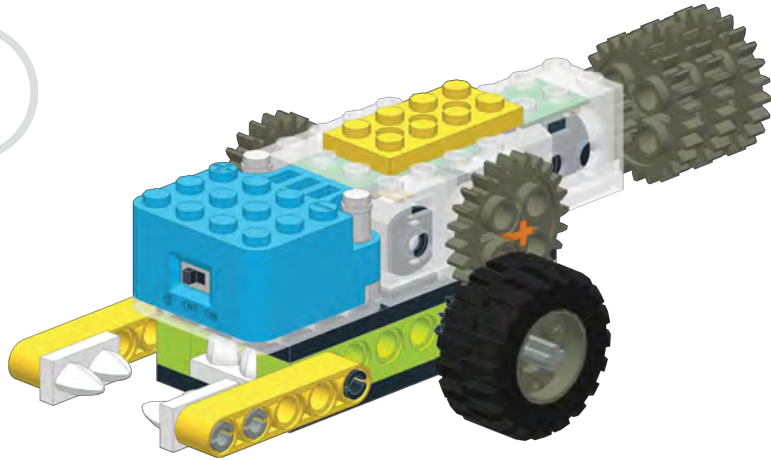

12



13

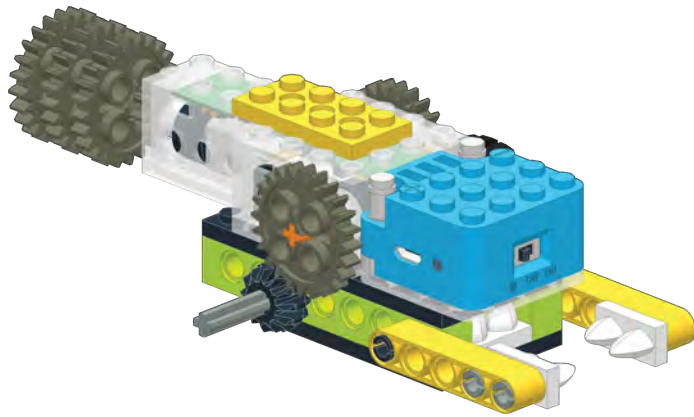

1

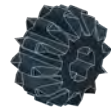

14

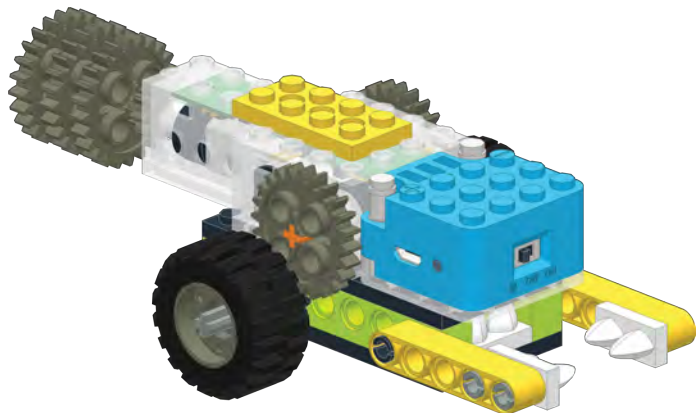

1



1



15

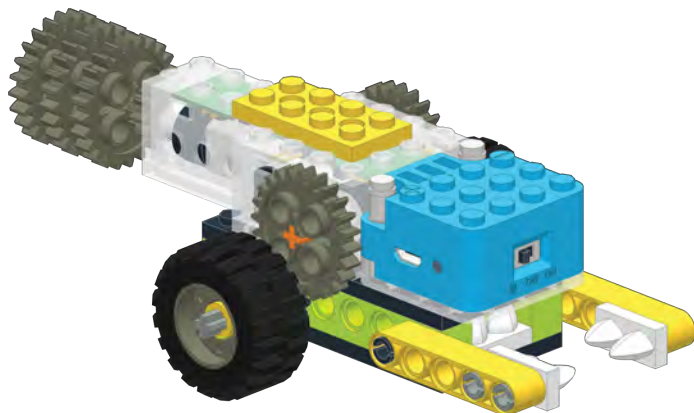

16



17

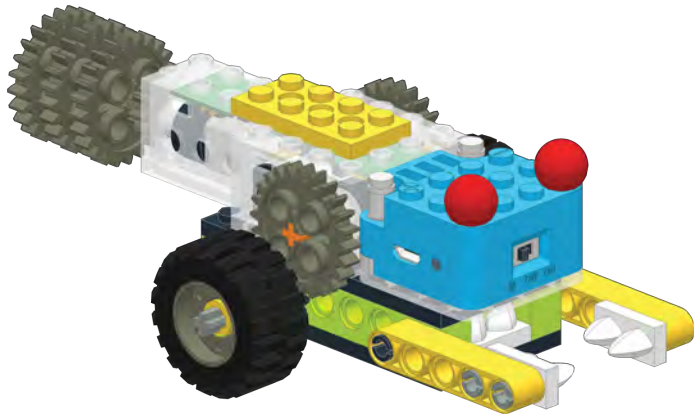

2



18

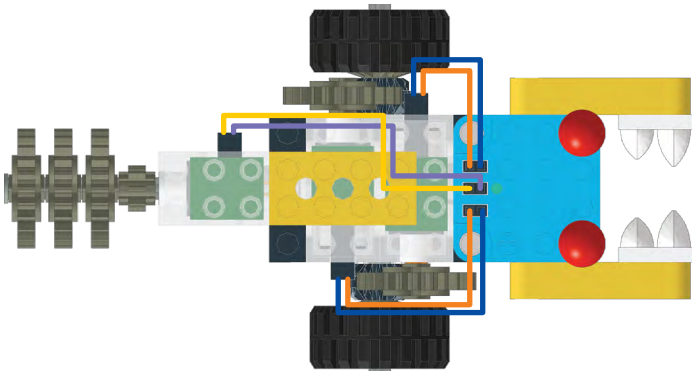

1

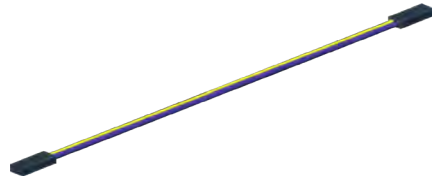

2



XM-A1 CONTROLS

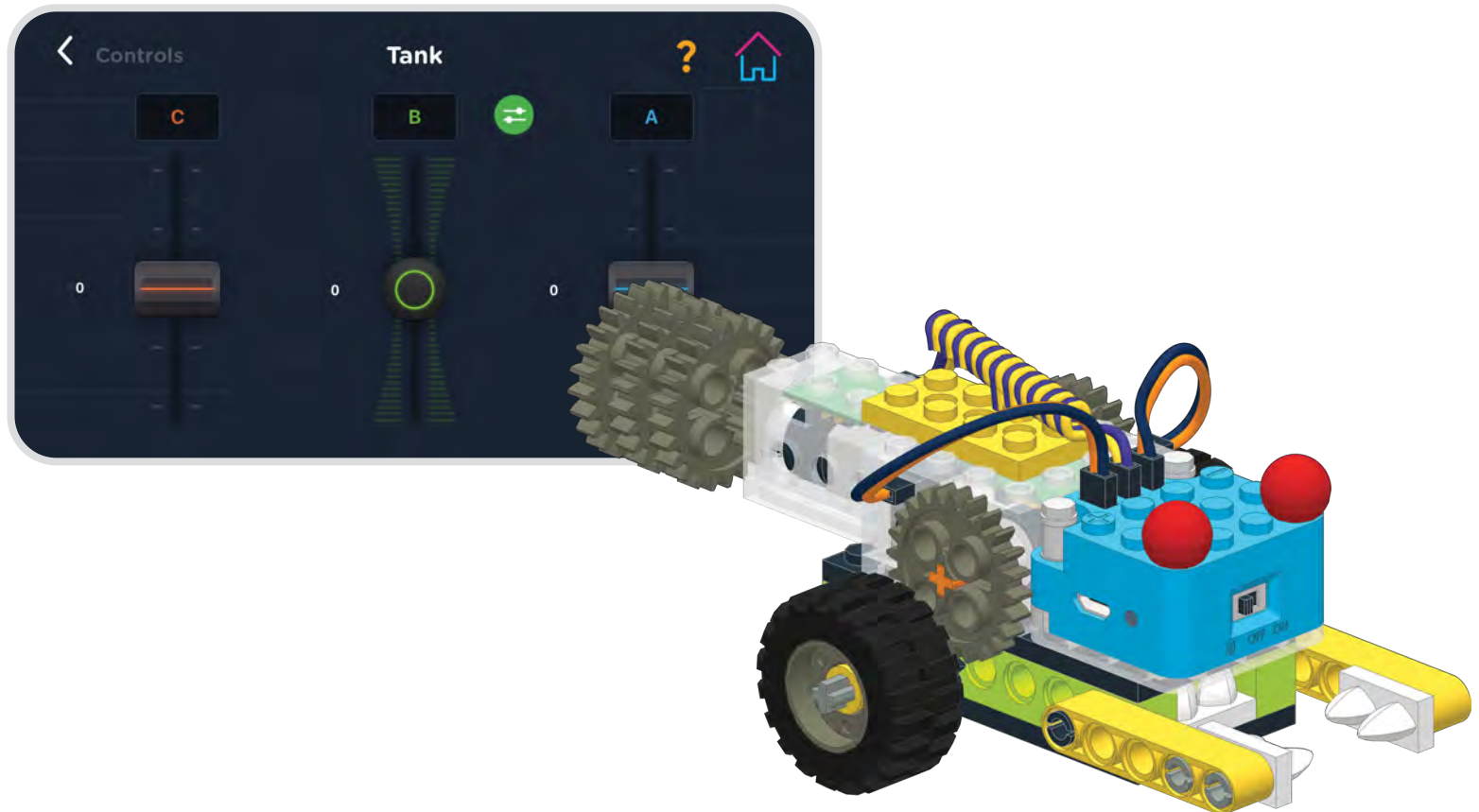

XM-A2

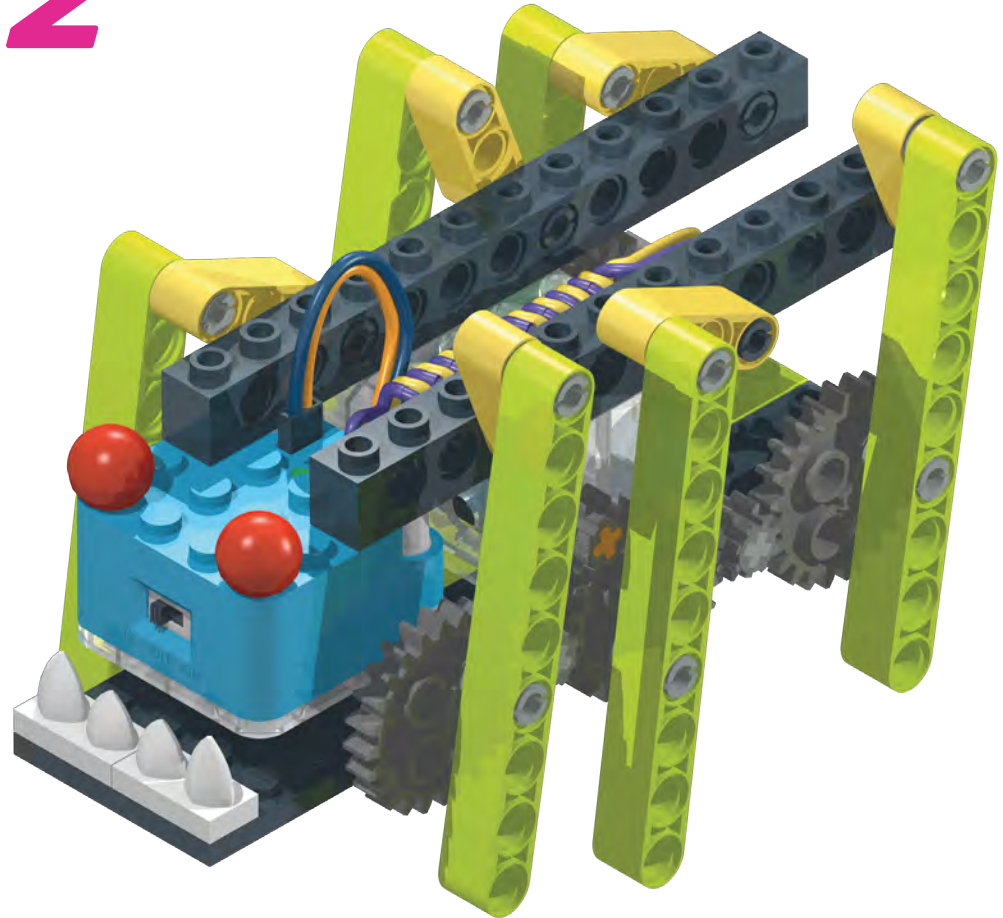

1

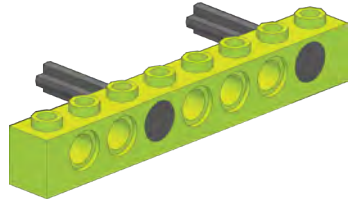

1

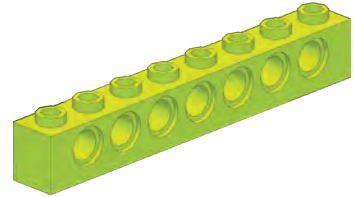

2



3



2

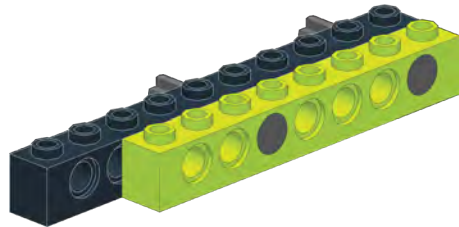

1



3

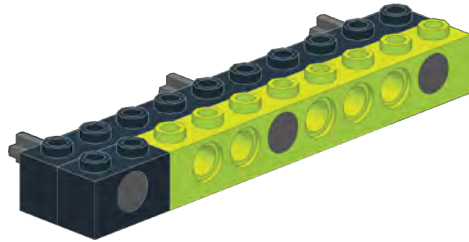

1



1



3

1:1 SCALE



4

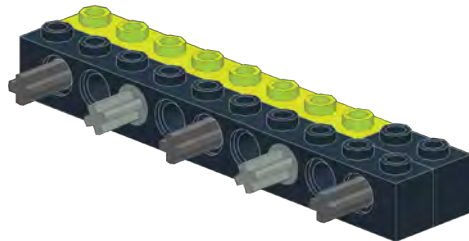

2



5

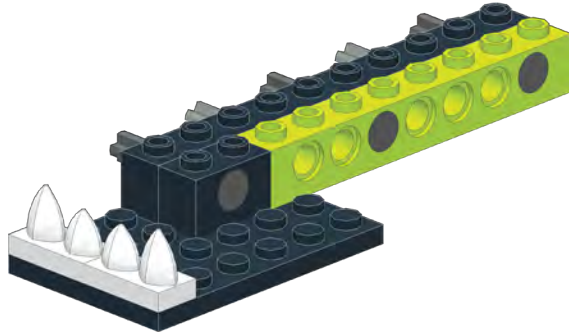

1



2

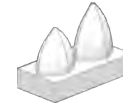

1:1 SCALE

6

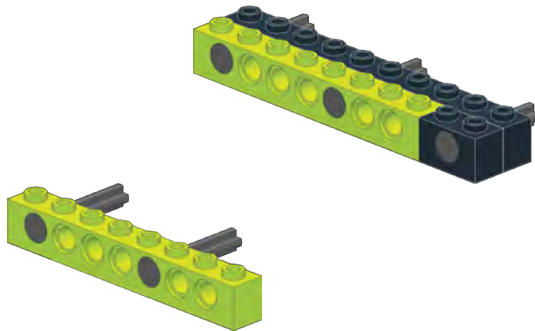

3



1

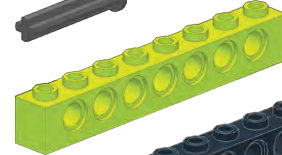

1

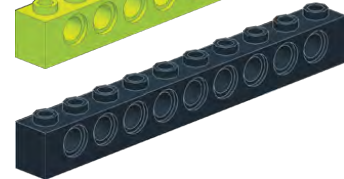

1



7

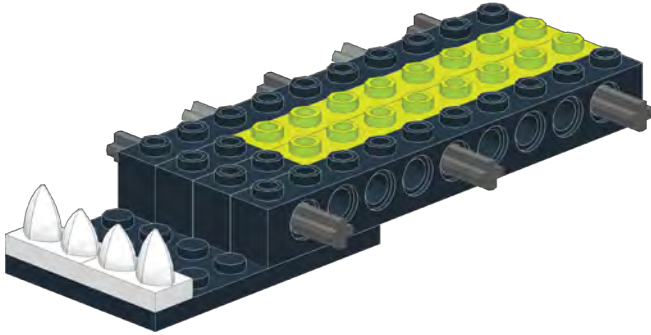

1

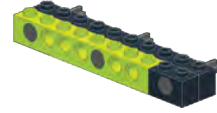

1

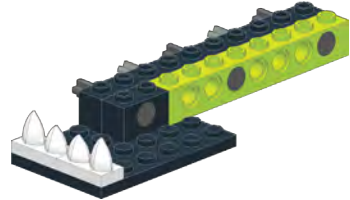

8

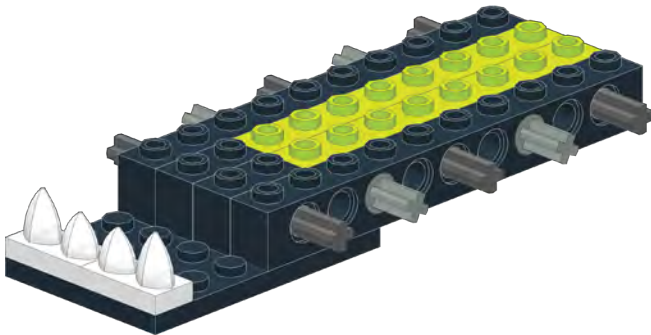

2



9

2x

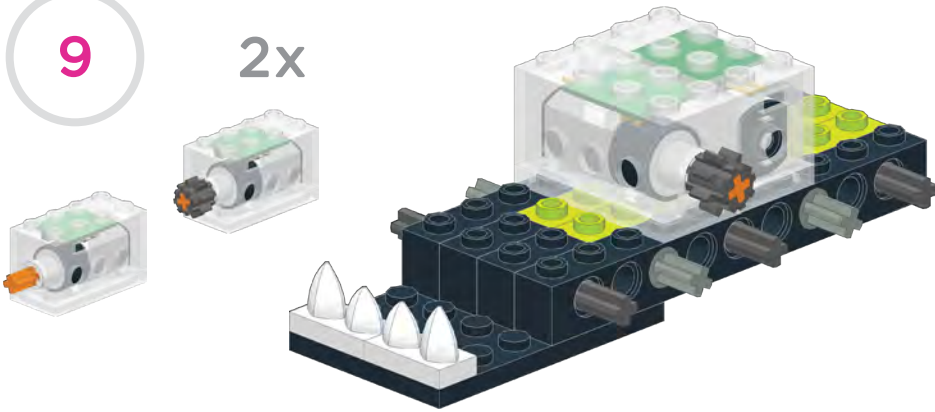

2



2

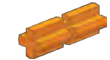

2



10

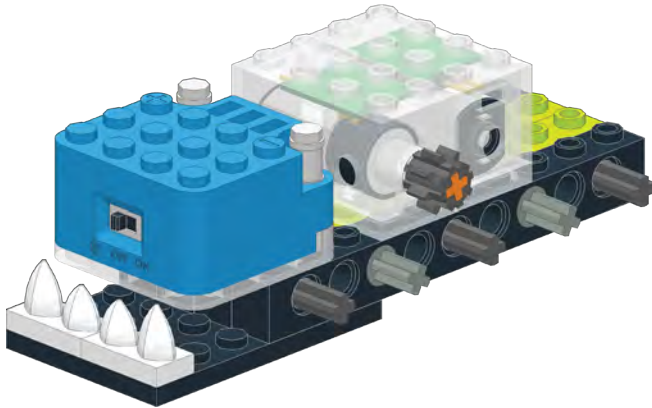

1

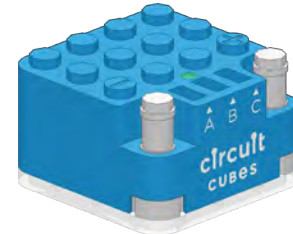

11

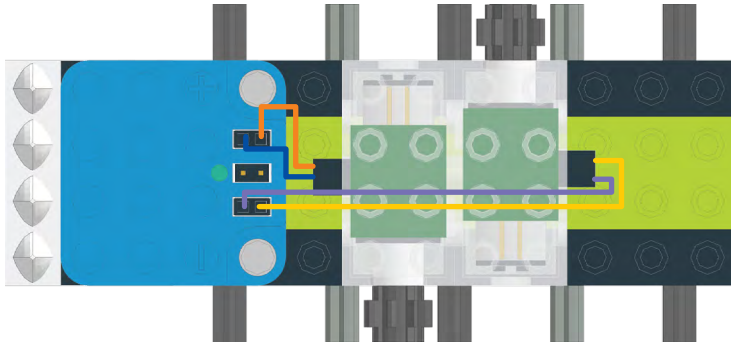

1



1



12

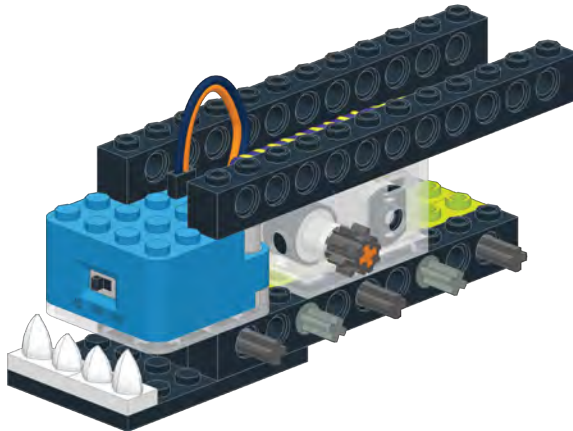

2



13

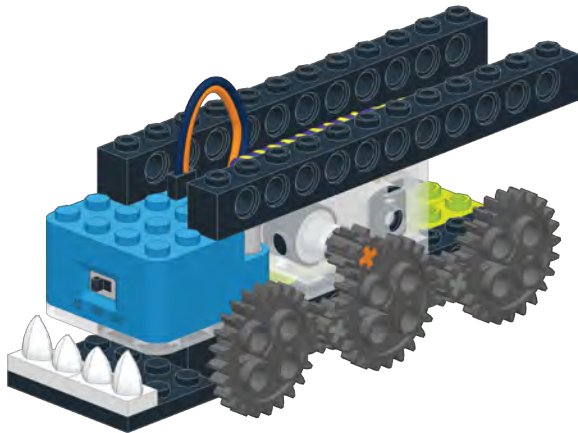

3



2



14

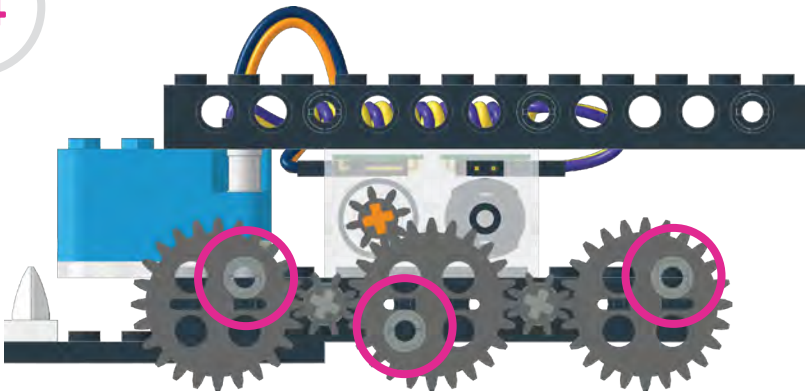

3



3



15

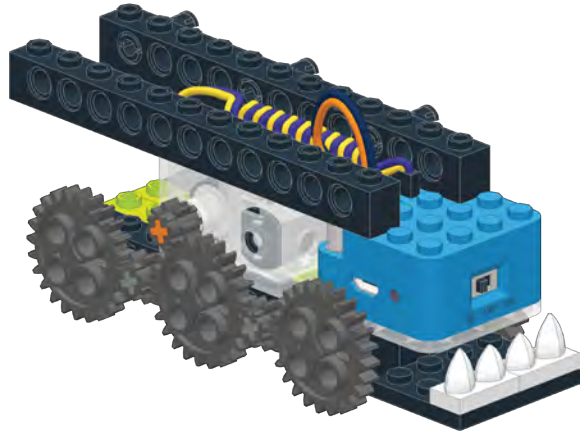

3



2



16

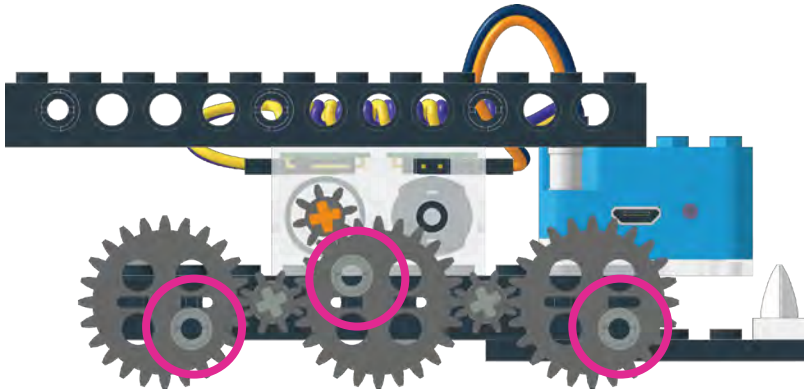

3



3



17



3



3

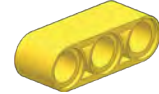

18

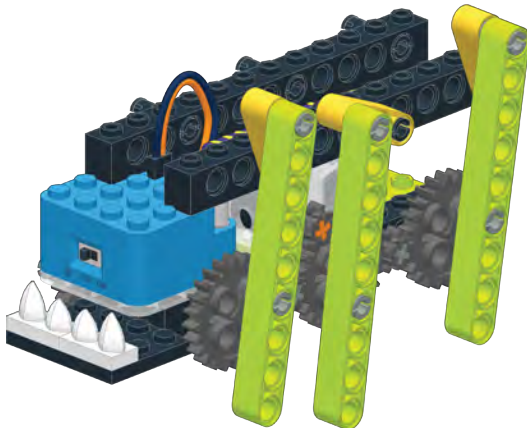

3

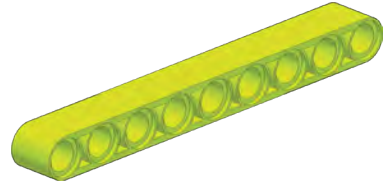

19



3



3

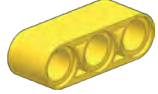

20

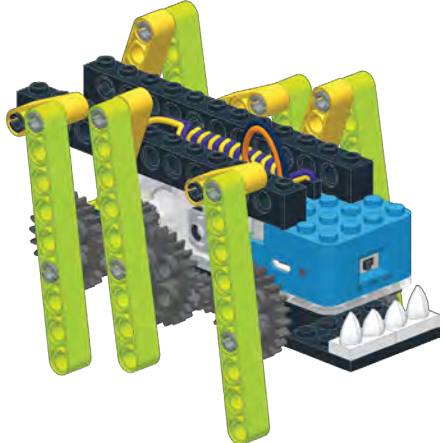

3

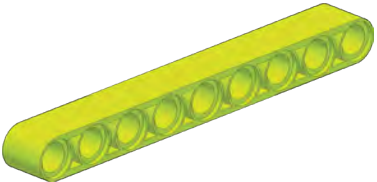

21

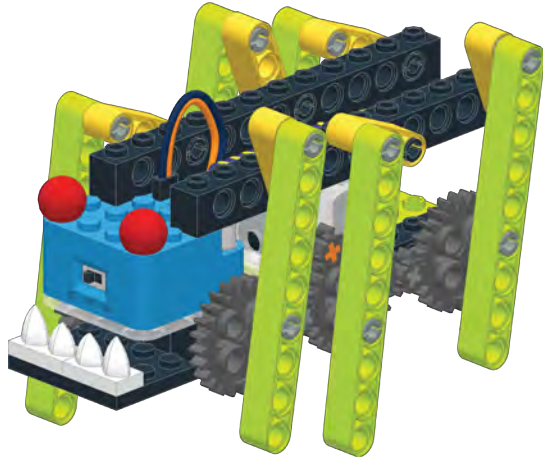

2 

XM-A2 CONTROLS

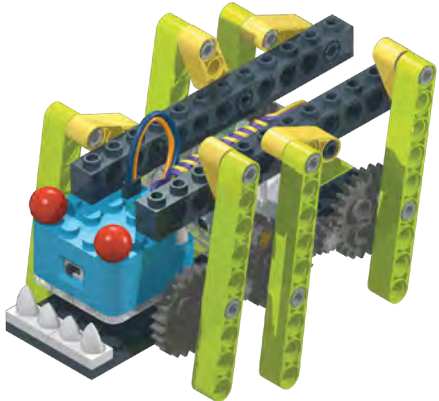
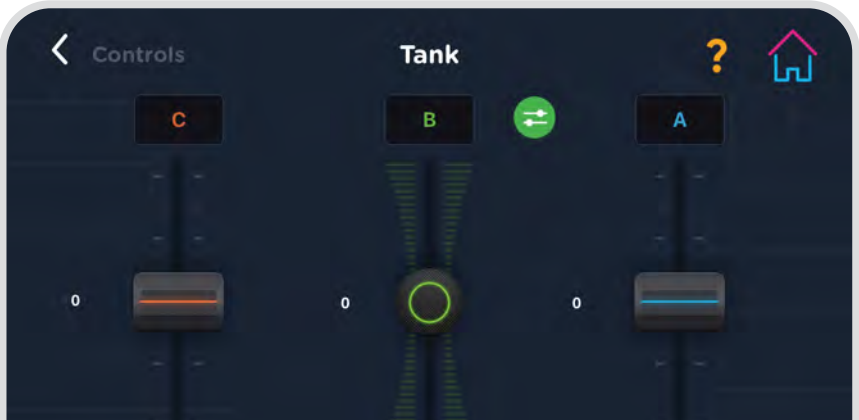

XM-A3

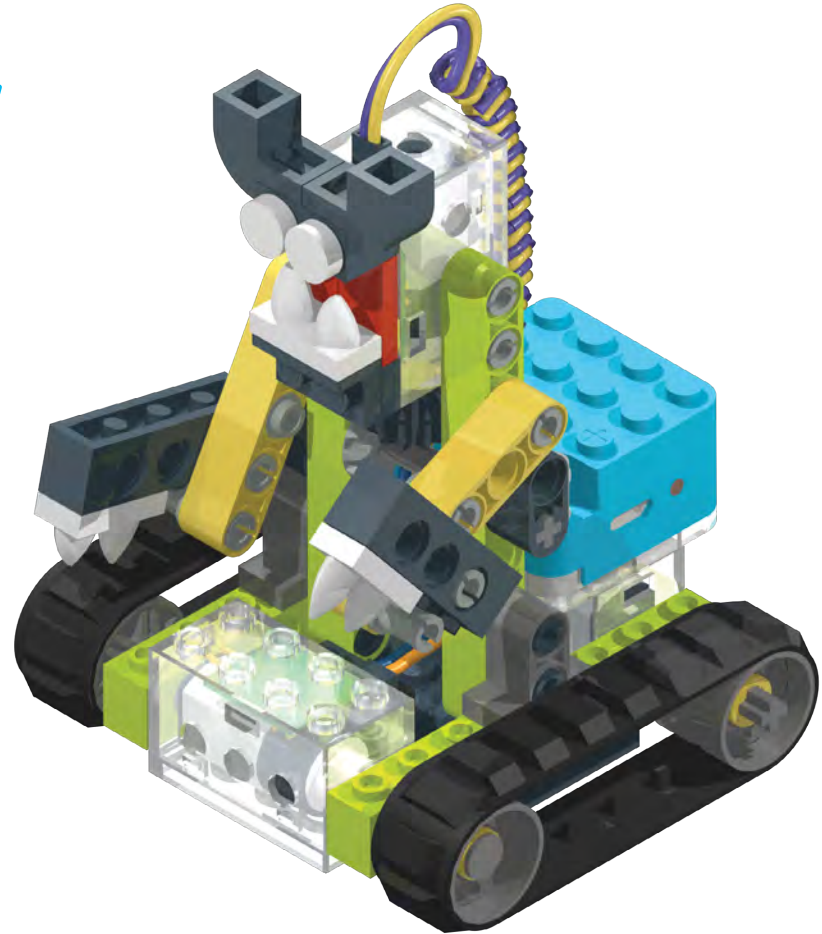

1

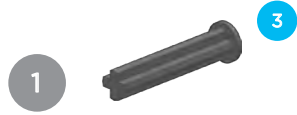
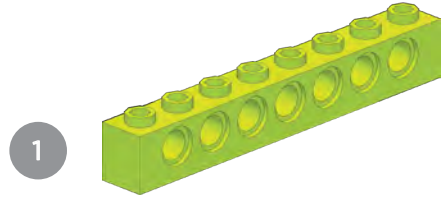
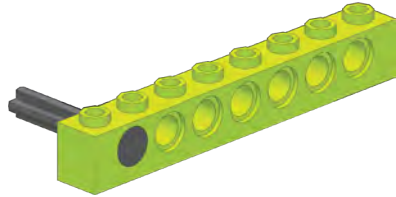

2

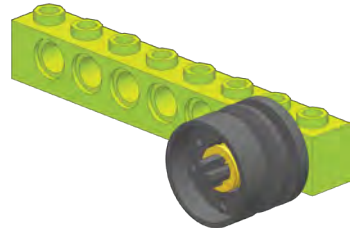

3

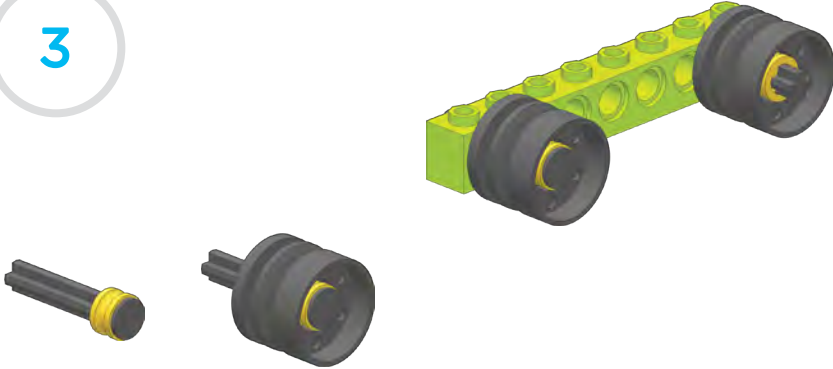

1



1



3

1



1:1 SCALE



4

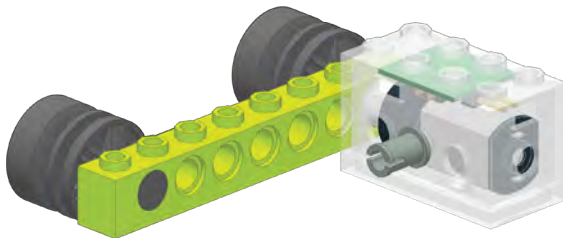

1



1



5

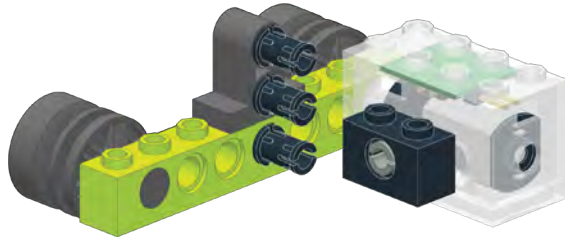

1



1



3



6

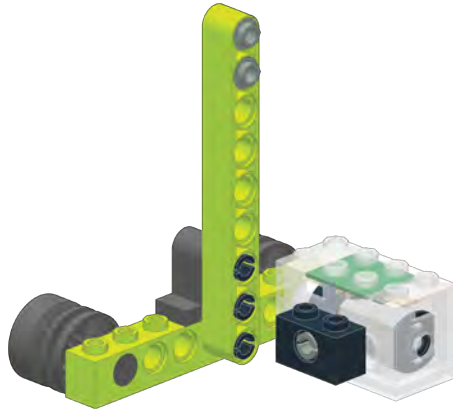

1

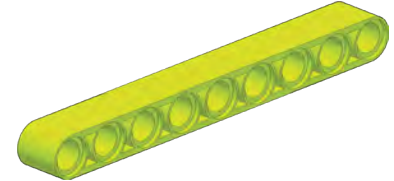

2



7

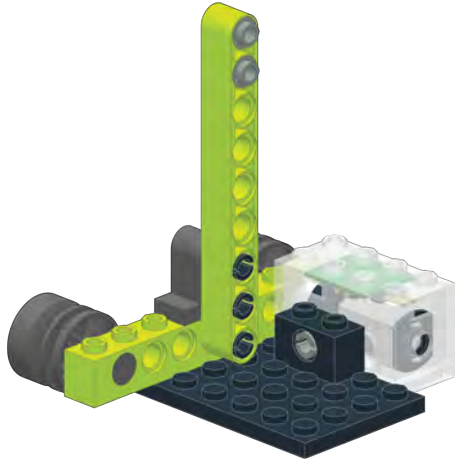

1



8

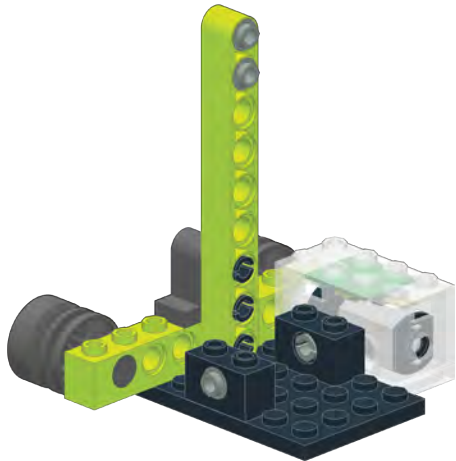

1



1



9

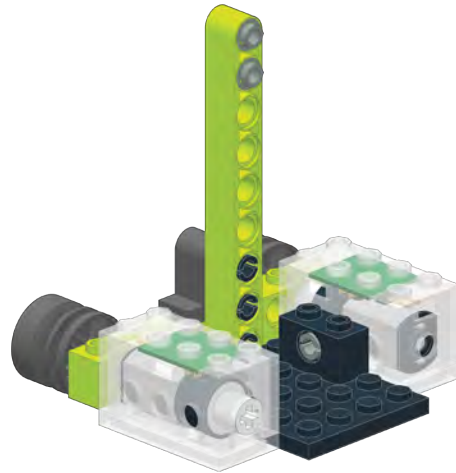

1



10

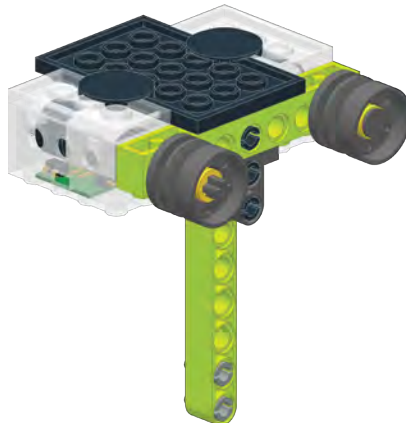

2



11

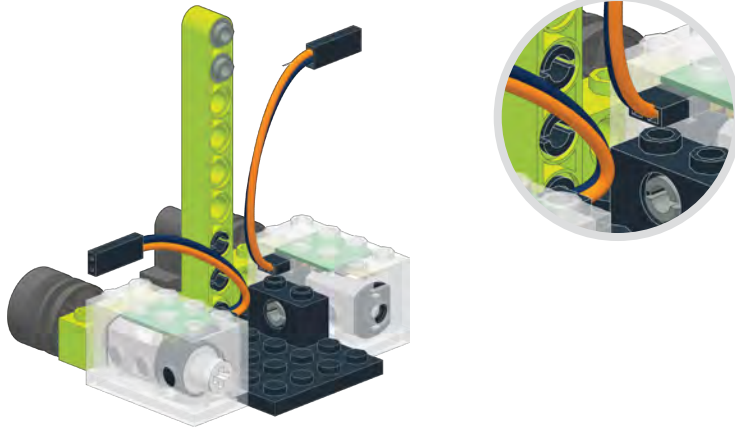

2



1:1 SCALE



12

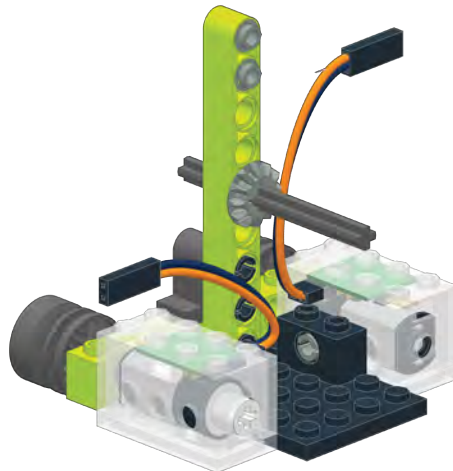

1



1



6

13

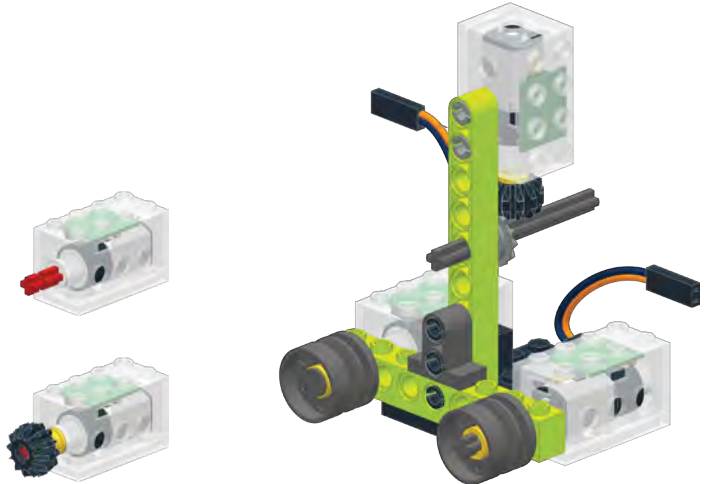

1



1



1

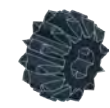

1



14

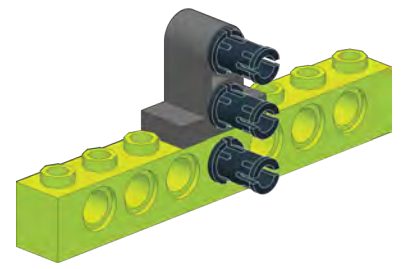

1

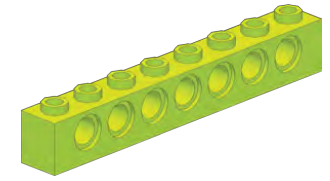

1





3



15

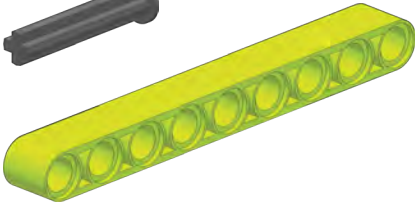

- 1  3
- 1 
- 2 

1:1 SCALE 

16

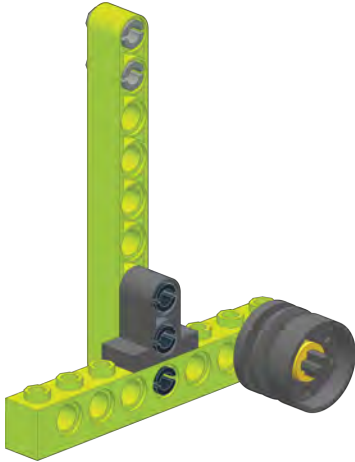

- 1 
- 1 

17

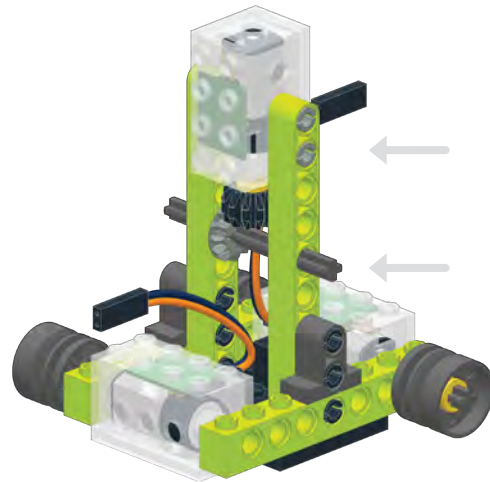

1



1



1:1 SCALE



18

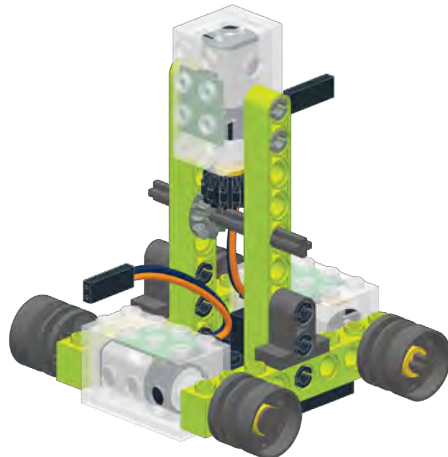

1



1



3

1



19

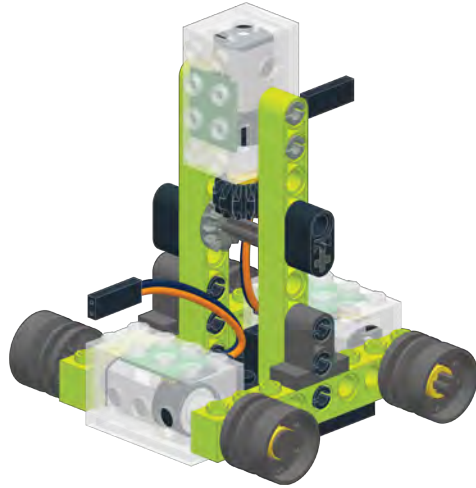

20

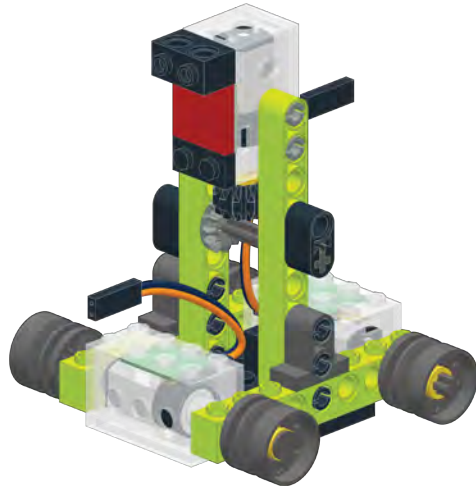

21

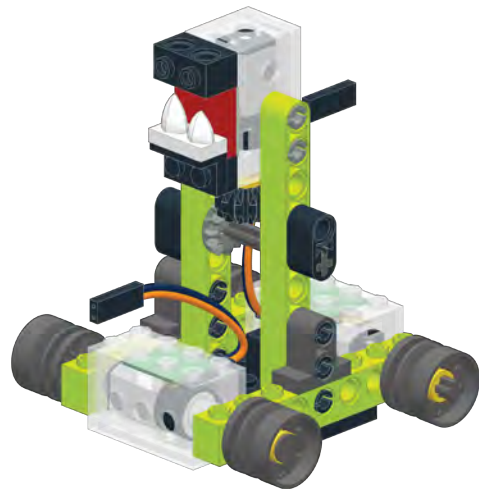

22

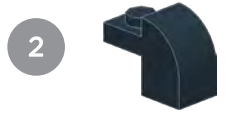
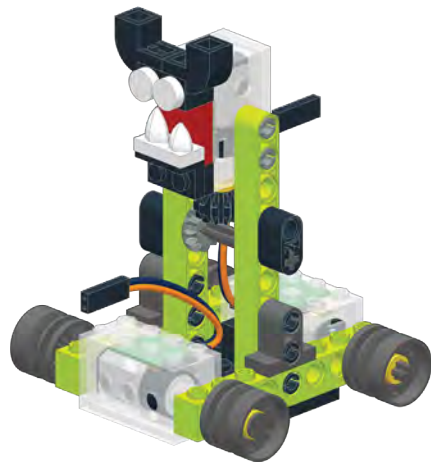

23

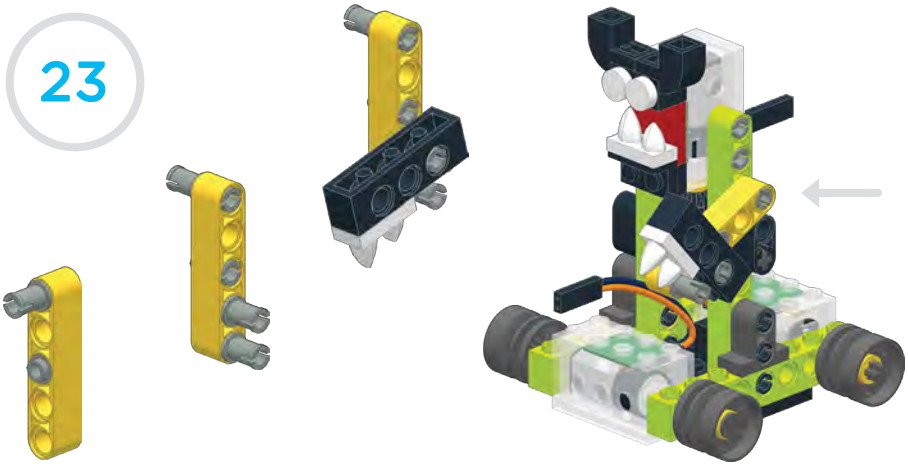

- 3
- 1
- 1
- 1
- 1

24

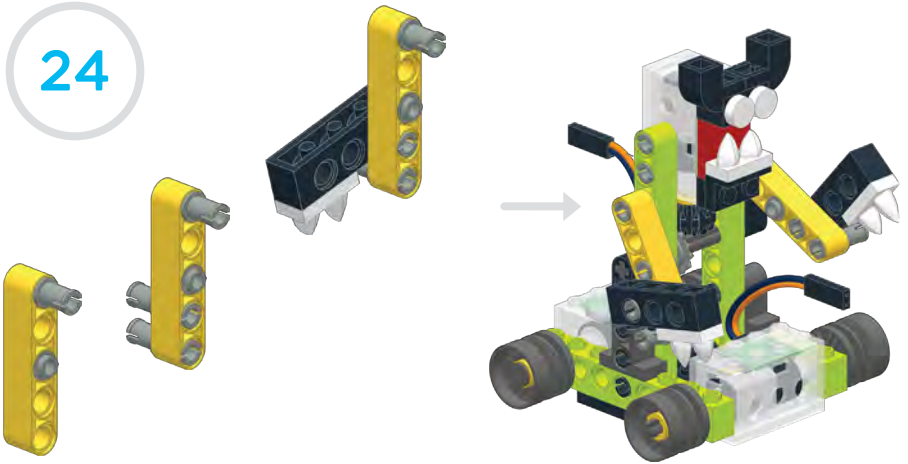

- 3
- 1
- 1
- 1
- 1

25



2



26



1

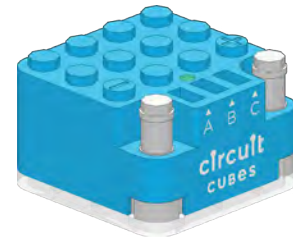

27

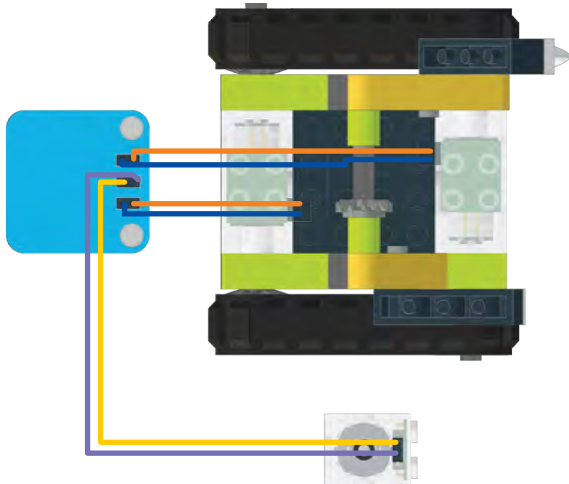

1

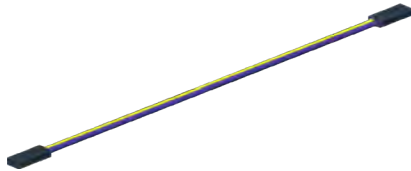

XM-A3 CONTROLS

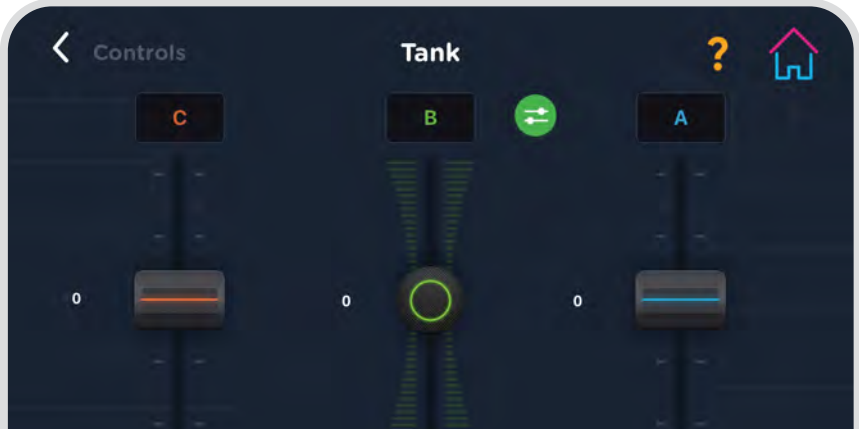

***FOLLOW @CIRCUITCUBES
FOR BUILD INSPIRATION***



CIRCUITCUBES.COM/BUILDS

PARTS

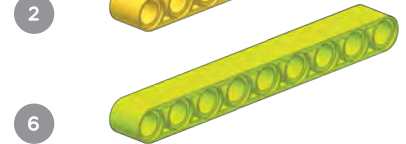
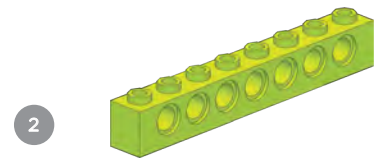
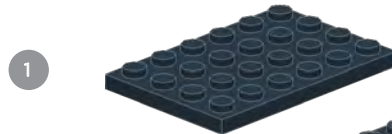
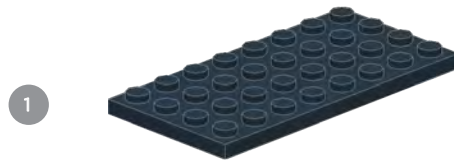

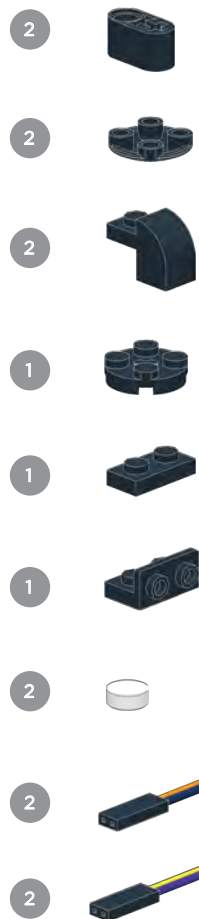
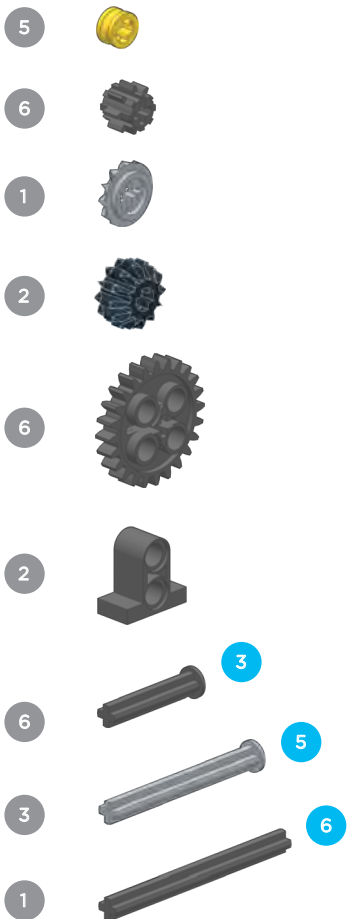

LEGAL

Tenka Inc. / 291 School Street, Suite 3 / Willits, CA 95490.
Designed by Tenka Inc. in California, USA. Assembled in China.
Please retain this information for future reference. Images for illustration purposes only. Actual product may differ.

PATENTS Circuit Cubes is a registered trademark of Tenka Inc. ©2021 Tenka Inc. All rights reserved. Patent approved. For details visit circuitcubes.com/patents.

SAFETY Handle Circuit Cubes with care. They contain sensitive electronic components, including batteries, and can be damaged or cause injury if dropped, burned, punctured, crushed, disassembled, or if exposed to excessive heat or liquids. Do not use damaged Circuit Cubes.

BATTERIES The battery is non-replaceable. Do not attempt to replace the batteries yourself. You may damage the batteries, which can overheat and cause injury. Do not expose battery to water or allow the battery to get wet. Circuit Cubes are only intended to work with one Battery Cube in a circuit — parts may fail if you add multiple Battery Cubes in a circuit.

DISPOSAL The lithium-ion polymer in your Bluetooth Cube should be recycled by Tenka Inc. or an authorized service provider. For more information about Tenka Inc. lithium-ion batteries, go to: circuitcubes.com/pages/cubecare.

BLUETOOTH The Bluetooth® word mark, BLE® and affiliated logos are registered trademarks owned by Bluetooth SIG, Inc, and any use of such marks by Tenka Inc. is under license. Apple® and the Apple logo are trademarks of Apple, Inc., registered in the U.S.A. and other countries. App Store® is a service mark of Apple, Inc. Android®, Google Play™ and the Google Play logo are trademarks of Google, Inc. Not all Bluetooth® and BLE® devices are compatible. Go to: circuitcubes.com/app for a list of compatible devices and more information.

COMPLIANCE Regulatory Compliance Information, FCC Compliance Statement: This device complies with part 15 of the FCC rules. Operation is subject to the following two conditions: (1) This device may not cause harmful interference, and (2) this device must accept any interference received, including interference that may cause undesired operation. Note: This equipment has been tested and found to comply with the limits for a Class B digital device, pursuant to part 15 of the FCC rules. These limits are designed to provide

reasonable protection against harmful interference in a residential installation. This equipment generates, uses, and can radiate radio frequency energy and, if not installed and used in accordance with the instructions, may cause harmful interference to radio communications. However, there is no guarantee that interference will not occur in a particular installation. If this equipment does cause harmful interference to radio or television reception, which can be determined by turning the equipment off and on, the user is encouraged to try to correct the interference by one or more of the following measures: 1) Reorient or relocate the receiving antenna. 2) Increase the separation between the equipment and receiver. 3) Connect the equipment to an outlet on a different circuit from the receiver. 4) Consult the dealer or an experienced radio/TV technician for help. Important: Changes or modification to this product not authorized by Tenka Inc. could void the electromagnetic compatibility (EMC) and wireless compliance and negate your authority to operate the product. This product has demonstrated EMC compliance under conditions that include the use of Tenka Inc. peripheral devices.

WARNING This product contains chemicals known to the State of California to cause cancer and birth defects (or other reproductive harm). **WARNING** Choking hazard — small

parts. Not for children under 3 years. **WARNING** This product contains small magnets. Swallowed magnets can stick together across intestines, causing serious injuries. Seek immediate medical attention if magnets are swallowed or inhaled. **WARNING** This toy is only intended for use by children over the age of 8 years.

APP Free app download. Ask parent's permission first. Apple and the Apple logo are trademarks of Apple Inc., registered in the U.S. and other countries. Apple Store is a service mark of Apple Inc. Google Play is a trademark of Google Inc.

CONTACT For help with your Circuit Cubes or other questions, please email: support@circuitcubes.com.

FCC ID: AUI-TBT01A





circuit
CUBES