

Screw layout : 8" on center on the vertical edges
12" on center at intermediate studs

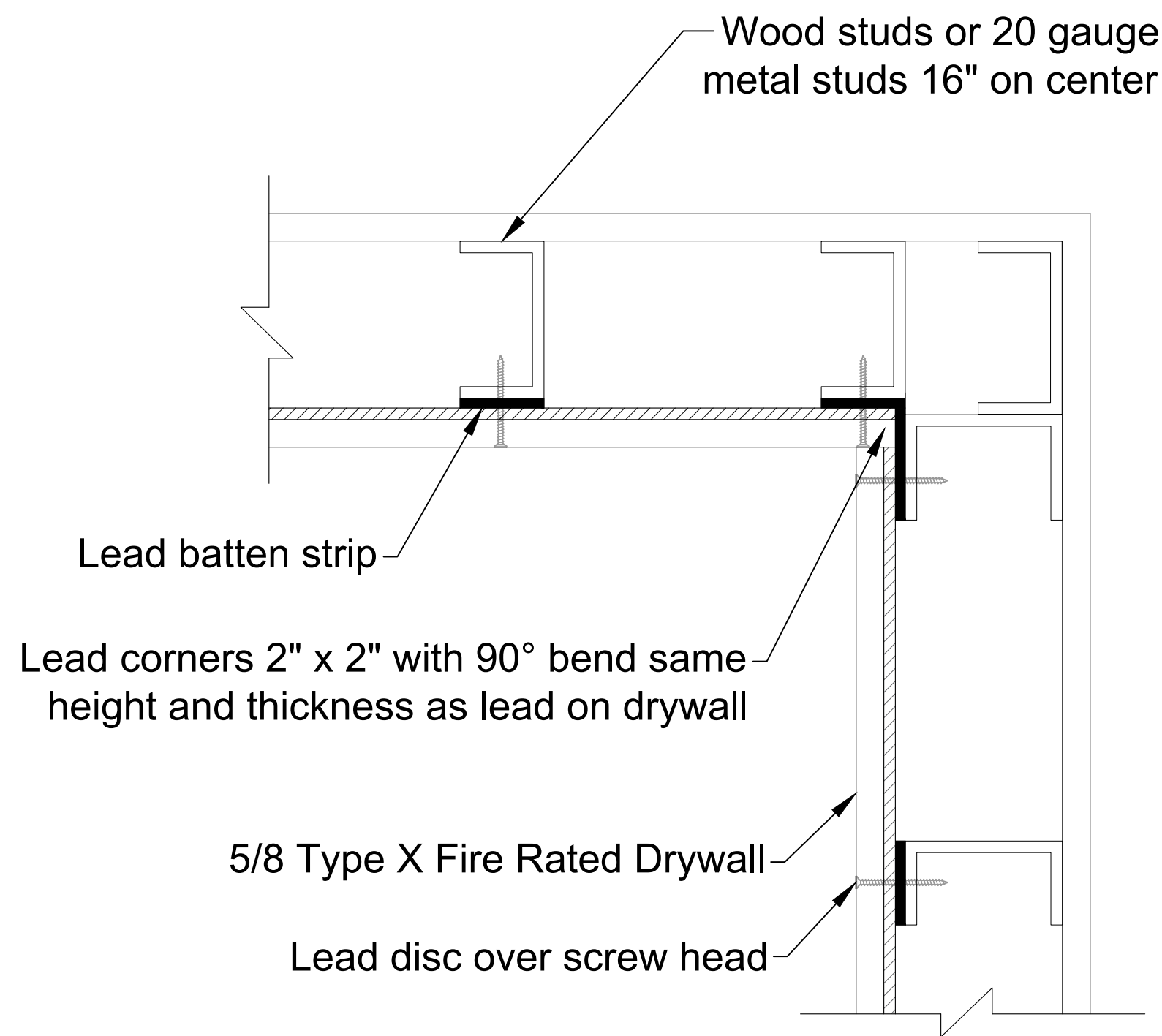

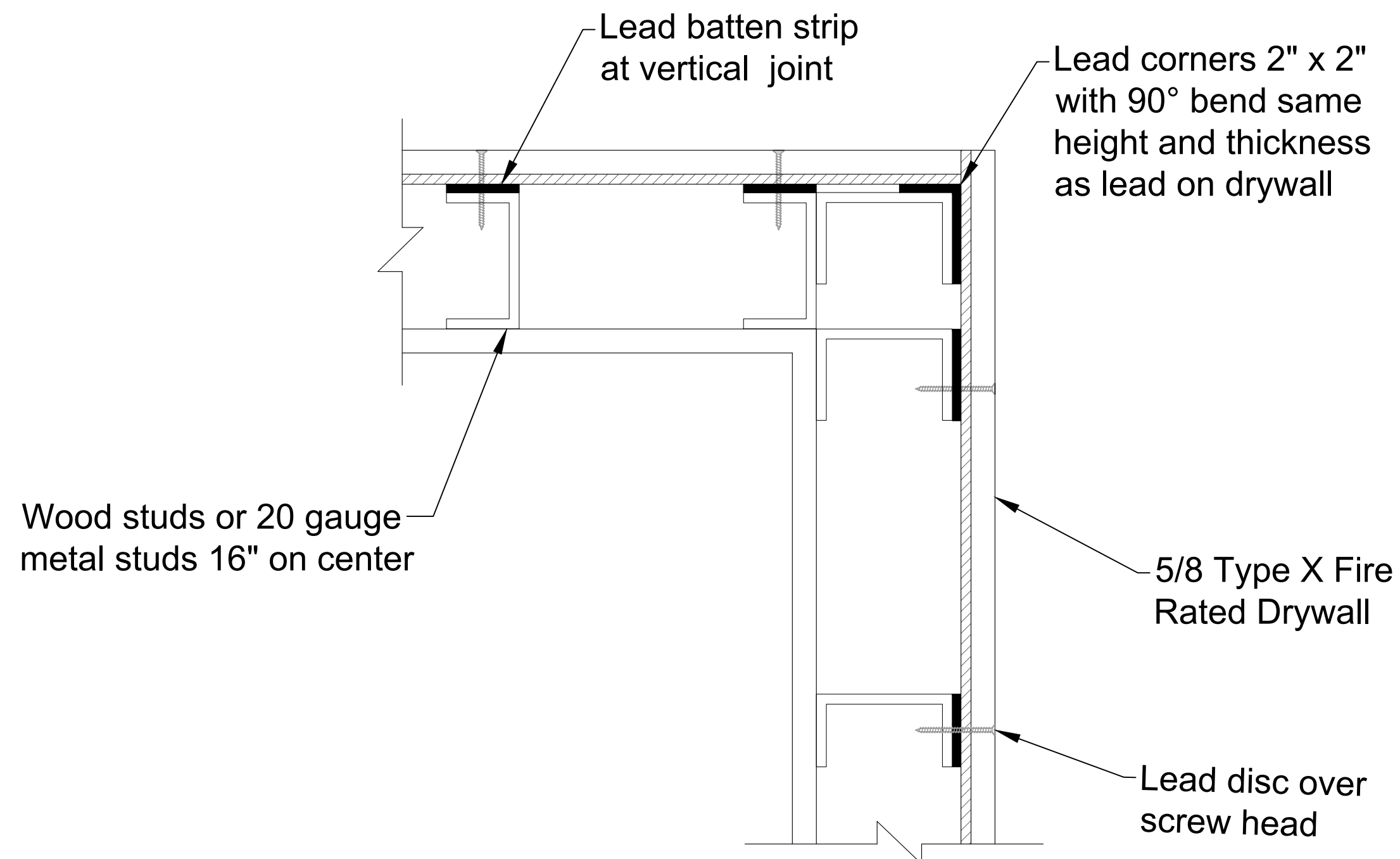

Lead Lined Wall Detail - Inside Corners



Lead Lined Wall Detail - Outside Corners



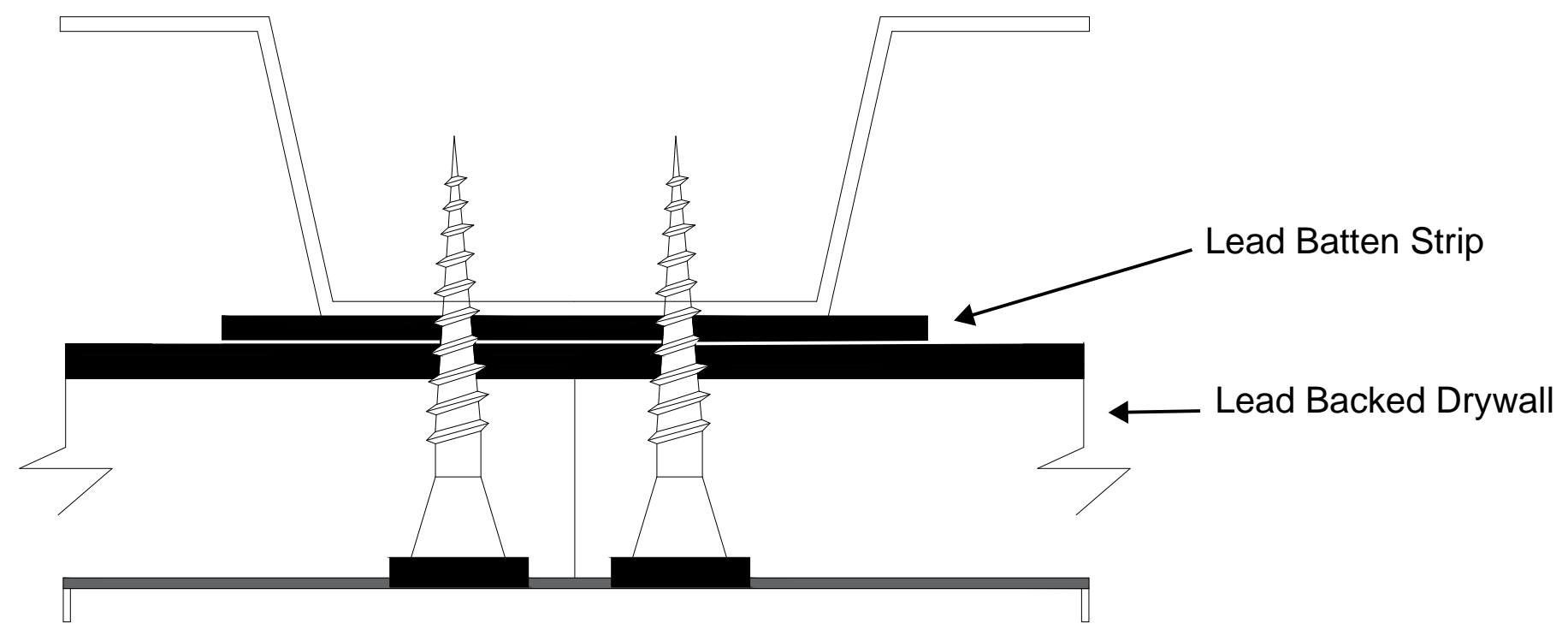

Lead batten strip at vertical joint
Lead discs cover screw heads

