



MAYTECH INNOVATIONS CO., LTD.

Phone: 0086-21-56165310 email: eileen@maytech.cn Web., www.maytech.cn

Maytech 300A Water-cooled & Waterproof ESC Ver.20231013

● Specs.

1. Watercooled & Waterproofed 2 versions available. Water-cooled version is splash water-proof, cannot be sinked in water. Water-proof version is IP68, can directly work in water.
2. Continuous current: 300A
3. Burst Current: 1000A
4. Working Voltage: 6-14S Lipocells
5. Weight: 680g
7. Programmable cable(2-core) : Brown-GND, Yellow- Prog Signal
8. Signal cable(2-core) : to connect receiver, eg. Maytech SKR1905WReceiver PWM-T pin

Water-cooled version, MTSF300A-OPTO

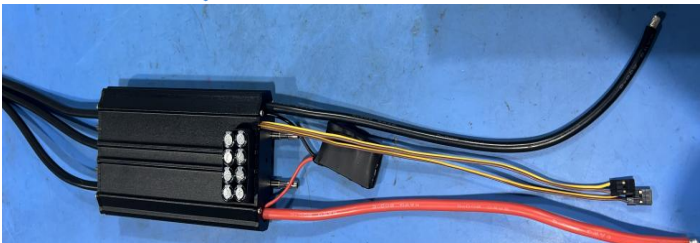

Water-proof version, MTSF300A-WP



● Wiring Instruction, signal and programmable cable

for water-cooled ESC MTSF300A-OPTO,

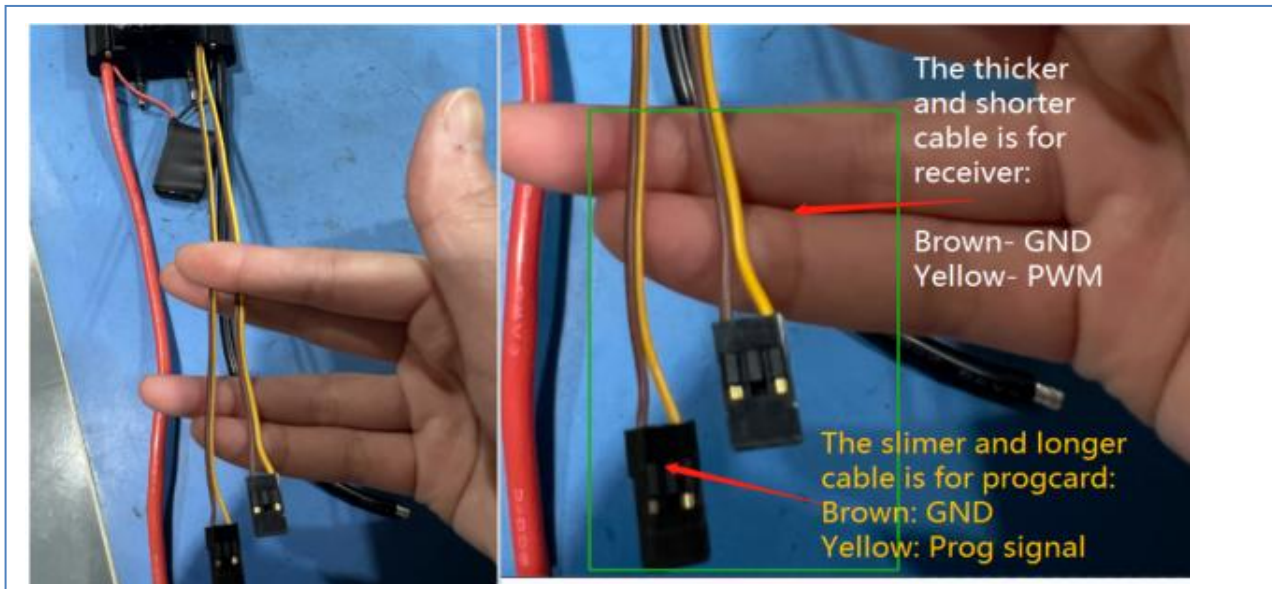



MAYTECH INNOVATIONS CO., LTD.

Phone: 0086-21-56165310 email: eileen@maytech.cn Web., www.maytech.cn

To connect MTSKR1905WF receiver :

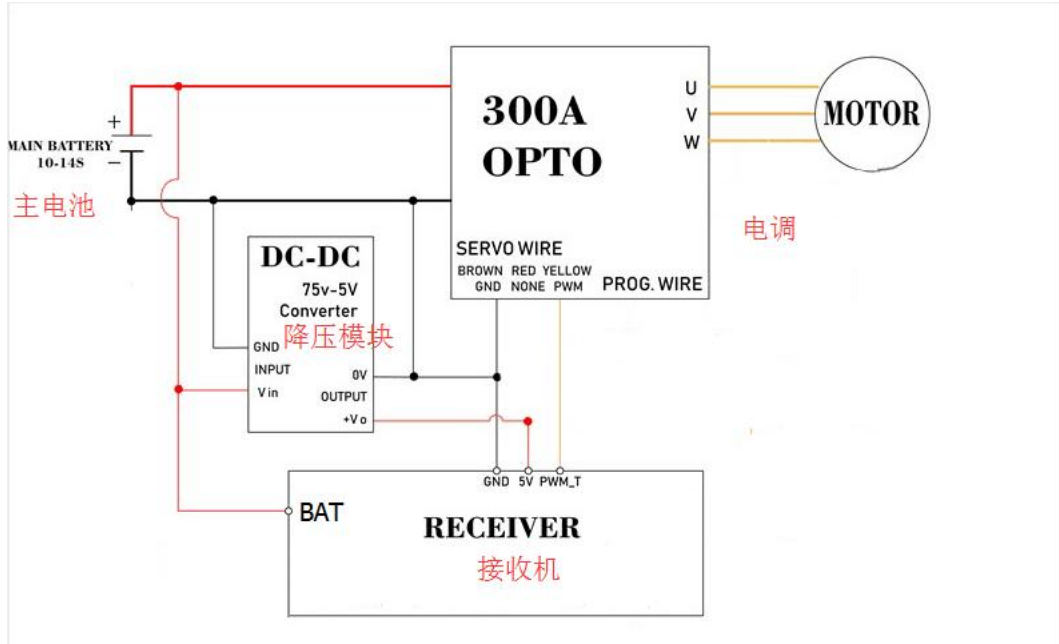

➔ for water-proof ESC MTSF300A-WP with Junction Box,

Connect to Motor

Connect to Battery
Red: +
Black: -

1 { PWM
5V
GND
For receiver signal

2 { Prog
5V
GND
For ESC Progcard

3 { 12V
GND
GND
5V
Built-in 5V/12V BEC output

4 { Safety
Switch
Throttle will turn off when connect the two pins.

When use with Maytech MTSKR1905WF Receiver, MT Receiver can be plugged directly to MR2 and MR3. MR1 is the lead-out Pins for MT Receiver built-in Mosfet Switch and Relay Switch. MR2 is the Relay Switch pins to connect MT Receiver. MR3 will connect MOT/BAT pins of MT Receiver and Remote will display motor RPM and Main Battery Voltage. And you don't need to use 1 (PWM/GND/5V).

<p>MR1 {</p> <ul style="list-style-type: none"> 20V 2A Transistor(mosfet) Switch -SWI Normally Open - OPE 30V 3A Relay Switch Common Point - COM Normally Close - CLO

LED 1/2/3 {

- 5V BEC
- 12V BEC
- Throttle signal

Please note:
If use other supplier's remote and receiver, MR1/2/3 pins don't work.



MAYTECH INNOVATIONS CO., LTD.

Phone: 0086-21-56165310 email: eileen@maytech.cn Web., www.maytech.cn

● Program settings via progcard-HA

1. Connect power supply to progcard

Pls give extra 5V power to the programmable cable, otherwise progcard screen will not turn on.

When you give 5V power to the programmable cable, progcard screen will turn on, then you can start to program.

If the screen shows dark and no words, it might be the signal cable is plugged in mistake direction, take off the programmable cable and plug in opposite direction. (Attention pls.: Do not connect progcard to computer, otherwise it will use computer for programming, not on progcard.)



2. Connect progcard to ESC

3. Program settings,

- Brake Type: (Brake OFF, Soft Brake, Mid Brake, Hard Brake).
- Battery Type: (LiPo, LiFe or NiCd/NiMh).
- Cut Off Voltage Threshold: (2.8V/50%, 3.0V/60%, 3.2V/65%, No Protection).
- Motor Timing: (Auto, 2°, 8°, 15°, 22°, 30°). Recommends setup 2° for electric surfboard customer.
- SBEC Voltage Output: 5.0V. Recommended setup 5.0V.
- Governor Mode: (RPM OFF, 1st Soft Start, 2nd Soft Start, 1st Governor Mode, 2nd Governor Mode) Recommended set up RPM OFF, because Maytech remote with cruise speed control.
- Motor rotation: (Forward/ Reverse).
- Start Up Strength: (10%, 15%, 20%, 25%, 30%, 35%, 40%, 45%, 50%). Recommended setting 30%.
- Low Voltage Cut off Type: (Reduce Power, Cut off Power). Recommended setup Reduce Power.

Values marker in red are default settings.

4. Program process,

4.1. Turn on the ESC power, pls make sure disconnect throttle (PWM signal), or you can't program even if progcard is



MAYTECH INNOVATIONS CO., LTD.

Phone: 0086-21-56165310 email: eileen@maytech.cn Web., www.maytech.cn

connected.

4.2. When program cable and 5V power are both connected, progcard screen will show “LCD Program Card”. Press “MENU” button, and then screen will show “L Ready to Connect ESC”, progcard is trying to connect with ESC.

4.3. It takes about 10 seconds for progcard and ESC connection, if successfully connected, screen will display parameter items and values, press “MENU” to switch different parameter items, press “VALUE” to switch item values, press “RESET” to set all item values default, press “OK” to save current value.

4.4. If screen shows “L Ready to Connect ESC” for over 10 seconds, it means the connection is failed, you need to check if the ESC throttle (PWM signal) is disconnected or not, if confirmed throttle signal is disconnected, disconnect program cable, and reconnect progcard, if still not working, turn off ESC power, and redo the above steps.

4.5. After programming, you need to turn off ESC and disconnect progcard, reconnect ESC power, then adjusted parameters can be effective.

4.6. Pls note! All 300A ESC Timing default value is 2 degree, but progcard Timing default value is Auto.

If you press “RESET”, progcard will reset ESC Timing to Auto, this change is not problem for motor smaller than MTI65mm series, if motor is larger than MTI65 series, please must manually change ESC Timing back to 2 degree.

4.7. Settings recommended for Maytech 85165 and 65162 motors. (pls do not change **Motor timing** and **Start up strength**) :

Brake Type: Brake Off

Battery type: Lipo

Cut Off voltage threshold: (3.0V/60%)

Motor timing: 2°

SBEC voltage output: 5.0V

Governor mode: RPM OFF

Start Up strength: 30%

Motor rotation: Forward

Low voltage cutoff type: Reduce Power.

The users manual will be updated along with further product improvements. Pls contact us if any question when you use our products. You can reach us by phone: 0086-21-56165310, or email to eileen@maytech.cn.