

**UPB™ Devices Transmitting Through a 3 Phase Repeater**

The UTR is used to respond to “Repeater” UPB™ messages received from a UPB™ device from one phase onto every phase of the powerline. To enable a UPB™ device to transmit through the UTR, use the **Edit Device** dialog and check the “Transmit through a powerline repeater” box in the **Transmission Options** of the **Advanced Tab**.

**LED Indicators**

The UTR 3-Phase Repeater has a two-color (red/green) LED indicator for each electrical phase and one to indicate the status of the UTR. These LED indicators normally appear orange (red and green on simultaneously) and will change different colors to indicate UPB™ communication status and configuration status as outlined in Table 1 and Table 2 below.

LED Color	UTR Status
Solid Red/Green	One or more phases detected and no UPB™ message on any of the AC Powerline phases
LED Off	AC Powerline not detected
Red	Receives a UPB™ message for the UTR
Blink Red/Green	Receives a UPB™ message for another device
Green	UTR is transmitting a UPB™ message

**Table 1: UTR Status LED Operation**

LED Color	Phase Status
Solid Red/Green	AC Powerline detected and no UPB™ message on the power line
LED Off	AC Powerline not detected
Red	Receives a valid UPB™ message
Green	UTR is transmitting a UPB™ message

**Table 2: Phase Status LED Operation**

**Specifications**

Model Number	UTR
Connections	16 GA
LED Indicators	4
Dimensions	6.5 X 4.34 X 1.83 in
Weight	1.5 lb.
Mounting	Mounting holes provided
Input Power	110-120 VAC
Input Frequency	60 Hz ± 5%
Operating Temp	-40 °F to 104 °F



**Three-Phase Repeater & Computer Interface (CIM) MODEL UTR**

**INSTALLATION & OPERATING INSTRUCTIONS**

**READ THESE INSTRUCTIONS BEFORE INSTALLING DEVICE**

The 3-Phase Repeater is intended for installation in accordance with the National Electrical Code and local regulations. It is recommended that a qualified electrician perform this installation. Retain these instructions for reference or download the manual from [www.simply-automated.com](http://www.simply-automated.com).

**IMPORTANT NOTES PRIOR TO INSTALLATION**

Simply-Automated Three-Phase Repeater, Model UTR requires a neutral (white) connection wire.

**CAUTION:** Before installing the UTR be sure that power has been disconnected by turning off the circuit breaker(s). Installing products while the power is on may expose you to dangerous voltages and may damage the device!

**About Your UTR 3-Phase Repeater**

The UTR 3-Phase Repeater (Figure 1) is specifically designed to repeat a UPB™ message onto each 120 V electrical phase of a standard 3 Phase AC powerline where the phases are separated by 120°. The UTR is capable of receiving a UPB™ message on one of the AC electrical phases and repeating it onto all three AC electrical phases. The UTR 3-Phase Repeater also provides a RS-232 serial interface that can be used to transmit and receive UPB™ messages from a host computer or home automation controller.

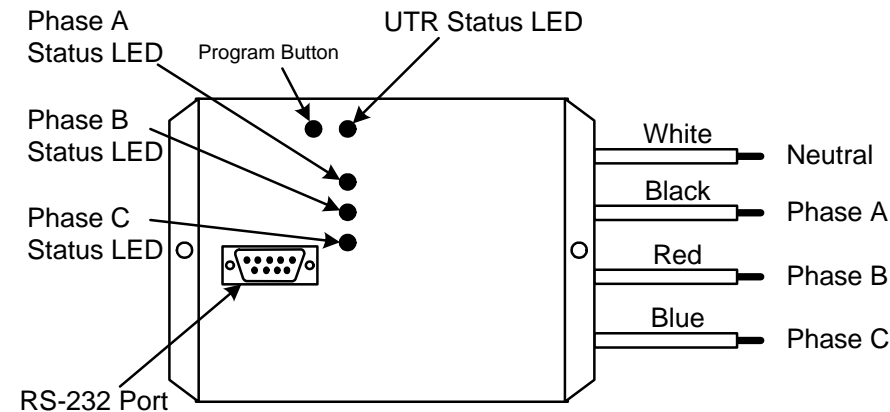

**Figure 1: UTR Three-Phase Repeater**

**Installation Instructions**

The Model UTR Three-Phase Repeater is wired directly to the main electrical panel. This section will illustrate how to hook-up the connections.

**Notes:**

1. Refer to Figure 1 and Figure 2 to determine the wire colors of the hook-up.
2. The UTR requires a neutral (white) connection.
3. All electrical phases are NOT required to be connected.

**Installation Procedure**

1. Turn circuit breaker(s) off for "Phase A", "Phase B", and "Phase C" circuits to be connected to the UTR.
  2. Connect the UTR 3-Phase Repeater to the following electrical wires (see Figure 2 for reference):
  3. Connect the "Neutral" wire to the WHITE wire coming out of the UTR (REQUIRED).
  4. Connect the "Phase A" wire to the BLACK wire coming out of the UTR (REQUIRED).
  5. Connect the "Phase B" wire to the RED wire coming out of the UTR (OPTIONAL).
  6. Connect the "Phase C" wire to the BLUE wire coming out of the UTR (OPTIONAL).
- Either Phase B or Phase C may be used when connecting 2 phases of a 3 phase system – as in a commercial, or multiple dwelling building with 3 phase power).
7. Make sure all wire connections are tight and that no bare copper is exposed.
  8. Restore power. Verify that the UTR Status LED indicator is solid orange (see Figure 1 for reference).
  9. Configure the UTR for desired operation (as explained in the "Configuring the UTR" section of this manual).

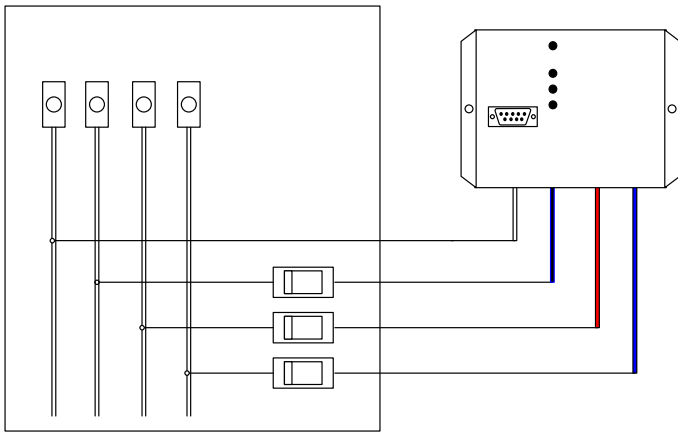

Figure 2: Wiring Diagram

**Using Your UTR 3-Phase Repeater**

The UTR 3-Phase Repeater is designed to work in a UPB™ lighting system consisting of Transceiver Switches/Dimmers and/or other UPB™ devices. The UTR 3-Phase Repeater can be used to repeat UPB™ messages received from one of these devices onto every phase of the powerline. UPB™ devices must be configured in UPStart to send Repeater messages. Open the **Edit Device** dialog and check the "Transmit through a powerline repeater" box in the **Transmission Options** of the **Advanced Tab**. Once the devices are configured they transmit Repeater messages that the UTR transmits on all phases.

The UTR may be used as a Computer Interface Module (CIM) to configure all UPB devices or the plug-in CIM (UMC-DB9-W) can be used to configure devices one phase at a time. The plug-in CIM will only communicate to devices on the same phase in a 3 phase system.

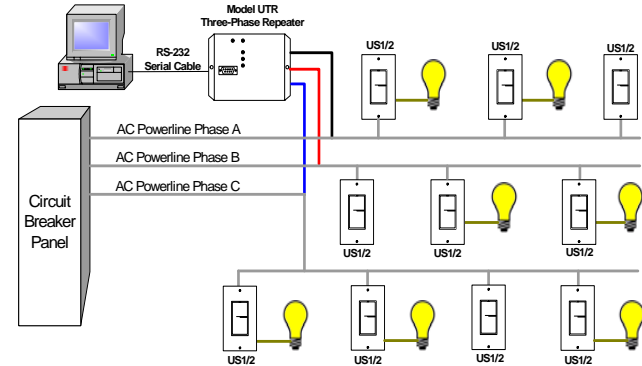

Figure 3: Repeater System Diagram

**Using the UTR 3 Phase Repeater with UPStart**

The UPStart UPB™ Configuration Software is designed to interface to the powerline through the UTR. Once your UTR is properly connected to the powerline and your computer, you can enable UPStart to use the UTR as a CIM (Computer Interface Module) by using the UPB™ Interface Device Setup Dialog. Follow the steps described below to enable UPStart to use your UTR as a powerline interface:

**Step 1: Specify the UPB™ Interface and Communications Port**

Select the **Tools**→**UPB™ Interface Device**→**Select** menu item to open the UPB™ Interface Device Setup Dialog. In the UPB™ Interface Setup dialog specify the "3-Phase Powerline Interface" and the communications port (i.e. Comm 1, Comm 2) to which your UTR is connected.

**Step 2: Establish UTR Communications Interface**

Press the **Connect** button in UPStart to test the communication between UPStart and the UTR. If communications is operational then UPStart will display information about the UTR interface including the UTR firmware version.

**Step 3: Repeater Transmission Count**

The Repeater Transmission Count may be modified so that the UTR repeats a UPB™ packet 1, 2, 3, or 4 times. The default Repeater Transmission count is 2. The UPB™ Repeater Transmission Count may be modified by selecting the **Settings** button in the UPB™ Interface Device Setup Dialog of UPStart once communication with the UTR has been established (Step 2 above).

**Step 4: Set the UPB™ Network(s) for the repeat function**

The default setting for the UTR is to respond to every "Repeater" message it receives. The UTR may be configured to respond to "Repeater" messages only from specified UPB™ Networks. One to eight UPB™ Networks may be specified. Select the **Settings** button in the UPB™ Interface Device Setup Dialog of UPStart once communication with the UTR has been established (Step 2 above). Click on the check box to enter a UPB™ Network ID for which the repeat function is desired. This is useful to reduce possible interference and unwanted device control in multiple dwelling or office buildings.

**Step 5: Close the UPB™ Interface Setup Dialog**

Close the UPB™ Interface Setup dialog by pressing the **OK** button.

**Communication Modes**

The UTR has two operating modes: MESSAGE mode and PULSE mode. The last-used operational mode is retained during power interruption. UPStart software automatically sets the interface to PULSE mode operation, but most controllers require MESSAGE mode. To restore MESSAGE mode operation...

1. Place the UTR in SETUP mode by pressing the Program Button (located just left of the indicator) five times rapidly. The indicator will continuously blink GREEN.
2. Reset to MESSAGE mode by pressing the Program Button ten times. The indicator will continuously blink RED.
3. Press the Program Button once to exit SETUP mode.

Use a standard serial cable with a male DB9 connector for the UTR end (no cable is provided; the UTR uses the same cable as the one included with the UMC-DB9-W).