

## T6 Pro Z-Wave Programmable Thermostat User Guide



*\*TH6320ZW2003 depicted. Other models may vary.  
Actual size 4.09" x 4.09" x 1.06"*



## Welcome

This user guide is designed to help you get acquainted with your new T6 Pro Z-Wave thermostat. Check out the table of contents on page 2 to browse by topic.

## Need help? Get in touch.

**Web:** [yourhome.honeywell.com/](http://yourhome.honeywell.com/)

**Phone:** 1-800-468-1502

**Social:** Twitter: @HoneywellHome, Facebook: Honeywell Home



33-00296EFS-01

# Table of contents

<b>Thermostat features</b> .....	<b>3</b>
<b>Thermostat overview</b> .....	<b>4</b>
<b>Basic thermostat operation</b>	
Adjusting the temperature .....	4
Program schedule overrides.....	5
Adjusting the temperature in Auto mode .....	6
Selecting system mode.....	7
Built-in compressor protection .....	8
Setting the fan .....	8
<b>Main menu settings</b>	
Z-Wave setup.....	9
Z-Wave connection status.....	10
Main menu overview.....	11
Scheduling options .....	12
Setting a schedule.....	13
Reset schedule .....	14
Screen lock settings.....	14
Adjusting backlight brightness .....	15
Enabling/disabling Adaptive Intelligent Recovery.....	15
Setting the time and date.....	16
Cleaning the thermostat screen.....	16
Choosing Fahrenheit or Celsius .....	17
Viewing equipment status .....	17
Viewing thermostat information.....	18
Battery replacement.....	19
<b>Alerts and maintenance reminders</b> .....	<b>20</b>
<b>Appendices</b>	
Troubleshooting.....	22
5-year warranty.....	23
General system information .....	24
Regulatory information .....	24

# Thermostat features

The Honeywell T6 Pro Z-Wave Programmable Thermostat is a Z-Wave Plus certified thermostat designed to work with any Z-Wave compliant controller or gateway for easy programming and automation to deliver energy savings and comfort at the same time. When integrated with the app that controls your Z-Wave controller, it lets you program and control your home's HVAC system as well as control other Z-Wave devices connected to the same Z-Wave controller.

**Smart Scheduling:** You can choose whether you want the thermostat to follow just Home/Away temperature triggered by your Z-Wave controller or if home, whether you want to differentiate between Home/Sleep temperature.

The T6 Pro Z-Wave thermostat can also work as regular programmable thermostat when disconnected from your Z-Wave network. You can program a schedule where every day is different or a schedule where weekdays and weekends are different with four periods per day.

**Displays ambient air temperature, % relative indoor humidity and reports HVAC system status:** You can display actual temperature or % relative humidity, or to see whether your cooling / heating system is running.



**Auto change from heat to cool:** When Auto mode is selected, the T6 Pro Z-Wave thermostat can automatically determine whether your home needs heating or cooling to reach the desired temperature at the right time.



**Smart Alerts:** The T6 Pro Z-Wave thermostat can alert you when your HVAC system is not working properly and can remind you for things like when to change your furnace filter.



**Adaptive Intelligent Recovery:** The T6 Pro Z-Wave thermostat learns your heating and cooling cycle times to make sure the system delivers the temperature you want, when you want it.

# Thermostat overview

## Desired temperature

Shows desired indoor temperature.

## Indoor Temperature/ % Relative Indoor Humidity

Touch to display either the current indoor temperature or current % relative indoor humidity.

## Adjust temperature

Touch **+** or **-** to set your desired temperature.

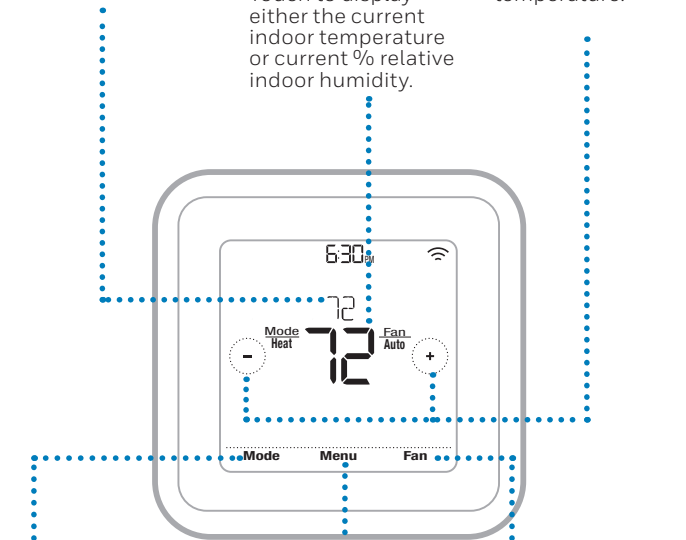

## Mode

Touch to select system mode:

- Auto (if enabled)
- Heat
- Cool
- Off
- Em Heat (Emergency Heat)

## Menu

Touch to program a schedule and see other customizable options.

## Fan

Touch to select fan mode:

- Auto
- On
- Circulate

# Adjusting the temperature

To adjust the desired temperature up or down, touch **+** or **-** on the thermostat home screen.

How long the change will be held depends on whether your thermostat is included or excluded in Z-Wave network and what schedule type is selected.

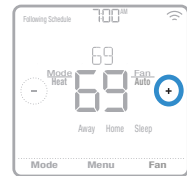

# Program schedule overrides

If the thermostat is included in Z-Wave network it typically follows the setting on your Z-Wave controller. If you adjust the temperature setpoint, it overrides the current setpoint until away state or new temperature setpoint is received from Z-Wave controller. Setting of Hold until time and Permanent hold (see below) will not be available on the thermostat screen.

If the thermostat is not included in the Z-Wave network and the thermostat is following time based schedule, you can set what time the new temperature setpoint will be held until or you can hold the new setpoint permanently.

There are several scheduling options available for the thermostat. For more information go to page 12.

## Program schedule override (temporary)

- 1 Touch **+** or **-** on the thermostat home screen to set your desired temperature. Hold **Hold Until** will appear together with the time the hold will end.
- 2 To change when the hold will end, touch the time and wait until the time starts blinking. Then, touch **+** or **-** to set when you want the hold to end. Touch **Hold Until** once more to confirm changes and return to the home screen.

After the hold period ends, the thermostat will automatically return to the program schedule. If you want to cancel the hold, touch **Hold Until** and then touch **Run Schedule**.

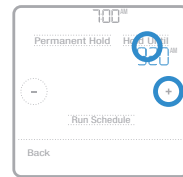
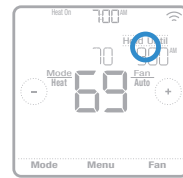

## Program schedule override (permanent)

- 1 Touch **+** or **-** on the thermostat home screen to reach your desired temperature. **Hold Until** will appear together with the time you want the hold to end.
- 2 Touch **Hold Until**. Permanent Hold will appear on screen. Touch **Permanent Hold** to hold this temperature until you manually change it.

To end permanent hold and return to the program schedule, touch **Permanent Hold** and then touch **Run Schedule**.

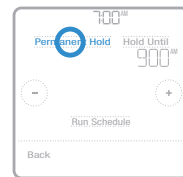
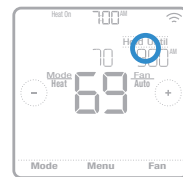

# Adjusting the temperature in Auto mode

Auto mode (when the thermostat automatically chooses heating or cooling to reach your desired temperature) is disabled by default. If your heating or cooling professional enabled it, you'll see Auto appear as an option under Mode on the thermostat home screen.

To choose your preferred temperatures for both heating and cooling in Auto mode, follow the steps below.

- 1 Touch **Mode** on the thermostat home screen until Auto appears. Then touch **+** or **-** to choose your preferred temperature for the mode that's currently active (heating or cooling).
- 2 Next, touch the text area where the active mode is displayed to switch to the inactive mode.
- 3 Touch **+** or **-** to choose your preferred temperature in the other mode. After 5 seconds of inactivity, your setting will take effect, and the thermostat screen will show the set point of the active mode.

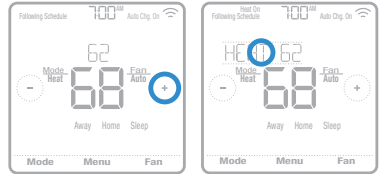

# Selecting system mode

Current system mode (Heat, Cool, Off, Em Heat) is displayed to the left of current indoor temperature on the thermostat home screen.

The mode that's currently running (Heat On, Cool On, Em Heat On) is displayed in the upper-left corner of the thermostat home screen.

To cycle through the available modes, touch **Mode** on the thermostat home screen and select the appropriate mode for your desired temperature.

- **Heat:** Controls the heating system.
- **Cool:** Controls the cooling system.
- **Off:** Turns the heating and cooling systems off.
- **Auto:** When enabled, the thermostat will automatically use heating or cooling to reach the desired temperature.
- **Em Heat:** Controls auxiliary or emergency heat; only available on systems with a heat pump.

## Notes:

- Em Heat and Auto modes may not appear on the thermostat screen depending on your equipment and how your thermostat was installed.
- Em Heat is only available for heat pump systems. The thermostat must also be configured to control a heat pump and an auxiliary/emergency heat stage.
- When Auto mode is selected, Auto Chg. On will appear in the upper-right corner of the thermostat home screen, and the active mode (Heat or Cool) will display under Mode. To set your temperature preferences in Auto mode, see page 6.



# Built-in compressor protection

If the compressor is restarted too soon after a shutdown, system damage can occur. The built-in compressor protection feature forces the compressor to wait a few minutes before restarting, helping to prevent damage to the heating or cooling system.

During the brief wait period, the thermostat will flash Cool On (or Heat On if you have a heat pump) until the wait period is over, at which point the compressor will turn back on.

**Note:** The flashing Cool On or Heat On message is also used for startup delay protection if AC power loss occurs.



# Setting the fan

Touch **Fan** on the thermostat home screen to cycle through available fan modes until the desired mode is displayed. Your changes will save automatically.

Available fan modes:

- **On:** The fan will run continuously.
- **Auto:** The fan will run only when the heating or cooling system is on.
- **Circ:** The fan will run at random intervals at least 35% of the time to keep air circulating throughout your home.





# Z-Wave setup

To include or exclude the thermostat from Z-Wave network, go to thermostat **MENU/Z-WAVE SETUP**.

- Touch **Select**. You will be asked to set your primary controller to **INCLUDE MODE**. Please refer to the user manual of your Z-Wave controller.
- After inclusion procedure has been initiated on your Z-Wave controller, touch **Select** on the thermostat.
- If the inclusion procedure is successful, **"INCLUDED"**, the node ID, and the Z-Wave connected status icon appear on the screen. If the procedure fails, **"FAILED TO INCLUDE"** appears on the screen.
- Your controller will indicate whether the thermostat was successfully added to its network. (Please refer to the user manual of your Z-Wave controller.)



## NOTES:

- Before adding the thermostat to a Z-Wave network, check that it does not already belong to one. If the thermostat is included in Z-Wave network, it offers to exclude. If the thermostat is excluded from Z-Wave network, it offers to include. You can also check the status by viewing the **Node ID** located in the thermostat **MENU/DEVICE INFO**. An excluded thermostat should show zero for the Node ID (000).
- Whether you are including or excluding thermostat from your Z-Wave network, first you have to initiate it on your Z-Wave controller. Please refer to the user manual of your Z-Wave controller.
- For other specific tasks, such as adding the thermostat to home automation scenes or groups, refer to the Z-Wave controller instructions.
- The T6 Pro Z-Wave thermostat works in the optional Z-Wave battery mode or normal power mode based on its power source. The Z-Wave power mode can only be changed when thermostat is **NOT** included in Z-Wave network. You can check the power mode in the thermostat menu under **MENU/DEVICE INFO**.
- If 24 VAC power source is not used or available, the thermostat must be powered by batteries. The thermostat will operate in LSS mode (power-save, sleep mode) to help conserve battery life after it has been included in a Z-Wave network. The Z-Wave radio supports beaming. It allows other devices in the network to wake up the Z-Wave thermostat, accept commands, and then go back to sleep.
- If you need the thermostat to operate AOS mode (always listening mode) to act as signal repeater and to increase network reliability, you need to ask your professional installer to power the thermostat by 24 VAC.

# Z-Wave connection status

Z-Wave connection status is located in the upper-right corner of the screen.



- Thermostat is included and connected to a Z-Wave network.
- Thermostat is excluded from a Z-Wave network.
- Thermostat is either included in a Z-Wave network but the Z-Wave signal is lost, or is included but AC power is lost (battery used as backup). In this case, Z-Wave radio is turned off to preserve battery life. AC power must be restored or you have to change the power mode. It can be done via excluding thermostat from Z-Wave network and including again in battery power mode where batteries are used as main power source. You can check the actual power mode in the thermostat

## **MENU/DEVICE INFO.**



*Example of thermostat included and connected in a Z-Wave network.*

# Main menu overview

Touch **Menu** on the thermostat screen and then use the  or  arrows to page through the following options.

## *SCHEDULE*

Create and edit a schedule for your thermostat to follow. (Available to edit only if time based schedule or smart schedule is configured.)

## *AWAY SETTING*

Set energy saving temperature setpoints for when you are away. (Available if thermostat is included in Z-Wave network.)

## *SCREEN LOCK*

Lock the screen to limit access to thermostat settings.

## *Z-WAVE SETUP*

Include or exclude the thermostat from Z-Wave network.

## *BRIGHTNESS*

Set the brightness of an inactive backlight. (Available if the thermostat is powered by 24 VAC.)

## *RECOVERY*

Enable or disable the Adaptive Intelligent Recovery feature.

## *CLOCK / DATE*

Manually set the clock, clock format and daylight saving time in the **CLOCK** sub-menu, and date in the **DATE** sub-menu.

## *CLEAN SCREEN*

Disable the touchscreen for 30 seconds so you can clean it.

## *TEMP SCALE*

Choose Fahrenheit or Celsius.

## *RESET*

**Schedule:** Resets to the default Monday-Friday, Saturday-Sunday schedule.

## *EQMP STATUS*

View current status of your heating or cooling equipment.

## *DEVICE INFO*

View your thermostat's device information, such as Z-Wave power mode, Z-Wave node, home ID, and model number.

## *ALERTS*

View, snooze or dismiss active alerts and reminders (available only when you see the active alert symbol  on the thermostat home screen).

## Navigating the menus

**Menu:** Touch to access all options and sub-menus.

 or : Touch to page through options and sub-menus.

 or : Touch to adjust things such as temperature, time and date.

**Back** or **Cancel:** Touch to discard changes or go back to the previous menu.

**Select:** Touch to access a sub-menu.

**Done:** Touch to confirm selection.

**Tip:** You can touch **Select** to access a sub-menu, or you can touch the text in the message area (the word SCHEDULE, for example).

# Scheduling options

The T6 Pro Z-Wave thermostat offers flexible scheduling. The options available differ depending on whether the thermostat is included/excluded from Z-Wave network.

- |                              |                                   |
|------------------------------|-----------------------------------|
| <b>1 No schedule</b>         | <b>3 Occupancy based schedule</b> |
| <b>2 Time based schedule</b> | <b>4 Smart schedule</b>           |

## If the thermostat is not included in Z-Wave network:

The thermostat can be set as non-programmable (1), or you can program and follow a Time based schedule (2) based on the time of day or day of the week.

The default program schedule is 5-2 (Mon-Fri; Sat-Sun), with different settings for weekdays and weekends, four time periods per day. See the table below for the default settings, which have adjustable periods and temperature setpoints.

Time based schedule:					
Period	Start Time	Heat (Mon-Fri)	Cool (Mon-Fri)	Heat (Sat-Sun)	Cool (Sat-Sun)
Wake	6:00 AM	70 °	78 °	70 °	78 °
Away	8:00 AM	62 °	85 °	62 °	85 °
Home	6:00 PM	70 °	78 °	70 °	78 °
Sleep	10:00 PM	62 °	85 °	62 °	85 °

## If the thermostat is included in Z-Wave network:

It typically follows the settings of your Z-Wave controller. When not in Away mode, it can either follow your Home temperature setpoint based on occupancy states (Home/Away) sent by Z-Wave controller (3) or it can even differentiate between Home and Sleep temperature setpoints according to actual time period (4).

The default program schedule is the Smart schedule, 5-2 (Mon-Fri; Sat-Sun), with different settings for weekdays and weekends. See the table below for the default settings, which have adjustable periods and temperature setpoints.

Smart Schedule:					
Period	Start Time	Heat (Mon-Fri)	Cool (Mon-Fri)	Heat (Sat-Sun)	Cool (Sat-Sun)
Away	N/A*	62 °	85 °	62 °	85 °
Home	6:00 AM	70 °	78 °	70 °	78 °
Sleep	10:00 PM	62 °	85 °	62 °	85 °

To turn the Smart schedule off and to use just Occupancy based schedule (Home/Away temperature setpoints only) go to thermostat **MENU/SCHEDULE** and turn the Time based schedule off. See table below with default, adjustable temperature setpoints.

Occupancy based schedule:			
Period	Start Time	Heat	Cool
Away	N/A*	62 °	85 °
Home	N/A*	72 °	78 °

\*Triggered by Z-Wave controller



## NOTES (for when the thermostat is INCLUDED in Z-Wave network):

- Away mode is an Energy saving setback mode triggered by Z-Wave controller or gateway.
- Away setpoint is adjustable and common for all days, configurable in the thermostat **MENU/AWAY SETTING**.
- Home setpoint in the Occupancy based schedule is temperature setpoint adjustable on the thermostat Home screen. Common for all days.
- Home and Sleep setpoints in the Smart schedule are configurable in the thermostat **MENU/SCHEDULE**.

## Schedule status

Active Time based schedule or Smart schedule is indicated by "Following Schedule" text in top left corner of the thermostat screen.

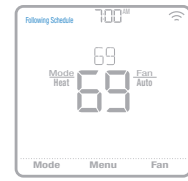

## Schedule period

Shows current schedule period.

- Time-based schedule: Wake, Away, Home or Sleep.
- Smart schedule: Away, Home or Sleep.
- Occupancy based schedule: Away or Home.
- No schedule: Schedule periods are not displayed



## Setting a schedule

To edit a schedule on the thermostat screen, follow the steps below.

- 1 Touch **Menu** on the thermostat home screen.
- 2 Touch the ⏪ or ⏩ arrows until you see SCHEDULE, then touch **Select**.
- 3 Touch the ⏪ or ⏩ arrows to select a period in a day or set of days, then touch **Select** on the period you want to edit.
- 4 Touch the time area, then touch + or - to adjust when the period starts. Touch **Select** to confirm.
- 5 Touch the temperature area, then touch + or - to adjust your preferred temperature for the mode that's currently active (either heating or cooling). Touch **Select** to confirm. Then touch + or - to adjust your preferred temperature for the inactive mode. Touch **Select** to confirm.
- 6 Edit the next period or use the ⏩ until you see **DONE**, then press **Select** to save changes and go to the home screen.

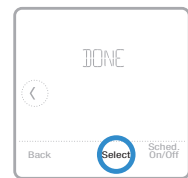
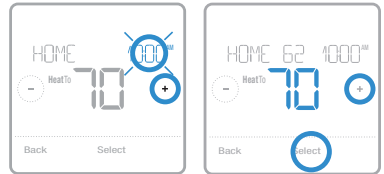
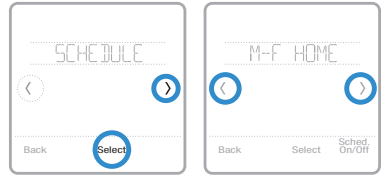

### NOTES:

- Schedule menu is available only if time based schedule or smart schedule is configured.
- If not connected to Z-Wave network, Away setpoint is programmable for each day or group of days in **MENU/SCHEDULE**.
- If connected to Z-Wave network, Away setpoint is a common for all days, programmable in **MENU/AWAY SETTING**.

# Reset schedule

To reset your schedule back to the default temperature setpoints (see page 12), follow steps below.

- 1 Touch **Menu** on the thermostat screen.
- 2 Touch the ◀ or ▶ arrows until you see RESET, then touch **Select**.
- 3 Touch the ◀ or ▶ arrows until you see SCHEDULE, then touch **Select**.
- 4 Touch **Yes** to confirm.

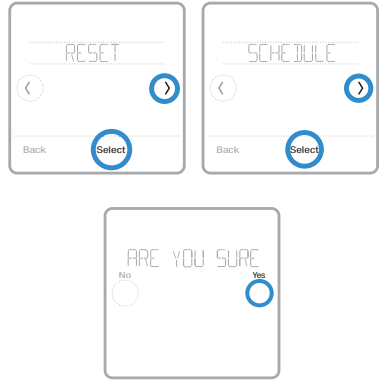

# Screen lock settings

To prevent unauthorized access to the thermostat, or to limit changes to the system settings, there are two screen lock settings you can apply.

- **Partial lock:** Only the temperature can be changed.
- **Full lock:** No access is allowed without a PIN number.

## Applying a screen lock setting

- 1 Touch **Menu** on the thermostat home screen.
- 2 Touch the ◀ or ▶ arrows until you see SCREEN LOCK, then touch **Select**.
- 3 Touch the ◀ or ▶ arrows to select your desired screen lock setting, then touch **Select**.
- 4 A PIN number will appear on screen. Write it down and keep it in a safe place.
- 5 Touch **Select**, and confirm your screen lock setting by touching **Yes**.

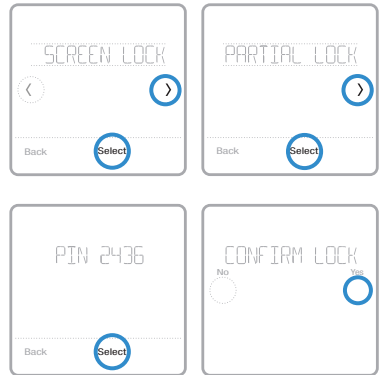

A partially or fully locked screen will be indicated by a lock symbol at the bottom of the thermostat screen.

## Unlocking the screen

- 1 Touch the lock symbol  on the thermostat home screen.
- 2 When prompted to enter a PIN number, touch + or - to select the first number of the PIN code. Touch Select to confirm, and repeat for the remaining numbers.

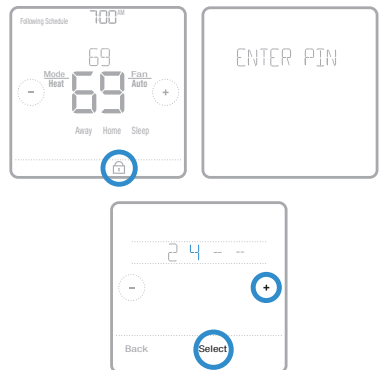

When you enter the correct PIN, you'll return to the thermostat home screen. To re-lock the screen after you're done making changes, follow the steps above to apply a lock setting.

# Adjusting backlight brightness

When the thermostat is in idle mode, you can adjust how bright you'd like the screen. You can choose a brightness level from 00 (display backlight is off, which is the default) up to 05 (maximum brightness). To adjust backlight brightness, follow the steps below.

- 1 Touch **Menu** on the thermostat home screen.
- 2 Touch the ◀ or ▶ arrows until you see BRIGHTNESS, then touch **Select**.
- 3 Touch + or - to adjust the brightness level, which will change immediately.
- 4 Touch **Done** to confirm.

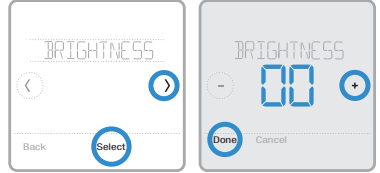

**NOTE:** This setting is only available if thermostat is powered by 24 VAC. This setting only applies to times when thermostat is not touched. When adjusting settings thermostat is always at full brightness.

# Enabling/disabling Adaptive Intelligent Recovery

Over time, your T6 Pro Z-Wave thermostat will learn how long it takes your system to reach the desired temperature. It can then turn on your heating or cooling equipment at the right time to make sure your home is comfortable by the time you expect. This feature is enabled by default. To disable it, follow the steps below.

- 1 Touch **Menu** on the thermostat home screen.
- 2 Touch the ◀ or ▶ arrows until you see RECOVERY, then touch **Select**.
- 3 Touch the ◀ or ▶ arrows to select RECOVERY ON or RECOVERY OFF, then touch **Done** to confirm.

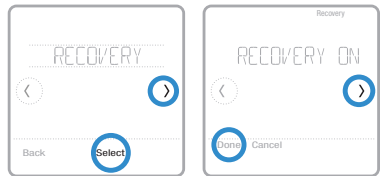

When Adaptive Intelligent Recovery is active, you'll see the recovery symbol in the upper-right corner of the thermostat screen.



# Setting the time and date

## Setting the time

- 1 Touch **Menu** on the thermostat home screen.
- 2 Touch the ◀ or ▶ arrows until you see **CLOCK**, then touch **Select**.
- 3 Touch the ◀ or ▶ arrows until you see **SET TIME**, then touch **Select**.
- 4 Press + or - to set the time (or press and hold the buttons to move more quickly). Touch **Done** when finished.
- 5 Set clock format (12 hours or 24 hours) and daylight saving time in the same **CLOCK** sub-menu.

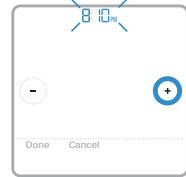

## Setting the date

- 1 Touch **Menu** on the thermostat home screen.
- 2 Touch the ◀ or ▶ arrows until you see **DATE**, then touch **Select**.
- 3 Touch + or - to set the month, then touch **Select** to confirm.
- 4 Continue to set day and year in the same way. Touch **Select** to save your changes.

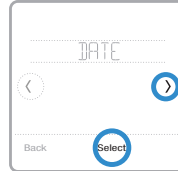

# Cleaning the thermostat screen

With the clean screen option, you can lock the thermostat screen so you don't accidentally change your settings when you clean. Follow the steps below to activate clean screen mode.

- 1 Touch **Menu** on the thermostat home screen.
- 2 Touch the ◀ or ▶ arrows until you see **CLEAN SCREEN**, then touch **Select**.

The screen will deactivate for 30 seconds. A countdown timer will display the amount of time until screen reactivation.

**Tip:** To clean the thermostat screen, spray water or household cleaner onto a cloth, then use the cloth to clean the screen. Avoid abrasive cleaners and do NOT spray liquid directly on the thermostat.

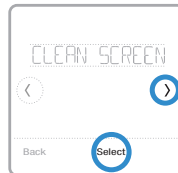



# Choosing Fahrenheit or Celsius

To select a temperature scale, follow the steps below.

- 1 Touch **Menu** on the thermostat home screen.
- 2 Touch the ◀ or ▶ arrows until you see TEMP SCALE, then touch **Select**.
- 3 Touch the ◀ or ▶ arrows to select FAHRENHEIT or CELSIUS then touch **Done** to save your changes.
- 4 Touch **Back** to return to the thermostat home screen.

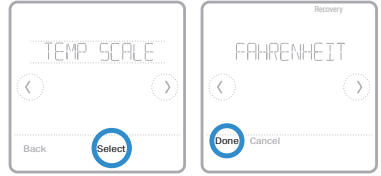

# Viewing equipment status

You can check the status of your heating or cooling equipment and fan by following the steps below. Please note that system data may vary depending on thermostat model and how the thermostat was installed.

- 1 Touch **Menu** on the thermostat home screen.
- 2 Touch the ◀ or ▶ arrows until you see EQMT STATUS, then touch **Select**.
- 3 Touch the ◀ or ▶ arrows to select which system you want status information on.

After 3 seconds, system status information will scroll on the screen.

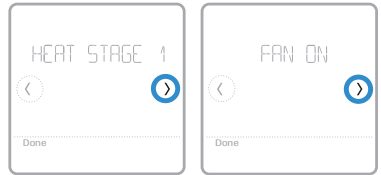
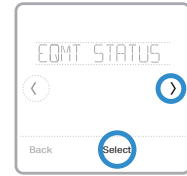

# Viewing thermostat information

To see your thermostat's technical information, follow the steps below.

- 1 Touch **Menu** on the thermostat home screen.
- 2 Touch the ◀ or ▶ arrows until you see **DEVICE INFO**, then touch **Select**.
- 3 Touch the ◀ or ▶ arrows to view information such as:
  - Model Number
  - Power Mode
  - Z-Wave Node ID
  - Z-Wave Home ID
  - Serial Number
  - Date code
  - Firmware version
  - Z-Wave Firmware version
  - Z-Wave library

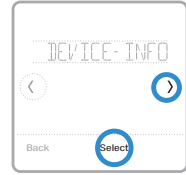

# Battery replacement

Batteries are optional (to provide backup power) if your thermostat was wired to run on 24 VAC power when installed. If your thermostat was wired to run on 24 VAC power, then batteries are NOT required.

Install fresh batteries immediately when the low battery alert appears. The alert appears about two months before the batteries are depleted.

Even if the low battery alert does not appear, you should replace batteries once a year, or before leaving home for more than a month.

If batteries are inserted within two minutes, the time and day will not have to be reset. All other settings are permanently stored in memory, and do not require battery power.

## NOTES:

- When replacing batteries, alkaline batteries are recommended.
- When the battery power is low, the thermostat's backlight is disabled to save battery power.
- When battery power is critically low, only the alert icon and the battery icon are displayed, and the thermostat cannot control your HVAC system. Batteries must be replaced immediately.



When the low battery alert appears, press gently to loosen the thermostat and then carefully pull it from the wall mount.

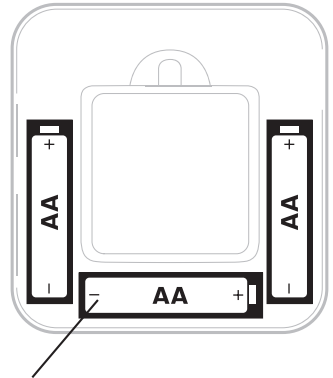
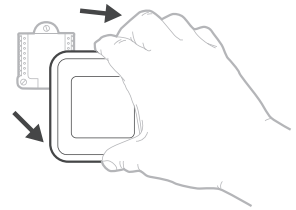

Insert fresh alkaline AA batteries and reinstall thermostat. Match the polarity of the batteries with the + / - marks inside the battery compartment.

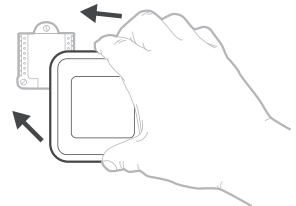



# Alerts and maintenance reminders

The T6 Pro Z-Wave thermostat comes with a set of Smart Alerts that helps keep your heating and cooling system running correctly and efficiently. If Smart Alerts are set up by your HVAC professional, you can get reminders when it's time to change the filter and when your system is not running correctly.

Non-critical alerts and maintenance reminders can be snoozed for up to 7 days and/or dismissed. Some critical alerts cannot be snoozed or dismissed as your heating or cooling system may require service.

When there's an active alert or maintenance reminder, you'll see the alert symbol  on the thermostat home screen. To see alert information, follow the steps below.

- 1 Touch **Menu** on the thermostat home screen, then you'll see the ALERTS sub-menu. (The ALERTS sub-menu will only be available when there's an active alert.)
- 2 Touch **Select** to view the alert. A 3-digit alert code will appear by the thermostat's clock and a description of the alert will scroll on the screen.
- 3 If the alert is non-critical, you'll have the option to Snooze or Dismiss it. If you have multiple alerts, touch the  or  arrows to page through the list of active alerts and follow steps 1 and 2 above.

To see what each 3-digit alert code means and the action you should take, refer to the chart below.

Number	Alert/Reminder	Definition
54	Thermostat Humidity Sensor Error	The sensor of the thermostat has encountered an error. Please contact dealer to replace the thermostat.
164	Heat Pump Needs Service	Heat pump needs service. Contact dealer to diagnose and service heat pump.
170	Internal Memory Error	The memory of the thermostat has encountered an error. Please contact dealer for assistance.
171	Set the Date and Time	Set the date and time on your thermostat. The date and time are required for certain features to operate, like the program schedule.
173	Thermostat Temperature Sensor Error	The sensor of the thermostat has encountered an error. Please contact dealer to replace the Thermostat.
177	Indoor Temperature Sensor Error	Wired indoor temperature sensor is not connected or there is a wiring short. Please contact dealer for assistance.
178	Outdoor Temperature Sensor Error	Wired outdoor temperature sensor is not connected or there is a wiring short. Please contact dealer for assistance.
181	Replace Air Filter (1)	Replace air filter (1). Reset the timer by touching the "dismiss" button on thermostat screen after it is replaced.
182	Replace Air Filter (2)	Replace air filter (2). Reset the timer by touching the "dismiss" button on thermostat screen after it is replaced.

Number	Alert/Reminder	Definition
184	Replace Humidifier Pad	Replace humidifier pad. Reset the timer by touching the "dismiss" button on the thermostat screen after it is replaced.
185	Replace Dehumidifier Filter	Replace the dehumidifier filter. Reset the timer by touching "dismiss" button on thermostat screen after it is replaced.
186	Clean Ventilator Core	Clean ventilator core. Reset the timer by touching the "dismiss" button on thermostat screen after it is replaced.
187	Clean or Replace Ventilator Filter	Clean or replace ventilator filter. Reset the timer by touching the "dismiss" button on thermostat screen after it is replaced.
188	Replace UV Bulb (1)	Replace UV Bulb (1). Reset the timer by touching the "dismiss" button on thermostat screen after it is replaced.
189	Replace UV Bulb (2)	Replace UV Bulb (2). Reset the timer by touching the "dismiss" button on thermostat screen after it is replaced.
252	AC Power Lost	If batteries used as backup power it will drain batteries quickly and Z-Wave communication needs to be turned off. The working power mode can only be changed when thermostat is NOT included in a Z-Wave network. Either to exclude and include thermostat in to Z-Wave network to change the power mode to LSS (power-save, sleep mode) or to resume AC power. You can check the actual power mode in the thermostat <b>MENU/DEVICE INFO</b> .
405	Battery Low	Battery low. Please turn the system mode to off and replace the batteries.
407	Battery Critical	Battery critical. Thermostat cannot control your system. Please replace the batteries immediately.
546	Z-Wave Not Configured	Z-Wave has not been configured yet to receive commands from your Z-Wave network. Please follow steps on how to include thermostat in to Z-Wave network.
547	Z-Wave Radio Error	Z-Wave module is not operating. Thermostat cannot receive commands from your Z-Wave network. Please contact dealer to replace the thermostat.

# Troubleshooting

## Screen is blank

- Check circuit breaker and reset if necessary.
- Make sure power switch at heating and cooling system is on.
- Make sure furnace door is closed securely.
- If battery powered, make sure the batteries are fresh and correctly inserted.

## Screen is difficult to read

- Change screen brightness in thermostat **Menu**. Increase brightness intensity for inactive backlight of the thermostat screen (max. is level 5). Setting is only available if thermostat is AC powered

## Heating or cooling system does not respond

- Touch **Mode** to set system to Heat. Make sure the temperature is set higher than the Inside temperature.
- Touch **Mode** to set system to Cool. Make sure the temperature is set lower than the Inside temperature.
- Check circuit breaker and reset if necessary.
- Make sure power switch at heating & cooling system is on.
- Make sure furnace door is closed securely.

## Temperature settings do not change

Your installer may have set a range stop setting for heat or cooling. Contact your installer to verify the range stop settings on the thermostat. Default range stops settings are:

- Heat: 40 °F to 90 °F (4.5 °C to 32.0 °C)
- Cool: 50 °F to 99 °F (10.0 °C to 37.0 °C)

## “Cool On” or “Heat On” is flashing

- Compressor protection feature is engaged. Wait 5 minutes for the system to restart safely, without damage to the compressor (see page 8).

## 5-year warranty

Honeywell warrants this product, to be free from defects in the workmanship or materials, under normal use and service, for a period of five (5) years from the date of purchase by the consumer. If at any time during the warranty period the product is determined to be defective or malfunctions, Honeywell shall repair or replace it (at Honeywell's option).

If the product is defective,

(i) return it, with a bill of sale or other dated proof of purchase, to the place from which you purchased it; or

(ii) call Honeywell Customer Care at 1-800-468-1502. Customer Care will make the determination whether the product should be returned to the following address: Honeywell Return Goods, Dock 4 MN10-3860, 1985 Douglas Dr. N., Golden Valley, MN 55422, or whether a replacement product can be sent to you.

This warranty does not cover removal or reinstallation costs. This warranty shall not apply if it is shown by Honeywell that the defect or malfunction was caused by damage which occurred while the product was in the possession of a consumer.

Honeywell's sole responsibility shall be to repair or replace the product within the terms stated above. HONEYWELL SHALL NOT BE LIABLE FOR ANY LOSS OR DAMAGE OF ANY KIND, INCLUDING ANY INCIDENTAL OR CONSEQUENTIAL DAMAGES RESULTING, DIRECTLY OR INDIRECTLY, FROM ANY BREACH OF ANY WARRANTY, EXPRESS OR IMPLIED, OR ANY OTHER FAILURE OF THIS PRODUCT. Some states do not allow the exclusion or limitation of incidental or consequential damages, so this limitation may not apply to you.

THIS WARRANTY IS THE ONLY EXPRESS WARRANTY HONEYWELL MAKES ON THIS PRODUCT. THE DURATION OF ANY IMPLIED WARRANTIES, INCLUDING THE WARRANTIES OF MERCHANTABILITY AND FITNESS FOR A PARTICULAR PURPOSE, IS HEREBY LIMITED TO THE FIVE-YEAR DURATION OF THIS WARRANTY.

Some states do not allow limitations on how long an implied warranty lasts, so the above limitation may not apply to you. This warranty gives you specific legal rights, and you may have other rights which vary from state to state.

If you have any questions concerning this warranty, please write Honeywell Customer Relations, 1985 Douglas Dr, Golden Valley, MN 55422 or call 1-800-468-1502.

# General system information



## **CAUTION: ELECTRICAL HAZARD**

Can cause electrical shock or equipment damage. Disconnect power before beginning installation.



## **CAUTION: EQUIPMENT DAMAGE HAZARD**

Compressor protection is bypassed during testing. To prevent equipment damage, avoid cycling the compressor quickly.



## **CAUTION: MERCURY NOTICE**

If the T6 Pro Z-Wave thermostat is replacing a thermostat that contains mercury in a sealed tube, do not place the old thermostat in the trash. Please contact your local waste management authority for proper recycling or disposal instructions.

# Regulatory information

## **FCC REGULATIONS**

### **§ 15.19 (a)(3)**

This device complies with part 15 of the FCC Rules. Operation is subject to the following two conditions:

- This device may not cause harmful interference, and
- This device must accept any interference received, including interference that may cause undesired operation.

## **IC REGULATIONS**

### **RSS-GEN**

This device complies with Industry Canada's license-exempt RSSs.

Operation is subject to the following two conditions:

- This device may not cause interference; and
- This device must accept any interference, including interference that may cause undesired operation of the device.

## **FCC Warning (Part 15.21) (USA only)**

Changes or modifications not expressly approved by the party responsible for compliance could void the user's authority to operate the equipment.

## **Home and Building Technologies**

In the U.S.:

Honeywell International Inc.

715 Peachtree Street NE

Atlanta, GA 30308

<http://customer.honeywell.com>

\*U.S. Registered Trademark.

© 2017 Honeywell International Inc.

33-00296EFS-01 M.S. 09-17

Printed in U.S.A.



## T6 Pro Z-Wave

Programmable Thermostat

## Professional Install Guide

.....

### Package Includes:

- T6 PRO Z-Wave Thermostat
  - UWP™ Mounting System
  - Honeywell Standard Installation Adapter (J-box adapter)
  - Honeywell Decorative Cover Plate – Small; Size 4-49/64 in = 121mm.
  - Screws and anchors
  - 3 AA batteries
  - Professional Install Guide
  - Getting Started Guide
- .....



*\*TH6320ZW2003 depicted. Other models may vary.  
Actual size 4.09" x 4.09" x 1.06"*



## Compatibility

- Designed for battery operation (3 x AA batteries) or for 24 VAC power operation (via a "C" or common wire).
- Compatible with most single and multi-stage conventional and heat pump systems.
- Designed to work with any Z-Wave compliant controller or gateway; however, a security enabled Z-Wave Plus Controller is recommended to fully utilize all thermostat features.
- Works with millivolt systems.
- Does not work with electric baseboard heat (120-240V).

## User Guide

Visit [yourhome.honeywell.com](http://yourhome.honeywell.com) for a complete user guide.

## Customer assistance

For assistance with this product, please visit [customer.honeywell.com](http://customer.honeywell.com).  
Or call Honeywell Customer Care toll-free at **1-800-468-1502**.



33-00294-02

# Introduction

The Honeywell T6 Pro Z-Wave Programmable Thermostat is a Z-Wave Plus certified thermostat capable of controlling up to three heat and two cool stages of heat pump, (incl. dual fuel heat pump systems) and up to two heat and two cool stages of conventional system (3H/2C HP, 2H/2C Conv.)

It is one of the easiest smart thermostats to install and is controllable by all Z-Wave compliant controllers that have the control capability for "Thermostat" devices. When integrated with the app that controls your Z-Wave controller, it lets you to program and control your home's HVAC system as well as controlling other Z-Wave devices connected to the same Z-Wave controller.

Because the thermostat is battery-powered, low-voltage integrators can easily connect the thermostat to most HVAC systems. Optional 24 VAC powering via "C" or common wire is also available, if desired.



## CAUTION



- We strongly recommend that installation is performed by a trained HVAC technician.
- Read the enclosed instructions carefully before installing the new Honeywell T6 Pro Z-Wave Programmable Thermostat.
- **ELECTRICAL HAZARD:** Can cause electrical shock or equipment damage. Disconnect power before beginning installation.
- To prevent abnormal operation, it is highly recommended to configure the installer setup and set the thermostat to correct HVAC system before including the thermostat to Z-Wave network.
- Before disconnecting wires from the existing thermostat, label the wires with the terminal markings from the old thermostat and record them. Take a picture of the old wiring.
- Use 3 new AA batteries in the thermostat.

# UWP Mounting System installation

1. Open package to find the UWP. See Figure 1.
2. Position the UWP on the wall. Level and mark hole positions. See Figure 2.  
Drill holes at marked positions, and then lightly tap supplied wall anchors into wall using a hammer.  
- Drill 7/32" holes for drywall.
3. Pull the door open and insert wires through wiring hole of the UWP. See Figure 3.
4. Place the UWP over the wall anchors. Insert and tighten mounting screws supplied with the UWP. Do not overtighten. Tighten until the UWP no longer moves. Close the door. See Figure 4.

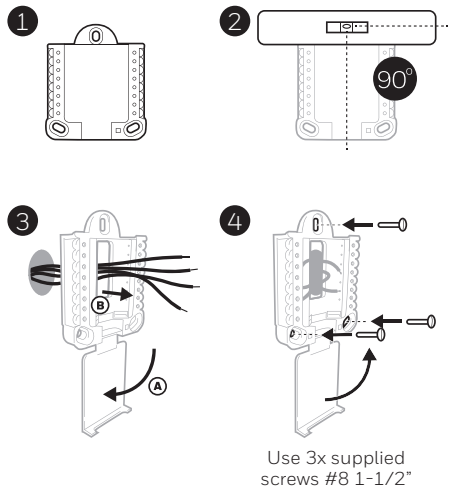

# Optional Decorative Cover Plate installation

Use the **Optional Cover Plate** when:

- Mounting the thermostat to an electrical junction box
  - Or when you need to cover paint gap from the old thermostat.
5. Separate the Junction Box Adapter from the Cover Plate. See Figure 5.
  6. Mount the Junction Box Adapter to the wall or an electrical box using any of the eight screw holes. Insert and tighten mounting screws supplied with Cover Plate Kit. Do not overtighten. Make sure the Adapter Plate is level. See Figure 6.
  7. Attach the UWP by hanging it on the top hook of the Junction Box Adapter and then snapping the bottom of the UWP in place. See Figure 7.
  8. Snap the Cover Plate onto the Junction Box Adapter. See Figure 8.

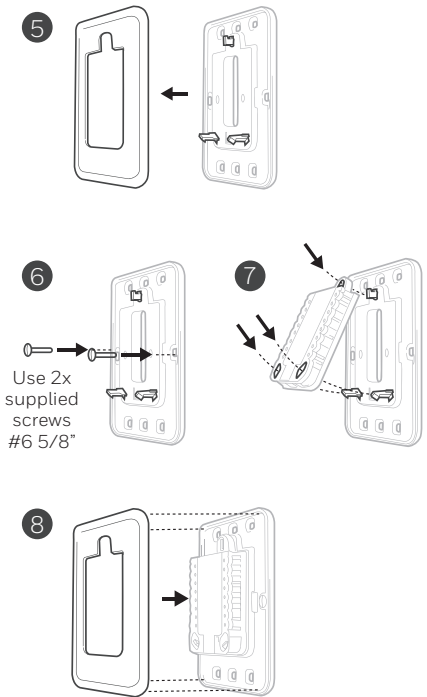

# Power options

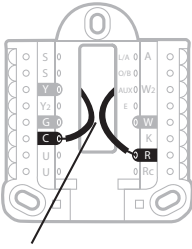

Insert **R** and **C** wires into designated terminals for primary AC power (C terminal is optional if batteries are installed, but it is recommended). Remove wires by depressing the terminal tabs.

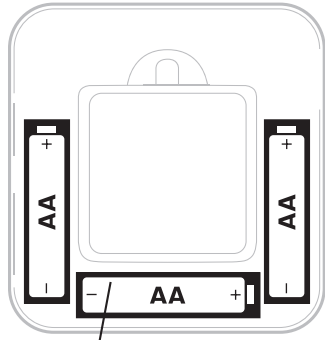

Insert 3 AA batteries for primary or backup power. Match the polarity of the batteries with the + / - marks inside the battery compartment.

## NOTES:

- The T6 Pro Z-Wave thermostat works in battery mode or normal power mode based on its power source. The Z-Wave power mode can only be changed when the thermostat is NOT included in a Z-Wave network. You can check the power mode in the thermostat menu under **MENU/DEVICE INFO**.
- If a C wire is not used, or present, the thermostat must be powered by batteries. The thermostat will operate in LSS mode (power-save, sleep mode) to help conserve battery life after it has been included in a Z-Wave network. The Z-Wave radio supports beaming. It allows other devices in the network to wake up the Z-Wave thermostat, accept commands, and then go back to sleep.
- If you need the thermostat to operate in AOS mode (always listening mode) to act as signal repeater and to increase network reliability, you need to power the thermostat by 24 VAC. The AOS mode information is provided via Node Information Frame (NIF).

# Wiring UWP

Push down on the tabs to put the wires into the inner holes of their corresponding terminals on the UWP (one wire per terminal) until they are firmly in place. **Gently tug on the wires to verify they are secure.** If you need to release the wires again, push down the terminal tabs on the sides of the UWP.

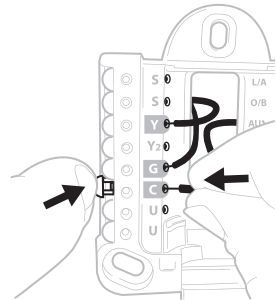

This wiring is just an example, yours may vary.

# Setting Slider Tabs

## Set R Slider Tab.

- Use built-in jumper (**R Slider Tab**) to differentiate between one or two transformer systems.
- If there is only one R wire, and it is connected to the **R**, **Rc**, or **RH** terminal, set the slider to the up position (**1 wire**).
- If there is one wire connected to the **R** terminal and one wire connected to the **Rc** terminal, set the slider to the down position (**2 wires**).

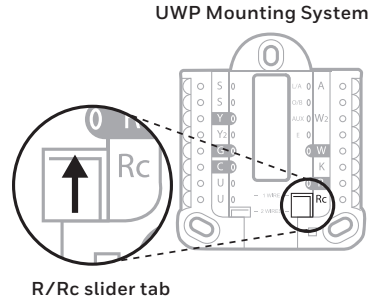

**NOTE:** Slider Tabs for U terminals should be left in place for other thermostat models.

## Wiring terminal designations

<b>S</b>	Input for wired indoor or outdoor sensors	<b>L/A - A</b>	Heat Pump fault input
<b>S</b>		<b>O/B</b>	Changeover valve
<b>Y</b>	Compressor contactor (stage 1)	<b>AUX - W2</b>	Auxiliary heat relay Heat relay (stage 2)
<b>Y2</b>	Compressor contactor (stage 2)	<b>E</b>	Emergency Heat relay
<b>G</b>	Fan Relay	<b>W</b>	Heat relay (stage 1)
<b>C</b>	24 VAC common. For 2 transformer systems, use common wire from cooling transformer.	<b>K</b>	Connect to K on Wire Saver Module**
<b>U</b>	Unused	<b>R</b>	24 VAC power from heating transformer*
<b>U</b>		<b>Rc</b>	24 VAC power from cooling transformer*

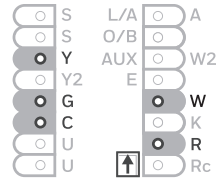

Note: Not all terminals may be used, depending on the system type that is being wired. The most commonly used terminals are shaded.

\* Terminal can be jumped using Slider Tab. See “Setting Slider Tabs” above.

\*\* The THP9045A1023 Wire Saver Module can be used on heat/cool systems when you only have four wires at the thermostat, and you need a fifth wire for a common wire. Use the K terminal in place of the Y and G terminals on conventional or heat pump systems to provide control of the fan and the compressor through a single wire—the unused wire then becomes your common wire. See THP9045 instructions for more information.

# Wiring conventional systems: forced air and hydronics

## 1H/1C System (1 transformer)

**R** Power [1]  
**Rc** [R+Rc joined by Slider Tab] [2]  
**Y** Compressor contactor  
**C** 24 VAC common [3]  
**W** Heat relay  
**G** Fan relay

## Heat-only System

**R** Power [1]  
**Rc** [R+Rc joined by Slider Tab] [2]  
**C** 24 VAC common [3]  
**W** Heat relay

## Heat-only System (Series 20) [5]

**R** Series 20 valve terminal "R" [1]  
**Rc** [R+Rc joined by Slider Tab] [2]  
**Y** Series 20 valve terminal "W"  
**C** 24 VAC common [3]  
**W** Series 20 valve terminal "B"

## Heat-only System

(power open zone valve) [5]

**R** Power [1]  
**Rc** [R+Rc joined by Slider Tab] [2]  
**W** Valve  
**C** 24 VAC common [3]

## 1H/1C System (2 transformers)

**R** Power (heating transformer) [1]  
**Rc** Power (cooling transformer) [1]  
**Y** Compressor contactor  
**C** 24 VAC common [3, 4]  
**W** Heat relay  
**G** Fan relay

## Heat-only System with Fan

**R** Power [1]  
**Rc** [R+Rc joined by Slider Tab] [2]  
**C** 24 VAC common [3]  
**W** Heat relay  
**G** Fan relay

## Cool-only System

**R** Power [1]  
**Rc** [R+Rc joined by Slider Tab] [2]  
**Y** Compressor contactor  
**C** 24 VAC common [3]  
**G** Fan relay

## 2H/2C System (1 transformer) [6]

**R** Power [1]  
**Rc** [R+Rc joined by Slider Tab] [2]  
**Y** Compressor contactor (stage 1)  
**C** 24 VAC common [3]  
**W** Heat relay (stage 1)  
**G** Fan relay  
**W2** Heat relay (stage 2)  
**Y2** Compressor contactor (stage 2)

## NOTES:

- Available wiring configurations may differ by product models/product numbers.
- Wire specifications: Use 18- to 22-gauge thermostat wire. Shielded cable is not required.

- [1] Power supply. Provide disconnect means and overload protection as required.
- [2] Move R-Slider Tab on UWP to the **R** setting. For more information, see "Setting Slider Tabs" on page 5.
- [3] Optional 24 VAC common connection.
- [4] If you do not have separate wires for the Aux and E terminals, connect the wire to the Aux terminal.

- [5] In Installer Setup Options (ISU), set system type to Boiler. Set number of cool stages to 0.
- [6] In Installer Setup Options (ISU), set system type to Conventional. Set cool stages to 2, and set heat stages to 2.

# Wiring heat pump systems

## 1H/1C Heat Pump System

**R** Power [1]  
**Rc** [R+Rc joined by Slider Tab] [2]  
**Y** Compressor contactor  
**C** 24 VAC common [3]  
**O/B** Changeover valve [7]  
**G** Fan relay

## 2H/1C Heat Pump System [8]

**R** Power [1]  
**Rc** [R+Rc joined by Slider Tab] [2]  
**Y** Compressor contactor  
**C** 24 VAC common [3]  
**O/B** Changeover valve [7]  
**G** Fan relay  
**Aux** Auxiliary heat [4]  
**E** Emergency heat relay [4]  
**L** Heat pump fault input

## 2H/2C Heat Pump System [6]

**R** Power [1]  
**Rc** [R+Rc joined by Slider Tab] [2]  
**Y** Compressor contactor (stage 1)  
**C** 24 VAC common [3]  
**O/B** Changeover valve [7]  
**G** Fan relay  
**Y2** Compressor contactor (stage 2)  
**L** Heat pump fault input

## 3H/2C Heat Pump System [10]

**R** Power [1]  
**Rc** [R+Rc joined by Slider Tab] [2]  
**Y** Compressor contactor (stage 1)  
**C** 24 VAC common [3]  
**O/B** Changeover valve [7]  
**G** Fan relay  
**Aux** Auxiliary heat [4]  
**E** Emergency heat relay [4]  
**Y2** Compressor contactor (stage 2)  
**L** Heat pump fault input

## Dual Fuel System

**R** Power [1]  
**Rc** [R+Rc joined by Slider Tab] [2]  
**Y** Compressor contactor (stage 1)  
**C** 24 VAC common [3]  
**O/B** Changeover valve [7]  
**G** Fan relay  
**Aux** Auxiliary heat [4]  
**E** Emergency heat relay [4]  
**Y2** Compressor contactor (stage 2 - if needed)  
**L** Heat pump fault input  
**S** Outdoor sensor  
**S** Outdoor sensor

## NOTES:

- Do **NOT** use **W** for heat pump applications. Auxiliary heat must wire to **AUX** or **E**.
- Available wiring configurations may differ by product models/product numbers.
- Wire specifications: Use 18- to 22-gauge thermostat wire. Shielded cable is not required.

- [1] Power supply. Provide disconnect means and overload protection as required.
- [2] Move R-Slider Tab on UWP to the **R** setting. For more information, see "Setting Slider Tabs" on page 5.
- [3] Optional 24 VAC common connection.
- [4] If you do not have separate wires for the Aux and E terminals, connect the wire to the Aux terminal.
- [6] In Installer Setup Options (ISU), set system type to Heat Pump. Set compressor stages to 2, and set Aux/E stages to 0.
- [7] In Installer Setup Options (ISU), set Reversing Valve to O/B on Cool (for cool changeover) or to O/B on Heat (for heat changeover).
- [8] In Installer Setup Options (ISU), set heat system type to Heat Pump. Set compressor stages to 1, and set Aux/E stages to 1.
- [10] In Installer Setup Options (ISU), set system type to Heat Pump, set compressor stages to 2, and set Aux/E stages to 1.

# Mounting thermostat

- 1 Push excess wire back into the wall opening.
- 2 Close the UWP door. It should remain closed without bulging.
- 3 Align the UWP with the thermostat, and push gently until the thermostat snaps in place.
- 4 If needed, gently pull to remove the thermostat from the UWP.
- 5 Turn the power on at the breaker box or switch.

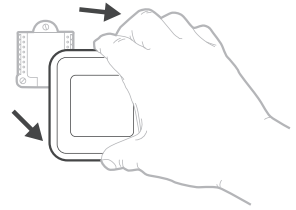
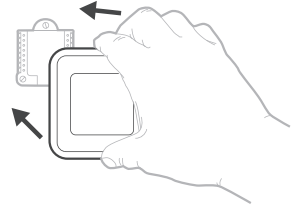

# Initial installer setup

- After the T6 Pro Z-Wave thermostat has powered up, touch **START SETUP** on the thermostat.
- Touch or to toggle between Installer Set Up (ISU) options.
- Touch **Edit** or touch text area, and then touch or to edit default setup option.
- Touch **Done** or touch text area to confirm the setting or press **Cancel**.
- Touch or to continue to setup another ISU option.
- To finish setup and save your settings, scroll to the **Finish** screen at the end of the ISU list.

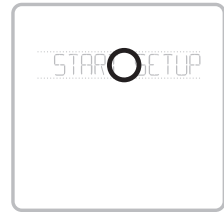

View ISU

ISU option and name (scrolling)      Arrow buttons used to scroll through ISUs

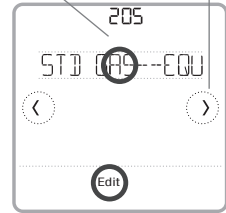

Edit ISU

ISU option blinking      ISU #      Arrow buttons used to scroll through ISU options

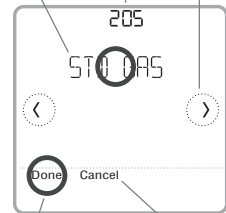

Saves selected ISU option moves on to the next ISU screen

Cancel ISU option selection, go back to view ISU

## NOTES:

- To see a list of all setup parameters, go to "Installer setup options (ISU) – advanced menu" on page 14. The thermostat displays the ISU name and the ISU number.
- To prevent abnormal operation, it is highly recommended to perform installer setup and set thermostat to correct HVAC system before including it in a Z-Wave network.



# Z-Wave setup

After you finish the installer setup and set the date and time, you will be asked to set up a Z-Wave to include the thermostat into Z-Wave network.

- Touch **Yes** to include the thermostat in to Z-Wave network, or touch **No** if you want this to be done later.
- You'll be asked to set your primary controller to **INCLUDE MODE**. Please refer to the user manual of your Z-Wave controller.
- After inclusion procedure has been initiated on your Z-Wave controller, touch **Select** on the thermostat.
- If the inclusion procedure is successful, **INCLUDED**, the node ID, and the Z-Wave connected status icon appear on the screen. If the procedure fails, **FAILED TO INCLUDE** appears on the screen. If this happens, position the thermostat closer to the Z-Wave controller and repeat the inclusion procedure.
- Your controller will indicate whether the thermostat was successfully added to its network. (Please refer to the user manual of your Z-Wave controller.)





## NOTES:

- To include or exclude the thermostat from Z-Wave network after initial thermostat setup, go to thermostat **MENU/Z-WAVE SETUP**.
- Before adding the thermostat to a Z-Wave network, check that it does not already belong to one. If the thermostat is included in Z-Wave network, it offers to exclude. If the thermostat is excluded from Z-Wave network, it offers to include. You can also check the status by viewing the **Node ID** located in the thermostat **MENU/DEVICE INFO**. An excluded thermostat should show zero for the Node ID (000).
- Whether you are including or excluding the thermostat from Z-Wave network, first you have to initiate it on your Z-Wave controller. Please refer to the user manual of your Z-wave controller.
- For other specific tasks such as adding the thermostat to home automation scenes or groups, refer to the user manual of your Z-Wave controller.

# Z-Wave connection status

Z-Wave connection status is located in the upper-right corner of the screen.

-  • Thermostat is included and connected to a Z-Wave network.
-  • Thermostat is excluded from a Z-Wave network.
-  • Thermostat is either included in a Z-Wave network but the Z-Wave signal is lost, or is included but AC power is lost (battery used as backup). In this case, Z-Wave radio is turned off to preserve battery life. AC power must be restored or you have to change the power mode. It can be done via excluding thermostat from Z-wave network and including again in battery power mode where batteries are used as main power source. You can check the actual power mode in the thermostat **MENU/DEVICE INFO**.



Example of thermostat included and connected in a Z-Wave network.

# System operation setting

- 1 Press the **Mode** button to cycle to the next available System mode.
- 2 Cycle through the modes until the required System mode is displayed and leave it to activate.

## System modes:

- **Heat:** Controls the heating system.
- **Cool:** Controls the cooling system.
- **Off:** Turns the heating and cooling systems off.
- **Auto:** When enabled, the thermostat will automatically use heating or cooling to reach the desired temperature.
- **Em Heat:** Controls auxiliary or emergency heat; only available on systems with a heat pump.

## NOTES:

- Em Heat and Auto modes may not appear on the thermostat screen, depending on your equipment and how the thermostat was configured.
- Em Heat is only available if the thermostat is configured to control a heat pump and an auxiliary/emergency heat stage.
- When Auto mode is enabled and initiated, **Auto Chg. On** will appear in the upper-right corner of the thermostat home screen, and the active mode (Heat or Cool) will be displayed. Auto mode is disabled by default. To enable it, see "Installer setup – advanced menu" on page 13.

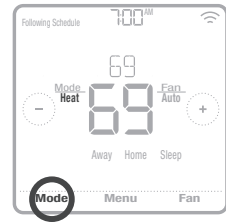

# Fan operation setting

- 1 Press the **Fan** button to cycle to the next available Fan mode.
- 2 Cycle through the modes until the required Fan mode is displayed and leave it to activate.

**NOTE:** Available Fan modes vary with system settings.

## Fan modes:

- **On:** The fan will run continuously.
- **Auto:** The fan will run only when the heating or cooling system is on.
- **Circ:** The fan will run at random intervals at least 35% of the time to keep air circulating throughout your home.



# Scheduling options

The T6 Pro thermostat offers flexible scheduling options, which differ depending on whether the thermostat is included/excluded from Z-Wave network.

- |                              |                                   |
|------------------------------|-----------------------------------|
| <b>1 No schedule</b>         | <b>3 Occupancy based schedule</b> |
| <b>2 Time based schedule</b> | <b>4 Smart schedule</b>           |

## If the thermostat is not included in Z-Wave network:

The thermostat can be set as non-programmable (1), or you can program and follow a schedule based on the time of day and day of the week (2).

The default program schedule is 5-2 (Mon-Fri; Sat-Sun), with different settings for weekdays and weekends, four time periods per day. See the table below for the default settings, which have adjustable periods and temperature setpoints.

Time based schedule:					
Period	Start Time	Heat (Mon-Fri)	Cool (Mon-Fri)	Heat (Sat-Sun)	Cool (Sat-Sun)
Wake	6:00 AM	70 °	78 °	70 °	78 °
Away	8:00 AM	62 °	85 °	62 °	85 °
Home	6:00 PM	70 °	78 °	70 °	78 °
Sleep	10:00 PM	62 °	85 °	62 °	85 °

## If the thermostat is included in Z-Wave network:

It typically follows the settings of your Z-Wave controller. When not in Away mode, it can either follow your Home temperature setpoint based on occupancy states (Home/Away) sent by Z-Wave controller (3) or it can even differentiate between Home and Sleep temperature setpoints according to actual time period (4).

The default program schedule is the Smart schedule, 5-2 (Mon-Fri; Sat-Sun), with different settings for weekdays and weekends. See the table below for the default settings, which have adjustable periods and temperature setpoints.

Smart Schedule:					
Period	Start Time	Heat (Mon-Fri)	Cool (Mon-Fri)	Heat (Sat-Sun)	Cool (Sat-Sun)
Away	N/A*	62 °	85 °	62 °	85 °
Home	6:00 AM	70 °	78 °	70 °	78 °
Sleep	10:00 PM	62 °	85 °	62 °	85 °

To turn the Smart schedule off and to use just Occupancy based schedule (Home/Away temperature setpoints only), go to thermostat **MENU/SCHEDULE** and turn the Time based schedule Off. See table below with default, adjustable temperature setpoints.

Occupancy based schedule:			
Period	Start Time	Heat	Cool
Away	N/A*	62 °	85 °
Home	N/A*	72 °	78 °

\*Triggered by Z-Wave controller



## NOTES (for when the thermostat is INCLUDED in Z-Wave network):

- Away mode is an Energy saving setback mode triggered by Z-Wave controller or gateway.
- Away setpoint is adjustable and common for all days, configurable in the thermostat **MENU/AWAY SETTING**.
- Home setpoint in the Occupancy based schedule is temperature setpoint adjustable on the thermostat Home screen. Common for all days.
- Home and Sleep temperature setpoints in the Smart schedule are configurable in the thermostat **MENU/SCHEDULE**.

# Key features

## System status information

Cool On, Heat On  
Emergency Heat On,  
Recovery, or Auto  
Changeover On.

## Schedule information

Following time and  
occupancy based  
temperature control.

## Desired temperature

Displays the current  
desired temperature  
setting.

## Indoor temperature/ % indoor relative humidity

Touch to display  
either current indoor  
temperature or current %  
indoor relative humidity

## Mode

Select system mode:  
Auto/Heat/Cool/Off/EM  
Heat (Emergency Heat).

## Time, ISU #, or Alert #

## Z-Wave connection status

Shows actual Z-Wave  
connection status.

## Messaging

Shows device setup  
options, menu options,  
reminders, schedule  
overrides.

## Schedule period

Shows schedule period:  
Away/Home/Sleep.

## Fan

Select Fan mode Auto/  
On/Circulate.

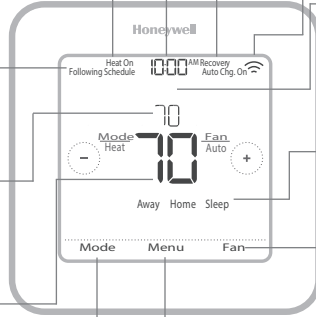

## Menu

Touch to display user  
options.



**Note: Long press  
of Menu button  
for 5 seconds to  
access Advanced  
Menu options.**

The screen will wake up by pressing the center area of the displayed temperature. If powered by 24 VAC, the screen stays lit for 45 seconds after you complete changes.

If powered by battery only, the screen stays lit for 8 seconds.

Brightness of an inactive backlight can be adjusted in the thermostat **MENU** only if the thermostat is powered by 24 VAC.

# Installer setup – advanced menu

To access the advanced menu, press and hold the **Menu** button for **5 seconds**. Touch  or  to go through the options in the advanced menu.

## Advanced menu options

### Device Setup

This is used to access the device ISU setting.

### Screen Lock

The thermostat touch screen can be locked fully or partially.

### System Test

Test the heating and cooling system.

### Reset

Access all reset options on the thermostat. This is the only place to access factory reset.

### Range Stop (Temperature)

Set the Minimum Cool and Maximum Heat temperature set points.

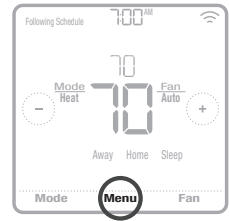

Press and hold for 5 seconds.

# Installer setup options (ISU) – advanced menu

Table 1.

**Note:** ISU options available may vary upon the thermostat model and equipment setup.

# ISU	ISU Name	ISU Options (defaults in bold)	Notes
120	Schedule Type	No Schedule or Occupancy MO-SU = Every day the same MO-FR, SA, SU = 5-1-1 schedule <b>MO-FR, SA-SU = 5-2 schedule</b> Each Day = Every day individual.	You can change default MO-FR, SA-SU schedule here. To edit periods during days; temperature setpoints, or to turn <b>Schedule On/Off</b> , go to <b>MENU/SCHEDULE</b> (only available if schedule is set).
125	Temp Scale	<b>Fahrenheit</b> , Celsius	
130	Outdoor Temp	<b>No</b> , Wired	An outdoor temperature is required to set the following ISUs; ISU 355 Balance point (Compressor Lockout), ISU 356 Aux Heat Lockout. Use a wired outdoor sensor connected to the "S" terminals on the UWP and set this ISU to Wired. ("Wiring heat pump systems" on page 7.)
200	System Type	<b>Conventional Forced Air</b> Heat Pump Boiler Cool Only	Basic selection of system your thermostat will control.
205	Equipment Type	<i>Conventional Forced Air Heat:</i> <b>Standard Efficiency Gas (STD GAS), High Efficiency Gas (EFF GAS)</b> , Oil, Electric, Hot Water Fan Coil  <i>Heat Pump:</i> <b>Air To Air</b> , Geothermal  <i>Boiler:</i> <b>Hot Water Radiant Heat</b> , Steam	This option selects the equipment type your thermostat will control. Note: This option is NOT displayed if ISU 200 is set to Cool Only.
218	Reversing Valve	<b>O/B on Cool</b> , O/B on Heat	This ISU is only displayed if ISU 200 is set to Heat Pump. Select whether reversing valve O/B should energize on cool or on heat.
220	Cool Stages (#200=Conv./200=HP)	<b>0, 1, 2</b>	
221	Heat Stages; Aux/E Stages (#200=Conv.; 200=HP)	Heat Stages: <b>0, 1, 2</b> Aux/E Stages: <b>0, 1</b>	Maximum of 2 Heat Stages for conventional systems. Maximum of 1 Aux/E stages for heat pump systems.
230	Fan Control	Equipment, <b>Thermostat</b>	This ISU is only displayed if ISU 205 is set to Electric Forced Air or Fan Coil.
253	Aux/E Control	<b>Both Aux/E</b> , Either Aux/E	Set "EITHER AUX/E" if you want to setup and control of Auxiliary and Emergency heating separately. This ISU is only displayed if ISU 200 is set to Heat Pump AND if ISU 221 Aux/E stages = 1.
255	Aux Heat Type	<b>Electric</b> , Gas/Oil (or Fossil Forced Air)	This ISU is displayed only if ISU 200 is set to heat pump AND if ISU 221 Aux/E heat stages = 1.

# Installer setup options (ISU) – advanced menu

Table 2.

# ISU	ISU Name	ISU Options (defaults in bold)	Notes
256	EM Heat Type	<b>Electric</b> , Gas/Oil (or Fossil/Forced Air)	This ISU is displayed only if ISU 200 is set to Heat Pump AND if ISU 221 Aux/E heat stages = 1 AND if ISU 253 is set to run AUX/E heat separately.
260	Fossil Kit Control	<b>Thermostat</b> , External (Fossil Fuel Kit Controls Backup Heat)	This ISU is displayed only if ISU 200 is set to Heat Pump AND if ISU 221 Aux/E heat stages = 1, AND if ISU 256 is set to Gas/Oil.
300	Auto Changeover	On, <b>Off</b>	<b>OFF:</b> The user must select heating or cooling as needed to maintain the desired indoor temperature. <b>ON (Automatic):</b> On (enabled) Allows user to select Auto Changeover as one of the system modes from the home screen. In auto mode, the thermostat control either heating or cooling automatically to maintain the desired indoor temperature.
303	Auto Differential	<b>0 °F</b> to 5 °F or <b>0.0 °C</b> to 2.5 °C	Differential is NOT deadband. Honeywell uses an advanced algorithm that fixes deadband at 0 °F. The differential setting is the minimum number of degrees from set-point needed to switch from the last mode running (heat or cool) to the opposite mode when the thermostat is in auto-changeover. This is more advanced than previous thermostats.
305	High Cool Stage Finish	Yes, <b>No</b>	This ISU is only displayed when the thermostat is set to 2 cool stages. When set to YES, this feature keeps the higher stage of the cooling equipment running until the desired setpoint is reached.
306	High Heat Stage Finish	Yes, <b>No</b>	This ISU is only displayed when the thermostat is set to 2 or more heat stages. When set to YES, this feature keeps the higher stage of the heating equipment running until the desired setpoint is reached.
340	Aux Heat Droop	<b>0 - Comfort</b> ; 2 °F to 1.5 °F from setpoint (in 1 °F increments) or 1.0 °C to 7.5 °C from setpoint (in 0.5 °C increments)	Aux heat droop can be set on heat pump systems with an auxiliary heat stage. The Comfort setting is NOT available for Dual Fuel systems. Default setting is 0 °F (Comfort) for Electric while 2 °F for Gas/Oil. The indoor temperature must drop to the selected droop setting before the thermostat will turn Aux Heat on. For example, if Aux Heat is set to 2 °F (1.0 °C), the indoor temperature must be 2 °F (1.0 °C) away from the setpoint before Aux Heat turns on. When set to Comfort, the thermostat will use Aux Heat as needed to keep the indoor temperature within 1 °F (0.5 °C) degree of the setpoint.
350	Up Stage Timer Aux Heat	<b>Off</b> , 30, 45, 60, 75, 90 minutes 2, 3, 4, 5, 6, 8, 10, 12, 14, 16 hours	The Auxiliary Heat Upstage Timer starts when the highest stage of the previous heating equipment type turns on. Auxiliary heat will be used (if needed) when the timer expires. This ISU is only displayed when ISU 340 (Aux Heat Droop) is set to 2 °F or higher.
355	Balance Point (Compressor Lockout)	<b>Off</b> , 5 °F to 60 °F (in 5 °F increments) or 15.0 °C to 15.5 °C (in 2.5 °C or 3.0 °C increments)	Compressor Lockout requires an outdoor temperature. Set Compressor Lockout to the temperature below which it is inefficient to run the heat pump. When outside temperature is below this setting, thermostat will lockout the heat pump and run Aux Heat only. This ISU is only displayed if ISU 130 – Wired, ISU 200 is set to Heat Pump, ISU 221 Aux/E stages = 1, AND ISU 260 is set to Thermostat. Default is 40 °F; if ISU 205 Heating Equipment is Air to Air Heat Pump and ISU 255 Aux Heat Type is Gas/Oil, Default is Off; if ISU 205 Heating Equipment is Air to Air Heat Pump and ISU 255 Aux Heat Type is Electric, Default is Off; if ISU 205 Heating Equipment is Geothermal, Compressor Lockout is optional for any type of heat pump (Air to Air Heat Pump, Geothermal Heat Pump).

# Installer setup options (ISU) – advanced menu

Table 3.

# ISU	ISU Name	ISU Options (defaults in bold)	Notes
356	Aux Heat Lock Out (Aux Heat Outdoor Lockout)	<b>Off</b> , 5 °F to 65 °F (in 5 °F increments) or -15.0 °C to 18.5 °C (in 2.5 °C or 3.0 °C increments)	Aux Heat Lockout requires an outdoor temperature. Set Aux Heat Lockout to optimize energy bills and to not allow to run the more expensive Aux Heat source above certain outdoor temperature limit. This ISU is only displayed if ISU 200 is set to Heat Pump, AND ISU 260 is set to Thermostat control AND if ISU 221 Aux/E stages = 1.
365	Cool 1 CPH (Cooling cycle rate stage 1)	<b>1 - 6 CPH (3 CPH)</b>	This ISU is only displayed when Cool /Compressor Stages is set to 1 or more stages. Cycle rate limits the maximum number of times the system can cycle in a 1 hour period measured at a 50% load. For example, when set to 3 CPH, at a 50% load, the most the system will cycle 3 times per hour (10 minutes on, 10 minutes off). The system cycles less often when load conditions are less than or greater than a 50% load.
366	Cool 2 CPH (Cooling cycle rate stage 2)	<b>1 - 6 CPH (3 CPH)</b>	This ISU is only displayed when Cool /Compressor Stages is set to 2.
370	Heat 1 CPH (Heating cycle rate stage 1)	<b>1 - 12 CPH</b>	This ISU is only displayed when Heat Stages is set to 1 stage or more stages. Cycle rate limits the maximum number of times the system can cycle in a 1 hour period measured at a 50% load. For example, when set to 3 CPH, at a 50% load, the most the system will cycle is 3 times per hour (10 minutes on, 10 minutes off). The system cycles less often when load conditions are less than or greater than a 50% load. The recommended (default) cycle rate settings are below for each heating equipment type: <b>Standard Efficiency Gas Forced Air = 5 CPH; High Efficiency Gas Forced Air = 3 CPH; Oil Forced Air = 5 CPH; Electric Forced Air = 9 CPH; Fan Coil = 3 CPH; Hot Water Radiant Heat = 3 CPH; Steam = 1 CPH.</b>
371	Heat 2 CPH (Heating cycle rate stage 2)	<b>1 - 12 CPH</b>	This ISU is only displayed when Heat Stages is set to 2 stages. The recommended (default) cycle rate settings are below for each heating equipment type: <b>Standard Efficiency Gas Forced Air = 5 CPH; High Efficiency Gas Forced Air = 3 CPH; Oil Forced Air = 5 CPH; Electric Forced Air = 9 CPH; Fan Coil = 3 CPH; Hot Water Radiant Heat = 3 CPH; Steam = 1 CPH.</b>
375	Aux Heat CPH (Heating cycle rate Auxiliary Heat)	<b>1 - 12 CPH</b>	This ISU is only displayed when ISU 200 = Heat Pump and ISU 221=1. It is only displayed when Auxiliary Heat is configured. The recommended cycle rate settings are below for each heating equipment type: <b>Standard Efficiency Gas Forced Air = 5 CPH; High Efficiency Gas Forced Air = 3 CPH; Oil Forced Air = 5 CPH; Electric Forced Air = 9 CPH</b>
378	EW Heat CPH (Heating cycle rate Emergency Heat)	<b>1 - 12 CPH</b>	This ISU is only displayed when Emergency Heat is configured and ISU 253; Aux/E Terminal Control is set to control Aux and E heat independently. The recommended cycle rate settings are below for each heating equipment type: <b>Standard Efficiency Gas Forced Air = 5 CPH; High Efficiency Gas Forced Air = 3 CPH; Oil Forced Air = 5 CPH; Electric Forced Air = 9 CPH.</b>
387	Compressor Protection	<b>Off</b> , 1 - 5 minutes	The thermostat has a built in compressor protection (minimum off timer) that prevents the compressor from restarting too early after a shutdown. The minimum-off timer is activated after the compressor turns off. If there is a call during the minimum-off timer, the thermostat shows "Cool on" or "Heat on" (heat pump) status blinking on the thermostat home screen. This ISU is displayed if ISU 220 is set to at least 1 stage.
390	Ext Fan Run Time in Cool	<b>Off</b> , 30, 60, 90 seconds 2, 3, 4, 5, 6, 7, 8, 9, 10, 11, 12, 13, 14, 15 minutes	After the call for cooling ends, the thermostat keeps the fan on for the selected amount of time for increased efficiency. This may reintroduce humidity into the living space. This ISU is displayed if ISU 220 is set to at least 1 stage.



# Installer setup options (ISU) – advanced menu

Table 4.

# ISU	ISU Name	ISU Options (defaults in bold)	Notes
391	Ext Fan Run Time in Heat	<b>Off</b> , 30, 60, 90 seconds 2, 3, 4, 5, 6, 7, 8, 9, 10, 11, 12, 13, 14, 15 minutes	After the call for heating ends, the thermostat keeps the fan on for the selected amount of time for increased efficiency. This ISU is displayed if ISU 230 is set to Thermostat Controls Fan.
425	Adaptive Recovery	<b>On, Off</b>	Adaptive Intelligent Recovery (AIR) is a comfort setting. Heating or cooling equipment will turn on earlier, ensuring the indoor temperature will match the setpoint at the scheduled time.
430	Minimum Cool Setpoint	50 °F to 99 °F ( <b>50 °F</b> ); 10.0 °C to 37.0 °C ( <b>10.0 °C</b> )	The user cannot set the cooling temperature below this level.
431	Maximum Heat Setpoint	40 °F to 90 °F ( <b>90 °F</b> ); 4.5 °C to 32.0 °C ( <b>32.2 °C</b> )	The user cannot set the heating temperature above this level.
435	Lock Screen	<b>None</b> , Partial, Full	<b>Unlocked:</b> User has access to all thermostat settings. <b>Partially Locked:</b> User can modify only temperature settings. <b>Fully Locked:</b> User cannot modify any settings. Screen will be locked by default factory code and cannot be changed. This code is displayed for a short time, when you are about to lock the thermostat screen. Please note the code in safe place for future reference.
500	Indoor Sensor	Yes, <b>No</b>	Set this ISU when you want to wire a remote indoor sensor to the "S" terminals on the UWP - see "Wiring conventional systems: forced air and hydronics" on page 6. This ISU is only displayed only if ISU 130 is set to NO wired outdoor sensor configured.
515	Sensor type	<b>10k</b> , 20k	Choose resistance type of wired indoor sensor. This ISU is only displayed when indoor sensor is configured - ISU 500.
520	Temperature Control	Thermostat, Wired, <b>Average</b>	This ISU is only displayed when indoor sensor is configured - ISU 500. You can choose what temperature source to be used or you can ask thermostat to use both thermostat and remote sensors for higher accuracy of measurement.
702	Air Filters	<b>0 - 2</b>	This ISU refers to the number of air filters in the system.
711	Air Filter 1 Reminder	<b>Off</b> 10, 20, 30, 45, 60, 90, 120, 150 Run Time Days 30, 45, 60, 75 Days 3, 4, 5, 6, 9, 12, 15 Months	Choose either calendar or equipment run time-based reminder.
712	Air Filter 2 Reminder	<b>Off</b> 10, 20, 30, 45, 60, 90, 120, 150 Run Time Days 30, 45, 60, 75 Days 3, 4, 5, 6, 9, 12, 15 Months	Choose either calendar or equipment run time-based reminder.
810	Hum Pad Reminder	<b>Off</b> 6, 12 Calendar Months	

# Installer setup options (ISU) – advanced menu

Table 5.









# ISU	ISU Name	ISU Options (defaults in bold)	Notes
921	Dehum Filter Reminder	<b>Off</b> 30, 60 Calendar Days 3 - 12 Calendar Months (in 1 month increments)	
1018	Vent Filter Reminder	<b>Off</b> , 3, 6, 9, 12 months	
1100	UV Devices	<b>0 - 2</b>	Some systems may have two UV devices, one for the A-Coil and another for Air Treatment. A replacement reminder can be setup for each one separately.
1105	UV Bulb 1 Reminder	<b>Off</b> , 6, 12, 24 months	
1106	UV Bulb 2 Reminder	<b>Off</b> , 6, 12, 24 months	
1401	Idle Brightness	<b>0 - Off</b> , 0 - 5	Adjust brightness of an inactive backlight (idle screen) from default 0 (backlight off) to 5 (maximum brightness). Brightness level higher than 0 will be applied and enabled for user to change in user menu only if thermostat is powered by 24 VAC (C-wire)
1410	Clock Format	<b>12 hour</b> , 24 hour	
1415	Daylight Saving	<b>On</b> , Off	Set to Off in areas that do not follow Daylight Saving Time.
1420	Temperature Offset	<b>Off</b> , -3 °F to 3 °F (in 1 °F increments) or -1.5 °C to 1.5 °C (in 0.5 °C increments)	0 °F - No difference in displayed temperature and the actual room temperature. The thermostat can display up to 3 °F (1.5 °C) lower or higher than the actual measured temperature.

# Z-Wave configuration parameters

If your gateway/hub/controller supports configuration function, you may remotely configure or change the default thermostat configuration parameters. For detailed table with all available Z-Wave configuration parameters go to <http://customer.honeywell.com> or search for **T6 Pro Z-Wave Thermostat** in the Z-Wave certified products section on <http://Z-Wavealliance.org>

## Performing a system test

You can test the system setup in **ADVANCED MENU** under **SYSTEM TEST** option.



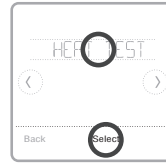
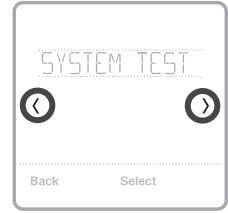

- 1 Press and hold **Menu** on the thermostat for 5 seconds to access **ADVANCED MENU** options.
- 2 Touch  or  to go to **SYSTEM TEST**.
- 3 Touch **Select** or touch text area.
- 4 Touch  or  to select system test type. Touch **Select** or touch text area.
- 5 For the heat test and cool test, use  or  to activate each stage of the equipment. For the fan test, use  or  to turn the fan on and off.

**NOTE:** The clock is used as a timer while the stages are running. The Heat On and Cool On indicators are displayed when the system test is running.



## Viewing equipment status

You can see the status of thermostat-controlled equipment in the **Menu** under the **EQMT STATUS** option.

- 1 Touch **Menu** on your thermostat.
- 2 Touch  or  to go to **EQMT STATUS**. Touch **Select** or touch text area.
- 3 Touch  or  to view statuses of all the equipment the thermostat is controlling. Depending on what feature the thermostat supports or how it was installed, the Equipment Status screen reports data for the following systems:
  - Heating and cooling
  - Fan

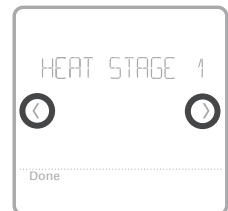
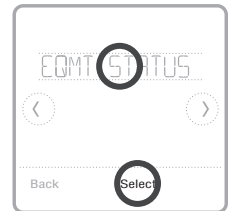

# Alerts and reminders

Alerts and reminders are displayed via the alert symbol and alert number in the clock area on the home screen. You can read more information about active alerts, snooze or dismiss non-critical alerts in Menu/Alerts.

Number	Alert/Reminder	Definition
54	Thermostat Humidity Sensor Error	The sensor of the thermostat has encountered an error. Please contact dealer to replace the thermostat.
164	Heat Pump Needs Service	Heat pump needs service. Contact dealer to diagnose and service heat pump.
170	Internal Memory Error	The memory of the thermostat has encountered an error. Please contact dealer for assistance.
171	Set the Date and Time	Set the date and time on your thermostat. The date and time are required for certain features to operate, like the program schedule.
173	Thermostat Temperature Sensor Error	The sensor of the thermostat has encountered an error. Please contact dealer to replace the thermostat.
177	Indoor Temperature Sensor Error	Wired indoor temperature sensor is not connected or there is a wiring short. Please contact dealer for assistance.
178	Outdoor Temperature Sensor Error	Wired outdoor temperature sensor is not connected or there is a wiring short. Please contact dealer for assistance.
181	Replace Air Filter (1)	Replace air filter (1). Reset the timer by touching the "dismiss" button on thermostat screen after it is replaced.
182	Replace Air Filter (2)	Replace air filter (2). Reset the timer by touching the "dismiss" button on thermostat screen after it is replaced.
184	Replace Humidifier Pad	Replace humidifier pad. Reset the timer by touching the "dismiss" button on the thermostat screen after it is replaced.
185	Replace Dehumidifier Filter	Replace the dehumidifier filter. Reset the timer by touching "dismiss" button on thermostat screen after it is replaced.
186	Clean Ventilator Core	Clean ventilator core. Reset the timer by touching the "dismiss" button on thermostat screen after it is replaced.
187	Clean or Replace Ventilator Filter	Clean or replace ventilator filter. Reset the timer by touching the "dismiss" button on thermostat screen after it is replaced.
188	Replace UV Bulb (1)	Replace UV Bulb (1). Reset the timer by touching the "dismiss" button on thermostat screen after it is replaced.

# Alerts and reminders

Number	Alert/Reminder	Definition
189	Replace UV Bulb (2)	Replace UV Bulb (2). Reset the timer by touching the "dismiss" button on thermostat screen after it is replaced.
252	AC Power Lost	If batteries used as backup power it would drain batteries quickly so Z-Wave communication needs to be turned off. The working power mode can only be changed when thermostat is NOT included in a Z-Wave network. Either to exclude and include thermostat back in to Z-Wave network to change the power mode to LSS (power-save, sleep mode) or to resume AC power. You can check the actual power mode in the thermostat <b>MENU/DEVICE INFO</b> .
405	Battery Low	Battery low. Please turn the system mode to off and replace the batteries.
407	Battery Critical	Battery critical. Thermostat cannot control your system. Please replace the batteries immediately.
546	Z-Wave Not Configured	Z-Wave has a not been configured yet to receive commands from your Z-Wave network. Please follow steps on how to include thermostat in to Z-Wave network.
547	Z-Wave Radio Error	Z-Wave module is not operating. Thermostat cannot receive commands from your Z-Wave network. Please contact dealer to replace the thermostat.

## Troubleshooting

- Screen is blank**
- Check circuit breaker and reset if necessary.
  - Make sure power switch at heating and cooling system is on.
  - Make sure furnace door is closed securely.
  - If battery powered, make sure the batteries are correctly inserted and are not dead.

- Screen is difficult to read**
- Change screen brightness in thermostat **Menu**. Increase brightness intensity for inactive backlight of the thermostat screen (max. is level 5). Setting is available only if thermostat is AC powered.

- Heating or cooling system does not respond**
- Touch **Mode** to set system to Heat. Make sure the temperature is set higher than the Inside temperature.
  - Touch **Mode** to set system to Cool. Make sure the temperature is set lower than the Inside temperature.
  - Check circuit breaker and reset if necessary.
  - Make sure power switch at heating & cooling system is on.
  - Make sure furnace door is closed securely.

- Heat runs with cooling**
- Verify there is not a wire attached to W for heat pump systems. See wiring on pages 6-7.

# Specifications

**Model Nr.:** TH6320ZW2003

**Model Name:** T6 Pro Z-Wave Thermostat

**Model Description:** Programmable Z-Wave thermostat with touchscreen

## Stages:

Up to 3 Heat / 2 Cool Heat Pump  
Up to 2 Heat / 2 Cool Conventional

## Power requirements:

Battery power: AA alkaline battery 3pcs.  
C-wire input: 18-30VAC; 50Hz-60Hz

## Electrical Ratings:

Terminal	Voltage (50/60Hz)	Running Current
W Heating (Powerpile)	18-30 Vac 750 mV DC	0.02-1.0 A 100 mA DC
W2 (Aux) Heating	18-30 Vac	0.02-1.0 A
E Emergency Heat	18-30 Vac	0.02-0.5 A
Y Compressor Stage 1	18-30 Vac	0.02-1.0 A
Y2 Compressor Stage 2	18-30 Vac	0.02-1.0 A
G Fan	18-30 Vac	0.02-0.5 A
O/B Changeover	18-30 Vac	0.02-0.5 A
L/A Input	18-30 Vac	0.02-0.5 A

**Dimension:** 4.09" x 4.09" x 1.06"

**Display size:** 6.55 sq. in.

## Temperature ranges:

Adjustable Heat Temperature Range Setting:  
40-90 °F (4.5-32.0 °C)  
Adjustable Cool Temperature Range Setting:  
50-99 °F (10.0-37.0 °C)

## Operating ambient temperature range:

37-102°F (2.78-38.89 °C)

## Temperature Sensor Accuracy:

± 1.5 °F at 70 °F (0.85 °C at 21.0 °C)

## Physical Dimensions in inches (mm) (H x W x D):

T6 PRO Z-Wave Thermostat (TH6320ZW2003):  
4-5/64 x 4-5/64 x 1-1/16 (104 x 104 x 27)  
UWP Mounting System (included):  
2-9/32 x 2-13/64 x 2-43/64 (58 x 56 x 10)  
Standard Installation Adapter (included):  
3-29/32 x 3-57/64 x 21/32 (99 x 99 x 17)  
Decorative Cover Plate – Small (included):  
4-49/64 x 4-49/64 x 11/32 (121 x 121 x 9)  
Decorative Cover Plate – Large (THP2400A1068):  
6-7/64 x 6-7/64 x 9/32 (155 x 155 x 7)

## Z-Wave Radio:

Frequency (USA and Canada): 908.42 MHz  
Certified: Z-Wave Plus  
Generic Device Type: Thermostat  
Node type (C-wire): Always On Slave (AOS)  
Node type (Battery): Listening Sleeping Slave (LSS)  
Z-Wave Chipset: ZM5202AU

## Supported Z-Wave Command Classes:

Z-Wave Plus Info V2  
Supervision V1  
Transport Service V2  
Association V2  
Version V2  
Association Group Information V2  
Basic V1  
Battery V1  
Clock V1  
Configuration V4  
Device Reset Local V1  
Manufacturer Specific V2  
Sensor Multilevel V5  
Notification V3  
Powerlevel V1  
Security 2 V1  
Thermostat Fan Mode V3  
Thermostat Fan State V1  
Thermostat Mode V3  
Thermostat Operating State V1  
Thermostat Setpoint V2

## NOTES:

### Thermostat Mode V3:

- Some of the reported modes are manufacturer specific if not covered by the Z-Wave command class.

### Basic V1 (basic set command implementation):

- Value 0x00 Device goes to Energy saving setting (AWAY mode)
- Values 0x01-0x63 and 0xFF Device goes to Comfort setting (HOME mode)

### Notification V3:

- Notification V3 is enabled by default (Power management alarm handling). Notification Type: Power Management (0x08). Notification Events: AC mains disconnected (0x02), AC mains re-connected (0x03).

### Security:

- All supported Z-Wave Command classes are supported securely (S2 unauthenticated), except Transport Service V2, Security 2 V1 and Z-Wave Plus Info V2

### Association V2:

- Group ID: 1; Maximum Nodes: 1; Description: Z-Wave Plus Lifeline
- Command Classes reported: Multilevel Sensor, Thermostat Setpoint, Thermostat Mode
- Thermostat Fan Mode, Thermostat Operating State, Thermostat Fan State, Basic



**CAUTION: ELECTRICAL HAZARD**

Can cause electrical shock or equipment damage. Disconnect power before beginning installation.

**CAUTION: EQUIPMENT DAMAGE HAZARD**

Compressor protection is bypassed during testing. To prevent equipment damage, avoid cycling the compressor quickly.

**CAUTION: MERCURY NOTICE**

If this product is replacing a control that contains mercury in a sealed tube, do not place the old control in the trash. Contact your local waste management authority for instructions regarding recycling and proper disposal.

## 5-year limited warranty

For Warranty information go to <http://customer.honeywell.com>

## Regulatory information

**FCC REGULATIONS****§ 15.19 (a)(3)**

This device complies with part 15 of the FCC Rules.

Operation is subject to the following two conditions:

- 1 This device may not cause harmful interference, and
- 2 This device must accept any interference received, including interference that may cause undesired operation.

**IC REGULATIONS****RSS-GEN**

This device complies with Industry Canada's license-exempt RSSs.

Operation is subject to the following two conditions:

- 1 This device may not cause interference; and
- 2 This device must accept any interference, including interference that may cause undesired operation of the device.

**FCC Warning (Part 15.21) (USA only)**

Changes or modifications not expressly approved by the party responsible for compliance could void the user's authority to operate the equipment.

### Home and Building Technologies

In the U.S.:

Honeywell

715 Peachtree Street NE

Atlanta, GA 30308

<http://customer.honeywell.com>

\* U.S. Registered Trademark.

© 2017 Honeywell International Inc.

33-00294-02 M.S. 09-17

Printed in Czech Republic