



# ***PS Series Inverter/Chargers***

## ***AE Configuration - Revision 5 Software***

# ***Owner's Manual***

---

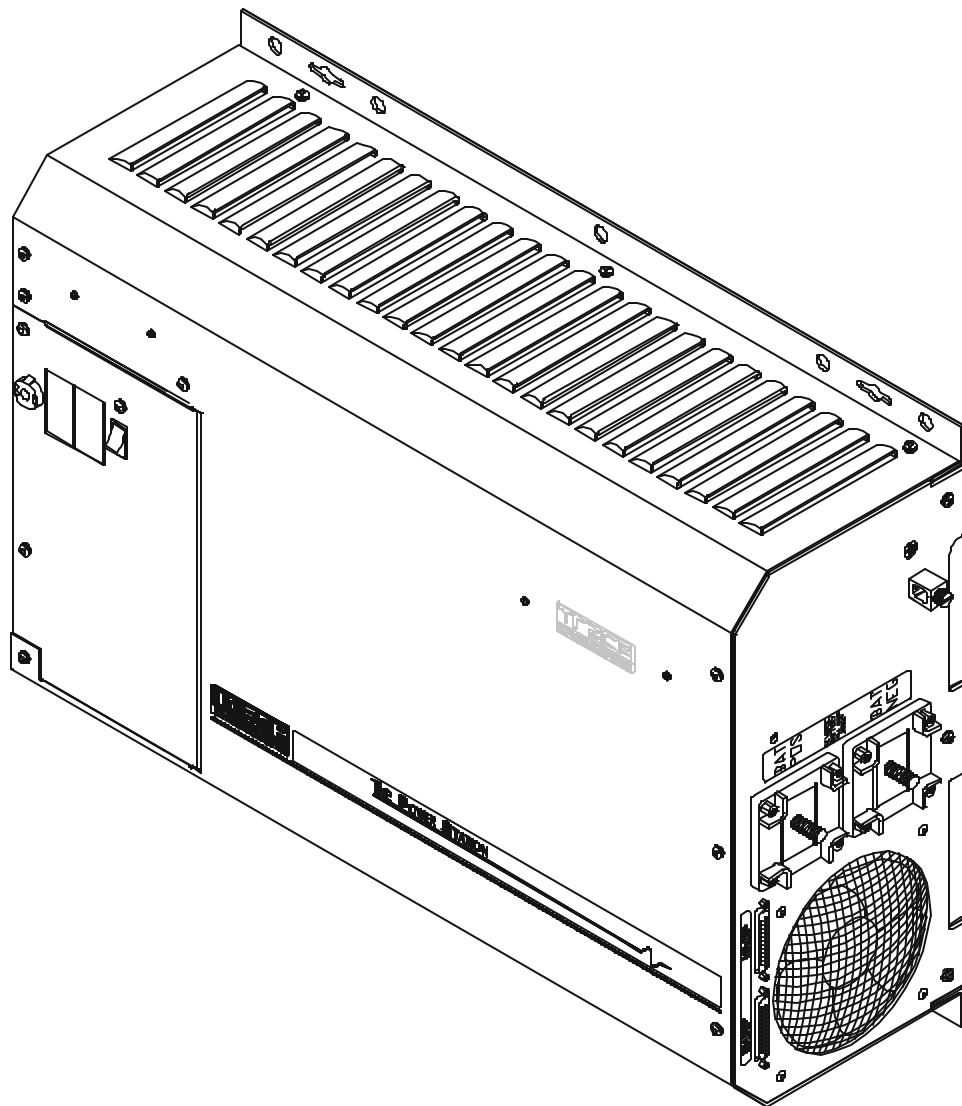

INSIDE  
FRONT  
COVER

**TABLE OF CONTENTS**

**IMPORTANT SAFETY INSTRUCTIONS ..... 3**

    GENERAL PRECAUTIONS ..... 3

    SPECIAL NOTICES ..... 3

    PERSONAL PRECAUTIONS ..... 4

**INTRODUCTION ..... 5**

**UNIT IDENTIFICATION ..... 7**

    MODEL NUMBER ..... 8

    CERTIFICATION ..... 8

**CONTROLS, INDICATORS AND COMPONENTS ..... 9**

    ON/OFF POWER SWITCH ..... 9

    INVERTER/CHARGER CIRCUIT BREAKER ..... 10

    CIRCUIT BREAKERS ..... 10

    'MAXIMUM AC AMPS IN' SWITCH ..... 10

    LED STATUS INDICATORS ..... 10

    AC SIDE ..... 13

    DC SIDE ..... 15

**INSTALLATION ..... 17**

    LOCATION ..... 17

    MOUNTING ..... 18

    VENTILATION ..... 18

    AC WIRING ..... 18

    DC WIRING ..... 21

    QUICK INSTALL ..... 26

**FUNCTIONAL TEST ..... 27**

**MENU SYSTEM ..... 29**

    OVERVIEW ..... 29

    USER MENU MAP ..... 30

    SETUP MENU MAP ..... 31

    SWRC REMOTE CONTROL ..... 32

    USER MENU ..... 35

    SETUP MENU ..... 44

**OPERATION ..... 55**

    THEORY OF OPERATION ..... 55

    POWER VS. EFFICIENCY ..... 56

    INVERTER CAPACITY VS TEMPERATURE ..... 57

    OPERATING MODES ..... 58

    INVERTER MODE ..... 59

    CHARGER MODE ..... 62

    INVERTER/CHARGER MODE ..... 68

    GENERATOR SUPPORT MODE ..... 70

    AUTOMATIC GENERATOR CONTROL MODE ..... 72

    UTILITY BACK-UP MODE ..... 80

    UTILITY INTER-ACTIVE MODE ..... 82

    ENERGY MANAGEMENT MODES ..... 89

    USING MULTIPLE INVERTERS ..... 92

**TECHNICAL INFORMATION ..... 95**

    BATTERIES ..... 95

    APPLICATIONS ..... 108

    TROUBLESHOOTING GUIDE ..... 109

    INVERTER/CHARGER TERMINOLOGY ..... 114

    SPECIFICATIONS AND FEATURES ..... 117

    DIMENSIONS ..... 118

    INSTALLATION DIAGRAMS ..... 120

    USER SETTINGS WORKSHEET ..... 122

**APPENDIX ..... 127**

    OPTIONS ..... 127

    OTHER PRODUCTS ..... 129

# TABLE OF CONTENTS

REFERENCE TABLES & GRAPHS.....	130
<b>WARRANTY/REPAIR INFORMATION.....</b>	<b>133</b>
LIMITED WARRANTY.....	133
WARRANTY REGISTRATION.....	133
LIFE SUPPORT POLICY.....	133
WARRANTY OR REPAIR SERVICE REQUIRED.....	134
<b>INDEX.....</b>	<b>135</b>

## INDEX OF FIGURES

Figure 1, Identification Label.....	7
Figure 2, Certification Label.....	8
Figure 3, Inverter Controls and Indicators.....	9
Figure 4, 'Maximum AC Amps In' Switch And LED Status Indicators.....	10
Figure 5, PS Series AC Side.....	13
Figure 6, AC Circuit Board.....	13
Figure 7, AC Terminal Block.....	14
Figure 8, AC Ground Terminal.....	14
Figure 9, PS Series DC Side.....	15
Figure 10, Airflow Intake Location.....	18
Figure 11, AC Wire Connections.....	19
Figure 12, Warning Label.....	21
Figure 13, Battery to Inverter Cable Connection.....	23
Figure 14, Multiple Point Ground System.....	25
Figure 15, Single Point Ground System.....	25
Figure 16, SWRC (Remote Control).....	32
Figure 17, Trace PS Series Inverter/Charger Simple Block Diagram.....	55
Figure 18, Trace PS Series Inverter/Charger Output Waveform.....	56
Figure 19, Inverter Capacity vs. Temperature.....	57
Figure 20, Three-Stage Battery Charging.....	62
Figure 21, BTS (Battery Temperature Sensor).....	63
Figure 22, Relay RY7 and RY8 Sequence.....	75
Figure 23, Two-Wire Start Wiring Diagram.....	76
Figure 24, Three Wire Start Wiring Diagram (HONDA Type).....	77
Figure 25, Three Wire Start Wiring Diagram (ONAN Type).....	77
Figure 26, Selling Power from a DC Charging Source; Hypothetical Time of Day Operational History.....	84
Figure 27, Selling Power Stored in the Batteries; Hypothetical Time of Day Operational History.....	85
Figure 28, Utility Interactive Line-Tie System with Battery Backup (120VAC models).....	87
Figure 29, Overvoltage Protection for Battery.....	88
Figure 30, Series Configuration: 6-Volt Battery Wiring.....	104
Figure 31, Series Configuration: 12-Volt Battery Wiring.....	104
Figure 32, Parallel Configuration: 12-Volt Battery Wiring.....	105
Figure 33, Series-Parallel Configuration: 6-Volt Battery Wiring.....	106
Figure 34, Series-Parallel Configuration: 12-Volt Battery Wiring.....	106
Figure 35, AC Waveforms.....	115
Figure 36, PS Series Dimensions.....	118
Figure 37, PS Series Bottom Plate Mounting Dimensions.....	119
Figure 38, PS Series – Showing Knockout Sizes for AC Wiring.....	119
Figure 39, PS Series Installation Diagram – Stationary Backup System.....	120
Figure 40, PS Series Installation Schematic.....	121
Figure 41, AWG Wire Size.....	131

## INDEX OF TABLES

Table 1, Recommended Minimum AC Wire Sizes To Breaker/Fuse Size at 75° C.....	19
Table 2, Minimum Recommended Battery Cable Size Vs. Cable Length.....	21
Table 3, Battery Cable to Maximum Breaker/Fuse Size.....	22
Table 4, AC Input Default Settings.....	64
Table 5, Battery Charger Default Settings.....	65
Table 6, Charging Setpoints for Common Battery Types.....	66
Table 7, Typical Wattage of Common Appliances.....	100
Table 8, Battery Charging: Charging Setpoints.....	101
Table 9, Battery State of Charge Voltage Table.....	102
Table 10, Battery Cable Inductance.....	107
Table 11, Typical Power Consumption of Common Appliances.....	130
Table 12, AWG to Metric Wire Conversion Chart.....	130
Table 13, Battery Cable to Maximum Breaker/Fuse Size.....	131
Table 14, AC Input Default Settings.....	131
Table 15, Battery Charger Default Settings.....	132
Table 16, Minimum Recommended Battery Cable Size Vs. Cable Length.....	132
Table 17, Recommended Minimum AC Wire Sizes (75° C).....	132
Table 18, Safety Ground Wire Size Table.....	132

## IMPORTANT SAFETY INSTRUCTIONS

### SAVE THESE INSTRUCTIONS!

This manual contains important safety and operating instructions as prescribed by UL Standards for the Trace Engineering PS Series Inverter/Chargers for use in residential and commercial applications. This manual specifically covers products with the revision 5.\* (\* refers to all revisions from 5.0 to 5.9) software.

### GENERAL PRECAUTIONS

1. Before using the PS Series Inverter/Charger, read all instructions and cautionary markings on:
  - (a) the inverter/charger;
  - (b) the batteries and;
  - (c) all appropriate sections of this manual.
2. **CAUTION** - To reduce risk of injury, charge only deep-cycle lead acid, lead antimony, lead calcium, gel cell, absorbed glass mat, or NiCad/NiFe type rechargeable batteries. Other types of batteries may burst, causing personal injury and damage.
3. Do not expose inverter/charger to rain, snow or liquids of any type. The inverter is designed for indoor mounting only. Protect the inverter from splashing if used in vehicle applications.
4. Use of an attachment not recommended or sold by Trace Engineering for the PS Series Inverter/Charger may result in a risk of fire, electric shock, or injury to persons.
5. Do not disassemble the inverter/charger. Take it to a qualified service center when service or repair is required. Incorrect re-assembly may result in a risk of electric shock or fire.
6. To reduce risk of electric shock, disconnect all wiring before attempting any maintenance or cleaning. Turning off the inverter will not reduce this risk. Solar modules produce power when exposed to light. Cover them with opaque material before servicing any connected equipment.
7. **WARNING – RISK OF EXPLOSIVE GASSES**
  - (a) **WORKING IN VICINITY OF A LEAD ACID BATTERY IS DANGEROUS. BATTERIES GENERATE EXPLOSIVE GASSES DURING NORMAL BATTERY OPERATION. FOR THIS REASON, IT IS OF UTMOST IMPORTANCE THAT EACH TIME BEFORE SERVICING EQUIPMENT IN THE VICINITY OF THE BATTERY, YOU READ THIS MANUAL AND FOLLOW THE INSTRUCTIONS EXACTLY.**
  - (b) To reduce risk of battery explosion, follow these instructions and those published by the battery manufacturer and manufacturer of any equipment you intend to use in the vicinity of the battery. Review cautionary markings on these products and on engine.

### SPECIAL NOTICES

1. Tools required to make AC and DC wiring connections: Wire strippers; 1/2" (13MM) open-end or socket wrench; Phillips #2 screwdriver; flat blade 1/4" (6MM) screwdriver.
2. No terminals or lugs are required for hook-up of the AC wiring. AC wiring must be copper wire and rated for 75°C or higher. The maximum wire size for the AC terminals is #6 AWG (4.11 mm diameter). Battery cables must be rated for 75°C or higher. Crimped and sealed copper ring terminal lugs with a 5/16 hole should be used to connect the battery cables to the DC terminals of the inverter/charger. Soldered cable lugs are also acceptable.
3. Torque all AC wiring connections to 20 inch-pounds. Torque all DC cable connections to 10-15 foot-pounds. Be extra cautious to reduce the risk of dropping a metal tool onto batteries. It could short-circuit the batteries or other electrical parts resulting in sparks that could cause an explosion.
4. This inverter/charger is intended to be used with a battery supply with a nominal voltage that matches the last two digits of the model number, e.g. 12-Volt with a PS2512.
5. For instructions on mounting, see the **MOUNTING** section on page 18 of this manual.

# IMPORTANT SAFETY INSTRUCTIONS

---

6. **NOTE:** Do not use the keyhole mounting slots for permanent installations. For battery installation and maintenance read the battery manufacturer's installation and maintenance instructions prior to operating.
7. No AC or DC disconnects are provided as an integral part of this inverter. Both AC and DC disconnects must be provided as part of the system installation. Refer to the **INSTALLATION** section beginning on page 17 for more information.
8. No overcurrent protection for the battery supply is provided as an integral part of this inverter. Overcurrent protection of the battery cables must be provided as part of the system installation. Refer to the **INSTALLATION** section beginning on page 17 and the **DC DISCONNECT AND OVERCURRENT PROTECTION** section on page 21 for more information.
9. No over current protection for the AC output wiring is provided as an integral part of this inverter. Overcurrent protection of the AC output wiring must be provided as part of the system installation. Refer to the **INSTALLATION** section beginning on page 17 and the AC WIRING section on page 18 for more information.
10. The AC output neutral conductor and DC negative conductors are not connected (bonded) to the inverter chassis. Both the input and output conductors are isolated from the enclosure and each other. System grounding, if required by sections 690-40, and 690-42 of the National Electric Code, ANSI/NFPA 70-1996, is the responsibility of the system installer. All installations must comply with local and national electrical codes and standards.
11. **GROUNDING INSTRUCTIONS** - This inverter/battery charger should be connected to a grounded, permanent wiring system. For most installations, the negative battery conductor should be bonded to the grounding system at one (and only one point) in the system. All installations should comply with national and local codes and ordinances. Refer to the **SYSTEM GROUNDING** section on page 24 for more information.

## PERSONAL PRECAUTIONS

1. Someone should be within range of your voice or close enough to come to your aid when you work near batteries.
2. Have plenty of fresh water and soap nearby in case battery acid contacts skin, clothing, or eyes.
3. Wear complete eye protection and clothing protection. Avoid touching eyes while working near batteries. Wash your hands when done.
4. If battery acid contacts skin or clothing, wash immediately with soap and water. If acid enters eye, immediately flood eye with running cool water for at least 15 minutes and get medical attention immediately.
  - (a) Baking soda neutralizes lead acid battery electrolyte.
  - (b) Vinegar neutralizes spilled NiCad and NiFe battery electrolyte.
  - (c) Keep a supply on hand in the area of the batteries.
5. **NEVER** smoke or allow a spark or flame in vicinity of a battery or generator.
6. Be extra cautious to reduce the risk of dropping a metal tool onto batteries. It could short-circuit the batteries or other electrical parts that may result in a spark which could cause an explosion.
7. Remove personal metal items such as rings, bracelets, necklaces, and watches when working with a battery. A battery can produce a short-circuit current high enough to weld a ring or the like to metal, causing severe burns.
8. **NEVER** charge a frozen battery.
9. If necessary to remove the battery, make sure all accessories are off. Then, remove the grounded terminal from the battery first.
10. If a remote or automatic generator start system is used, disable the automatic starting circuit and/or disconnect the generator from its starting battery while performing maintenance to prevent accidental starting.

## INTRODUCTION

Congratulations! You are the proud owner of the finest inverter on the market today - and one very complex piece of equipment. The Trace Engineering PS Series Inverter/Charger has many features and capabilities previously either non-existent, or found only in separate products.

With proper installation, the inverter will operate satisfactorily for many applications straight out of the box using the factory default settings. To fully utilize the inverter's generator inter-active, or utility inter-active capabilities, it is necessary to understand the way the inverter operates and then tailor its operation via the SWRC and the user and setup menu systems. This manual will provide the necessary information. However, it is recommended that you consult with your authorized dealer to ensure correct installation and maximum utilization of the numerous features of this product. If you do not understand any aspect of the installation, contact your authorized dealer/installer for assistance.

If you intend to operate the inverter in a utility inter-active mode in which power will be sold to the utility, you must contact the local utility office and get their approval. The utility may require additional information that may not be included in this manual. Please contact your Trace Engineering dealer/installer for assistance.

This manual is specific to models designed for use in Alternative Energy or Back-Up Power systems in permanent structures, such as homes and commercial buildings. As a minimum, you should read the sections of the manual that relate to your type of installation. The **MENU SYSTEM** section, beginning on page 29, explains how to make changes to the inverter's user/setup menus. The **OPERATION** section, beginning on page 55, explains how the inverter works in each of its different modes. Focus on the Operating Modes that relate best to your type of installation and make the appropriate selections and adjustments. Installation diagrams are provided for many of the various applications. This menu system provides control of the inverter, allows features to be enabled, and allows setting of operating parameters.

This is a long manual and much of it is technical. Throughout the manual terms may be used that are unfamiliar, see the **INVERTER/CHARGER TERMINOLOGY** glossary on page 114 for clarification. If you are an insomniac, properly used, this manual is guaranteed to provide several good nights of sleep.

**This manual is specific to REVISION 5\* PS AE software.** Using the optional **SWRC** Remote Control, you can verify what revision software your inverter is using by selecting third menu item under the **TRACE ENGINEERING (3)** menu heading.

*Note: \* refers to all revisions from 5.0 to 5.9*

Before beginning -

- Unpack the inverter/charger and verify that you have the correct inverter.
- Record your model number and serial number below for future reference
- Verify that you have everything listed on the Packaging Checklist sheet included in your box. If any items are missing, please call Customer Service at (360) 435-8826.
- Complete the warranty card and mail it to Trace Engineering within 10 days from the date of purchase **Keep your bill of sale** as proof of purchase, should any difficulties arise concerning the registration of the warranty card.
- Keep the original carton and packing materials. It is the best way to keep the inverter safe if it needs to be moved.
- Read this manual and enjoy your inverter/charger!

Model Number: \_\_\_\_\_

Serial Number: \_\_\_\_\_

Check out our web site at [www.traceengineering.com](http://www.traceengineering.com) for more information and answers to your FAQ's

**PAGE  
INTENTIONALLY  
NOT USED**



## UNIT IDENTIFICATION

This section describes the marking and location of the model and serial number for the PS Series Inverter/Chargers. Use this section to determine the type and model of your inverter/charger. The unit identification label on the left side panel of the inverter/charger will show the model number, serial number, DC charging current (maximum and default setting), AC voltage and frequency, configuration, and date of manufacture.

Note: Ensure you have entered your serial number and model number on page 5 for future reference.

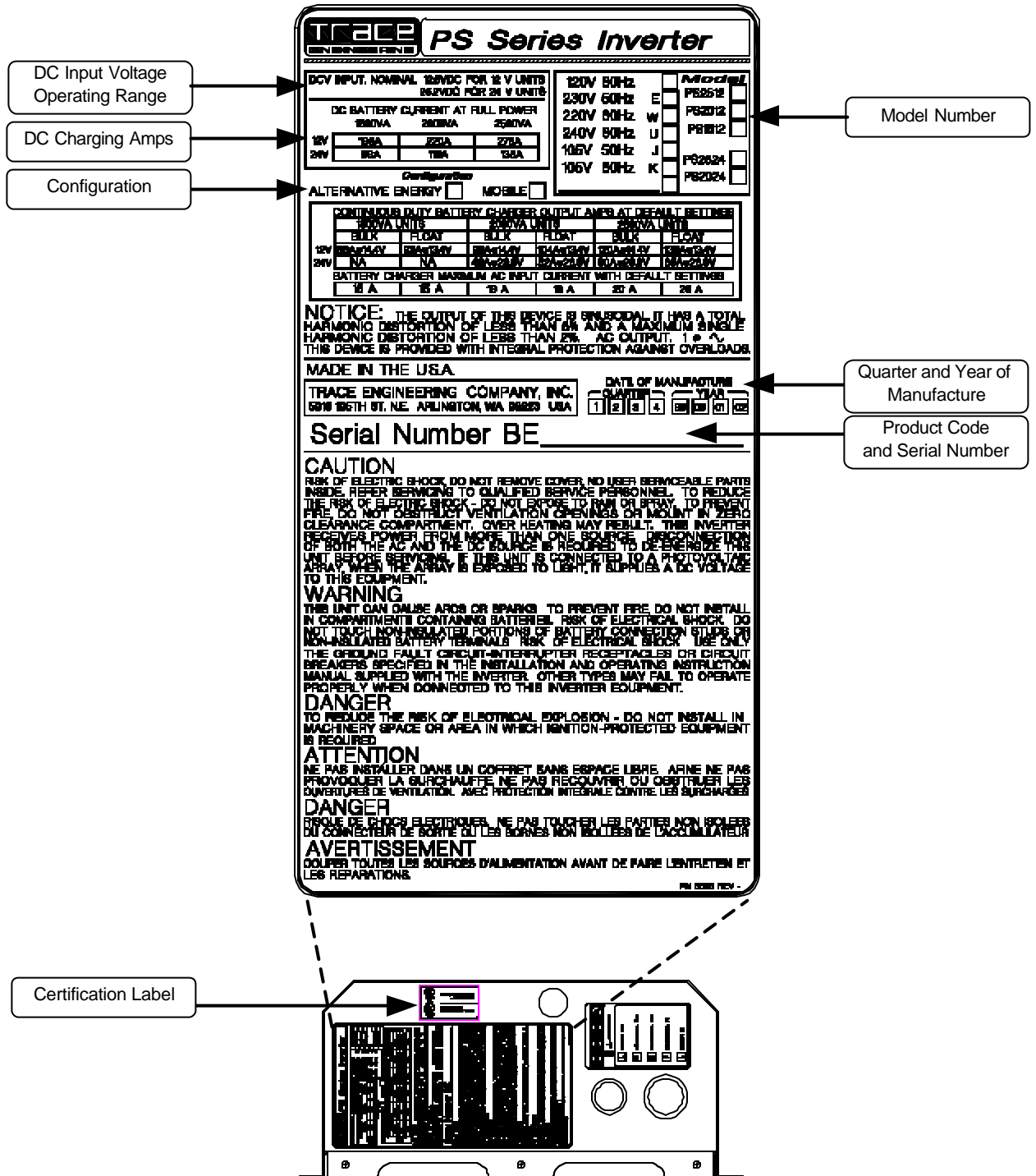

Figure 1, Identification Label

# CONTROLS, INDICATORS AND COMPONENTS

## MODEL NUMBER

The model Number of your inverter determines the different features your unit may have. Consider the following unit with a **PS2512** model number:

<b>PS</b>	<b>25</b>	<b>12</b>	<b>*</b>
<i>Model</i>	<i>Power</i>	<i>Nominal DC Voltage</i>	<i>AC Voltage/Options</i>

**Model:** The first letter(s) indicate the model, in this case the **PS Series**.

**Power:** The first and second positions in the Model Number indicate the continuous AC power output in hundreds of VA (Volt-Amps). Power levels available start at 1800 up to 2500 Volt-Amps with different DC voltages. In the example above, **25** would stand for a 2500 VA (2.5 kVA) continuous-output inverter.

**DC Voltage (Input and Output):** The number (**12**) following the *Power* rating indicates the nominal battery voltage this inverter/charger requires. The inverter/charger uses this battery voltage to convert to an AC voltage output, and charge the batteries that are connected when powered by the same AC voltage. The number (**24**) indicates a 24v inverter/charger

**AC voltage/Options:** The letter(s) following the *DC Voltage* rating indicate the particular configuration or particular option (s) this inverter/charger is specifically designed to provide. See the **SPECIFICATIONS AND FEATURES** section on page 117 for the different voltage and frequency models available.

### Configuration:

**AE:** These models are designed for use in Alternative Energy or Back-Up Power systems in permanent structures such as homes and commercial buildings. These units are used where the neutral is required to be "polarized" (or connected) permanently to the safety ground at the AC panel.

**MOBILE:** These models are designed for use in mobile (RV/Marine) applications. They feature 120 VAC, 60 Hz output and employ automatic ground-to-neutral switching which "polarizes" the inverter's AC output when operating in Inverter mode and allows the external AC source to "polarize" the neutral when the inverter is in Charge mode.

## CERTIFICATION

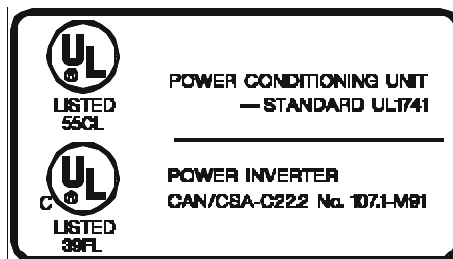

Figure 2, Certification Label

The 120 VAC/60 Hertz models of the PS Series Inverter/Chargers (AE Configured) are Listed to *UL Standard 1741, Power Conditioning Units for use in Residential and Commercial Photovoltaic Power Systems*. This label is your guarantee that this inverter/charger has been tested by UL to nationally recognized Safety Standards and found to be free from reasonably foreseeable risk of fire, electric shock and related hazards. These units are also Listed to *CAN/CSA-22.2 No. 107.1-M91*, which means these models have been evaluated to Canadian safety requirements, which may be somewhat different from U.S. safety requirements.

This inverter/charger is intended to be installed in a residential or commercial application. This unit should not be installed in an application for which it is not listed (i.e. Land Vehicles or Marine Craft). The inverter may not be damaged; however, it would not comply with safety code requirements and may cause other problems. .

## CONTROLS, INDICATORS AND COMPONENTS

Shown below are the controls and indicators on the PS Series Inverter/Charger. They enable you to control and monitor the operating mode and system status of your inverter/charger. The controls on the PS Series Inverter/Chargers are very straightforward. They feature a momentary On/Off Power switch, an inverting/charger circuit breaker, four LED status indicators, a two-position switch for determining maximum AC input current level and connecting ports for other optional accessories.

The figure below shows the location of the different controls and the Status Indicators.

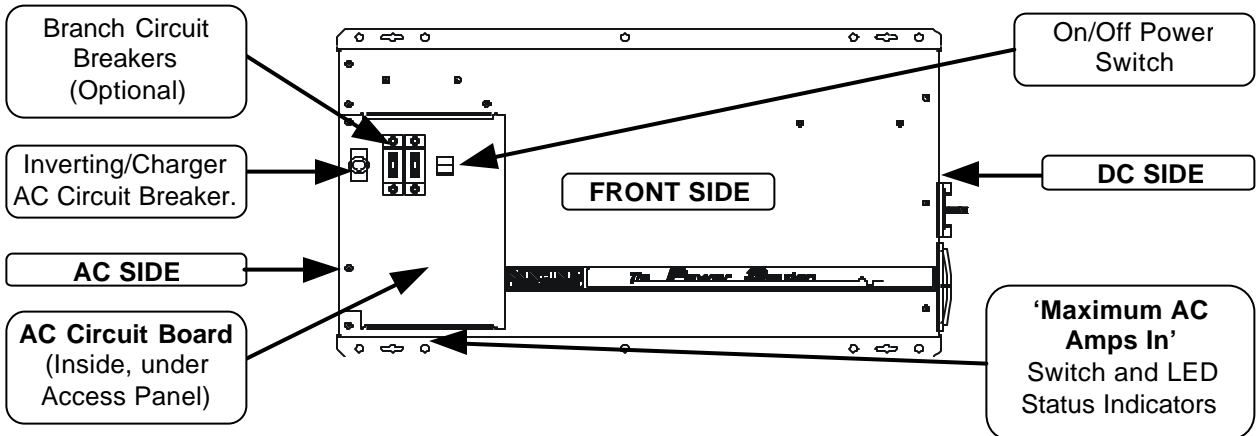
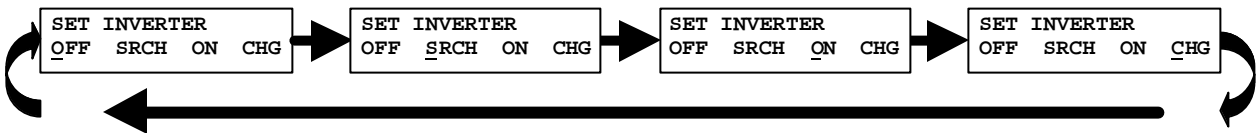

Figure 3, Inverter Controls and Indicators

### ON/OFF POWER SWITCH



This switch allows turning the inverter **ON** and **OFF**, enabling the **SEARCH** mode or selecting the charger only mode **CHG**. The on/off button also resets the inverter in the event it shuts down completely due to a fault condition. The inverter always starts in the **OFF** position when powered up. Each push changes the mode you are in, continue pressing the **ON/OFF** power switch until you have your desired selection. Monitor the **INVERT** (yellow) LED to determine what mode you have selected.

- **OFF: Disables the inverter.** This is the default position of the inverter upon power-up. When the **OFF position is selected, no power will be provided to the AC loads even if an AC source is available.** The red **ERROR** LED will be on, this indicates that there is no AC available on the output and the **INVERT** (yellow) LED will be off.
- **SRCH: Enables the automatic load search mode control system.** This system will turn on the inverter if a large enough load is connected. If not enough AC loads are detected, the **INVERT** (yellow) LED will blink slowly (one blink/sec). No power will be provided to the AC loads, even if an AC source is available. The sensitivity threshold is defaulted to 48 watts.
- **ON:** Allows the inverter to provide AC voltage to the output and energize the AC loads either from the battery or from any "synchronized" AC source available on the input. The **INVERT** (yellow) LED will be on.
- **CHG:** Allows the inverter to operate only as a battery charger. AC power will be available to the AC loads only if an AC source is available and "synchronized". This mode is used to prevent discharge of the batteries by the AC loads when a utility outage occurs. The **INVERT** (yellow) LED will double blink each second (double blink/sec) to indicate that you are in **CHG** mode. This mode is only available when the **SET GRID USAGE** menu item is in the **FLT** mode under the **INVERTER SETUP (9)** menu heading. When a different mode is selected, this position will be locked out and it will be necessary to use the **SET POINTS** buttons on the optional SWRC remote to move the cursor. Selecting the **CHG** mode disables the Automatic Generator Start features.

# CONTROLS, INDICATORS AND COMPONENTS

## INVERTER/CHARGER CIRCUIT BREAKER

This circuit breaker protects the unit's internal wiring while the unit is inverting or charging. It is not used for the pass-through current, which is rated for 50 amps AC. This is not a branch circuit rated breaker, output breakers are required. Press the breaker to reset.

## CIRCUIT BREAKERS

An optional, field installable, *Breaker Kit* can be ordered which will allow direct hook-up up of up to two circuits without the use of a separate sub-panel. The *Breaker Kit* is available with a single 15 or 20 amp branch circuit rated breaker.

## 'MAXIMUM AC AMPS IN' SWITCH

This switch determines the AC current level at which the inverter begins to back-off the battery charger or operates in parallel to reduce the load on a generator. This prevents the overloading of the AC source and prevents nuisance tripping of the AC source circuit breakers. Typically, this is set to the size of the AC source's (Utility Power or Generator) circuit breaker feeding the inverter or the maximum output amperage ability of the AC source.

The switch can be switched to the AC1 side to limit the input current to 50 Amps or to the AC2 side to limit the input current to 30 amps.

The maximum AC input amp size can be adjusted to different settings in the **SET GRID (AC1) AMPS AC** and the **SET GEN (AC2) AMPS AC** menu items using the optional SWRC remote.

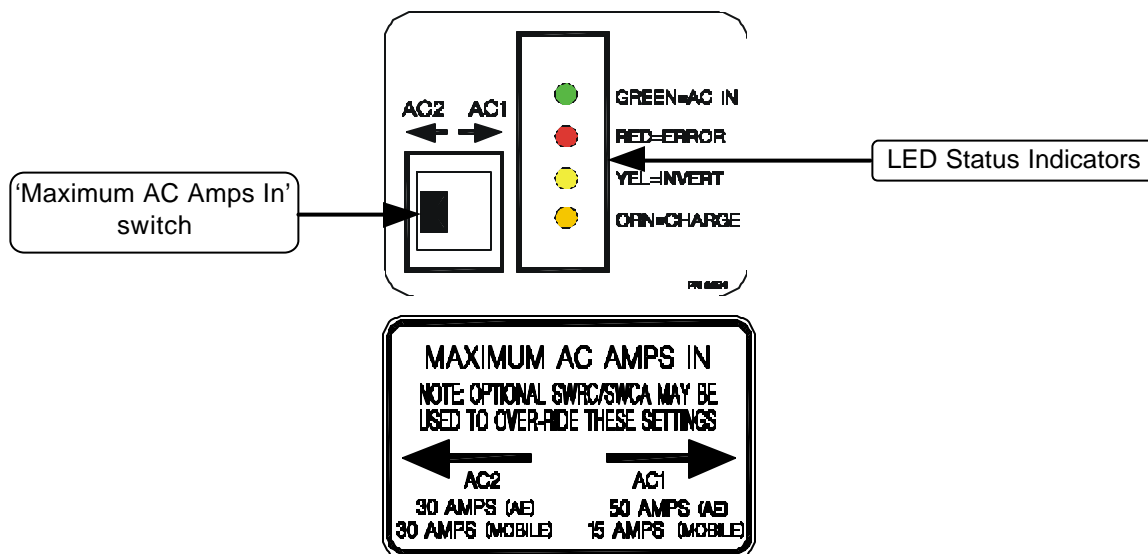

Figure 4, 'Maximum AC Amps In' Switch And LED Status Indicators

## LED STATUS INDICATORS

All PS Series Inverter/Chargers feature four LED status indicators - located on the unit's front side panel - that will enable you to monitor the operating mode and system status of your inverter/charger by lighting one or more of the LED's. The different colored LED's will light based on the condition or operating mode of the inverter/charger. Refer to the LED colors below to determine you unit's status.

### GREEN = AC IN

**ON:** An AC source has been applied to the AC input terminals of the inverter. When an AC source is connected to the input terminals the green LED indicator will come on. After a delay period has passed and once synchronized, the inverter will close an internal relay to connect the AC source to the AC loads and the inverter will begin to charge the battery and the orange LED indicator will turn solid.

## RED = ERROR

**ON:** Indicates that there is no AC voltage available on the output. The red error LED is used in conjunction with the yellow (invert) LED to determine the operating mode of the inverter. If the red LED is on and the yellow (invert) LED is off, then the inverter is in standby (DC power connected but not turned on) and is ready to turn on. With the red LED on and the yellow LED blinking twice a second with a one second pause, then the inverter is in the CHG (charge only) mode and waiting for AC to be connected to the input. If the red LED is on and the yellow (invert) LED is flashing rapidly (4 times/second), this indicates that an error condition exists. Refer to the **INVERT** (yellow) LED for more information on error causes.

## YELLOW = INVERT

**OFF – INVERTER/CHARGER IS OFF:** The inverter is off and not operational. This is the default position of the inverter upon power-up. No AC output is available.

**ON – INVERTER/CHARGER ON:** The inverter is operational and AC output is available. Inverter is providing AC power from the batteries or the input AC source is providing pass-thru power to the output.

**ONE BLINK/SEC – SEARCH:** The yellow LED will blink once each second to indicate the inverter is in search mode and is looking for an AC load greater than the **SEARCH WATTS** setting (*default = 16 watts*).

**DOUBLE BLINK/SEC – CHARGE ONLY MODE (CHG):** The yellow LED will double blink then pause for a second to indicate that the unit is in *Charge Only* mode.

**RAPID BLINK (4/SEC) – ERROR MODE:** The yellow LED will blink rapidly to indicate that an operating error has occurred. This can be caused by over-load or over-current, over-temperature (transformer or heatsink), high or low battery voltage, AC source wired to the output, or an external (stacked) error. When the inverter senses one of these situations, it may protect itself by disconnecting from the loads. There are also advisory and numerous generator-related errors that will not disconnect the AC loads. Refer to each error cause below to help determine your particular error cause.

### ERROR CAUSES (AC OUTPUT WILL BE DISCONNECTED):

If an over-current condition exists, the inverter will shutdown and must be reset with the power button. If the error condition is based on over-temperature (transformer or heatsink), or high or low battery voltage the error protection circuitry resets automatically.

**Low Battery voltage:** Your battery voltage is below the **LOW BATTERY CUT OUT (LBCO) VDC** setting and the inverter has shut off to prevent over-discharge of the battery. Allow the battery to recharge or connect to an AC source such as a back-up generator. The inverter will reset when the battery exceeds the LBCO setting.

**Low inverter voltage:** Your inverter/charger monitors the minimum AC voltage level of the AC output. This assures a continuous supply of quality Alternating Current to your electrical loads. The inverter AC output voltage level is determined by the **SET INPUT LOWER LIMIT VAC** setting. If the AC voltage falls below this setting continuously for 32 seconds the inverter disconnects from the loads and turns on the error LED. The cause for this error could be high battery voltage or an excessively large load.

**High Battery voltage:** The inverter turns off due to a high battery voltage condition determined by the **HBCO (HIGH BATTERY CUT-OUT)** setting. This can be caused by the solar array or other charging source not being regulated. Check the controller for proper operation. Some controllers have a “equalize” setting which over-rides the normal operation, allowing the battery voltage to be unregulated. Return the controller to the “normal” setting and check for proper operation. If you are using NiCad type batteries, you will need to increase the **HBCO** setting. The inverter will automatically reset once the battery voltage has dropped 1.5 volts below the **HBCO** setting.

**Over-temperature (Transformer or Heatsink) :** The transformer or power transistors have exceeded their safe operating temperature and the inverter has turned off. When operating as a battery charger, the inverter will reduce its charging rate to prevent overheating. As an inverter, overheating can be caused by attempting to operate too large of a load for too long, a failure of the inverter cooling fans, or that the air flow into or out of the inverter is being blocked. The inverter will automatically reset once it has cooled. While the inverter has shut down, AC power from any AC source may not continue to pass through the inverter to power AC loads. Any power management provided by the inverter will not be able to occur while the inverter is off.

# CONTROLS, INDICATORS AND COMPONENTS

---

**Over-current:** The load requirement has exceeded the maximum output AC amps. To clear this fault, disconnect the loads and restart the inverter. To restart the inverter after an overcurrent fault condition, press the On/Off Power Switch only one time. Reconnect the loads one at a time to find the load or combination of loads that caused the problem. If the inverter will not restart with all the AC loads disconnected, remove all AC wiring from the terminal block and try to restart again. If it restarts, the problem is with the wiring. If it does not restart, refer to the other error causes to determine the error.

**AC source wired to output:** Reports that an AC voltage source was connected directly to the AC output. This can be caused by improper wiring or incorrect installation of the inverter. This condition is much worse than a short circuit and may cause damage to the inverter. Disconnect all wiring from the AC input and output to find the cause. After the cause has been found and corrected, you can restart the inverter by selecting **OFF** and then **ON** or **SRCH** with the On/Off Power Switch

**External error (stacked):** A problem has occurred with the series interface cable or one of the inverters operated in series. Check the cable for damage and replace it to see if the problem is corrected. Also, check the connecting input and output AC wiring.

## ERROR CAUSES (WILL NOT CAUSE AC OUTPUT TO BE DISCONNECTED).

**Low AC input voltage:** Your inverter/charger monitors single cycle voltage problems from the AC source. The low AC voltage level is determined by the **SET INPUT LOWER LIMIT VAC** setting. If the AC voltage falls below this setting the INVERT (yellow) LED will flash rapidly and remain on for 3 minutes. This error is an advisory error only and will not drop the AC input.

**High AC input voltage:** Your inverter/charger monitors single cycle voltage problems from the AC source. The high AC voltage level is determined by the **SET INPUT UPPER LIMIT VAC** setting. If the AC voltage rises above this setting the INVERT (yellow) LED will flash rapidly and remain on for 3 minutes. This error is an advisory error only and will not drop the AC input.

**Generator failed to start:** Indicates that the automatic generator start system was not able to successfully start the generator. The system completes five start cycles and requires that the generator operate for a minimum of 5 minutes before the starting attempts counter is cleared. To manually clear this error, press the green GEN MENU button on the SWRC to access the **SET GENERATOR** menu item, then select **OFF** and then **AUTO** or **ON**.

**Generator stopped due to V/F:** Indicates that the automatic generator start system was not able to successfully connect to the generator after it was running. If the generator runs for 10 minutes without operating in the AC voltage and frequency tolerance windows, then the automatic start system stops the generator and indicates an error condition. To manually clear this error, press the green GEN MENU button on the SWRC to access the **SET GENERATOR** menu item, then select **OFF** and then **AUTO** or **ON**.

**Gen Max Run Time:** An **ERROR** LED will turn on if the generator run time has exceeded the **SET MAXIMUM RUN TIME** setting. This setting is intended to indicate excessive generator operation because the system has not been able to fully charge the battery. Operating heavy loads while charging, an unstable generator or even low electrolyte levels in the battery can cause this. If the default value results in repeated error conditions, then increasing the setting may be necessary for your application. This may occur with systems that have very large batteries that require long charge periods or systems with small generators that have limited battery-charging ability. This **ERROR** is an advisory indication only and will not stop the generator. You can reset this **ERROR** LED by selecting **OFF** and then **ON** from the **SET GENERATOR** menu item, accessed by pressing the green **GEN MENU** button on the SWRC.

**Gen speed error:** Indicates that the automatic generator start system has detected that the generator frequency is not well adjusted. This error condition will cause the red **ERROR** LED to illuminate, but will not cause the automatic generator start system to shut down. If the inverter can not synchronize to the generator after a 10-minute period, then the **GEN SPEED ERROR** condition will be reached.

## ORANGE = CHARGE

**ON:** This orange LED will be lighted when the unit is charging. The inverter is charging at a constant current, causing battery voltage to rise near the **BULK VOLTS DC** setting (*default = 14.4 VDC*). Once at this level, the current will taper off until the battery charger has maintained the batteries near the **BULK VOLTS DC** setting for the time period of the **ABSORPTION TIME** setting, at which time it then regulates the charging process at the **FLOAT VOLTS DC** setting.

## AC SIDE

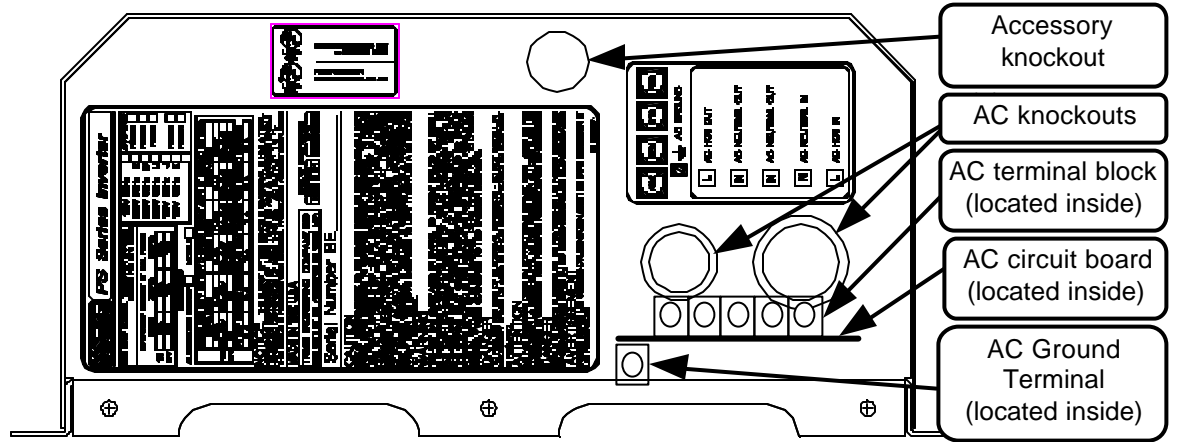

Figure 5, PS Series AC Side

## AC CIRCUIT BOARD

By removing the Access Panel, you will be able to gain access to the AC circuit board, which includes the AC terminal block and four RJ11 jacks for connecting specific optional components.

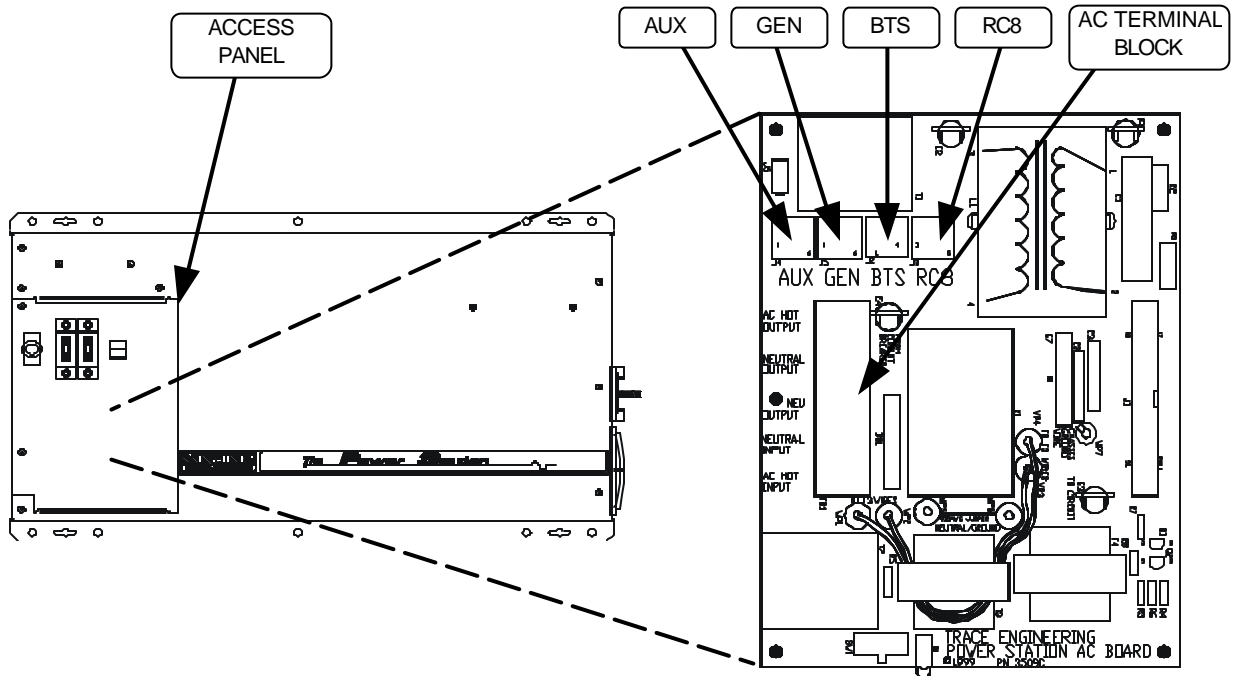

Figure 6, AC Circuit Board

**AUX** - RJ11 connection jack for the optional plug-in *Auxiliary Relay Module*. The Auxiliary Relay Module consists of two voltage-controlled relays and is used to simplify installations that have battery voltage related tasks to perform. The relays are single pole double throw, five amp relays. Both the normally closed and normally open contacts are available for each relay. The operation of each relay is individually controlled and adjustable with a SWRC via the user menu. The auxiliary relays on the **AUXILIARY RELAY MODULE** operate independently of the inverter or charger.

# CONTROLS, INDICATORS AND COMPONENTS

**GEN** - RJ11 connection jack for the optional plug-in *Generator Relay Module*. The Generator Relay Module consists of signal relays and allows connection and automatic control of “two-wire” type generators. The relays are single pole double throw, five amp relays. Both the normally closed and normally open contacts are available for each relay. The operation of each relay is controlled and adjustable with a SWRC via the user menu.

**RC8** - RJ11 connection jack for the optional plug-in *RC8 remote*. Allows remote On/Off control of the inverter at a distance of up to 50 (RC8/50) or 100 (RC8/100) feet away, functionally identical to the On/Off Power Switch on the inverter.

**BTS** - RJ11 connection jack for the plug-in external *Battery Temperature Sensor (BTS)*. The BTS automatically fine-tunes the charging process of the battery charger in relation to temperature. If the temperature sensor is NOT installed and if the battery is subjected to large temperature variations, a shorter battery life cycle may be expected.

## AC TERMINAL BLOCK

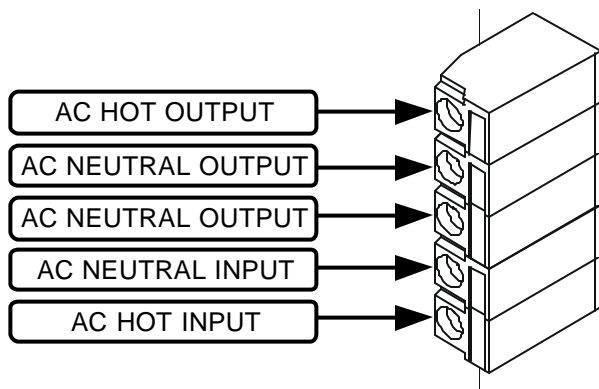

Figure 7, AC Terminal Block

A five pole terminal block is provided for hardwiring the inverter's AC output the AC input connections. It is located on the left-hand side of the inverter, enclosed under the access panel. The terminal block will accept wire up to #6 AWG.

Depending on your unit's configuration (See the **UNIT IDENTIFICATION** section on page 7 to determine your unit's particular configuration) the AC input and output neutrals are configured differently.

This manual is specific to models designed for use in Alternative Energy or Back-Up Power systems in permanent structures, such as homes and commercial buildings. All of the PS Series units marked with the Alternative Energy configuration are designed with the three NEUTRAL terminals being common to each other and can be used in any combination or order. It is often simpler to only connect one AC neutral wire to the inverter and make the other neutral connections at a central point such as at an AC load center, etc. The additional AC NEUTRAL OUTPUT is provided for use when installing the optional *Branch Breaker Kit*.

## AC GROUND TERMINAL

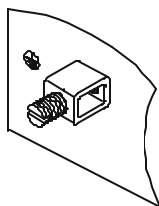

The AC Safety Ground Terminal - assessable through the AC access cover - is used to connect the exposed chassis of the inverter to the AC grounding system. This terminal accepts wires from #14 AWG to #2 AWG.

Figure 8, AC Ground Terminal



## DC SIDE

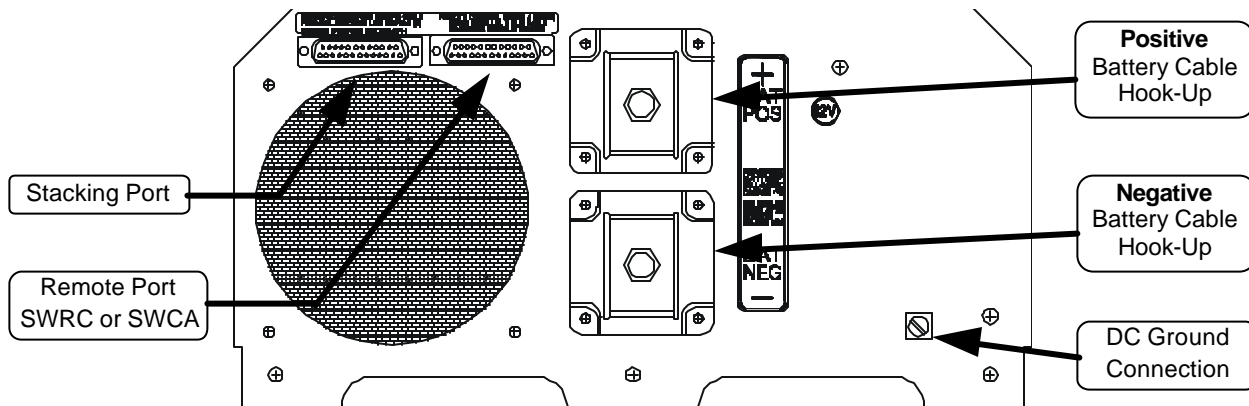

Figure 9, PS Series DC Side

### STACKING PORT

The stacking port allows two PS Series Inverter/Chargers (AE configuration models only) to be used in the same system. The inverters can be used in a “**SERIES**” configuration to operate 240 VAC loads and to connect to 120/240 VAC power systems. A series stacking interface cable (**SWI**) is required to connect the series stacking ports of the inverters. This port is also used to connect two units in a “**PARALLEL**” configuration. The parallel stacking interface cable (**SWIPAR**) allows two inverters to be connected to provide twice the continuous and surge capability at the same AC voltage. See the **USING MULTIPLE INVERTERS** section on page 92 for more information.

### REMOTE PORT

The PS Series can be controlled remotely from the unit by plugging in a SWRC remote control or SWCA communications adapter. See the **OPTIONS** section starting on page 127 for a complete description of the SWRC and SWCA.

### BATTERY POSITIVE & NEGATIVE TERMINALS

These terminals are where you connect your battery cables. **WARNING: Ensure your battery/cable polarity is correct, this inverter is not reverse polarity protected.** If the positive terminal of the battery is connected to the negative terminal of the inverter and vice versa, the result will be instantaneous failure of nearly every power transistors. Color-code the cables with colored tape or heat shrink tubing [the standard is red for positive (+) and black for negative (-)] and double-check the polarity with a voltmeter before making the battery connections.

### DC EQUIPMENT/CHASSIS GROUND TERMINAL

This connection is used to connect the exposed chassis of the inverter to the DC grounding system. The terminal accepts wires from #14 AWG to #2 AWG.

**PAGE  
INTENTIONALLY  
NOT USED**

## INSTALLATION

This section is **very important**, since it tells you how to properly install your PS Series Inverter/Charger. It becomes very frustrating when your inverter system does not perform properly, simply because care was not taken during installation. Please read this entire section carefully. You will save time and avoid common mistakes.

This section also describes the requirements and recommendations for installing the PS Series Inverter/Charger. In the U.S., the National Electrical Code (NEC) defines the standards for both the AC and DC wiring in residential and commercial applications. It will list the requirement for wire sizes, overcurrent protection and installation methods and requirements. There are still many other variables not covered by the NEC. Most are determined by the level of automatic operation, the amount of external AC and DC power to be controlled and the loads to be operated.

The NEC standards and regulations are described here in general for your convenience, and are not represented as comprehensive or complete. For comprehensive and complete official standards and regulations, write the addresses listed below:

NFPA - National Fire Protection Association  
*National Electrical Code Handbook*  
1 Batterymarch Park,  
PO Box 9101  
Quincy, MA 02269-9101  
617-770-3000.

Before beginning the installation of the PS Series Inverter/Charger, read all instructions. Disconnect all sources of AC and DC power to prevent accidental shock. Disable and secure all AC and DC disconnect devices and automatic generator starting devices.

**All installations should meet local codes and standards and be performed by qualified personnel such as a licensed electrician.** Although the DC electrical system may be "low voltage", significant hazards may be present, particularly from short circuits of the battery system. Inverter systems by their nature involve power from multiple sources (inverter, generator, utility, batteries, solar arrays etc.) that add hazards and complexity that can be very challenging.

After you have finished installing your unit, continue with the **FUNCTIONAL TEST** section on page 27. This functional test should be completed prior to configuring your unit's Menu System for your specific operation.

## LOCATION

Inverters are sophisticated electronic devices and should be treated accordingly. Treat the inverter as you would any fine piece of electronic equipment. When selecting the location to install the inverter, don't think of it in the same terms as the other interfacing equipment, e.g. batteries, diesel generators, motor generators, washing machines etc. This is a highly complex microprocessor controlled device. There are nearly 500,000 silicon junctions in its output devices and integrated circuits. The crystal oscillator runs at 4 megahertz. The drive circuitry timing is accurate to a thousandth of a second. Genetically speaking, it is a cousin to stereo equipment, television sets or computers. The use of conformal-coated circuit boards, plated copper bus bars, powder coated metal components, and stainless steel fasteners improves tolerance to hostile environments. However, in a corrosive or condensing environment (one in which humidity and/or temperature change cause water to form on components) all the ingredients for electrolysis are present - water, electricity and metals. **In a corrosive or condensing environment, the life expectancy of the inverter is indeterminate and the warranty is voided if corrosion is the cause of failure.**

Caution: It is in your best interests to install the inverter in a dry, protected location away from sources of fluctuating or extreme temperatures and moisture. Exposure to saltwater is particularly destructive and potentially hazardous.

Locate the inverter as close to the batteries as possible in order to keep the battery cable length short. However, **do not** locate the inverter above the batteries or in the same compartment as vented batteries. Batteries generate hydrogen sulfide gas, which is very corrosive to electronic equipment and everything else. They also generate hydrogen and oxygen. If accumulated, an arc caused by the connecting of battery cables or the switching of a relay could ignite this mixture. Mounting the inverter in a ventilated enclosure with sealed batteries is acceptable.

# INSTALLATION

This inverter can create RFI (Radio Frequency Interference). Keep this in mind when determining the placement of the inverter. You should locate the inverter as far away as possible from any electronic devices that may be susceptible to RFI.

## MOUNTING

UL Standard 1741 requires that the inverter be mounted on a vertical surface (on a wall) and that the keyhole slots not be used as the only method of mounting. The purpose of the wall mounting requirement is to orient the inverter so that its bottom cover, which has no holes, will not allow burning material to be ejected in case of an internal fire. Use 1/4" minimum diameter bolts for mounting. The mounting must be capable of supporting twice the weight of the inverter in order to comply with UL 1741.

## VENTILATION

Installation of the inverter in a properly ventilated area/enclosure is necessary for efficient operation of the unit. The inverter's thermal shutdown point will be reached sooner than normal in a poorly ventilated environment and will result in a lower peak power output, reduced surge capability, and potentially shorter inverter life. **Note:** Do not operate the inverter in a closed-in area or restrict ventilation in any way.

Testing has shown that the volume of the area/enclosure is not as important as the overall ventilation. A minimum airspace clearance of 1-1/2 inches around the top and 3 inches of clearance at the right side of the inverter will provide adequate ventilation. Because the bottom of the PS Series chassis is not vented, clearance between the enclosure and the bottom of the inverter is not critical. A fresh air intake port should be provided directly to the right side and an exhaust port on the top side will allow cool outside air to flow through the inverter and back out of the enclosure.

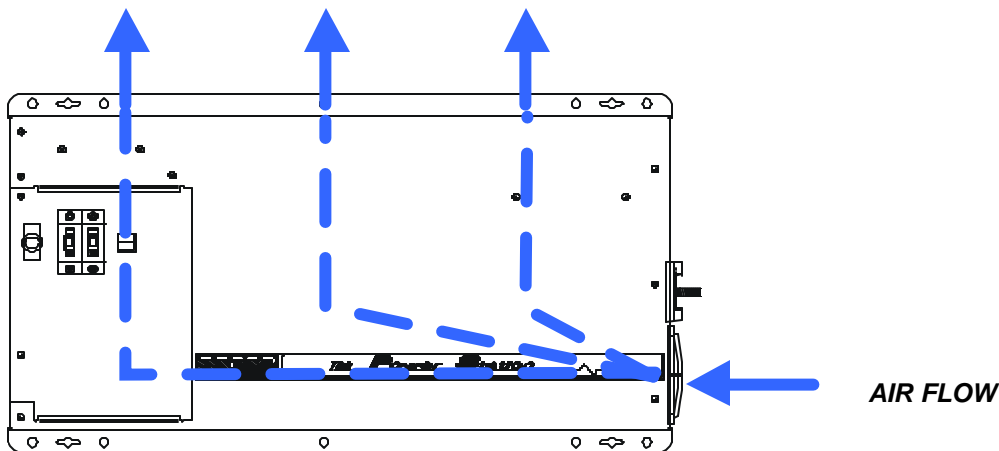

Figure 10, Airflow Intake Location

## AC WIRING

This section describes AC wiring requirements and recommendations; including AC connections; wire sizing; overcurrent devices; GFCI's; external relays; hookup procedure; and neutral-to-ground switching. Your local electrical code and the National Electrical Code (NEC) define the standards for AC installation wiring, but there are still many installation variables to be considered. Consult the local code and the NEC for the proper wire sizes, connectors and conduit. **All installations should meet all local codes and standards and be performed by qualified personnel such as a licensed electrician.**

### AC WIRE CONNECTIONS

**IMPORTANT PRECAUTIONS - The AC OUTPUT of the inverter must at no time be connected directly to utility power or a generator. This condition can be far worse than a short circuit. If the inverter survives this condition, it will shut down until corrections are made.**

A five position terminal block is provided to make the AC connections. The terminal block is located on the left-hand side of the inverter, enclosed under an access panel (see page 9 for exact location). The terminal block is used to hardwire all AC connections.

Before making any AC connections, make sure that the inverter is disconnected from the battery (or battery bank). Feed the wires through conduit fittings located on the left side or left bottom side of the inverter. (Note: Conduit fittings must be purchased separately and are required by code to comply with residential and commercial installations).

The NEC requires that disconnect switches be provided in the AC input and output wiring circuits. AC circuit breakers in an AC load center can be used to meet this requirement. The wiring both in and out of the inverter must also be protected from short circuits and overloads by a fuse or circuit breaker. Consult the NEC or your local code for more information and for other wire sizes. Table 1 on page 19 gives suggestions for wire sizing.

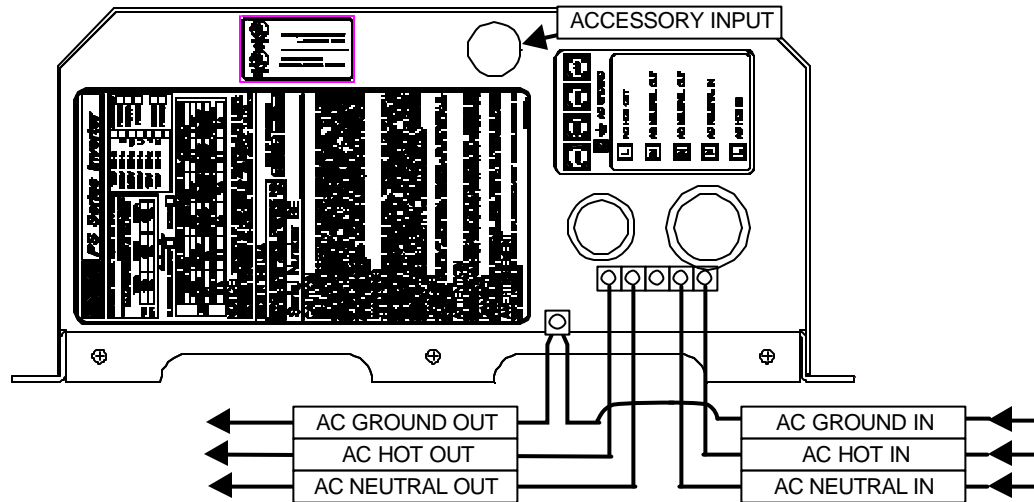

Figure 11, AC Wire Connections

The three neutral terminals are common to each other and can be used in any combination or order. It is often easier to only connect one AC neutral wire to the inverter and make the other neutral connections at a central point such as in the AC load center, etc. The extra output neutral is used if installing the optional *Branch Breaker Kit*. Consult your local code for more information and acceptable wire sizes and configurations.

Use Table 1, below, to determine the proper size wire you require for your installation. These recommendations may not meet all local code or the NEC requirements, consult your applicable electrical code for more information regarding acceptable fuse and cable sizes.

Table 1, Recommended Minimum AC Wire Sizes To Breaker/Fuse Size at 75° C

INVERTER MODEL	FULL PASS-THRU CAPABILITY	MAXIMUM FUSE/BREAKER REQUIRED	CABLE SIZE REQUIRED IN CONDUIT	CABLE SIZE REQUIRED IN "FREE AIR"*
PS2512/PS2524	50 amps	60 amps	# 6 AWG (THHN)	# 8 AWG (THHN)
PS2212E/PS2524E	30 amps	30 amps	# 10 AWG (THHN)	# 12 AWG (THHN)

\* The term "free air" is defined by the NEC as cabling that is not enclosed in conduit or a raceway. Cables enclosed in raceways or conduits have substantially lower continuous current carrying ability due to heating factors.

# INSTALLATION

---

## AC INSTALLATION GUIDELINES

The following steps are a basic guideline for connection of the AC wiring into and out of the inverter.

1. Disconnect the inverter from the battery bank (if already connected), by either removing the DC side fuse, or opening the DC disconnect. Then remove the AC wiring compartment cover from the front of the inverter by removing the two screws on the cover.
2. If conduit will be utilized (consult code, it may be required in your installation), determine which knockout(s) will be utilized and remove them from the inverter. The knockout sizes are shown in *Figure 38, PS Series – Showing Knockout Sizes for AC Wiring* on page 119. Using appropriate conduit connectors, fasten the conduit to the inverter. Feed all AC wiring through the conduit and into the inverter AC terminal block. Be sure to leave yourself several extra inches of wire to work with. Remember that you need at least two sets of three conductor wiring, one for AC Hot, neutral, and ground into the inverter, and another for AC hot, neutral and ground out of the inverter to the loads. Torque all AC terminals to 10 to 15 inch-pounds.
3. Connect the hot (black) and neutral (white) wires from the AC source to the **AC HOT IN** and **AC NEUTRAL IN** terminals in the AC terminal block. The safety ground (green) should be connected to the terminal stud labeled “AC Ground” bolted to the chassis. Repeat the procedure for the AC wiring going to the AC sub-panel which will power the loads, except connect these wires to terminals labeled the **AC HOT OUT** and **AC NEUTRAL OUT**.
4. Inspect all wiring for proper installation and then replace and secure the access cover.

### IMPORTANT PRECAUTION

**The AC output of the inverter must at no time be connected directly to utility power or a generator.** This condition can be far worse than a short circuit. If the inverter survives this condition, it will shut down until corrections are made. Connection to a utility or generator must be only done internally by the inverters built-in relays. This allows the inverter to first synchronize to the other AC sources waveform, preventing damage. Connect the utility or generator only to the provided **AC HOT IN** and **AC NEUTRAL IN** terminals. When the inverter output is connected directly to an external source, the inverter will shut down and indicate an error. With the SWRC connected, the **ERROR CAUSES** menu heading will show a **YES** for the **AC SOURCE WIRED TO OUTPUT** menu item. Either determine the source of the AC or call a qualified electrician to correct the situation.

### EXTERNAL AC TRANSFER RELAYS

**It is not acceptable to switch the AC input from one AC source to another while the inverter is connected.** While the inverter is connected, switching the AC input from one source to another can result in a loss of synchronization that can cause a severe overcurrent condition that is far worse than short circuiting the inverter. **If a transfer relay is used, it must provide a center “OFF” (“break before make”) position that causes a loss of input power to the inverter for a period of at least 100 milliseconds.**

This will allow the inverter to disconnect from the original AC input and then re-synchronize to the new AC source through the AC input terminal. During the transition period, the inverter will have to operate the load while it re-synchronizes to the new AC source (about a thirty-second period at the minimum). Most transfer relays will switch too fast for the inverter to detect - and will cause the inverter to lose synchronization with the AC source. This is indicated by the inverter shutting down upon transfer and the red **ERROR** LED indicator turning on.

Manually, hand operated transfer switches may be acceptable since the transfer time can be slow enough for the inverter to detect. The switch must go through a center “OFF” position. They are often used to switch from one generator to another.

### 120 VAC GROUND FAULT INTERRUPT OUTLETS (GFI'S)

The following 120 VAC GFI's have been tested and found to work satisfactorily with our inverters:

LEVITON	6599
PASS & SEYMOR	1591 4A957
ACE Hardware	ACE 33238

## WARNING LABEL

A warning label is provided to inform all personnel that an inverter is installed in your electrical system. This label should be installed at the electrical panel that is being powered by the inverter. Be cautious until the inverter is disconnected from your electrical system.



Figure 12, Warning Label

## DC WIRING

This section describes DC cabling requirements and recommendations including cable sizing, DC conductor ampacity ratings, overcurrent devices, terminals and lugs, and inverter terminal connections.

**WARNING! Battery cables that are very small will melt and burn the first time the inverter is operated at high power levels. The inverter's maximum peak current requirements are high. If battery cables are too small and/or connections are loose, efficiency and maximum output power are degraded. Small cables or loose connections may cause dangerous overheating and a fire.**

## BATTERY CABLE SIZING

The larger the battery cables the better. Undersized cables result in additional stress on the inverter, lower efficiency, reduced surge power and lower peak output voltage. Don't use cables that are too small and degrade the efficiency that we have worked so hard to achieve and you have paid so much to own.

Also, don't use cables that are too long - the shorter the better. The lower the DC system voltage, the shorter the cables need to be. If long cables are required, either oversize them substantially, or switch to a higher voltage system, such as 24 vdc or 48 vdc. On 12-vdc system, cables may need to be doubled up (paralleled) to get maximum performance from the inverter.

NOTE: Do not separate the positive and negative cables - taping them together in parallel is best. This reduces the inductance of the wire resulting in a better waveform and reduces the current in the inverter's filter capacitors. Make the battery cables as short as possible.

Although large cables may seem expensive, spending an additional \$100 or more to ensure the performance of your inverter is a wise investment. Using cables that are too small is like putting cheap tires on a high performance sports car - the results will be disappointing.

If the system is expected to operate at the inverter's continuous power level rating for long periods of time (over an hour), larger disconnects and cables may be required. Most systems do not operate at full capacity for periods exceeding an hour and can operate satisfactorily with the following cable and disconnects shown. If your system includes enormous batteries or has a very large DC source able to continuously power the inverter (such as a hydroelectric plant, etc.) then increasing the disconnect and cable sizes may be required to prevent nuisance tripping of a breaker or blowing of fuses.

The following table gives recommended minimum cable sizes for various cable lengths and inverter voltages. These recommendations may not meet all local or NEC code requirements. **Use only copper cables**

Table 2, Minimum Recommended Battery Cable Size Vs. Cable Length

INVERTER MODEL	TYPICAL DC AMPS	1 TO 3 FEET ONE WAY	3 TO 5 FT ONE WAY	5 TO 10 FT ONE WAY
PS2512	267 amps	#4/0 AWG / 67.4 mm <sup>2</sup>	#4/0 AWG / 107 mm <sup>2</sup>	Not Recommended
PS2524/PS2524E	134 amps	#2/0 AWG / 67.4 mm <sup>2</sup>	#2/0 AWG / 67.4 mm <sup>2</sup>	#4/0 AWG / 107 mm <sup>2</sup>
PS2212E	235 amps	#2/0 AWG / 67.4 mm <sup>2</sup>	#4/0 AWG / 107 mm <sup>2</sup>	#4/0 AWG / 107 mm <sup>2</sup>

# INSTALLATION

## DC DISCONNECT AND OVERCURRENT PROTECTION

For safety and to comply with regulations, battery over-current protection is required. Fuses and disconnects must be sized to protect the wiring in the system. The fuse or disconnect is required to open before the wire reaches its maximum current carrying capability.

For residential and commercial electrical systems, the National Electrical Code requires both overcurrent protection and a disconnect switch. These installation parts are not supplied as part of the inverter. However, Trace Engineering offers a DC rated, UL listed, circuit breaker disconnect specifically designed for use with Trace inverters for applications requiring NEC compliance. Two amperage ratings are available - a **DC250** (250 amps) and a **DC175** (175 amps). These disconnects are available in a single or double pole configuration to handle either one or two inverters. The DC disconnect enclosure will accommodate up to four smaller breakers for use as DC load disconnects, PV array disconnects, etc. and the top is designed to allow direct connection of up to two Trace Engineering charge controllers. The Trace DC disconnect is not designed to accept doubled (paralleled) cables which may be required for long cable runs. Also, the plastic red and black covers on the end of the inverter are not designed to accommodate dual cables. If dual cables are used, the optional conduit box (**PSCB**) should be used.

When sizing the DC disconnect, the expected continuous load on the inverter is used to determine the DC current involved. You must account for the efficiency loss through the inverter, which increases the DC current draw. Divide the maximum continuous current draw by the lowest efficiency to determine the DC current, a 25% safety margin should be included to comply with the code requirements. When a breaker has been selected as the overcurrent device, tighter sizing may be acceptable since the breaker is more easily reset when compared to a high current, bolt-in type fuse.

Some installations may not require conduit or a means of disconnection, although overcurrent protection (fuse) is still required. Trace Engineering offers a fuseblock (**TFB**) that provides the code required inverter overcurrent protection for these applications.

TFB's include a fast acting, current limiting class-T fuse to protect your battery, inverter and high amperage cables from damage by short circuits and overloads. This fuse provides extremely fast protection when a short circuit occurs. When properly selected, it also has a time delay that allows the inverter to surge to full power without blowing the fuse. A slide off cover prevents accidental contact with the fuse's live terminals. For maximum protection, install the fuseblock within 18 inches (45 cm) of the battery. The fuses are available in 110, 200, 300, and 400 amp sizes.

Use Table 3 below, to determine the proper size disconnect (breaker) or fuse for the battery cables you are using. These recommendations may not meet all local code or the NEC requirements, consult your applicable electrical code for more information regarding acceptable fuse and cable sizes.

Table 3, Battery Cable to Maximum Breaker/Fuse Size

CABLE SIZE REQUIRED	RATING IN CONDUIT	MAXIMUM BREAKER SIZE	RATING IN "FREE AIR"	MAXIMUM FUSE SIZE
00 AWG	175 amps	175 amps	265 amps	300 amps*
0000 AWG	250 amps	250 amps**	360 amps	400 amps*

\* The NEC allows rounding up to the next standard fuse size from the cable rating, i.e. 150-amp cable size rounds up to a standard 175-amp size. The term "free air" is defined by the NEC as cabling that is not enclosed in conduit or a raceway. Cables enclosed in raceways or conduits have substantially lower continuous current carrying ability due to heating factors.

\*\* Nuisance tripping is possible if operated at 2.5 kVA continuously with a 250-amp breaker

Contact your Trace dealer to order the inverter disconnects/fuses or see the **OTHER PRODUCTS** section on page 129 for more information.



## BATTERY CABLE CONNECTIONS

Cables must have crimped (or preferably, soldered and crimped) copper compression lugs unless aluminum mechanical lugs are used. Soldered connections alone are not acceptable. We suggest using high quality, UL-listed Trace Engineering battery cables. These cables are available in a specific assortment of sizes from 1-½ to 10 feet, and in 2/0 or 4/0 AWG. They are color-coded and have pressure crimped, sealed ring terminals. Contact your Trace Engineering dealer to order. Figure 13, illustrates the proper method to connect the battery cables to the PS Series Inverter/Charger.

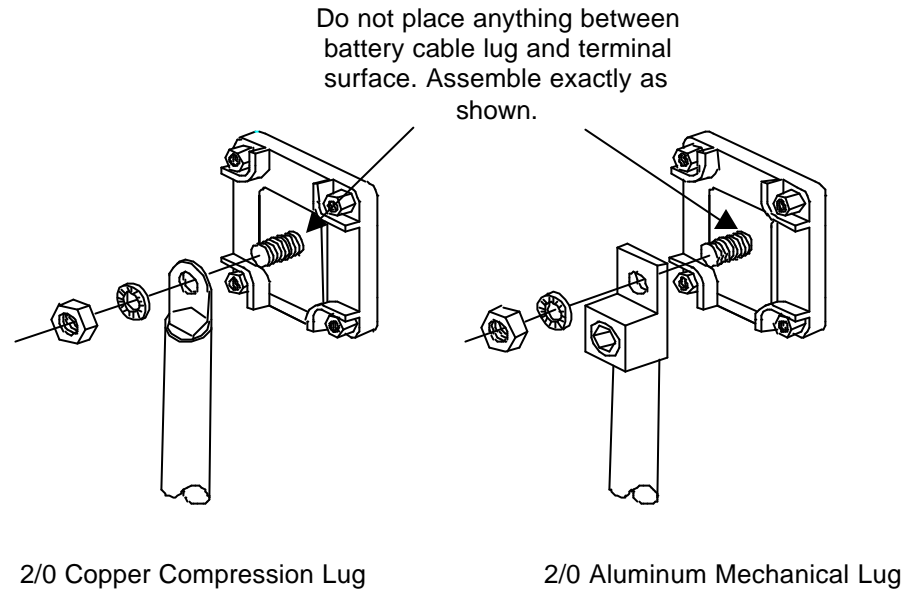

Figure 13, Battery to Inverter Cable Connection

### INSTALLATION GUIDELINES - BATTERY CABLES

**Warning! This inverter is not reverse polarity protected.** If the positive terminal of the battery is connected to the negative terminal of the inverter and vice versa, the result will be instantaneous failure of nearly every power transistor. This type of damage is obvious and requires an extensive rebuilding of the inverter at your own cost. It is not covered by the warranty.

**Ensure that the inverter is off before connecting or disconnecting the battery cables and that all AC power is disconnected from the inverter's inputs.**

Determine the correct size battery cable to use for your installation from *Table 2, Minimum Recommended Battery Cable Size Vs. Cable Length* on page 21 and the proper size disconnect/fuse from *Table 3, Battery Cable to Maximum Breaker/Fuse* on page 22. Color-code the cables with colored tape or heat shrink tubing [the standard colors are red for positive (+) and black for negative (-)]. Always double-check the polarity with a voltmeter before making the battery connections

Install the over-current device (fuse or circuit breaker) between the inverter and battery - as close as possible to the battery - in the ungrounded conductor [typically the positive (red) cable]. Connect a cable from the battery negative terminal to the negative (black) terminal on the inverter.

**Observe Battery Polarity!** Place the battery cable ring terminals over the stud and directly against the inverter's battery terminals. **Red** is positive (+), **Black** is negative (-). Use a 1/2-inch wrench or socket to tighten the 5/16 SAE nut to 10-15 foot/pounds. **Do not place anything between the cable ring terminal and the flat metal part of the terminal or overheating of the terminal may occur. DO NOT APPLY ANY TYPE OF ANTI-OXIDANT PASTE until after the battery cable wiring is tightened to 10-15 foot-pounds!**

**Note:** Connecting the battery cables to the inverter battery terminals may cause a brief spark or arc - usually accompanied by a "snapping" sound. This is normal - don't let it scare you. It is simply the internal capacitors of the inverter being charged.

# INSTALLATION

---

## SYSTEM GROUNDING

Even system designers and electricians often misunderstand system grounding. The subject is more easily discussed if it is divided into three separate subjects. The grounding requirements vary by country and application. Consult local codes and the NEC for specific requirements. Refer to *Table 18, Safety Ground Wire Size Table* on page 132 for safety ground wire sizes.

## EQUIPMENT OR CHASSIS GROUNDS

This is the simplest part of grounding. The idea is to connect the metallic chassis of the various enclosures together to have them at the same voltage potential, which reduces the possibility for electric shock. It also provides a path for fault currents to flow through to blow fuses or trip circuit breakers. The size of the connecting conductors should be coordinated with the size of the overcurrent devices involved. Under some circumstances, the conduit and enclosures themselves will provide the current paths.

## GROUNDING ELECTRODES/GROUND RODS

The purpose of the grounding electrode (often called a ground rod) is to “bleed” off any electrical charge that may accumulate in the electrical system and to provide a path for “induced electromagnetic energy” or lightning to be dissipated. The size for the conductor to the grounding electrode or grounding system is usually based on the size of the largest conductor in the system. Most systems use a 5/8” (16 mm) copper plated rod 6 feet (2 meters) long driven into the earth as grounding electrode. It is also common to use copper wire placed in the concrete foundation of the building as a grounding system. Either method may be acceptable, but the local code will prevail. Connection to the ground electrode should be done with special clamps located above ground where they can be periodically inspected.

It is often desirable to use multiple ground rods in larger system. The most common example is providing a direct path from the solar array to earth near the location of the solar array. Most electrical codes want to see the multiple ground rods connected by a separate wire with its own set of clamps. If this is done, it is a good idea to make the connection with a bare wire located outside of the conduit (if used) in a trench, the run of buried wire may be a better grounding electrode than the ground rods!

Well casings and water pipes can also be used as grounding electrodes. Under no circumstance should a gas pipe or line be used. Consult local codes and the NEC for more information.

## BONDING THE GROUNDING SYSTEM

This is the most confusing part of grounding. The idea is to connect one of the current carrying conductors (usually the AC neutral and DC negative) to the grounding system. This connection is why we call one of the wires “neutral” in the North American type electrical systems. You can touch this wire and the grounding system and not be shocked. When the other ungrounded conductor (the hot or positive) touches the grounding system, current will flow through it to the point of connection to the grounded conductor and back to the source. This will cause the overcurrent protection to stop the flow of current, protecting the system. This point of connection between the *grounding system* (ground rod, vehicle frame, boat hull, etc.), the current carrying *grounded conductor* (AC neutral and DC negative), and the *equipment grounding conductor* (green ground wire, equipment ground) is often called a “bond”. It is usually located in the overcurrent protection device enclosure. Although it can be done at the inverter, codes do not generally allow it since the inverter is considered a “serviceable” item that may be removed from the system. In residential systems, it is located at the service entrance panel, after the power has gone through the kilowatt-hour meter of the utility. In mobile applications (RV and marine), this “bond” is provided by the different AC sources on board.

Bonding must be done at only one point in an electrical system. Our systems inherently have two separate electric systems - a DC system and an AC system. This means that two bonding points will occur in all inverter applications. The bonding point will also be connected to the equipment (chassis) grounding conductors. It is common to have two separate conductors connect the ground electrode and the two bonding points. Each conductor should use a separate clamp.

In some countries, the neutral is not bonded to the grounding system. This means you may not know when a fault has occurred since the overcurrent device will not trip unless a “double” fault occurs. In some marine electrical codes, this type of system is also used.

## GROUNDING VS. LIGHTNING

This information is intended to provide basic grounding techniques that will help prevent inverter damage due to lightning. It is not intended to be a complete course on grounding or a guarantee against protection during a lightning strike situation. The NEC is the ultimate authority as to legitimate grounding techniques for your electrical system.

**If an electrical system has components grounded at different points in the earth, large voltage differences will exist between these points during a lightning strike (Figure 14, Multiple Point Ground System). If this voltage appears between the AC and DC side of the inverter, it will fail. All Trace inverters are designed to withstand a minimum of 1750 volts between AC and ground, and 500 volts between DC and ground.**

### ONE GROUND FOR ALL EQUIPMENT

The first step in inverter protection is to make sure that all equipment in the system is physically grounded at the same location. This assures that there is no voltage potential between grounds in the system (Figure 15, Single Point Ground System). No voltage means no current flow through the system. Practically speaking, this would mean connecting the generator and battery grounds together, as well as the case or "safety" grounds in the system, and then attaching all to the same earth grounding rod (See the NEC for specific information on grounding requirements, and hardware).

In severe conditions, the generator frame should physically be isolated from the earth by a wood frame or some other insulating means. This assures that the single point ground system is maintained.

### KEEP EQUIPMENT CLOSE TOGETHER

All equipment involved in a system should physically be located as close as possible to one another. This reduces the potential that is developed between the ground site and the individual components of the system during a lightning strike. This single point grounding greatly reduces the potential for lightning damage to electrical equipment.

If you are unable to achieve single-point grounding due to large distances between equipment or other variables, other means of lightning protection must be considered. Consult a reputable lightning protection company.

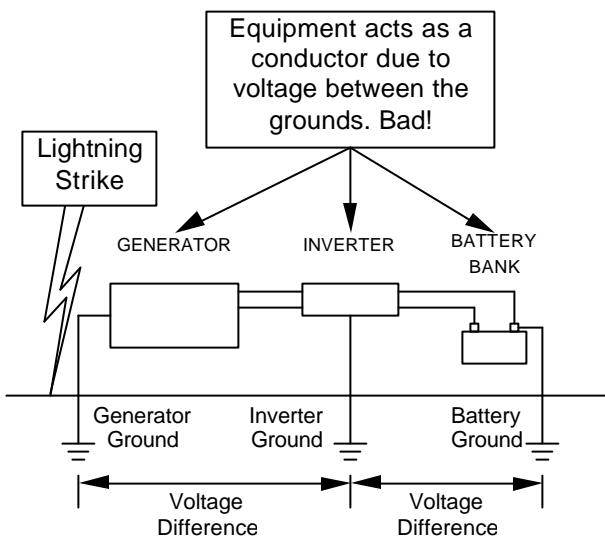

Figure 14, Multiple Point Ground System

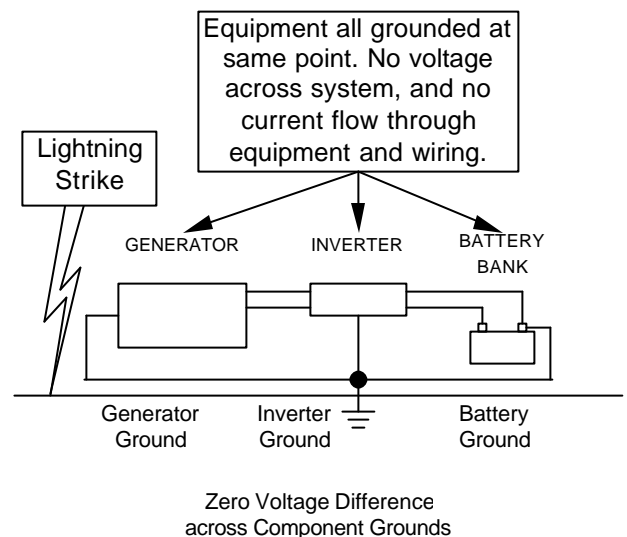

Figure 15, Single Point Ground System

# INSTALLATION

---

## QUICK INSTALL

This section is provided for installers, licensed electrical contractors, and knowledgeable laymen as a quick reminder on the essential steps to quickly install the Trace PS Series Inverter/Charger. If you haven't had experience with the PS Series Inverters/Charger, you are urged to read the entire **INSTALLATION** section before installing the inverter/charger.

## MOUNTING

Mount the unit securely in a clean, dry, properly ventilated enclosure. Do not mount the unit in the same enclosure as vented or maintenance-free type vented batteries. Bolt the unit securely. Allow adequate clearance to allow access to the indicators or controls.

## DC CABLING

1. Connect a cable from the positive terminal of the battery (or battery bank) to the battery positive (red) terminal of the inverter. See Table 16 in the Appendix to determine the proper size cable and length of run needed to use with your inverter model and for your specific application. The National Electric Code (NEC) requires the use of a DC fuse or disconnects with this cable. See Table 13 in the Appendix to determine the correct size fuse or breaker to use.
2. Connect an appropriate sized cable from the battery's negative terminal to the negative (black) terminal on the inverter. Torque all terminals to 10-15 foot-pounds. A 'snap' caused by charging the internal capacitors may occur. This is normal.
3. Connect a cable from the DC Ground terminal on the inverter to the system ground.

## AC IN CABLING

See Table 17, *Recommended Minimum AC Wire Sizes (75° C)* in the Appendix to determine the appropriate AC wire size.

1. Remove the knockout from the inverter chassis and install a strain relief or conduit in which to route the AC cabling in and out.
2. Connect the black wire from the hot side of the AC power to the terminal labeled **AC HOT IN** on the inverter.
3. Connect the white wire from the neutral side of the AC power source to the terminal labeled **AC NEUTRAL IN** on the inverter.
4. Connect the green wire from the ground of the AC power source to the **AC Ground Terminal** of the inverter/charger.

## AC OUT CABLING

1. Connect the black wire between the terminal marked **AC HOT OUT** to the hot bus of your AC load center or AC sub-panel.
2. Connect the white wire from the terminal marked **AC NEUTRAL OUT** to the neutral bus of your AC load center or sub-panel.
3. Connect the **AC Ground Terminal** of the inverter to the safety ground bus of the AC load center or sub-panel.

## WRAP UP

1. Secure all wiring with wire ties or other non-conductive fasteners to prevent chafing or damage. Use strain reliefs, grommets, or conduit to prevent damage to the wiring where it passes through any apertures. Tighten all connections to the correct torque (AC Connections at 20 inch-pounds; DC Connections at 10-15 foot-pounds).
2. Make a final check of all wiring, then reconnect to the AC power source.

Turn the inverter **ON** and check inverter operation (See the **FUNCTIONAL TEST** section on page 27).

## FUNCTIONAL TEST

Once the AC and DC wiring have been installed and connected, take a moment to go back over all connections and make sure they are secure and have been installed properly. Ensure that there is no AC or DC power provided to the inverter/charger and that all AC loads are disconnected from the output of the inverter.

The below steps will complete a functional test of the inverter. If any area fails, figure out why before proceeding. The **TROUBLESHOOTING GUIDE** section, starting on page 109, will hopefully help solve problems you may encounter.

1. **After ensuring the correct polarity**, apply battery (DC) power to the inverter by turning on the battery bank DC disconnect or connecting the proper fuse inline to the battery to complete the battery circuit. The inverter will power up and the **ERROR (red)** LED will be on (indicates no AC output), but the inverter will remain in the **OFF** mode. The **ERROR (red)** LED should be the only LED on at this time – if not, troubleshoot before continuing.
2. Press the **ON/OFF** switch twice (**SEARCH** then **ON**) to turn the inverter on. Monitor your **INVERTING (yellow)** LED to ensure what mode you are in:
  - **OFF** – The Inverter/Charger is off. This is the default position of the inverter upon power-up. No inverter or pass-thru power will be applied to the AC loads
  - **ONE BLINK/SEC** – The Inverter/Charger is in Search mode and is looking for an AC load greater than the **SEARCH WATTS** setting (*default = 16 watts*).
  - **DOUBLE BLINK/SEC** - The Inverter/Charger is in the Charge Only mode. The inverter will operate only as a charger (**MAXIMUM AC AMPS IN** switch must be in the **AC1** position to use the Charge Only mode).
  - **RAPID BLINK (4/sec)** - Indicates that an operating error has occurred. The inverter is protected from conditions caused by over-load, over-current, over-temperature (transformer or heatsink), high-battery, low-battery, low AC dropout or an external (stacked) error. If the inverter senses one of these situations, it will protect itself by disconnecting from the AC loads. This error condition also occurs from numerous generator-related errors, but will not disconnect the AC loads. Refer to the **TROUBLESHOOTING GUIDE** starting on page 109 to help determine your particular error cause.
  - **ON** – Indicates the Inverter/Charger is on. The inverter will produce a low audible “buzz” is able to provide power to the AC loads.

If the inverter does not produce a low audible “buzz” or come on, check all connections. Check the inverter’s DC voltage on the positive (+) and negative (–) terminals. If the DC voltage is low, the battery bank needs to be charged externally. Charge the battery bank and restart the functional test.

3. With the inverter **ON**, check the AC voltage on the AC output terminal of the inverter and ensure you get the correct AC voltage for your particular unit. After confirming the correct AC voltage, connect your AC output breaker and place a load on the inverter (plug in a light or other load to an outlet the inverter is powering), and make sure it works.
4. **Check your battery charger.** To charge your batteries, provide AC power - by plugging in a power cord or turning on the AC input breaker - to the **AC HOT IN** and **NEUTRAL IN** terminals on the inverter. The **AC IN (Green)** LED should come on, indicating that AC power is getting to the inverter. After a minimum 20 seconds delay, the **CHARGE (Orange)** LED on the inverter should be on, indicating the charger is working properly. If you have an SWRC, it should indicate which charge stage (bulk or float) the inverter is currently in. Any AC loads powered by the inverter should also work at this point since the AC input power (Utility or Generator) is passed through the inverter to power the loads.
5. **Disconnect AC power.** Take away the AC input power by turning the AC power breaker off or unplugging the AC power cord. The inverter should transfer to inverter mode immediately. The **INVERT (Yellow)** LED should come on to indicate this. The inverter will begin to produce an audible “buzz” as it takes power from the batteries and uses it to power the loads. The loads should continue to operate uninterrupted.
6. This completes the functional test, if all areas pass, the inverter is ready for use. If any of the inverter’s internal setpoints are to be adjusted, consult the **MENU SYSTEM** section starting on page 29.

**PAGE  
INTENTIONALLY  
NOT USED**

## MENU SYSTEM

### OVERVIEW

The operation of the inverter is determined by the settings in the menu system. The menu system is divided into a **USER MENU** and a **SETUP MENU**. Each of the menu systems is divided into **MENU HEADINGS** and **MENU ITEMS**. The menu headings break the menu into groups of related menu items. At the menu item level a setting can be adjusted, a mode can be selected or information can be displayed. When a number is included with the graphic of the menu heading or menu item in this manual, the value shown is the default value and is for a 12-volt domestic model (120VAC/60Hz) inverter. *For 24-volt systems, multiply the DC settings shown by 2.*

- The **USER MENU** provides the controls and settings needed on a daily basis. It allows you to turn on the inverter and generator, read the AC and DC meters, check on an error cause and even adjusts the inverter's time clock.
- The **SETUP MENU** provides all of the settings required to configure the inverter to operate in the necessary modes for your installation. They are separated from the **USER MENU** to reduce tampering and simplify the daily operation of the inverter.



The PS Series Inverter/Charger **MENU SYSTEM** can ONLY be accessed and adjusted by using a *SWRC Remote Control* or *SWCA Communications Adapter* (see **OPTIONS** on page 127 for more information on the SWCA). The SWRC enables you to configure the inverter/charger to your specific system and preferences using the menu system available in your unit. The information in the Menu System section is based on using the SWRC. However, when the SWRC is mentioned the SWCA may be used instead.

The **MENU MAP** shown on the next two pages give a visual indication of each display available when using the SWRC. It is provided to help you navigate through the different Menu Headings and Menu Items.

# MENU SYSTEM

## USER MENU MAP

<b>Menu Heading</b>	The values shown are the factory default values for 12 VDC - 120 VAC/60HZ models.
<b>Menu Item</b>	See the USER and SETUP menu item descriptions and default values for other models.
<b>Setpoint</b>	
<b>Information</b>	

Push buttons on  
**SWRC**



### MENU HEADINGS



1	2	3	4	5	6
<b>Inverter Mode</b>	<b>Generator Mode</b>	<b>Trace Engineering</b>	<b>Meters</b>	<b>Error Causes</b>	<b>Time of Day</b>
OFF SRCH ON CHG	OFF AUTO ON EQ	Press reset now for defaults	Inverter/charger amps AC 00	Low Battery voltage NO	Set Clock hour 00:00:00
CHG avail. Only in FLT mode.	Gen failed to start NO	Revision 5.0 PS AE	Input amps AC 00	Low inverter voltage NO	Set Clock minute 00:00:00
Press setpoint button to move cursor. Move cursor to Inverter OFF to ResetOverCurrent	Gen stopped due to V/F NO	5916 195th St NE Arlington, WA	Load amps AC 00	Low AC input voltage NO	Set Clock second 00
	Gen max run time error NO	98223 USA	Battery actual volts DC 12.6	High Battery voltage NO	
	Gen speed error NO	Ph 360-435-8826 Fax 360-435-2229	Battery TempComp volts DC 12.6	High AC input voltage NO	
	Load Amp Start ready NO		Inverter volts AC 00	Gen failed to start NO	<b>Generator Timer</b> 7
	Voltage Start ready NO		Grid (AC1) volts AC 00	Gen stopped due to V/F NO	Start Quiet time h:m 08:00
	Exercise Start ready NO		Generator (AC2) volts AC 00	Gen max run time error NO	End Quiet time h:m 08:00
Move cursor to GEN OFF to reset generator error.			Read Frequency Hertz 60	Gen speed error NO	Gen doesn't run during quiet time unless batt volts is less.
If no start in 5 trys then error.			Read Bulk/EQ timer h:m 00:00	Over Current NO	than LBCO volts for 30 seconds or load > load start amps.
If Gen runs for more than max run time then error.			AC1 & AC2 volts valid only when inverter synced to that input.	Transformer overtemp NO	To defeat timers set start = end.
Under/Over speed Will cause a Sync error in 10 minutes			Batt volt actual is used for LBCO, HBCO, LEX, LBCI, sell volts, and gen starting	Heatsink overtemp NO	If exercise days set to 1 then gen will always start @ endquiet
			Batt volt temp comp is used for float, bulk, eq & aux relays	AC source wired to output NO	
				External error (stacked) NO	
				High/Low ACinput voltage error	
				Detects single cycle problems with AC source during charge or Sell or passthru Reset in 3 min.	
					<b>END USER MENU</b> 8

MENU ITEMS



## SETUP MENU MAP

The **SETUP MENU** provides all the controls and settings needed when installing or adjusting the system. To access the **SETUP MENU**, press both the **red ON/OFF MENU** and **green GEN MENU** buttons on the **SWRC** at the same time. To exit the **SETUP MENU**, press the **red ON/OFF MENU** button or press the down **MENU HEADING** button until you reach the **USER MENU** (menu headings 1 – 8).

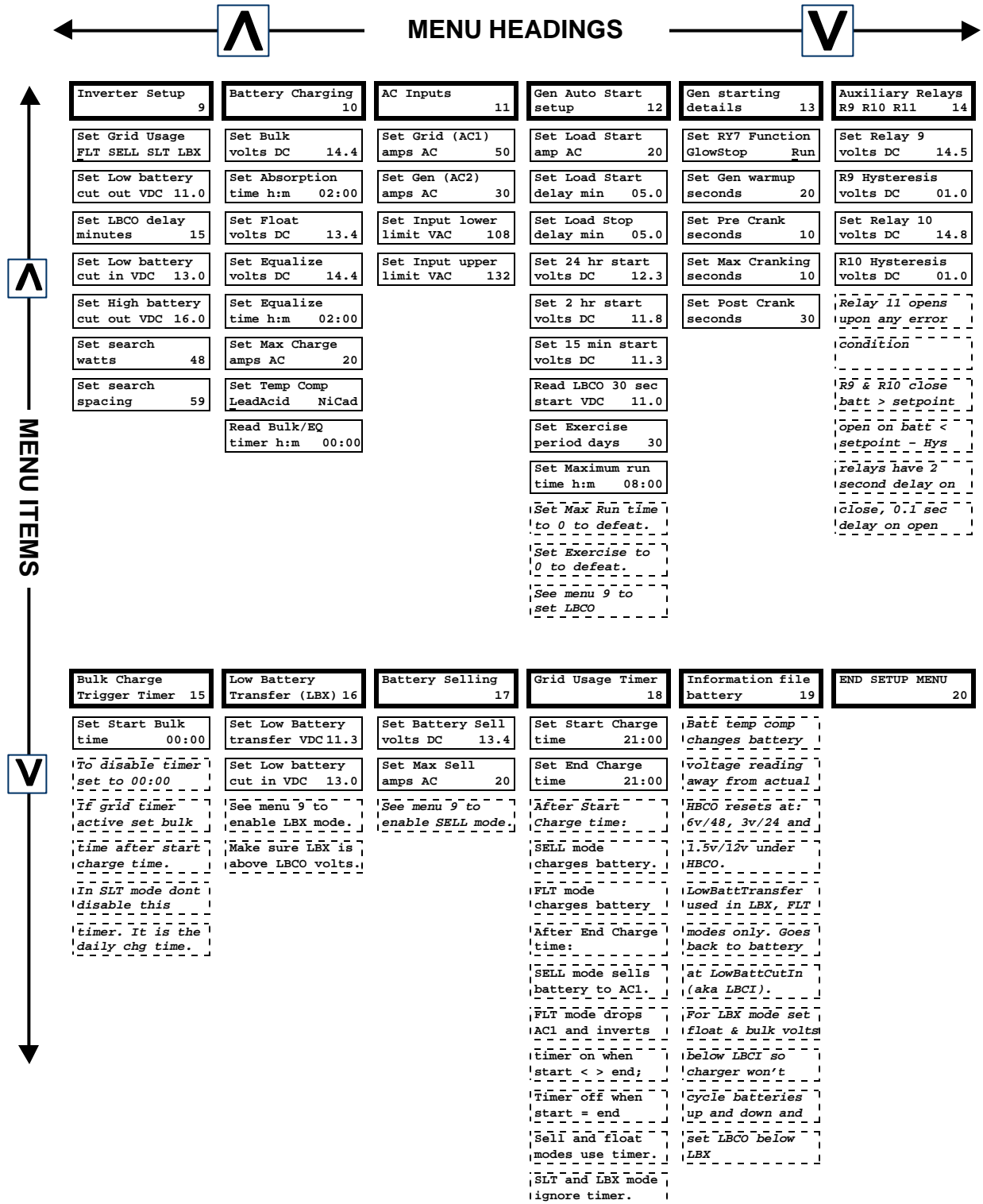

Note: The values shown are the values for a 12 VDC – 120VAC/60HZ model. Multiply the DC settings by 2 for 24 VDC models. See the **USER** and **SETUP** menu item descriptions and default values for other models.

# MENU SYSTEM

## SWRC REMOTE CONTROL

The optional SWRC remote control has the ability to communicate and adjust settings in the PS Series inverter. It connects into the port labeled **REMOTE CONTROL (SWRC/SWCA)** on the DC side of the inverter using the included DB-25 remote connection cable and is operational whenever DC power is applied to the inverter DC input terminals.

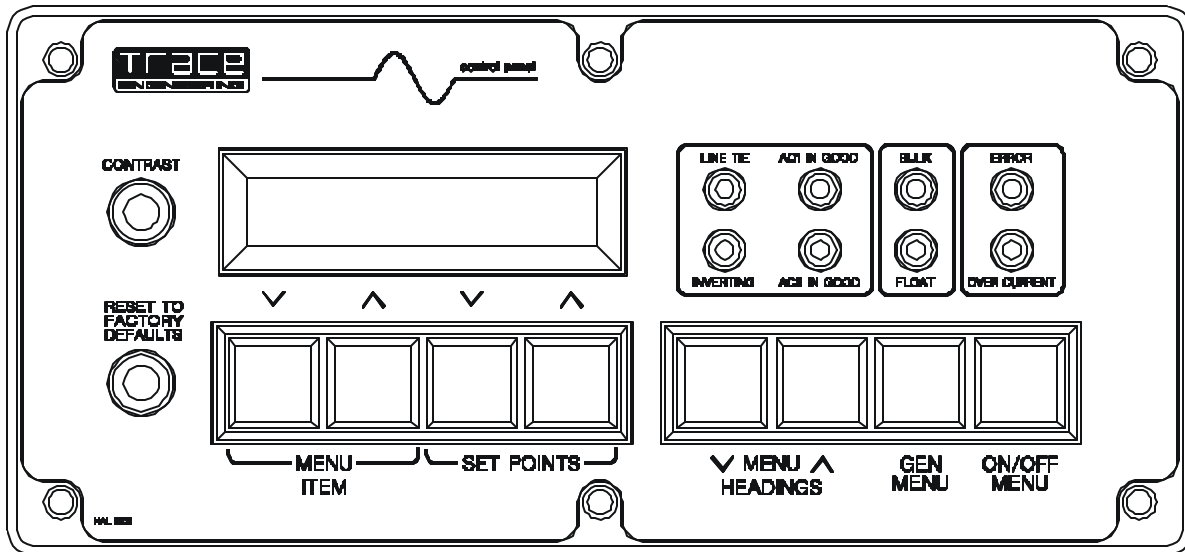

Figure 16, SWRC (Remote Control)

The SWRC displays its information on a Liquid Crystal Display (LCD) screen and eight LED indicators are provided to show the operating condition of the inverter, battery charger, and AC inputs and self-protection systems. The SWRC enables you to configure the inverter/charger to your specific system and preferences, including battery capacity, battery type, maximum charger rate, Low Battery Cutoff and many more operational conditions described in the **OPERATION** section found page 55. In addition, the SWRC enables you to configure the optional **GEN RELAY MODULE** and **AUX RELAY MODULE** described on page 128. The SWRC (or with the SWCA) is the **only** way, at present, to change the setpoints of the inverter. Once the desired changes have been made, the SWRC may be unplugged and these changes will be retained, unless the inverter is disconnected from DC (battery) power. When the SWRC is connected to the inverter, the inverter's LED status indicators still operate normally. The **USER** and **SETUP MENU MAPS** on pages 30 and 31 will help you navigate through the many different menus.

## CONTROLS AND INDICATORS

### CONTRAST ADJUSTMENT

The **CONTRAST** adjustment enables you to adjust the contrast of the LCD display screen to accommodate changing lighting conditions. Less contrast is usually preferable in brighter lighting conditions.

### RESET TO FACTORY DEFAULTS BUTTON

The **"RESET TO FACTORY DEFAULTS"** reset button is provided on the SWRC that returns all of the inverter settings (except for the **'TIME OF DAY'** settings) to the factory default values. The default values will be re-entered only when this button is pushed from a specific menu item in the **USER MENU**. You first must select the **TRACE ENGINEERING (3)** menu heading and then go to the first menu item below, which will display **"PRESS RESET NOW FOR DEFAULTS"**. Once this reset button is pressed from this menu item, you must reprogram all settings required by your installation into the inverter.

Removing DC power from the inverter will also return the inverter to the factory default values (including the 'TIME OF DAY' settings). You must then also reprogram the inverter with the required settings for proper operation of your system. Recording your settings in the **USER MENU** and **SETUP MENU** sections of this manual will make the reprogramming of the inverter much easier.

The reset button can also be used to re-synchronize the remote control display if the characters become jumbled. After connecting the optional SWRC pressing the reset button at anywhere in the menu system (except the **'PRESS RESET NOW FOR DEFAULTS'** menu item) will re-synchronize the display, but the default values will not be reset.

## LED STATUS INDICATORS

The SWRC remote features eight colored LED indicators that identify the various operating conditions of the inverter. Unless otherwise indicated, the LED's will be "solid" in appearance, when illuminated.

### **LINE TIE (YELLOW)**

Selecting **SELL** from the **GRID USAGE** menu item under the **INVERTER SETUP (9)** menu heading will enable sell mode. This should only be done with utility connected systems and after you have received the approval of the local utility. This mode allows excess power to be sent into the utility grid.

### **INVERTING (YELLOW)**

The inverter is operational and AC output is available. If this LED is blinking, then the inverter is in the search mode and is looking for an AC load greater than the **SEARCH WATTS** setting.

### **AC1 IN GOOD (GREEN)**

AC power has been applied and the '**MAXIMUM AC AMP IN**' switch is in the AC1 position. This input is intended for utility power. When an AC source is connected to the input terminals, it will start to blink slowly (once a second) once the AC voltage has been detected. When the inverter has accepted the AC source, the LED will be solid. If the LED starts to blink during operation, then the input AC source has been dropped.

### **AC2 IN GOOD (GREEN)**

AC power has been applied and the '**MAXIMUM AC AMP IN**' switch is in the AC2 position. This input is intended for generator power. When an AC source is connected to the input terminals, it will start to blink slowly (once a second) once the AC voltage has been detected. When the inverter has accepted the AC source, the LED will be solid.

This LED will also blink slowly (once a second) when the automatic generator start system is engaged. When the generator has started, it will continue to blink slowly until the generator has been connected. If the generator does not start, the **AC 2 IN GOOD** LED will stop blinking and the red **ERROR** LED will turn on. The **ERROR CAUSES (5)** menu heading will indicate a **GENERATOR SYNC ERROR** condition.

### **BULK (YELLOW)**

This indicator will be on to indicate the inverter is in the Bulk or Absorption charge stage. This indicator will go off and the **FLOAT** indicator will illuminate when the battery voltage has been held near the **SET BULK VOLTS DC** setting for the time period determined by the **SET ABSORPTION TIME** setting from the **BATTERY CHARGING (10)** menu heading.

If the **EQ** mode is selected from the **SET GENERATOR** menu item under the **GENERATOR MODE (2)** menu heading, the **BULK** LED will slowly blink while the charger completes the equalization process.

# MENU SYSTEM

---

## **FLOAT (GREEN)**

Battery This indicator will be on when the battery voltage has reached the *Float Stage* of the charging process. It will now regulate the charging process to the **SET FLOAT VOLTS DC** setting from the **BATTERY CHARGING (10)** menu heading. The **SET FLOAT VOLTS DC** setting provides a maintenance charge to the battery until another *Bulk Charge Cycle* is initiated or the AC source is disconnected. If a generator is manually controlled and powering the battery charger, the **FLOAT** indicator will come on to indicate that the generator should be turned off, since the battery is now fully charged.

This indicator is also used to indicate the regulation setpoint when the inverter is operating as an Utility Inter-Active Inverter (**SELL mode**). The indicator will blink slowly to indicate the battery is regulated to the **SET BATTERY SELL VOLTS DC** setting from the **BATTERY SELLING (17)** menu heading, and the indicator will be "solid" to indicate the battery is regulated to the **SET FLOAT VOLTS DC** setting from the **BATTERY CHARGING (10)** menu heading.

## **ERROR (RED)**

Indicates that an operating error has occurred (refer to the **ERROR CAUSES (5)** menu heading for a list of possible causes). To reset the inverter, press the red **ON/OFF MENU** button and then select **OFF** and then **ON** with the **SET POINTS** buttons or by pressing the red button several times.

This indicator will blink slowly to indicate that the AC source frequency is not well adjusted (3 to 7 hertz from nominal). You can use the LED blink to help adjust the AC source frequency. Once the frequency is within 3 hertz of your nominal frequency, the LED will turn off.

## **OVERCURRENT (RED)**

The load requirement has exceeded the inverter's maximum output AC amps. A sustained overcurrent condition will require a manual reset by pressing the red **ON/OFF MENU** button and then selecting **OFF** and then **ON** with the **SET POINTS** buttons or by pressing the red button several times. Momentary flashing of the red **OVERCURRENT** indicator means that the inverter has reached its maximum output AC amps and has automatically reset itself. This may occur during motor startups and is acceptable.

## **MENU BUTTONS**

### **ON/OFF MENU BUTTON (RED)**

Pressing the red **ON/OFF MENU** button at any time will take you directly to the **SET INVERTER** menu item of the **INVERTER MODE (1)** menu heading. There are four options available from this menu item. The first letter of the selected item will be underlined by the cursor. Pressing the **SET POINTS** buttons will move the cursor either right or left.

### **GEN MENU BUTTON (GREEN)**

Pressing the green **GEN MENU** button at any time will display the **SET GENERATOR** menu item of the **GENERATOR MODE (2)** menu heading. There are four options available from this menu. The first letter of the selected item will be underlined by the cursor. Pressing the **SET POINTS** buttons will move the cursor either right or left.

### **MENU ACCESS/ADJUSTMENT BUTTONS (BLACK)**

The **MENU HEADING** buttons are used to move either up or down through the selection of menu headings. Once a menu heading is selected, the **MENU ITEM** buttons are used to move up or down through the list of related menu items. The **SET POINTS** buttons change the value of a parameter or select a mode, for the selected menu item.

## USER MENU

This section requires the use of the **SWRC (or SWCA)**. The information in this section is based on using the **SWRC**. In this section, whenever the **SWRC** is mentioned, the **SWCA** may be used instead.

The **USER MENU** provides all the controls and settings needed on a daily basis. It allows you to turn on the inverter and generator, read the AC and DC meters, check on an error cause and even adjust the inverter's time clock.

The **MENU HEADING** buttons are used to move either up or down through the selection of menu headings. Once a menu heading is selected, the **MENU ITEM** buttons are used to move up or down through the list of related menu items. The **SET POINTS** buttons change the value of a parameter or select a mode. Two additional buttons are dedicated for automatically selecting two commonly used menu items. These are **ON/OFF MENU** and **GEN MENU** buttons.

## MENU HEADINGS

Inverter Mode 1	Allows control of the inverter and enables the search and charger only modes.
Generator Mode 2	Allows control of the generator, enables automatic operation or triggers an equalization charge cycle. This menu heading is used only if a generator is included and controlled by the inverter.
Trace Engineering 3	Provides information for accessing Trace Engineering. Also provides the software revision number and allows resetting to the factory default values.
Meters 4	Allows monitoring of the DC battery voltage, AC voltages and AC current of the inverter and other AC sources.
Error Causes 5	Provides an indication of the cause of an error condition. Check this menu heading if the red <b>ERROR</b> LED indicator is illuminated on the <b>SWRC</b> .
Time of Day 6	Sets the internal 24-hour clock. This is used for time sensitive operating modes and to determine the "quiet time" period for generator run lockout.
Generator Timer 7	Used to set a run lockout period called "quiet time". During quiet time, the generator starts only if the battery voltage reaches the <b>LBCO 30 SEC START VDC</b> setting.
END USER MENU 8	Used to display that you have reached the end of the <b>USER MENU</b> .

# MENU SYSTEM

---

## MENU HEADING - INVERTER MODE (1)

Set Inverter
OFF SRCH ON CHG

Allows turning the inverter **ON** and **OFF**, enabling the **SEARCH** mode or selecting the charger only mode **CHG**. The inverter always starts in the **OFF** position when powered up. Pressing the red **ON/OFF MENU** button on the SWRC can also access this display. Use the **SET POINTS** button to move the single space cursor under the desired selection.

- **OFF - Disables the inverter.** When the **OFF** position is selected, no power will be provided to the AC loads even if an AC source is available. This is the default position of the inverter upon power-up.
- **SRCH - Enables the automatic load search mode control system.** This system will turn on the inverter if a large enough load is connected. If not enough AC loads are detected, the **INVERTING** LED will blink slowly. The required AC load level is adjustable with the **SEARCH WATTS** setting in the **INVERTER SETUP (9)** menu.
- **ON - Allows the inverter to provide AC voltage to the output and energize the AC loads either from the battery or from any "synchronized" AC source available on the input.** This position must be manually selected.
- **CHG - Allows the inverter to operate only as a battery charger.** AC power will be available to the AC loads only if an AC source is available and "synchronized". This mode is used to prevent discharge of the batteries by the AC loads when a utility outage occurs. This mode is only operational with the **MAXIMUM AC AMPS IN** switch is in the **AC1** position and when the **SET GRID USAGE** menu item under the **INVERTER SETUP (9)** menu heading is in the **FLT** mode. When a different mode under the **INVERTER SETUP (9)** menu heading is selected, this position will be locked out. Selecting the '**CHG**' mode will disable the Automatic Generator Start features.

### INFORMATION DISPLAY

The following information is displayed as additional Menu Items.

**CHG avail. Only in FLT mode. Press setpoint button to move cursor.  
Move cursor to Inverter OFF to Reset Over Current.**

## MENU HEADING - GENERATOR MODE (2)

Set Generator
OFF AUTO ON EQ

Allows the generator to be turned **ON** and **OFF** or enables **AUTO**-matic and **E**Qualization operation. This menu display always starts in the **OFF** position when the inverter is powered up. Pressing the green **GEN MENU** button on the SWRC can access this display. Use the **SET POINTS** button to move the single space cursor under the desired selection.

- **OFF - Disables the 'auto start' system or turns off a generator that has been started by the inverter.** Also resets the automatic generator start system after an **ERROR** condition has occurred.
- **AUTO - Enables the automatic generator start features.** Allows the generator to be started automatically based on battery voltage, load amps or exercise time. If the generator is started automatically based on battery voltage, the generator will shut off automatically once the battery has completed the **BULK** and **ABSORPTION** battery charging stages. If the generator is started automatically based on load amps, as set in under the **GEN AUTO START SETUP (12)** menu heading, the generator will turn off once the load current has decreased below the **LOAD START AMPS** continuously for the **LOAD STOP DELAY MIN** period. The **AUTO**-matic generator control operation is disabled if the '**CHG**' mode under **INVERTER MODE (1)** menu heading is selected. If the generator is started automatically based on exercise time, the generator will turn off after running for 15 minutes continuously.
- **ON - Starts the generator that is controlled by the inverter.** If this position is selected, it will manually turn on the generator that is connected to the **GEN CONTROL** relays. The **OFF** position must be selected to manually turn the generator off.

**EQ** - Triggers the battery charger to complete the equalization process. If an AC source is connected and the 'MAXIMUM AC AMPS IN' switch is in the **AC1** position, the equalization process will begin. If the 'MAXIMUM AC AMPS IN' switch is in the **AC2** position, the generator will start the equalization process the next time the generator is automatically started. Once the equalization process has been completed, the cursor will return to the **AUTO** position. If you are battery charging - in **FLOAT** charge - from the Utility or a manually controlled generator, you may initiate another **BULK** charge by moving the cursor through **EQ**.

Gen failed to start	NO
---------------------	----

If **YES** is displayed, it indicates that the automatic generator start system was not able to successfully start the generator. The system completes five start cycles and requires that the generator operate for a minimum of 5 minutes before the starting attempts counter is cleared. To manually clear this error, access the **SET GENERATOR** menu item by pressing the green **GEN MENU** button on the SWRC, then select **OFF** and then **AUTO** or **ON** using the set points buttons.

Gen stopped due to V/F	NO
------------------------	----

If **YES** is displayed, it indicates that the automatic generator start system was not able to successfully connect to the generator after it was running. If the generator runs for 10 minutes without operating in the AC Voltage and Frequency tolerance windows, then the automatic start system stops the generator and indicates an error condition. To manually clear this error, access the **SET GENERATOR** menu item by pressing the green **GEN MENU** button on the SWRC, then select **OFF** and then **AUTO** or **ON** using the set points buttons. The acceptable frequency range is 53 to 67 Hertz for 60-Hertz models. The acceptable AC input voltage window is determined by the **INPUT UPPER LIMIT VAC** and **INPUT LOWER LIMIT VAC** settings. See **AC INPUT REQUIREMENTS** on page 63 for more information.

Gen max run time error	NO
------------------------	----

If **YES** is displayed, it indicates that the generator ran for a period of time that exceeded the **SET MAX RUN TIME** menu item setting under the **GEN AUTO START SETUP (12)** menu heading. This error indication will only light to let the user know that the generator ran longer than originally expected. This error LED is an advisory indication only and will not allow the inverter to stop the generator. To disable the **MAX RUN TIME**, set the time to zero. To manually clear this error, access the **SET GENERATOR** menu item by pressing the green **GEN MENU** button on the SWRC, then select **OFF** and then **AUTO** or **ON** using the set points buttons.

Gen speed error	NO
-----------------	----

If **YES** is displayed, it indicates that the automatic generator start system has detected that the generator frequency is within acceptable tolerance, but is not well adjusted. This error condition is an advisory error only. It will cause the red **ERROR** LED to blink, but will not cause the automatic generator start system to shut down the generator.

The **ERROR** LED can be used to adjust the generator frequency. When the frequency is within 3 hertz of the nominal value (57 to 63 for 60 Hz units, 47 to 53 for 50 Hz units), the LED will be off. Once outside this window, the LED will blink slowly. A frequency meter is also provided in the **METERS (4)** menu heading to allow a more precise adjustment of the generator. It is able to indicate the frequency of the generator only after the inverter has been able to synchronize to the generator. The inverter/charger has synchronized with the generator when the **CHARGE** (orange) LED - **BULK** or **FLOAT** LED on the SWRC - has turned on. The acceptable frequency range is 53 to 67 Hertz for 60-Hertz models.

# MENU SYSTEM

---

Load Amp Start ready	NO
-------------------------	----

If **YES** is displayed, it indicates that the automatic start system has started the generator or is about to start the generator because the AC load current has reached the **LOAD AMP START** setting. The automatic start is delayed by the time period set by the **LOAD START DELAY MIN** setting in the **GEN AUTO START SETUP (12)**. This allows checking of why the generator was automatically started.

Voltage Start ready	NO
------------------------	----

If **YES** is displayed, it indicates that the automatic start system has started the generator or is about to start the generator because the DC battery voltage reached one of the **START VOLTS** settings. The automatic start is delayed by the time period of the **START VOLTS** setting involved in the **GEN AUTO START SETUP (12)**. This allows checking of why the generator was automatically started.

Exercise Start ready	NO
-------------------------	----

If **YES** is displayed, it indicates that the automatic start system has started the generator or is about to start the generator because the **EXERCISE PERIOD DAYS** setting has been reached. This allows checking of why the generator was automatically started.

## INFORMATION DISPLAY

The following information is displayed as additional Menu Items.

*Move cursor to GEN OFF to reset generator error. If no start in 5 trys then error.*

*If Gen runs for more than max run time then error. Under/Over speed will cause a Sync (Gen stopped due to V/F) error in 10 minutes*

## MENU HEADING - TRACE ENGINEERING (3)

Press reset now for defaults
---------------------------------

Allows resetting of all menu item settings to the factory default values. This also occurs when the battery is disconnected from the inverter. The **RESET TO FACTORY DEFAULTS** button on the SWRC will only reset the default values if it is pressed while this menu item is displayed. All factory default settings will be reset except for the **TIME OF DAY (6)** clock.

If the **RESET TO FACTORY DEFAULTS** button is pressed while in any other menu item or menu heading, only the SWRC display is reset, no settings will be reset. This is useful for clearing any garbled display information. This may be encountered when a remote display is initially connected or when a remote is used in a high electrical noise environment such as a vehicle application.

Revision	5.0
PS AE	

Displays the software revision. Used to ensure compatibility with other units when stacked, etc.

## INFORMATION DISPLAY

The following information is displayed as additional Menu Items.

**5916 195th St NE Arlington, WA 98223 USA**  
**Ph 360-435-8826 Fax 360-435-2229**



## MENU HEADING - METERS (4)

The current meters provided measure only the real, in phase component of the current. This is the portion of the power that actually uses power from the battery. This allows better estimation of the DC power drawn by the load or the battery charger. This may cause the reading to vary from other AC meters.

Inverter/charger amps AC	00
-----------------------------	----

*All models*  
**Range: -64 to 64**

Reads AC amperage. Positive amps indicate the inverter/charger is charging the batteries. Negative (-) amps indicate the inverter is powering the AC loads and the batteries are being discharged.

Input amps AC	00
------------------	----

*All models*  
**Range: -64 to 64**

Reads total AC current into the AC HOT IN input. The reading is positive (+) if the inverter is drawing power from the utility grid to charge the battery or power AC loads and negative (-) if the inverter is selling power into the utility grid (only available if **SELL** mode is enabled).

Load amps AC	00
-----------------	----

*All models*  
**Range: 0 to 64**

Reads the current that is going to the AC loads. This reading is always positive (+).

Battery actual volts DC	12.6
----------------------------	------

*12 VDC models*  
**Range: 5.0 to 17.5**

Battery actual volts DC	25.2
----------------------------	------

*24 VDC models*  
**Range: 10.0 to 35.5**

Reads the battery voltage. Similar to the voltage reading of a standard DC voltmeter. The actual battery voltage value is used for the **LOW BATTERY CUT OUT**, **HIGH BATTERY CUT OUT**, **LOW BATTERY TRANSFER**, **LOW BATTERY CUT IN** and **BATTERY SELL VOLTS** settings.

Battery TempComp volts DC	12.6
------------------------------	------

*12 VDC models*  
**Range: 5.0 to 17.5**

Battery TempComp volts DC	25.2
------------------------------	------

*24 VDC models*  
**Range: 10.0 to 35.5**

**Note: The BTS must be installed for temperature compensation to be operational.**

Reads the battery voltage after it has been adjusted based on the battery's temperature. This value is used by the battery charger for its regulation settings. The value will decrease from the actual battery voltage if the battery is cold and will increase if the battery is hot, which may give the appearance that the batteries are being overcharged during winter and undercharged in the summertime. This improves the performance of the batteries in cold weather and reduces gassing in hot weather. If you are using a NiCad or other alkaline type battery, be sure to adjust the **SET TEMP COMP** menu item under the **BATTERY CHARGING (10)** menu heading of the **SETUP MENU** to **NiCad**.

Inverter volts AC	120
----------------------	-----

*Standard models*  
**Range: 0 to 255**

Inverter volts AC	230
----------------------	-----

*"E" models*  
**Range: 0 to 510**

Reads the RMS value of the inverter's AC output voltage. When synchronized to an AC source, the inverter AC output voltage would match the AC inputs value.

Grid (AC1) volts AC	120
------------------------	-----

*Standard models*  
**Range: 0 to 255**

Grid (AC1) volts AC	230
------------------------	-----

*"E" models*  
**Range: 0 to 510**

Reads the RMS value of the AC voltage at the inverter's AC HOT IN and AC NEUTRAL IN terminals with the **'MAXIMUM AC AMPS IN'** switch in **AC1** position. This is usually the switch position for the utility grid. Value will drift around before inverter has synchronized.

Grid (AC2) volts AC	120
------------------------	-----

*Standard models*  
**Range: 0 to 255**

Grid (AC2) volts AC	230
------------------------	-----

*"E" models*  
**Range: 0 to 510**

Reads the RMS value of the AC voltage at the inverter's AC HOT IN and AC NEUTRAL IN terminals with the **'MAXIMUM AC AMPS IN'** switch in **AC2** position. This is usually the switch position for a back-up, fuel-powered generator. Value will drift around before inverter has synchronized.

# MENU SYSTEM

---

Read Frequency Hertz	60
-------------------------	----

**60 Hz models**  
**Range: 53 to 67**

Read Frequency Hertz	50
-------------------------	----

**50 Hz models**  
**Range: 43 to 57**

Reads the frequency of the AC source that the inverter is synchronized to. This value may drift around until the inverter has synchronized to the source. Once synchronized, the inverter follows the frequency of the AC source it is connected to.

Read Bulk/EQ timer h:m	00:00
---------------------------	-------

**All models**  
**Range: 00:00 to 23:59**

This display shows how long the charger has been in the absorption or equalization period. Once the voltage has reached just below the **BULK (or EQ)** voltage, the timer starts and counts up to the **SET ABSORPTION TIME (or SET EQUALIZE TIME)** at which time the float charge cycle will begin. This timer is an accumulating or up/down type timer - it counts up while the voltage is near the **BULK (EQ)** setting and counts back down if the voltage drops below the **FLOAT VOLTS DC** setting for a period of time.

## INFORMATION DISPLAY

The following information is displayed as additional Menu Items.

**AC1 & AC2 volts valid only when inverter synced to that input.**

**Batt volt actual is used for LBCO, HBCO, LBX, LBCI, sell volts and gen starting.**

**Batt volt temp comp is used for float, bulk, eq & aux relays.**

## MENU HEADING - ERROR CAUSES (5)

When an error has occurred, the red **ERROR** LED on the SWRC will be illuminated. If a generator error has occurred, this **ERROR** LED will blink slowly. This menu is provided to assist with the investigation into the error cause. If an error condition has occurred, the word **NO** will be changed to **YES**. To reset the error, turn the inverter **OFF** and then **ON**.

Low Battery voltage	NO
------------------------	----

Battery voltage is below the **LOW BATTERY CUT OUT VDC** setting. The inverter has shut off to prevent over-discharge of the battery. Allow the battery to recharge or connect to an AC source such as a back-up generator. The inverter will reset when the battery exceeds the **LOW BATTERY CUT IN VDC** setting.

Low Inverter voltage	NO
-------------------------	----

Your inverter/charger monitors the minimum AC voltage level of the AC output. This assures a continuous supply of quality Alternating Current to your electrical loads. This AC voltage level is determined by the **SET INPUT LOWER LIMIT VAC** setting. If the AC voltage falls below this setting continuously for 32 seconds the inverter disconnects from the loads and turns on the error LED. The cause for this error could be high battery voltage or an excessively large load.

Low AC input voltage	NO
-------------------------	----

Your inverter/charger monitors single cycle voltage problems from the AC source. The low AC voltage level is determined by the **SET INPUT UPPER LIMIT VAC** setting. If the AC voltage falls below this setting the INVERT (yellow) LED on the inverter will flash rapidly and remain on for 3 minutes. This error is an advisory error only and will not drop the AC input.

High Battery voltage	NO
-------------------------	----

The inverter turns off due to a high battery voltage condition determined by the **HIGH BATTERY CUT OUT VDC** setting. This can be caused by the solar array or other charging source not being regulated. Check the controller for proper operation. Some controllers have a “equalize” setting which over-rides the normal operation, allowing the battery voltage to be unregulated. Return the controller to the “normal” setting and check for proper operation. If you are using NiCad type batteries, you will need to increase the **HIGH BATTERY CUT OUT VDC** setting. The inverter will automatically reset once the battery voltage has dropped 1.5 volts below the **HBCO** setting.

High AC input voltage	NO
--------------------------	----

Your inverter/charger monitors single cycle voltage problems from the AC source. The high AC voltage level is determined by the **SET INPUT UPPER LIMIT VAC** setting. If the AC voltage rises above this setting the INVERT (yellow) LED on the inverter will flash rapidly and remain on for 3 minutes. This error is an advisory error only and will not drop the AC input.

Gen failed to start	NO
------------------------	----

If **YES** is displayed, it indicates that the automatic generator start system was not able to successfully start the generator. The system completes five start cycles and requires that the generator operate for a minimum of 5 minutes before the starting attempts counter is cleared. To manually clear this error, access the **SET GENERATOR** menu item by pressing the green **GEN MENU** button on the SWRC, then select **OFF** and then **AUTO** or **ON** using the set points buttons.

Gen stopped due to V/F	NO
---------------------------	----

If **YES** is displayed, it indicates that the automatic generator start system was not able to successfully connect to the generator after it was running. If the generator runs for 10 minutes without operating in the AC Voltage and Frequency tolerance windows, then the automatic start system stops the generator and indicates an error condition. To manually clear this error, access the **SET GENERATOR** menu item by pressing the green **GEN MENU** button on the SWRC, then select **OFF** and then **AUTO** or **ON** using the set points buttons. The acceptable frequency range is 53 to 67 Hertz for 60-Hertz models. The acceptable AC input voltage window is determined by the **INPUT UPPER LIMIT VAC** and **INPUT LOWER LIMIT VAC** settings. See **AC INPUT REQUIREMENTS** on page 63 for more information.

Gen max run time error	NO
---------------------------	----

If **YES** is displayed, it indicates that the generator ran for a period of time that exceeded the **SET MAX RUN TIME** menu item setting under the **GEN AUTO START SETUP (12)** menu heading. This error indication will only light to let the user know that the generator ran longer than originally expected. This error LED is an advisory indication only and will not allow the inverter to stop the generator. To disable the **MAX RUN TIME** set the time to zero. To manually clear this error, access the **SET GENERATOR** menu item by pressing the green **GEN MENU** button on the SWRC, then select **OFF** and then **AUTO** or **ON** using the set points buttons.

Gen speed error	NO
-----------------	----

If **YES** is displayed, it indicates that the automatic generator start system has detected that the generator frequency is within acceptable tolerance, but is not well adjusted. This error condition is an advisory error only. It will cause the red **ERROR** LED to blink, but will not cause the automatic generator start system to shut down the generator.

# MENU SYSTEM

---

The **ERROR** LED can be used to adjust the generator frequency. When the frequency is within 3 hertz of the nominal value (57 to 63 for 60 Hz units, 47 to 53 for 50 Hz units), the LED will be off. Once outside this window, the LED will blink slowly. A frequency meter is also provided in the **METERS (4)** menu heading to allow a more precise adjustment of the generator. It is able to indicate the frequency of the generator only after the inverter has been able to synchronize to the generator. The inverter/charger has synchronized with the generator when the **CHARGE** (orange) LED - **BULK** or **FLOAT** LED on the SWRC - has turned on. The acceptable frequency range is 53 to 67 Hertz for 60-Hertz models.

Over Current	NO
--------------	----

Too large of a load was connected or the AC output wiring was short-circuited. This can occur in inverter or charger mode. To clear this fault, disconnect the loads and restart the inverter. To restart, push the red **ON/OFF MENU** button on the SWRC and then select **OFF** and then **ON** or **SRCH**. Reconnect the loads one at a time to find the load or combination of loads that cause the problem. If the inverter will not restart with all loads and inputs disconnected remove all AC wiring from the terminal block and try to restart again. If it restarts - the problem is with the wiring - refer to the **TROUBLESHOOTING GUIDE** on page 109.

Transformer overtemp	NO
----------------------	----

Heatsink overtemp	NO
-------------------	----

The transformer or power transistors have exceeded their safe operating temperature and the inverter has turned off. When operating as a battery charger, the inverter will reduce its charging rate to prevent overheating. As an inverter, overheating can be caused by attempting to operate too large of a load for too long, a failure of the inverter cooling fans, or that the air flow into or out of the inverter is being blocked. The inverter will automatically reset once it has cooled. While the inverter has shut down, AC power from any AC source will not pass through the inverter to power AC loads. Any power management provided by the inverter will not be able to occur while the inverter is off.

AC source wired to output	NO
---------------------------	----

Reports that an AC voltage source was connected directly to the AC output. This can be caused by improper wiring or incorrect installation of the inverter. Check the AC input and output wiring. This condition is much worse than a short circuit and may cause damage to the inverter. Find the cause and correct the problem before restarting the inverter. A defective AC input relay could cause this condition. To test, disconnect all input wiring from AC HOT IN input and restart the inverter. If the **AC IN GOOD** LED indicator on the SWRC glows, then the inverter's internal relay is defective.

External error (stacked)	NO
--------------------------	----

A problem has occurred with the series interface transistors cable or one of the inverters operated in series. Check the cable for damage and replace it to see if the problem is corrected. Also, check the connecting AC wiring.

## INFORMATION DISPLAY

The following information is displayed as additional Menu Items.

**High/Low AC input voltage error detects single cycle problems with AC source during charge or Sell or pass-thru. Reset in 3 min.**

## MENU HEADING - TIME OF DAY (6)

Provides the reference for any time functions enabled. Does not reset when the “PRESS FOR FACTORY DEFAULTS” button is pressed. Will reset only if DC power is lost.

Set Clock hour 00:00:00
----------------------------

Indicates and allows setting of the hours for the internal clock. This setting is based on a 24-hour clock. It adjusts in 10-minute increments.

Set Clock minute 00:00:00
------------------------------

Indicates and allows setting of the minutes for the internal clock. It adjusts in 1-minute increments.

Set Clock second 00
------------------------

Indicates and allows setting of the seconds for the internal clock. It adjusts in 1-second increments.

## MENU HEADING - GENERATOR TIMER (7)

These settings control the optional Generator Relay Module.

Start Quiet time h:m 08:00
-------------------------------

Generator will not be started during this period unless the actual battery voltage reaches the **LOW BATTERY CUT OUT VDC** setting for a continuous period of 30 seconds. The quiet time period causes the automatic generator start system to ignore the AC load and the 24 Hr, 2 Hr and 15 min battery voltage start settings. The quiet time period is usually set for the sleeping hours.

End Quiet time h:m 08:00
-----------------------------

This setting finishes the quiet time period, allowing the generator to start as required by the settings of the **GEN AUTO START SETUP (12)** menu heading in the **SETUP MENU**. To disable the quiet time, set the start and end times equal.

If the generator exercise timer has reached the **SET EXERCISE DAYS** menu item setting, then the generator will start at this time setting and will run for 15 minutes. If the **SET EXERCISE DAYS** menu item is set for 01, then the generator will start every day at this time. To disable the generator exercise system, set the number of days to zero.

### INFORMATION DISPLAY

The following information is displayed as additional Menu Items.

***Gen doesn't run during quiet time unless batt volts is less than LBCO volts for 30 seconds.  
or load > load start amps. To defeat timers set start = end.***

***If exercise days set to 1 then gen will always start @ end quiet***

# MENU SYSTEM

---

## SETUP MENU

This section requires the use of the SWRC (or SWCA). The information in this section is based on using the SWRC. In this section, whenever the SWRC is mentioned, the SWCA may be used instead.

The **SETUP MENU** provides all the controls and settings needed when installing or adjusting the system. To access the **SETUP MENU**, press both the **red ON/OFF MENU** and **green GEN MENU** buttons on the SWRC at the same time. To exit the **SETUP MENU**, press the **red ON/OFF MENU** button or press the down **MENU HEADING** button until you reach the **USER MENU** (menu headings 1 – 8).

### MENU HEADINGS

Inverter Setup 9	Use to program and adjust the operation of the inverter. Also allows adjustment of how the inverter/ charger mode uses the utility grid.
Battery Charging 10	Use to adjust the operation of the battery charger.
AC Inputs 11	Use to adjust the operating characteristics of the utility grid (AC1) and the generator (AC2) inputs, as determined by the ' <b>MAXIMUM AC AMPS IN</b> ' switch.
Gen Auto Start setup 12	Use to setup the when the automatic generator start system and the maximum run time allowed
Gen starting details 13	Use to adjust the starting sequence of the automatic generator start system.
Auxiliary Relays R9 R10 R11 14	Use to adjust the operation of the auxiliary signal relays for controlling external power sources or system loads.
Bulk Charge Trigger Timer 15	Use to set a time when the battery will be given a bulk charge cycle from the utility grid input. Usually only used when <b>SLT</b> mode is enabled.
Low Battery Transfer (LBX ) 16	Use to set up the transfer voltage setting for the <b>LBX</b> mode.
Battery Selling 17	Use to control the <b>SELL</b> mode when it is used to discharge a battery into the utility grid. Also allows setting of the maximum sell amps.
Grid Usage Timer 18	Use to control when the inverter/charger mode uses the utility grid for the <b>FLT</b> and <b>SELL</b> modes.
Information file battery 19	Provides information about the operation of some settings and meters.
END SETUP MENU 20	Used to display that you have reached the end of the <b>SETUP MENU</b> .

## MENU HEADING - INVERTER SETUP (9)

Set Grid Usage
FLT SELL SLT LBX
—

- FLT - Float will try to maintain the batteries at the float voltage level.** This can be used when the source of power is a utility grid or a generator. When AC power is available, the inverter will complete a full three stage charge cycle and then hold the battery at the float level until the source of AC power is no longer available. This is the default setting and is appropriate for use with stand-alone systems with back-up generators or utility back-up systems. **FLT mode does not sell excess power into the utility grid.** If a DC power source is available and the battery is full, its power will be used to directly power the AC loads connected to the inverter output even though the utility grid is also connected to the loads. If more power is available from the DC source than is required to power the AC loads, the battery voltage will increase above the float level. An external charge control device is therefore required to prevent over charging of the battery.
- SELL – SELL mode enables the inverter to “sell” the excess power to the grid (the ‘MAXIMUM AC AMPS IN’ switch must be in the AC1 position). This mode must have the approval of the local power utility prior to its use.** In the US, utility companies are required by law to purchase any excess power generated by their customers; however, they decide what can be connected and what safety requirements must be met. Be advised: some utilities will be more receptive than others will. The most advantageous configuration is called “NET” metering where only one meter is installed and spins either direction. The purchase and sell prices are equal. “Dual” metering requires two meters and is less desirable since the power you sell is worth only a fraction of the price for the power you purchase. Power from any DC source, such as a solar array, and the battery can be sold. When power from a DC source is available, it will be used to power any AC loads connected to the AC output first. Any excess power available from the system will be sold “into” the utility grid through the AC input terminals with the ‘MAXIMUM AC AMPS IN’ switch in the AC1 position.
- SLT - The silent mode does not maintain the battery at float voltage all the time (the ‘MAXIMUM AC AMPS IN’ switch must be in the AC1 position).** The battery charger only operates for part of each day. AC power from the utility grid is passed through the inverter to the loads 24 hours a day. Once a day, at the time prescribed by the **BULK CHARGE TRIGGER TIMER**, the batteries are given a bulk and absorption charge cycle. The inverter will perform a bulk charge once per day from the grid, charging the battery near the **BULK VOLTS DC** setting until the battery charger has held the battery near the **BULK VOLTS DC** setting for the **ABSORPTION TIME** period setting. The inverter will then go totally silent and will wait for the utility power to fail, or until the next day when it performs another bulk charge. After each power outage, the inverter will perform another bulk charge cycle once the AC source has returned. This is typically used only in utility back-up applications.
- LBX - The low battery transfer mode allows a system to automatically switch between utility connected and stand alone battery operation (the ‘MAXIMUM AC AMPS IN’ switch must be in the AC1 position).** In this mode, the inverter will power the loads from the battery and solar array (or other energy source) until the battery voltage drops to the **LOW BATTERY TRANSFER VDC** setting. It will then connect to the utility grid and the loads will be powered by the utility until the battery voltage - charged by the alternative power source (solar, wind etc.) - reaches the **LOW BATTERY CUT IN VDC** setting. The inverter will then disconnect the utility and power the loads from the battery and any other source of DC power connected. This mode is often used instead of the **SELL** mode because approval from the utility is not required - no power will be sent into the utility distribution system when **LBX** is selected. To use the **LBX** mode, the AC source (Grid) must be connected to AC input and the ‘MAXIMUM AC AMPS IN’ switch is must be the **AC1** position. Transfer to the inverter will not occur if the ‘MAXIMUM AC AMPS IN’ switch is in the **AC2** position. **Caution:** *If the system is not properly sized, the **LBX** mode can result in frequent transfers from the battery to the utility and result in poor performance of the system and excessive energy consumption from the utility. The daily output of the alternative power source (solar, wind etc.) should be able to meet the daily power requirements of the loads being operated under typical conditions. See the Low Battery Transfer mode section for more information.*

# MENU SYSTEM

Set Low battery cut out VDC	11.0
--------------------------------	------

**12 VDC models**  
**Range: 08.0 to 25.5**

Set Low battery cut out VDC	22.0
--------------------------------	------

**24 VDC models**  
**Range: 16.0 to 35.5**

This setting controls when the inverter turns off due to a low battery voltage condition. The inverter will turn off only after this level has been reached for the period of time set by the following item. When the automatic generator start system is used, the generator will be started when the battery voltage has dropped below this value for 30 seconds continuously. This will occur even during the quiet time period. This setting is not temperature compensated.

Set LBCO delay minutes	15
---------------------------	----

**All models**  
**Range: 00 to 255**

This setting controls how long the inverter delays before turning off due to a low battery voltage condition. The inverter will turn off only after the **LOW BATTERY CUT OUT VDC** level has been reached for this period of time continuously. If you are using the automatic generator start system, don't set this delay period shorter than the amount of time it takes the generator to start and connect or the power will go off and then back on when the generator auto starts due to a LBCO condition.

Set Low battery cut in VDC	13.0
-------------------------------	------

**12 VDC models**  
**Range: 00.0 to 25.5**

Set Low battery cut in VDC	26.0
-------------------------------	------

**24 VDC models**  
**Range: 10.0 to 35.5**

This setting controls when the inverter turns back on once it has shut off after the battery reached the **LOW BATTERY CUT OUT VDC** setting. It is also used to control when the system resumes powering the AC loads from the inverter when **LBX** mode is being used. In **LBX** mode, the best performance will often be achieved if this setting is higher than the **BULK** and **FLOAT VOLTS DC** setting in order to reduce cycling of the system. The DC charging sources (wind, solar, etc.) will then have to cause the battery voltage to rise above the charger settings before the system resumes inverter mode operation.

Set High battery cut out VDC	16.0
---------------------------------	------

**12 VDC models**  
**Range: 00.0 to 16.5**

Set High battery cut out VDC	32.0
---------------------------------	------

**24 VDC models**  
**Range: 10.0 to 33.0**

This is the battery voltage at which the inverter turns off. The inverter will automatically restart once the battery voltage has dropped 1.5 VDC below the HBCO setting. This setting is not temperature compensated.

Set search watts	48
---------------------	----

**All models**  
**Range: 00 to 240**

The sensitivity threshold of the search mode circuit is adjustable. If set to zero, it is effectively disabled. The sensitivity is only adjustable in increments of 16 watts.

Set search spacing	59
-----------------------	----

**All Models**  
**Range: 10 to 255**

The length of time between each search pulse is also adjustable. The setting is in cycles. Therefore, a setting of 60 would generate search pulses that are 1 second apart. The range of settings is from 10 to 255 cycles, which equals a search pulse from 6 times a second to once every 4.25 seconds. This adjustment can be used to speed up the response of the search circuit, which will reduce the delay when starting a load. Reducing the spacing increases the power consumption of the inverter when it is in the search mode, reducing the benefit of it. Typically, the default value is acceptable.

*Note: A setting of 255 will disable the inverter Search Mode detection circuit*

## MENU HEADING - BATTERY CHARGING (10)

Note: See the battery section of this manual for recommended settings for different battery types.

Set Bulk volts DC	14.4
----------------------	------

**12 VDC models**  
**Range: 10.0 to 16.0**

Set Bulk volts DC	28.8
----------------------	------

**24 VDC models**  
**Range: 20.0 to 32.0**

Sets the voltage level that will be maintained during the first and second stage of the charging process. This will be the maximum voltage at which the batteries will be charged. This setting will be compensated for the battery temperature if the **BTS** temperature sensor is installed.



Set Absorption time h:m	02:00
----------------------------	-------

*All models*  
**Range: 00:00 to 23:50**

Sets the time period that the batteries will be held near the **SET BULK VOLTS DC** level for the second stage of the battery charging process, this ensures that the battery is well charged. If the automatic generator start system is used, the generator will turn off when the batteries have been held near the **SET BULK VOLTS DC** setting until the **ABSORPTION TIME** period has elapsed. This time is an accumulating or up/down type timer - it counts up while the voltage is near the **BULK** setting and counts back down if the voltage drops below the **FLOAT** setting. This makes the process more reliable and predictable. If the system designer wants to minimize generator operation, a shorter time may be used. If the system designer wants to ensure that the batteries are fully charged before stopping the charging process, then a longer setting may be used. If the **ABSORPTION TIME** is set to zero (00:00) the unit will not provide any absorption charge time and go straight to the float charge stage after reaching near the **BULK** voltage setting.

Set Float volts DC	13.4
-----------------------	------

*12 VDC models*  
**Range: 10.0 to 16.0**

Set Float volts DC	26.8
-----------------------	------

*24 VDC models*  
**Range: 20.0 to 32.0**

Sets the voltage level that will be maintained at the final stage of the charging process. This is important for systems which are connected to utility power since the battery charger will often be in this stage most of the time. This setting will be compensated for the battery temperature if the **BTS** sensor is installed.

Set Equalize volts DC	14.4
--------------------------	------

*12 VDC models*  
**Range: 10.0 to 16.0**

Set Equalize volts DC	28.8
--------------------------	------

*24 VDC models*  
**Range: 20.0 to 32.0**

Sets the voltage level that the batteries will be held during the equalization process. This will be the maximum voltage at which the batteries will be charged. This setting will be compensated for the battery temperature if the **BTS** temperature sensor is installed.

Set Equalize time h:m	02:00
--------------------------	-------

*All models*  
**Range: 00:00 to 23:50**

Sets the amount of time the battery voltage will be held near the **SET EQ VOLTS DC** level before the equalization process is considered to be completed. If the automatic generator start system is used; it will turn off the generator when this timer has reached its setting, and return the cursor from the **EQ** to the **AUTO** position.

Set Max Charge amps AC	20
---------------------------	----

*Standard models*  
**Range: 01 to 25**

Set Max Charge amps AC	10.0
---------------------------	------

*"E" models*  
**Range: 00.5 to 10.5**

Sets the maximum amount of AC input current that the battery charger will use to charge the battery. This can be used to limit the charger output as well. The charger will "back-off" if the combination of AC loads and the charger reaches the **AMPS AC** setting of the **AC INPUT** connected (determined by the 'MAXIMUM AC AMPS IN' switch position) to prevent overloading the source or tripping breakers. This process occurs automatically. **Note: The default setting will vary between models with different continuous power ratings.**

Set Temp Comp LeadAcid	NiCad
---------------------------	-------

*All models*  
**Select: LeadAcid or NiCad**

Allows selection of the battery type for the battery temperature compensation system. This effectively reduces the battery charging set points when the battery is hot and increases them when the battery is cold. This will only occur if the battery temperature sensor (**BTS**) is installed. The setting should be changed from the default setting only if NiCad or Alkaline "type" batteries are used.

Read Bulk/EQ timer h:m	00:00
---------------------------	-------

*All models*  
**Range: 00:00 to 23:59**

This display shows how long the charger has been in the absorption or equalization period. Once the voltage has reached just below the **BULK** (or **EQ**) voltage, the timer starts and counts up to the **SET ABSORPTION TIME** (or **SET EQUALIZE TIME**) at which time the float charge cycle will begin. This timer is an accumulating or up/down type timer - it counts up while the voltage is near the **BULK** (**EQ**) setting and counts back down if the voltage drops below the **FLOAT VOLTS DC** setting for a period of time.

# MENU SYSTEM

## MENU HEADING - AC INPUTS (11)

Set Grid (AC1) amps AC	50
---------------------------	----

*Standard models*  
**Range: 00 to 50**

Set Grid (AC1) amps AC	25.0
---------------------------	------

*"E" models*  
**Range: 00.0 to 25.0**

This setting is used when the **'MAXIMUM AC AMPS IN'** switch is in the **AC1** position. It determines the level in AC amps at which the inverter begins to back-off the battery charger or operates in parallel to reduce the load on the utility grid. Typically, this is set to the size of the AC circuit breaker that feeds the inverter's AC INPUT.

Set Grid (AC2) amps AC	30
---------------------------	----

*Standard models*  
**Range: 00 to 50**

Set Grid (AC2) amps AC	15.0
---------------------------	------

*"E" models*  
**Range: 00.0 to 25.0**

This setting is used when the **'MAXIMUM AC AMPS IN'** switch is in the **AC2** position. It determines the level in AC amps at which the inverter begins to back-off the battery charger or operates in parallel to reduce the load on the generator. Typically this is set to the size of the generator's circuit breaker feeding the inverter's AC input or the maximum output amperage ability of the generator.

Set Input lower limit VAC	108
------------------------------	-----

*Standard models*  
**Range: 80 to 111**

Set Input lower limit VAC	206
------------------------------	-----

*"E" models*  
**Range: 150 to 220**

Sets the lowest voltage at which the inverter is allowed to be connected to the AC INPUT. When the AC input voltage reaches this level, the inverter will stop battery charging and begin to invert in parallel with the AC source to reduce the load. If the voltage drops below this level, the inverter will disconnect and will power the loads from the battery. **NOTE:** Typically the **INPUT LOWER LIMIT VAC** setting will be based upon the minimum AC voltage tolerable by the AC loads.

Set Input upper limit VAC	132
------------------------------	-----

*Standard models*  
**Range: 128 to 149**

Set Input upper limit VAC	254
------------------------------	-----

*"E" models*  
**Range: 238 to 288**

Sets the highest voltage at which the inverter is allowed to be connected to the AC INPUT. This is also the maximum voltage at which the inverter will sell power into the line if **SELL** is enabled. When this voltage is reached the inverter will disconnect and power the AC loads from the battery. If this voltage drops below this setting, the inverter will reconnect the loads to the AC source.

## MENU HEADING - GEN AUTO START SETUP (12)

Set Load Start amps AC	20
---------------------------	----

*Standard models*  
**Range: 00 to 63**

Set Load Start amps AC	10.0
---------------------------	------

*"E" models*  
**Range: 00.0 to 31.5**

Sets the AC load current that will initiate automatic generator start when the current remains above this setting continuously for the **LOAD START DELAY MIN** period. **Note: The default setting will vary between models with different continuous power ratings.**

Set Load Start delay min	05.0
-----------------------------	------

*All models*  
**Range: 00.0 to 25.5**

Sets the time delay period that will initiate automatic generator start when the current remains above the **LOAD START AMPS AC** setting continuously for this time period.

Set Load Stop delay min	05.0
----------------------------	------

*All models*  
**Range: 00.0 to 25.5**

Sets the amount of time that the automatic generator will continue to run after the load current (determined by the **LOAD AMPS AC** meter) decreases below the **LOAD START AMPS AC** setting.

Set 24 hr start volts DC	12.3
-----------------------------	------

*12 VDC models*  
**Range: 00.0 to 25.5**

Set 24 hr start volts DC	24.6
-----------------------------	------

*24 VDC models*  
**Range: 10.0 to 35.5**

Sets a battery voltage that will initiate automatic generator start if the voltage remains below this setting continuously for 24 hours. This setting is not temperature compensated. This 24-hour start is defeated if the **QUIET TIME** under **GENERATOR TIMER (7)** is enabled.

Set 2 hr start volts DC	11.8
----------------------------	------

**12 VDC models**  
Range: 00.0 to 25.5

Set 2 hr start volts DC	23.6
----------------------------	------

**24 VDC models**  
Range: 10.0 to 35.5

Sets a battery voltage that will initiate automatic generator start if the voltage remains below this setting continuously for 2 hours. This setting is not temperature compensated. This 2-hour start is defeated if the **QUIET TIME** under **GENERATOR TIMER (7)** is enabled.

Set 15 min start volts DC	11.3
------------------------------	------

**12 VDC models**  
Range: 00.0 to 25.5

Set 15 min start volts DC	22.6
------------------------------	------

**24 VDC models**  
Range: 10.0 to 35.5

Sets a battery voltage that will initiate automatic generator start if the voltage remains below this setting continuously for 15 minutes. This setting is not temperature compensated. This 15-minute start is defeated if the **QUIET TIME** under **GENERATOR TIMER (7)** is enabled.

Read LBCO 30 sec start VDC	11.0
-------------------------------	------

**12 VDC models**  
Range: 08.0 to 25.5

Read LBCO 30 sec start VDC	22.0
-------------------------------	------

**24 VDC models**  
Range: 16.0 to 35.5

Displays the battery voltage setting that will initiate an automatic generator start if the voltage remains below the setting continuously for 30 seconds. This setting is not temperature compensated. This display is linked and is adjusted by the **SET LOW BATTERY CUT OUT VDC** menu item setting under the **INVERTER SETUP (9)** menu heading. This 30-second start will attempt to start the auto start generator even if the **QUIET TIME** under **GENERATOR TIMER (7)** is enabled

Set Exercise period days	30
-----------------------------	----

**All models**  
Range: 00 to 255

Sets a maximum number of days allowed between operation of the generator. When an internal counter reaches the number of days set, the generator will be started at the **END QUIET TIME** menu item setting. The run time is fixed at 15 minutes. If the generator is manually or automatically operated for 5 minutes at any time during this period, then this counter will reset and the period will start again. If this menu item is set for 1 day, then the generator will start everyday at this time. If the period is set to zero, then the exercise system will be disabled. If the **'MAXIMUM AC AMPS IN'** switch is in the AC1 position, the generator will not be connected to during the exercising operating period.

Set Maximum run time h:m	08:00
-----------------------------	-------

**All Models**  
Range: 00:00 to 23:50

This setting provides an indication that the generator operated excessively after it was automatically or manually started. Once this time period is reached, the error LED will flash and a **GEN MAX RUN TIME ERROR** condition will be indicated in the **GENERATOR MODE (2)** menu heading. This error is an advisory only error and does not stop the generator and the inverter/charger will continue to operate normally. While the error condition exists, the generator can be started manually or automatically. To reset the error condition, press the green GEN MENU button to select **OFF**, then the **AUTO** or **ON**. Setting the time to 00:00 defeats this function.

## INFORMATION DISPLAY

The following information is displayed as additional Menu Items.

**Set Max Run Time to 0 to defeat. Set exercise to 0 to defeat. See menu 9 to set LBCO**

## MENU HEADING - GEN STARTING DETAILS (13)

Relays **RY7** and **RY8** are the available relays labeled on the optional **GEN RELAY MODULE**

Set RY7 Function GlowStop	Run
------------------------------	-----

**All models**  
Select: **GlowStop** or **Run**

Allows Relay 7 (**RY7**) to provide two different generator start routines. The relay labeled **RY7** is used to provide either a **STOP** signal or a **RUN** signal. It can also be used to provide a **GLOW** signal on diesel generators with glowplugs. Note that the left side choice, **GLOWSTOP**, is the default.

# MENU SYSTEM

---

When **RUN** is selected as the function of the **RY7** relay, the **RY7 COM** and **RY7 N.O.** contacts remain closed while the generator is running. The **RY7 N.C.** (normally closed) contact is open (not connected to the common terminal) while the generator is running. When the generator is off, the **RY7 N.C.** terminal is connected to the **RY7 COM** terminal. This configuration is useful for starting a two wire (auto crank) type generator.

When **GLOWSTOP** is selected as the function of the **RY7** relay, the **RY7 COM** and **RY7 N.O.** contacts remain open while the generator is running. The contacts close only when it is time for the generator to be stopped, then re-open. This is useful for generators that require a stop signal to shut down the generator.

The **GLOWSTOP** setting can also be used for diesel generator. This relay can be used to provide both the **GLOW** and **STOP** signals. When this is done the generator will be given both **GLOW** and **STOP** signals before cranking and when stopping.

Set Gen warmup seconds	20
---------------------------	----

**All Models**  
**Range: 16 to 255**

Sets the number of seconds the generator is allowed to warm up before the load is connected and the battery charger started. If the generator is located in a cold location, a longer setting may be required.

Set Pre Crank seconds	10
--------------------------	----

**All Models**  
**Range: 00 to 255**

Sets the number of seconds the system delays closing of relay **RY8** - the start signal relay - once relay **RY7** is closed. See the **AUTOMATIC GENERATOR START MODE** for more information. This period may also be the amount of time that the glow plugs will be on if they are connected to the automatic start system.

Set Max Cranking seconds	10
-----------------------------	----

**All Models**  
**Range: 01 to 15**

Sets the maximum number of seconds the starter will be cranked during the starting sequence by closing relay **RY8**. See the **AUTOMATIC GENERATOR START MODE** for more information.

Set Post Crank seconds	30
---------------------------	----

**All Models**  
**Range: 00 to 255**

Sets the number of seconds the system will delay after completing the start sequence. If the generator has not started, this sequence will be repeated up to 5 times. See the **AUTOMATIC GENERATOR START MODE** for more information. This period is provided to allow the starter motor to cool off. It can also allow generators with built in warm-up delay contactors to provide AC output before the inverter attempts a re-crank cycle.

## MENU HEADING - AUXILIARY RELAYS R9 R10 R11 (14)

Two voltage-controlled relays (RY9 and RY10) and an AC output fault relay (R11) are provided on the optional **AUX RELAY MODULE**. RY9 and RY10 can perform battery voltage related tasks to simplify installations and RY11 engages when there is no AC voltage on the output. RY11 is also available on the **GEN RELAY MODULE**.

These relays are single pole double throw, five amp relays. The terminals used to connect the external wiring and the **COM** (common) terminals of the relays are separated and both the **N.O.** (normally open) and **N.C.** (normally closed) contacts of each relay is provided. The operation of the relays are individually controlled and adjustable. The two auxiliary relays operate independently of inverter/charger status (being on or off). The relay state (engaged or disengaged) is maintained until the **SET AUX RELAY VOLTS DC** setting or the '**SET AUX RELAY VOLTS DC** minus the **HYSTERESIS VOLTS DC**' setting is met, then the relay will change its state. Both the normally open (**N.O.**) and normally closed (**N.C.**) contacts are available for each of these auxiliary relays.

**CAUTION:** These relays are not intended to directly control a load or charging source - rather they can be used to send a signal or operate the coil of another higher amperage device which does the actual switching of the power. **A fuse rated at 5 amps or less should be included to protect each of the relays.** Damage to these relays from overloading is not covered by warranty and requires the inverter to be returned to a repair center. This also applies to the relays that are provided to start a generator.

Set Relay 9	
volts DC	14.5

**12 VDC Models**  
Range: 00.0 to 25.5

Set Relay 9	
volts DC	29.0

**24 VDC Models**  
Range: 10.0 to 35.5

Sets the voltage trip point for the auxiliary relay number 9. When the battery voltage exceeds this setting the relay closes (engages) between the **N.O.** and **COM** terminals. Both the normally open (**N.O.**) and normally closed (**N.C.**) contacts are available for each of these auxiliary relays. This setting is compensated for the battery temperature when the **BTS** is used. There is no intentional time delay on the reaction for this setting; this allows fast response to rapid voltage changes in the system.

R9 Hysteresis	
volts DC	01.0

**All Models**  
Range: 00.1 to 12.8

The Hysteresis Volts DC setting determines the voltage difference between when the relay opens (disengages) and when it closes (engages). This is an "active high" type of control. The relay closes (engages) between the **N.O.** and **COM** terminals when the battery voltage exceeds the **AUX RELAY 9 VOLTS DC** setting and opens (disengages) at this setting minus the **R9 HYSTERESIS VOLTS DC** setting. It will remain open (disengaged) until it again reaches the **AUX RELAY 9 VOLTS DC** setting. (For example, the default setting opens the relay when the voltage exceeds 14.5 VDC and closes when it drops below 13.5 VDC for 12-volt systems). There is an intentional 2-second time delay to reduce cycling.

Set Relay 10	
volts DC	14.8

**12 VDC Models**  
Range: 00.0 to 25.5

Set Relay 10	
volts DC	29.5

**24 VDC Models**  
Range: 10.0 to 35.5

Sets the voltage trip point for the auxiliary relay number 10. This setting is compensated for the battery temperature when using the **BTS**. There is no intentional time delay on the reaction for this setting. This allows fast response to rapid voltage changes in the system.

R10 Hysteresis	
volts DC	01.0

**All Models**  
Range: 00.1 to 12.8

The hysteresis setting for relay number 10. There is an intentional 2-second time delay to reduce cycling.

## INFORMATION DISPLAY

The following information is displayed as additional Menu Items.

**Relay 11 opens on any error condition.**

**R9 & R10 close on batt > setpoint. Open on batt < setpoint – Hys.**

## MENU HEADING - BULK CHARGE TRIGGER TIMER (15)

Set Start Bulk	
time	00:00

**All Models**  
Range: 00:00 to 23:50

Starts the bulk charge process at the time shown. Setting to 00:00 defeats this function. This setting is required when using the **SLT** mode so that the batteries are charged once each day. With the **GRID USAGE TIMER** enabled, the **START BULK TIME** setting should be set near the beginning of the charging time window for best operation. Since the battery will usually be fully charged when this timer setting is reached, the battery charger will usually reach the **ABSORPTION** stage of the charging process quickly and will then hold the battery near the **BULK VOLTS DC** setting for the **ABSORPTION TIME** setting (default time period is 2 hours). This setting does not need to be adjusted if you are using **FLT** mode with a generator. The '**MAXIMUM AC AMPS IN**' switch must be in the **AC1** position to use the '**BULK CHARGE TRIGGER TIMER**'.

## INFORMATION DISPLAY

The following information is displayed as additional Menu Items.

**To disable timer set to 00:00. If grid timer active set bulk time after start charge time.**  
**In SLT mode dont disable this timer. It is daily chg time.**

# MENU SYSTEM

## MENU HEADING - LOW BATTERY TRANSFER (LBX) (16)

Set Low Battery transfer VDC	11.3
---------------------------------	------

**12 VDC Models**  
**Range: 00.0 to 25.5**

Set Low Battery transfer VDC	22.6
---------------------------------	------

**24 VDC Models**  
**Range: 10.0 to 35.5**

This is the voltage at which the inverter transfers the loads from the battery to the utility grid. It is used only with the **LBX** and **FLT** modes. This setting is not temperature compensated. The transfer will occur only if the battery voltage remains below this setting for 20 seconds. The system returns to powering the AC loads from the battery once the battery voltage has reached the **LOW BATTERY CUT IN** setting. The **'MAXIMUM AC AMPS IN'** switch must be in the **AC1** position to use the **'LOW BATTERY TRANSFER (LBX)'** mode.

Set Low Battery cut in VDC	13.0
-------------------------------	------

**12 VDC Models**  
**Range: 00.0 to 25.5**

Set Low Battery cut in VDC	26.0
-------------------------------	------

**24 VDC Models**  
**Range: 10.0 to 35.5**

This setting controls when the inverter turns back on - once it has shut off - after the battery reached the **LOW BATTERY CUT OUT VDC** setting. It is also used in the **LBX** mode - after the **LOW BATTERY TRANSFER VDC** setting has been reached - to control when the system resumes powering the AC loads from the inverter. The DC charging sources (wind, solar, etc.) must raise the battery voltage above this setting before the system resumes inverter mode operation. There is no delay in transfer from the grid back to the inverter after the battery voltage has reached this setting. The **'MAXIMUM AC AMPS IN'** switch must be in the **AC1** position to use the **'LOW BATTERY TRANSFER (LBX)'** mode.

### INFORMATION DISPLAY

The following information is displayed as additional Menu Items.

**See menu 9 to enable LBX mode. Make sure LBX is above LBCO volts.**

## MENU HEADING - BATTERY SELLING (17)

Requires that the **'MAXIMUM AC AMPS IN'** switch be in the **AC1** position.

Note: See the battery section of this manual for recommended setting for different battery types.

Set Battery Sell volts DC	13.4
------------------------------	------

**12 VDC models**  
**Range: 10.0 to 16.0**

Set Battery Sell volts DC	26.8
------------------------------	------

**24 VDC models**  
**Range: 20.0 to 32.0**

Sets the level to which the batteries will be discharge when power is being sold from the batteries to the grid. This is only used if the **SELL** mode is enabled and the **GRID USAGE TIMER (18)** is programmed. This setting will not be adjusted for the battery temperature if the temperature sensor is installed.

Set Max Sell amps AC	20
-------------------------	----

**Standard models**  
**Range: 01 to 25**

Set Max Sell amps AC	10.0
-------------------------	------

**"E" models**  
**Range: 00.5 to 10.5**

Sets the maximum AC amps allowed to be delivered to the utility grid from a solar array and/or the batteries during utility inter-active operation. This setting is only used if the **SELL** mode is enabled. If batteries are being "sold" into the utility grid, this setting together with the **SET BATTERY SELL VOLTS DC** setting determines the depth of discharge the batteries will experience. **Note: The default setting will vary between models with different continuous output power ratings.**

### INFORMATION DISPLAY

The following information is displayed as additional Menu Items.

**See menu 9 to enable SELL mode.**

## MENU HEADING - GRID USAGE TIMER (18)

The Grid Usage Timer selects when power may be drawn from the utility grid for battery charging. It is used only when either the **FLT** or **SELL** modes are selected in the **SET GRID USAGE** menu item under the **INVERTER SETUP (9)** menu heading. Requires that the **'MAXIMUM AC AMPS IN'** switch be in the **AC1** position.

Set Start Charge time	21:00
--------------------------	-------

*All Models*  
**Range: 00:00 to 23:50**

Set End Charge time	21:00
------------------------	-------

*All Models*  
**Range: 00:00 to 23:50**

**FLT mode:** After the **START CHARGE TIME**, the inverter turns on the battery charger, connects the utility grid and powers the AC loads from the utility grid and charges the battery to the **FLOAT VOLTS DC** setting. At the **END CHARGE TIME**, the inverter disconnects from the utility grid and powers the loads from the battery.

**SELL mode:**

- With the **GRID USAGE TIMER** enabled (the **START CHARGE TIME** beginning time is not equal to the **END CHARGE TIME**), the inverter will charge the battery to the **FLOAT VOLTS DC** setting at the **START CHARGE TIME**. After the **END CHARGE TIME**, the inverter turns off the battery charger and begins to "sell" power into the utility grid from the battery (or any other DC sources available and connected to the batteries) to the **SELL VOLTS DC** setting. The current will be limited to a maximum level controlled by the **MAX SELL AMPS AC** menu item setting under the **BATTERY SELLING (17)** menu heading.
- With the **GRID USAGE TIMER** disabled (the **START CHARGE TIME** beginning time is equal to the **END CHARGE TIME**), the inverter will use the utility grid (or any other DC sources available and connected to the batteries) to maintain the batteries to the **FLOAT VOLTS DC** setting.

In the **SELL** mode, battery voltage will be held near the **SET BULK VOLTS DC** setting for the adjustable **ABSORPTION TIME** period setting after an AC failure or upon encountering a **BULK CHARGE TRIGGER TIMER** event.

In either mode, the **SET START BULK TIME** menu item setting under the **BULK CHARGE TRIGGER TIMER (15)** menu heading can be used to increase the battery charging regulation voltage to the **BULK VOLTS DC** setting.

**Note:** By setting the beginning time equal to the ending time, the grid usage timer feature is defeated.

### INFORMATION DISPLAY

The following information is displayed as additional Menu Items.

**After Start Charge time: SELL mode charges battery. FLT mode charges battery.**

**After End Charge time: SELL mode sells battery to AC1, FLT mode drops AC1 and inverts timer on when start <> end. Timer off when start = end;**

**Sell and float modes use timer. SLT and LBX mode ignore timer.**

## MENU HEADING - INFORMATION FILE BATTERY (19)

This Menu Heading provides additional information about the battery charging system. It has no user adjustable settings.

### INFORMATION DISPLAY

The following information is displayed as Menu Items.

**Batt temp comp changes battery voltage reading away from actual HBCO.**

**Resets at: 6v/48, 3v/24 and 1.5v/12 under HBCO.**

**LowBatt Transfer used in LBX, FLT modes only.**

**Goes back to battery at LowBattCutIn (aka LBCI).**

**For LBX mode set float & bulk volts below LBCI so charger won't cycle batteries up and down and set LBCO below LBX.**

**PAGE  
INTENTIONALLY  
NOT USED**



## OPERATION

The PS Series Inverter/Charger can be configured in many different ways: as a simple stand-alone unit, working in conjunction with your generator to handle loads too large for the generator alone, allowing automatic generator start based on battery voltage or loads amp size, or functioning as a utility interactive inverter which will allow you to send excess power back to the utility grid.

These configurations along with numerous additional features, such as: adjustable charge settings and automatic battery temperature sensing with the three-stage battery charger; AC/DC voltmeters and AC ammeters to allow monitoring of inverter, generator, and utility grid; on-board 24-hour clock for programming of generator quiet time and utility inter-active modes; and an adjustable sellback current level when using the utility inter-active mode are all available and can be easily accessed using the SWRC

Often, the inverter will be set-up to operate in several modes at the same or different times - such as operating as an inverter/charger in utility back-up mode with automatic generator start mode and generator support mode during extended utility outage periods. The extensive configurations available are described in the *Operating Modes* chapter that starts on page 58 and will allow you to enhance and customize your inverter's particular operation.

Before operating the PS Series Inverter/Charger, ensure that the unit is installed in accordance with the instructions in the **INSTALLATION** section beginning on page 17.

## THEORY OF OPERATION

The PS Series Inverter/Charger employs a new patented inverter design. This design uses a combination of three transformers, each with its own low frequency switcher, coupled in series and driven by separate interconnected micro-controllers. In essence, it is three inverters linked together by their transformers.

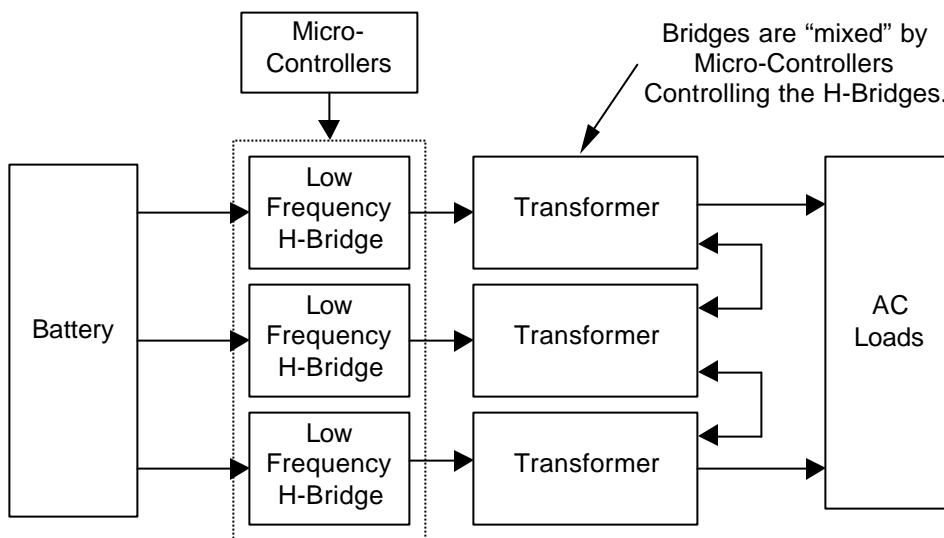

Figure 17, Trace PS Series Inverter/Charger Simple Block Diagram

By mixing the outputs from the different transformers, a sine wave is produced. Shown in Figure 18, is the output waveform from a *Trace Engineering Power Station (PS Series) inverter*. Notice the "steps" form a staircase that is shaped like a sine wave. The total harmonic distortion in this sinewave approach is typically 3-5%. The multi-stepped output is formed by modulation of the voltage through mixing of the transformers in a specific order. Anywhere from 34-52 "steps" per AC cycle may be present in the waveform. The heavier the load or lower DC input voltage the more steps there are in the waveform.

This type of inverter solves many of the problems associated with high frequency or ferro-resonant sine wave inverters. The low frequency method described has excellent surge ability, high efficiency (typically 85 to 90%), good voltage and frequency regulation, and low total harmonic distortion.

# OPERATION

---

The inverter runs in two basic formats: as a stand-alone inverter (converting DC to AC), or as a parallel inverter (with its output synchronized to another AC source). In inverter mode, only 60 Hz (50 Hz for export units) waveforms are created. As the battery voltage rises, waveforms with progressively fewer steps are generated. More steps are used when battery voltage decreases. Since the battery voltage tends to drop with increased load, the waveform has increased number of steps with heavier AC loads.

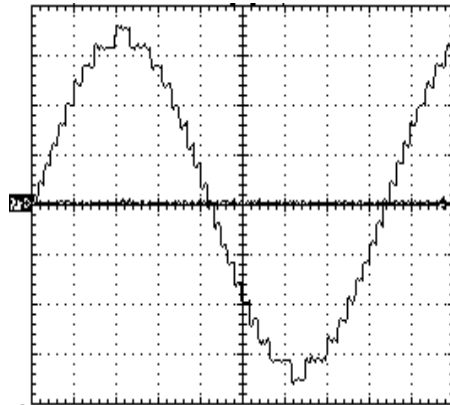

Figure 18, Trace PS Series Inverter/Charger Output Waveform

The inverter is able to synchronize with other AC sources before connecting it to the AC load. The frequency of the AC source is tracked and the inverter constantly adjusts its frequency to maintain a lock. A normally open contactor is used to parallel the inverter's output and the AC source.

The inverter's power topology is bi-directional. If the waveform created by the inverter has a higher voltage than the paralleled AC source, then power flows from the batteries to the load. If the waveform generated has a lower voltage than the AC source, power flows from the source to the battery. The various modes of operation use different algorithms for determining the size of the waveform to be created by the inverter. In battery charger mode, for example, waveforms smaller than the AC source are created to cause current to flow into the batteries. This process is fully regulated to provide a three-stage charge cycle. If the level of AC current exceeds the user programmed generator or grid size, and then the inverter will switch to a generator support mode and create waveforms that are larger than the AC source. This causes power to flow from the batteries to the AC loads to prevent overloading of the AC source.

In utility inter-active mode, the inverter can operate as a battery charger or paralleled AC source to the utility grid. If an external source such as solar panels attempts to raise the batteries above the float voltage setting, the inverter will try to hold the battery voltage at the float voltage level by "selling" the excess power into the utility grid. This is done by increasing the inverter's output voltage level. This moves the excess DC power from the solar array to the AC utility grid, preventing the battery from being overcharged. If the utility grid connected to the inverter is de-energized, the inverter can not regulate the battery voltage. Some external control device must be provided to prevent damage to the battery.

## POWER VS. EFFICIENCY

There are two primary losses that combine to create the efficiency of the PS Series Inverter/Charger. The first is the energy that is required to operate the inverter at full output voltage while delivering no current. This is the no load or idle power. At low power levels, the idle power is the largest contributor to efficiency losses. At high power, the largest source of loss is a result of the resistance in the transformer and power transistors. The power lost here is proportional to the square of the output power. For Example, losses at 2000 watts will be four times higher than losses at 1000 watts.

The efficiency of a typical inverter is greater while operating resistive loads. Inductive loads such as motors are run less efficiently due to the impact of power factor losses.

The efficiency of the PS Series is extremely good (>85%). The inverter reaches high efficiency at very low AC load levels, which is important because the inverter often spends the majority of the time at the lower power range. The high efficiency is maintained over a wide power range. Only when operating at high power levels at or above the continuous power levels does the efficiency begin to drop off. Since this usually only occurs for short periods of time, the impact may be negligible.

If your application involves the inverter powering heavy loads for significant periods of time, selecting a model with a higher continuous power rating and a higher DC input voltage would improve the operation of the system. Since the low power efficiency of all the PS Series is extremely good, oversizing the inverter does not reduce system performance.

## INVERTER CAPACITY VS TEMPERATURE

The current protection circuit in the PS Series Inverter/Charger is temperature compensated, therefore the maximum sized load that the inverter can run changes with temperature. As the temperature of the power devices (FET's) increase, the allowable current is reduced. When the available current is reduced, the capacity of the inverter to run loads is reduced.

The graph below shows the effect temperature has on the inverter's capacity to run loads, notice that the inverter reduces its capacity at temperature above 25 °C. The temperature derating graph assumes that the inverter is at sea level and the airflow to the inverter is unrestricted.

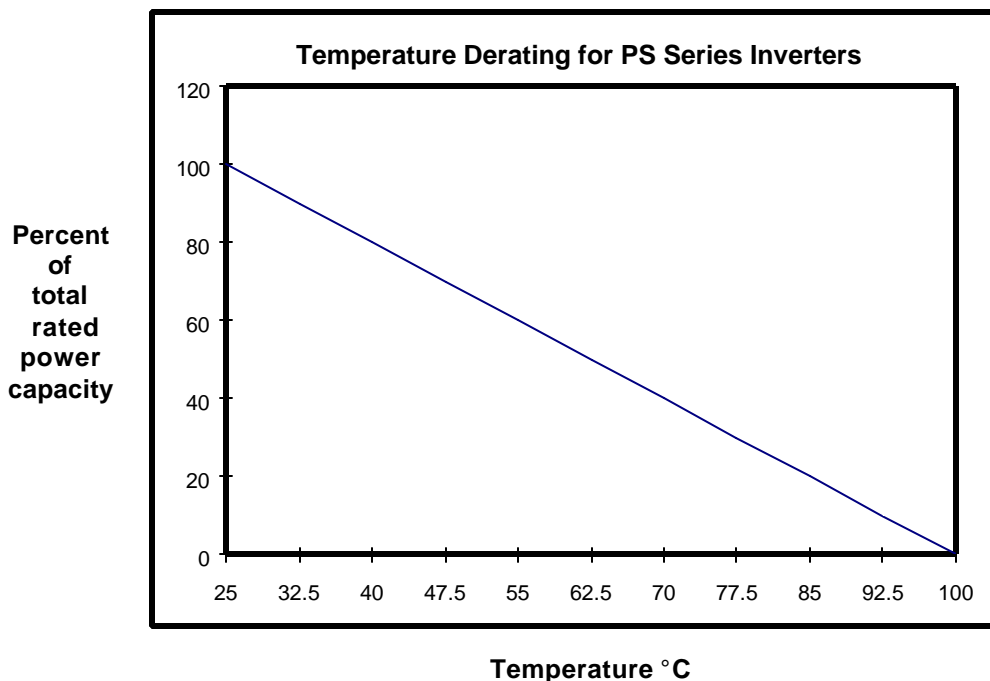

Figure 19, Inverter Capacity vs. Temperature

# OPERATION

---

## OPERATING MODES

The PS Series Inverter/Charger can be used in a wide variety and combination of operating modes:

**NOTE: ALL ADJUSTMENTS AND SETTINGS REQUIRE THE SWRC OR SWCA.**

**INVERTER MODE** - DC to AC inverter with sine wave output, high starting surge, power saving search mode, low idle current, and very high efficiency DC to AC conversion.

**CHARGER MODE** - Low AC current distortion, three stage, temperature compensated, high amperage battery charger.

**INVERTER/CHARGER MODE** - Automatic transfer from inverter to battery charging upon presence of utility or generator AC power source.

**GENERATOR SUPPORT MODE** - Automatic "no glitch" switching from charger mode to inverter mode allowing the inverter to assist the generator in starting and powering large loads. Adjustable generator support current and voltage thresholds.

**AUTOMATIC GENERATOR START MODE** - Automatic generator starting based on the battery voltage reaching an adjustable voltage setting or the AC loads exceeding an amperage setting. Both start conditions include adjustable time delays. Once started, the inverter operates in battery charger mode until battery is charged to the float stage or until the AC load is reduced. The generator is then shut off and the loads are powered from the battery through the inverter. Automatic generator exercising of the generator and adjustable quiet time period to reduce generator operation may be programmed in the setup menu.

**UTILITY BACK-UP MODE** - Phase synchronized fast AC transfer switching for utility back-up power supply applications. Includes adjustable AC transfer voltage and line conditioning ability.

**UTILITY INTER-ACTIVE MODE** - Excess power from charging sources or stored power from the battery can be "sold" back into a utility grid. Also allows selling of the stored energy in the battery during a specific time period.

**ENERGY MANAGEMENT MODES** - Determines how your utility power can be managed.

- **Time of Day Metering Mode** - Onboard clock to set inverter and charger operating time periods. This mode can be used with "time of day" metering to shift energy consumption to off-peak periods.
- **Peak Load Shaving Mode** - Used to limit the draw of AC loads from a utility grid by powering it from the batteries. The batteries are recharged when the AC loads are reduced. This can "level" the load on a utility.
- **Low Battery Transfer Mode** - Automatic transfer of the AC loads from the batteries to the utility when the system reaches an adjustable low battery voltage setting. Independent settings allow control of when the AC loads return to battery once it is recharged.

**ADDITIONAL FEATURES** - Numerous additional features are provided to enhance and customize the inverter's operation for the various operational modes:

- Three-stage battery charging with fully adjustable charge settings and battery temperature sensing.
- AC and DC voltmeters and AC ammeters to allow monitoring of inverter, generator, and utility grid.
- On-board 24-hour clock for programming of generator quiet time and utility inter-active modes.
- Adjustable sellback current level for utility inter-active mode.

## INVERTER MODE



### IN BRIEF

The inverter makes a stepped approximation to a sine wave. The number of steps typically varies from 34 to 52 per cycle. Lower battery voltage and/or higher output power level increases the number of steps. Higher battery voltage decreases the number of steps. Distortion varies from 3% to 5%. The inverter is able to control the AC output voltage, allowing the inverter to also sell power into a utility grid or assist during the operation of heavy loads by operating in parallel with another AC power source such as a engine powered generator.

### SEARCH MODE CONTROL

An automatic search mode circuit is available to minimize the power draw of the inverter when no loads are being operated. This reduces the power consumption from 16 watts with no load to less than 1 watt (when using the default settings). To do this, the output is reduced to pulses of a single AC cycle with an adjustable delay between pulses. These pulses are used to detect the presence of a load. When a load is detected, the inverter's output goes to full 120 VAC output. The sensitivity of the detection circuit and the spacing of the pulses are user adjustable using the SWRC.

This feature can save a considerable amount of power, particularly in smaller systems that do not have loads operating all of the time. In larger systems, this feature may not result in as much savings. If continuous operation of an AC load is required (such as when powering a microwave clock, VCR timer, computer, or fax machine), then using the search mode is not recommended.

To enable the search mode:

#### FROM THE INVERTER

Select **SRCH** by pushing the ON/OFF button until the yellow LED first comes on. Wait for approximately 5 seconds and the yellow LED will begin to flash slowly to indicate that it is search mode. To disable the search mode and enable **ON** mode, press the on the ON/OFF button again (only once).

The yellow **INVERT** LED on the unit indicates inverter status.

- With the unit **OFF**, the LED will be off.
- In the Search mode (**SRCH**), the yellow LED blinks slowly.
- In the Inverter mode (**ON**) with full output voltage, the yellow LED is on solid.
- In the Charger Only mode (**CHG**) the yellow LED will double blink and then pause for a second.

#### WITH THE SWRC

Select **SRCH** mode from the **SET INVERTER** menu item, accessible by pushing the red **ON/OFF MENU** button on the SWRC. Pressing the **ON/OFF MENU** button on the SWRC can also access the **SRCH** mode. It is also located as the first menu item under the **INVERTER MODE (1)** menu heading. To disable the search mode, select **ON** from the **SET INVERTER** menu item. Pressing the **SET POINTS** buttons will move the cursor either right or left

- With the unit **OFF**, the all LED's will be off.
- In the Search mode (**SRCH**), the yellow LED blinks slowly.
- In the Inverter mode (**ON**) with full output voltage, the yellow LED is on solid.
- In the Charger Only mode (**CHG**), the yellow LED is off.

# OPERATION

---

Successful operation of the system utilizing the search mode requires some initial tuning of the search mode settings to match the loads connected in the system. If the loads change significantly, re-tuning of the settings may be required. The benefit of the search mode circuit only is realized if the inverter is able to enter the energy saving search mode for substantial periods of the day. Occasional checking of the yellow **INVERT** LED (**INVERTING** LED on the SWRC) operation should be done to ensure that the search mode is being used when all of the loads are turned off (*it should blink slowly if it is searching for a load*).

## SETTING SEARCH MODE WATTS (REQUIRES THE SWRC)

The search mode is user adjustable to allow fine-tuning of its operation. The settings are located under the **INVERTER SETUP (9)** menu heading in the **SETUP MENU**. The following example explains the operation:

**Example:** With the **SEARCH WATTS** setting at 32, a 50-watt load will bring the inverter to full output voltage. However, a 30-watt load will leave the inverter in its energy saving search mode. If the sensitivity is increased by lowering the setting to 16, a 20-watt load will bring the inverter out of the search mode, while a 5-watt load will not.

When in the search mode, the yellow **INVERT** LED (**INVERTING** LED on the SWRC) will blink slowly and the inverter will make a ticking sound. At full output voltage, the yellow **INVERT** LED (**INVERTING** LED on the SWRC) will stay on and the inverter will make a steady humming sound. When the inverter is used as an uninterruptable power supply, the search mode should be defeated.

**Exceptions: (Murphy's Law) Unfortunately, things don't always work the way the manual says.**

**Example A:** If the **SEARCH WATTS** is set at 32 and a 30-watt incandescent light is turned on, the inverter will detect the light. The initial load of the bulb is much greater than 32 watts when its filament is cold. When the light gets bright, the filament heats up and the light becomes a 30-watt load. Since this is below the setting of 32, the inverter will not detect it and the light will turn off. This can cause cycling of the inverter between on and off.

**Example B:** If the **SEARCH WATTS** setting is 32 and a 40-watt florescent light is turned on, the inverter will not detect the light. The light presents a smaller load than 32 watts until the gas in the florescent tube ionizes and begins to glow. This problem is more common with the non-electronic type fluorescent bulbs.

**Example C:** There are some appliances that draw power even though they are turned off. TVs with instant on circuits, microwave ovens with digital displays and VCRs with clocks are examples. These loads can present a dilemma. If the **SEARCH WATTS** is set higher than the combination of these loads, then an additional load must be used to bring the inverter out of the search mode before the appliances can be turned on. If the **SEARCH WATTS** is set lower than this combination of loads, then the inverter and the loads will be left on. This will put an additional drain on the batteries (three such 15-watt loads would amount to an additional 45 amp/hours per 24 hours in a 24 VDC system). One solution is to turn these items off by using an extension cord with a rocker switch, a switched outlet, or a circuit breaker for the circuit. Unfortunately, this solution does not allow a clock to retain its setting and may cause it to blink constantly while operating.

## SETTING SEARCH MODE SPACING

The **SET SEARCH SPACING** menu item is calibrated in cycles. To test for loads once each second, adjust this setting to 59 (for 60 Hz models); to test for loads about twice a second, adjust the setting to 30. NOTE: The lower the search spacing value – the less time it takes for the inverter to bring up a load. The lower the setting), the greater the power consumption while in the search mode, thus reducing power. The factory default value (59) is acceptable for most applications. The range is from 4 to 255.

## LOW BATTERY PROTECTION

When the actual battery voltage reaches the **LOW BATTERY CUT OUT** menu item setting for the **LBCO DELAY** period, the inverter shuts off to prevent the battery from being over-discharged. If the inverter is setup to automatically start a backup generator (Gen Auto Start Menu), then it will start once the battery reaches the **LBCO** setting for the selected time (30 seconds, etc).

Any of the following three conditions will return the inverter to normal operation:

1. Power is applied to the **AC HOT IN** input terminals, allowing the inverter to operate as a battery charger.
2. The inverter is manually restarted by pushing the red **ON/OFF** button and selecting **OFF** and then **SRCH** or **ON**.
3. Battery voltage rises above the **SET LOW BATTERY CUT IN** menu item setting.

While the inverter is shut off due to the battery reaching the **LOW BATTERY CUT OUT** settings, the red **ERROR** LED will be illuminated. When the battery voltage increases to the **LOW BATTERY CUT IN** setting, the inverter will automatically turn back on and the **ERROR** LED will turn off.

### ADJUSTING THE LOW BATTERY PROTECTION (USING THE SWRC)

There are three settings which are used to prevent overdischarge of the battery. These settings are located under the **INVERTER SETUP (9)** menu heading. See the **SETUP MENU** section for instructions on accessing these settings.

The **SET LOW BATTERY CUT OUT** menu item determines the voltage level that the battery must reach for it to be considered low. The inverter will continue to operate until the voltage has continuously remained below this setting for the time period from the **SET LBCO DELAY** menu item. Once the inverter has shut off, the battery voltage must rise above the value from the **SET LOW BATTERY CUT IN** menu item.

The default **LOW BATTERY CUT OUT** setting may be lower than what is often recommended for many applications by battery manufacturers. It is set to allow maximum performance from the inverter, not to maximize the life of the battery. If the system is properly designed, the inverter should not reach the **LBCO** setting very often. If the system is expected to utilize the **LBCO** control on a regular basis, then increasing this setting is recommended.

# OPERATION

## CHARGER MODE



### IN BRIEF

When AC power is available, the inverter can operate as a very powerful battery charger with low current distortion. Power is drawn over the full AC cycle. This improves the performance with low AC input voltage or with small generators.

The PS Series includes the ability to automatically “back-off” the battery charger to prevent overloading a generator or tripping a circuit breaker when other AC loads are being operated through the inverter. This improves system reliability and allows greater use of the power available. The charger will also be turned off if the AC voltage drops to an adjustable lower limit VAC setting.

### THREE STAGE CHARGING PROCESS

The charging cycle uses three stages. During the initial "Bulk Charge" stage, the inverter charges at maximum rate allowed by the **SET MAX CHARGE AMPS AC** setting. This causes the battery voltage to rise over time. After the battery voltage reaches near the **SET BULK VOLTS DC** setting, the charger starts the second or “Absorption” stage. During this phase, the charge rate is gradually reduced while the battery voltage is held near the bulk voltage setting. This ensures that the battery is fully charged. The final "Float" stage is initiated when the battery has been held near the **SET BULK VOLTS DC** setting for the adjustable **ABSORPTION TIME** period setting. At this point, the battery voltage is allowed to fall to the **FLOAT VOLTS DC** voltage setting, where it is maintained until another charge cycle is initiated. This reduces gassing of the battery and keeps it fully charged. A new three-stage charge cycle is initiated after an AC source is reapplied to the AC HOT input terminals, or daily if the **BULK CHARGER TRIGGER TIMER (15)** is enabled and if AC power is available continuously.

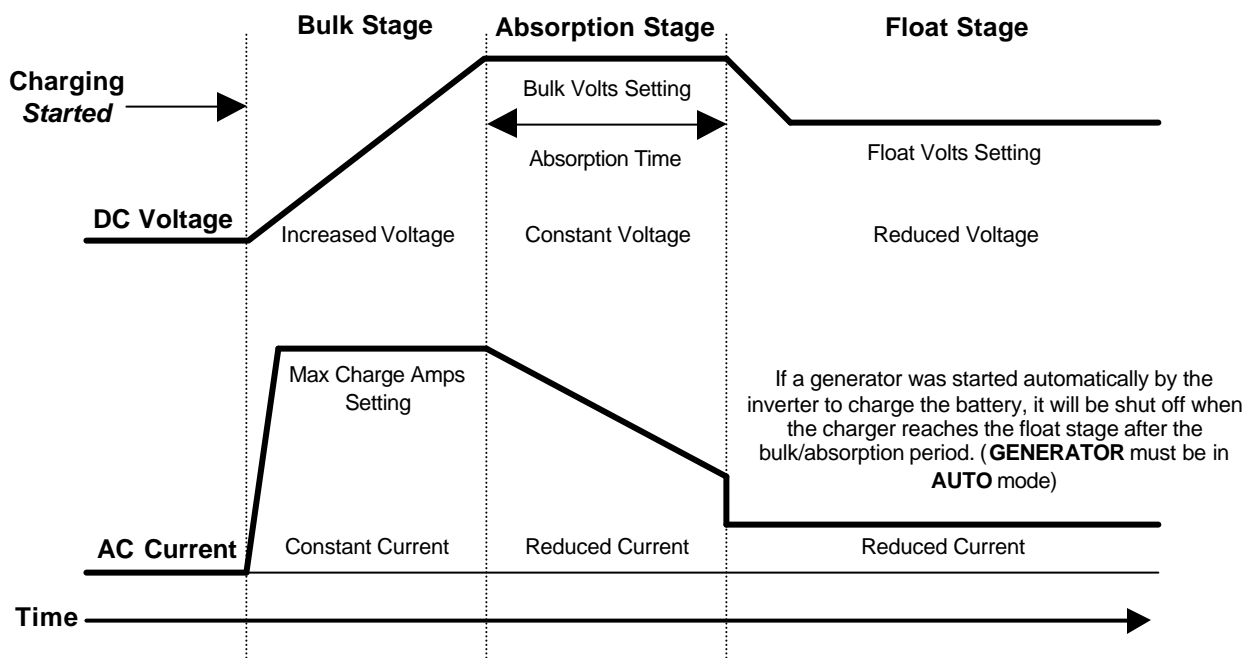

Figure 20, Three-Stage Battery Charging



## BATTERY TEMPERATURE SENSOR (BTS)



Figure 21, BTS (Battery Temperature Sensor)

A plug-in external Battery Temperature Sensor (BTS), which is provided, automatically fine-tunes the charging process of the battery charger in relation to temperature. When the temperature sensor is installed, the charge voltage is adjusted either higher or lower than the **BULK** and **FLOAT** setpoints based on temperature. The **BATTERY TEMP COMP VOLTS DC** menu item under the **METERS (4)** menu heading shows this adjusted charge voltage.

If the temperature sensor is **NOT** installed and if the battery is subjected to large temperature variations, a shorter battery life cycle may be expected.

Install the BTS on the side of the battery below the electrolyte level. It is best if the sensor is placed between batteries and if the batteries are placed in an insulated box to reduce the influence of the ambient temperature outside the battery enclosure. Ventilate the battery box at the highest point to prevent hydrogen accumulation.

The BTS provided may be extended beyond the standard 15 feet by an additional 20 feet using standard telephone cables with RJ-11 plugs. However, locating your batteries more than 35 feet from the inverter exceeds the recommended distance.

## CHARGER ONLY OPERATION

When the **CHG** mode is selected, the inverter will operate only as a charger. This is useful for unattended operation where a power failure might allow the inverter to drain the batteries by powering an AC load unnecessarily. To allow the Charger Only mode, **FLT** must be selected from the **SET GRID USAGE** menu item under the **INVERTER SETUP (9)** menu heading (**FLT** is the factory default setting).

This feature is commonly used in marine applications where the inverter operates a refrigeration system from the batteries. Normally, the engine's alternators keep the batteries charged. When docked, a shore cord is connected to the inverter to power the battery charger and run the refrigerator.

## AC INPUT REQUIREMENTS

The AC source connected to the inverter's **AC INPUT** terminal is used to power both the battery charger and the AC loads while the inverter is in the battery charger mode. There are several settings, listed below, that involve the **AC INPUT**. See *Table 4, AC Input Default Settings* on page 64, or the **USER SETTINGS WORKSHEET** on page 122 for the factory default settings.

### When an AC source is applied to the AC HOT INPUT:

**From the inverter or RC8:** The green **AC IN** LED indicator will come on once the AC voltage has been detected at the **AC INPUT** terminals of the inverter. If the AC source is acceptable, the inverter will synchronize to the AC source after a delay period has passed. Once synchronized, the inverter will close an internal relay to connect the AC source to the AC loads, then the inverter will begin to charge the battery and the orange **CHARGE** LED indicator will come on.

**With the SWRC:** The **AC1 IN GOOD** or **AC2 IN GOOD** LED indicator will blink slowly once the AC voltage has been detected. If the AC source is acceptable, the inverter will synchronize to the AC source after a delay period has passed. Once synchronized, the inverter will close an internal relay to connect the AC source to the AC loads and the inverter will begin to charge the battery indicated by the green **AC IN GOOD** LED indicator turning solid and the orange **BULK** or green **FLOAT** LED indicator turning on.

## INPUT AC VOLTAGE

The **AC1** and **AC2** positions on the **'MAXIMUM AC AMPS IN'** switch settings share the same upper and lower limits for restricting connection to an acceptable AC voltage operating window. The AC input voltage window is typically set to the minimum / maximum range that the AC loads can tolerate - the inverter itself can operate over an extremely wide voltage range. The upper and lower settings are adjustable with the SWRC and are located under the **AC INPUTS (11)** menu heading in the **SETUP MENU**.

# OPERATION

## FREQUENCY

The **AC1** position on the 'MAXIMUM AC AMPS INPUT' switch is intended for Utility Power to be connected to the **AC INPUT**. The frequency tolerance is 53 to 67 Hz for 60 Hz models and 44 to 56 for 50 Hz models. The typical transfer delay is approximately 30 seconds after the AC HOT INPUT terminal is energized. When the **SELL** mode is enabled from the **SET GRID USAGE** menu item, the transfer delay period is typically 90 seconds and the frequency tolerance is restricted to 59 to 61 Hz for 60 Hz models and 49 to 51 for 50 Hz models.

The **AC2** position on the 'MAXIMUM AC AMPS INPUT' switch is intended for a fuel-powered generator to be connected to the **AC INPUT**. There is a default 60-second delay before transfer occurs. This delay gives the generator time to stabilize before being loaded. Frequency tolerance is 53 to 67 Hz for 60 Hz models and 44 to 56 for 50 Hz models. The AC source must be stable for the inverter to synchronize and connect.

## AC CURRENT LEVEL

The maximum current draw into the **AC INPUT** terminals can also be adjusted in the **SET GRID (AC1) AMPS AC** and the **SET GEN (AC2) AMPS AC** menu items using the SWRC. These inputs are used to "back off" the battery charger's AC current draw while other AC loads are being powered through the inverter. This prevents the overloading of the AC source and nuisance tripping of the AC source circuit breakers.

## DELAY PERIOD

With the 'MAXIMUM AC AMPS INPUT' switch in the **AC1** position, the delay period is fixed at approximately 30 seconds after the AC source has been applied. If **SELL** mode is enabled from the **SET GRID USAGE** menu item under the **INVERTER SETUP (9)** menu heading in the **SETUP MENU** and the 'MAXIMUM AC AMPS INPUT' switch is in the **AC1** position, the delay reconnection back to the utility power after an power outage will be for a period of at least 90 seconds. This is not adjustable. The delay allows the utility distribution system to stabilize before the inverter sells power into it after a utility power outage has occurred.

With the 'MAXIMUM AC AMPS INPUT' switch at the **AC2** position, the delay period is adjustable (using the SWRC) through the **SET GEN WARMUP SECONDS** menu item under the **GEN STARTING DETAILS (13)**. This allows the generator to reach a stable operating condition before being loaded. The default generator warm-up period is 60 seconds. Once warmed up, the inverter synchronizes to the generator. If the AC source is not stable, the inverter may not be able to synchronize and will not connect. If the generator runs for 5 minutes without the inverter being able to connect, then the generator will be shut off and the **ERROR** LED indicator will be illuminated. A **GENERATOR SYNC, YES** error condition will be displayed in the **ERROR CAUSES (5)** menu heading on the SWRC.

Table 4, AC Input Default Settings

INPUT PROVISIONS	'MAXIMUM AC AMPS IN' SWITCH POSITION (120 VAC Models)	
	AC1	AC2
Inverter Lower Limit (VAC)	108	108
Inverter Upper Limit (VAC)	132	132
AC Input Current (AC Amps)	50	30
Frequency (Hz)	53 - 67 ( <i>SELL</i> mode = 59 – 61)	53 – 67
Delay Period (seconds)	20 ( <i>SELL</i> mode = 90)	60

INPUT PROVISIONS	'MAXIMUM AC AMPS IN' SWITCH POSITION (230 VAC Models)	
	AC1	AC2
Inverter Lower Limit (VAC)	206	206
Inverter Upper Limit (VAC)	254	254
AC Input Current (AC Amps)	25	15
Frequency (Hz)	43 – 57 ( <i>SELL</i> mode = 49 – 51)	43 – 57
Delay Period (seconds)	20 ( <i>SELL</i> mode = 90)	60

**RECOMMENDED BATTERY CHARGER SETTINGS**

The settings for the battery charger primarily depend upon the battery chemistry and construction. Other factors such as usage, age and battery bank size needs to be considered. The battery charger settings will be automatically adjusted if the temperature compensation sensor is installed. If it is not installed, the settings should be adjusted manually to allow for the typical battery temperature. This may require seasonal readjustment for optimum performance.

The default settings are typical values for liquid, lead acid battery applications. They will work satisfactorily for many systems. **WARNING: To prevent battery damage and achieve maximum performance, adjust the battery charger settings to the manufacturer's recommendations.** NiCad (or alkaline) battery users must also adjust the **SET TEMP COMP** menu item setting; lead acid battery users should use the default value. The battery charger settings are located under the **BATTERY CHARGER (10)** menu heading in the **SETUP MENU**. For access and adjustment to these settings use the SWRC.

Table 5, Battery Charger Default Settings

	12 VDC models	24 VDC models
Set Bulk Volts DC	14.4	28.8
Set Absorption Time H:M	02:00	02:00
Set Float Volts DC	13.4	26.8
Set Equalize Volts DC	14.4	28.8
Set Equalize Time H:M	02:00	02:00
Set Max Charge Amps AC	20*	20*
Set TempComp	LEADACID	LEADACID

\* This default setting will vary between models with different continuous output power ratings. Refer to the User Settings Worksheet starting on page 122 for your particular model.

The **SET MAX CHARGE AMPS AC** menu item will need to be reduced if you are using a small battery bank. High charge rates can cause a small battery to overheat. This may cause damage and is not an efficient way to recharge the battery. With the SWRC, adjust the charger for a maximum rate that is less than 1/5 of the battery capacity for efficient recharging. For example, if the battery is rated at 500 amp-hours, set the maximum charge rate for 100 **amps DC**. Since the setting is adjusted in **amps AC** drawn by the battery charger, divide the DC charge rate by 8 for 12 volt systems and 4 for 24 volt systems. (these factors are for **120 VAC** systems and include the power lost in the battery charger). If the example battery bank of 500 amp-hours was a 24 volt system, the maximum AC amps setting should be around 25 amps AC (500 x 1/5 = 100 amps DC, 100 / 4 = 25 amps AC.)

Once the battery voltage has reached near the **BULK VOLTS DC** setting, the voltage will be held at this level while the current into the battery tapers off. The time allowed for this tapering period is called the **ABSORPTION TIME** period. This setting is very important for systems which use generators since it determines how long a generator will run and when the generator shuts off. Using a generator to “trickle” charge a battery is not efficient and should be avoided. Some users may want to decrease the **ABSORPTION TIME** to keep generator-running time to a minimum. This may result in the batteries not being fully charged. The higher the **BULK VOLTS DC** setting and the longer the **ABSORPTION TIME** period, the more fully charged the battery would be when the charger is shut off. Often, the generator is used too only to **“BULK CHARGE”** the battery and the solar array is allowed to trickle charge the battery to a full condition.

# OPERATION

The following chart provides a guideline in setting the battery charger settings for several different types of batteries. The battery manufacturer is the best source of information and should be consulted if your battery type is not shown. Since the settings also depend on the system design, other factors may apply.

Table 6, Charging Setpoints for Common Battery Types

TYPICAL BULK AND FLOAT SETPOINTS FOR COMMON BATTERY TYPES			
Battery Type	Bulk Volts	Float Volts	Equalizing Charge Process
Sealed Gel Lead Acid battery	14.1 VDC BULK	13.6 VDC FLOAT	Not Recommended - Consult manufacturer
A.G.M. Lead Acid battery	14.4 VDC BULK	13.4 VDC FLOAT	Charge to 15.5 VDC or as per manufacturer
Maintenance-Free RV/Marine Lead Calcium Battery	14.4 VDC BULK	13.4 VDC FLOAT	Not Recommended - Consult manufacturer
Deep-Cycle, Liquid Electrolyte Lead Antimony Battery	14.6 VDC BULK	13.4 VDC FLOAT	Charge to 15.5 VDC or as per manufacturer
NiCad or NiFe Alkaline Battery* (using 10 cells in series)	16.0 VDC BULK	14.5 VDC FLOAT	Consult manufacturer

Note: Values shown are for 12-volt systems. For 24-volt systems, multiply the settings shown by 2. These settings are guidelines, refer to your battery manufacturer for specific settings.

## EQUALIZING CHARGING BATTERIES

In many of the inverter/charger applications, batteries are subjected to less than ideal operating conditions. This can result in significant differences in the state-of-charge level between the individual battery cells. Furthermore, the low charge rates and extended periods at partial charge levels can result in both stratified battery electrolyte and inactive areas of battery plate material. If the condition is allowed to remain for extended periods of time, the battery can "sulfate" and become unusable.

To correct this condition, many manufacturers recommend a periodic "equalization" charge to mix up the electrolyte, re-activate unused battery plate material, and bring up all of the individual cells to a full state of charge. This requires that the battery be given a controlled "overcharge" by increasing the charge voltage for a limited period of time. The voltage and time required are both dependent upon the amount of correction required. The more frequently the batteries are equalized, the lower the equalize voltage and shorter the time period.

Equalizing a battery is only recommended on unsealed or vented batteries. The process will cause the electrolyte to gas and will release hydrogen and oxygen in the process. The chance of explosion due to the accumulation of these gasses is therefore a realistic hazard. The batteries must be provided with good ventilation with no ignition sources present. Some users have found that the battery cell caps are subject to clogging during an equalization charge and therefore remove them during this process. Since the batteries may rapidly bubble while being charged, it is advised that the battery be refilled only after the equalization process is finished (if the battery electrolyte level is low, add enough to cover the plates before charging).

The battery manufacturer or supplier should be consulted before equalizing to provide the recommended process and settings. Every hour the temperature of each battery should be checked by momentarily feeling the battery case with your hand. If the batteries become excessively warm (too hot to keep your hand on) during the equalization process, terminate the charging immediately. Let the batteries cool before checking the need for further equalization charging.

A manual or automatically controlled equalization charge process is available in the PS Series Inverter/Charger. This equalization process can be powered by any AC source. Using the SWRC, the **SET EQUALIZE TIME H: M** menu item under the **BATTERY CHARGING (10)** menu heading sets the amount of time that the battery voltage must exceed the **SET BULK VOLTS DC** setting before the equalization process is considered to be completed. This timer is an accumulating type timer that does not reset if the voltage drops momentarily below the bulk voltage setting. During the equalization process, the voltage will be limited to the level of the **SET EQUALIZE VOLTS DC** menu item under the **BATTERY CHARGING (10)** menu heading.

During the equalization process, the **BULK** LED on the SWRC will flash slowly to indicate that the **EQ** position has been selected from the **SET GENERATOR** menu item.

To start the equalization process (either manually or automatically), you must first select **EQ** from the **SET GENERATOR** menu item, accessible by pressing the green **GEN MENU** button on the SWRC.

To manually equalize your batteries, supply AC power to the **AC HOT INPUT** and **AC NEUTRAL INPUT** terminals with utility power or power from a manually started generator. The inverter will use this power to start the battery charger and begin the equalization process. The **FLOAT** LED on the SWRC will come on to indicate that the equalization process has finished (if the generator or utility power is still available). **Turning on the generator manually will require you to manually shut the generator off when it has finished equalizing.** You must return the cursor to the **OFF** position in the **SET GENERATOR** menu item (accessible by pressing the green **GEN MENU** button on the SWRC) once the equalization period has been completed.

If the automatic generator start system is connected (**MAXIMUM AC AMPS IN'** switch must be set to **AC2** position), the inverter can be set to complete an equalization charge process during the next - automatically started - generator run period. When the generator is automatically started, the equalization process will begin, and once the equalization period has been completed, the generator will automatically stop and display with the SWRC that the cursor has returned to the **AUTO** position in the **SET GENERATOR** menu item.

# OPERATION

## INVERTER/CHARGER MODE

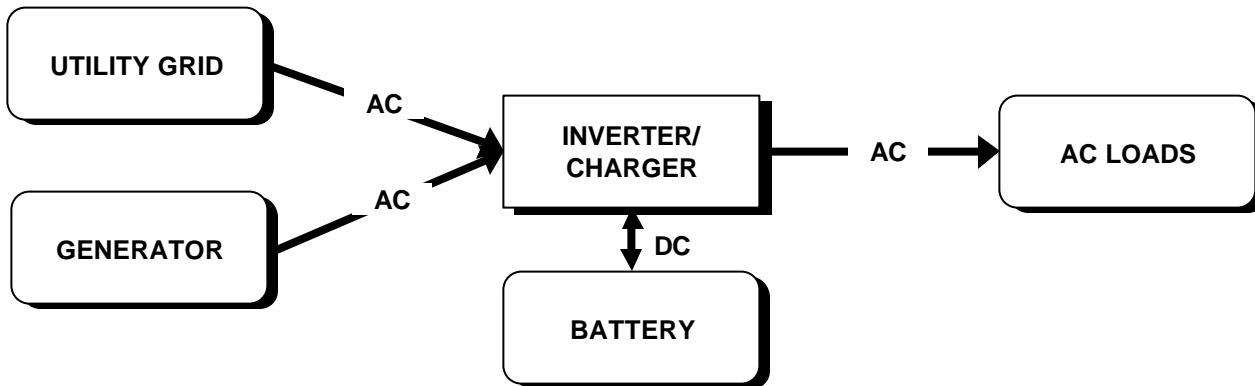

### IN BRIEF

The PS Series is capable of automatically transferring AC loads from the inverter to a utility grid or generator. The inverter/charger can transfer upon the availability of AC power (**FLT** mode - the default) either at a specific time each day (using the **GRID USAGE TIMER (18)** menu heading), or upon a low battery condition (**LBX** mode).

#### TRANSFERRING UPON AVAILABILITY OF AC POWER

When AC power is supplied to the **AC HOT INPUT**, the inverter will automatically transfer from inverter mode to battery charger mode. Before transferring, the inverter will check to see if the AC input voltage and frequency are within tolerance. If AC voltage is acceptable, the inverter synchronizes and connects to the inverter's AC output without interruption of power. Once transferred, the inverter/charger can recharge the battery.

The **FLT** (float) mode is the default mode in the **GRID USAGE** menu item under the **INVERTER SETUP (9)** menu heading and is the proper mode for use with a back-up generator that is being manually or automatically started and for most utility connected applications.

The **SLT** (silent) mode (requires the SWRC to select) is used only if the source of AC power is the utility grid and the '**MAXIMUM AC AMP IN**' switch is in the **AC1** position. In this mode, the only operational difference is that the battery charger will only be engaged for a single period of time each day, set by the **BULK CHARGE TRIGGER TIMER (15)** menu heading setting. This reduces the power consumption of the inverter over the period of a day. It is also used in applications where the slight noise of the inverter might be undesirable, such as at night. AC power continues to be passed through the inverter's transfer relay while the charger is not engaged. If the AC source fails, the inverter will turn on automatically and power the connected AC loads. When utility power returns, the AC loads will be reconnected to the utility and the battery charger will complete a bulk charge cycle if required. Once this has been completed the battery charger will turn off, but the loads will remain connected to the utility.

#### TRANSFERRING BASED ON BATTERY VOLTAGE

If **LBX** (low battery transfer) is selected in the **SET GRID USAGE** menu item under the **INVERTER SETUP (9)** menu heading, the decision to transfer to and from utility power will be based upon the battery voltage. With **LBX** enabled (by the SWRC), the **SET LOW BATTERY CUT IN VDC** setting and the **SET LOW BATTERY TRANSFER VDC** setting determine the DC transfer voltages. When the battery voltage reaches the **SET LOW BATTERY TRANSFER VDC** setting for more than 20 seconds, the AC loads are transferred from the inverter to the utility. At the **LOW BATTERY CUT IN** voltage, the AC loads are transferred from utility to the inverter. The low battery transfer system includes a 20 second time delayed so that large loads are less likely to cause a transfer to the utility grid during motor startup, etc.

While connected to the utility, the battery charger will not be engaged. This is to allow the alternate power source (solar, wind or hydro) to recharge the battery instead of the utility power.

## TRANSFER TIME

Normally there is no transfer time from the inverter to utility power or generator. The inverter operates in parallel with the AC source at all times - even when battery charging. This allows the transfer from inverter to the utility grid or generator to be interruption-free and virtually unnoticeable.

However, in **SELL** mode, when the utility grid fails, the inverter will reach the overcurrent protection system setting (since it will try to power everything that is connected to the grid). The inverter will momentarily shut off while it opens the internal AC input relay. Once the relay has opened, the inverter will begin to operate within a single cycle. This results in a 20-millisecond transfer period. Most AC loads, including computers, will not be affected during the transfer.

# OPERATION

---

## GENERATOR SUPPORT MODE

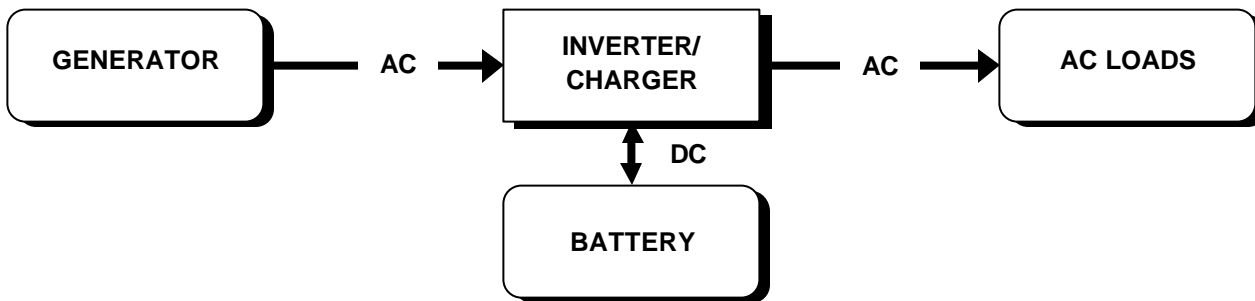

### IN BRIEF

The factory default settings are intended to operate the inverter as an inverter/charger connected to a generator. When the generator is off, the inverter will power the AC loads from the battery. Once the generator is started, the AC loads will be transferred to the generator and the inverter will become a battery charger and store the unused power in the batteries for later use. The inverter will automatically limit the draw of the battery charger to prevent overloading the generator. When the generator is turned off it will be disconnected and the inverter will instantly take over and power the AC loads from the batteries. Generator support does not require that the automatic generator start system be used, but any adjustments will require the SWRC.

To operate in this mode the system must be set-up as follows:

- Connect the generator AC output to the inverter's **AC HOT IN** terminals.
- Set the '**MAXIMUM AC AMPS IN**' switch to the **AC2** position
- Connect the AC loads to the inverter's **AC OUTPUT** terminals.
- Adjust the battery charger parameters to match the requirements of the batteries connected (if the factory defaults listed in the technical section are not satisfactory).
- Adjust the **SET GEN (AC2) AMPS AC** menu item located in the **AC INPUTS (11)** menu heading, to the continuous output ability of the generator. This allows the generator support feature to function correctly, preventing the generator from being overloaded. The generator's output should be derated for altitude and if propane or natural gas is the power source. It is best to error on the low side for this setting, or to experiment with higher settings after the system has been operational.
- Adjust the **SET INPUT LOWER LIMIT VAC** located in the **AC INPUTS (11)** menu heading, to the lowest AC voltage that the AC loads can tolerate. If the generator is pulled down to this level while powering a load, the inverter will back-off its battery charging or even operate in parallel to reduce the load on the generator. Keep in mind that when the inverter supports the generator it uses energy from the batteries to power the AC loads. Therefore, when generator support occurs, the batteries can be discharging instead of recharging even though the generator is running.
- Adjust the **SET INPUT UPPER LIMIT VAC** located in the **AC INPUT (11)** menu heading, to the highest voltage that the generator will be allowed to operate without being considered out of tolerance. At this voltage the inverter will disconnect to protect the AC loads. When the voltage returns to the operating window, the inverter will require a minimum of 20 seconds to re-synchronize and connect the generator to the loads.



## GENERATOR SUPPORT/OVERLOAD PROTECTION

This battery charger is very powerful and without limits could overload a generator. When the generator is running, it has to power both the battery charger and any AC loads connected. If AC charge current combined with any AC load current exceeds the **SET GEN (AC2) AMPS AC** setting (default = 30 amps), the charge rate will be automatically reduced to keep from tripping the generator's output breaker or causing an overload.

If the amount of amperage demanded by the AC loads is greater than the **GEN (AC2) AMPS AC** setting, the inverter's power is able to be added to that of the generator's. The inverter attempts to hold the current drawn from the generator at the setting of the **GEN (AC2) AMPS AC**. This allows the generator to start larger loads than it could normally and reduces the load on the generator during motor start-ups.

Generator support is also available if AC voltage falls to the **SET INPUT LOWER LIMIT VAC**. In this case, the inverter will assist the generator as long as there is power flowing from the generator to the load. This is typically used when a large AC load is being operated and the generator's AC output voltage drops.

For example, if you have a 20 amp generator and the **GEN SIZE AMPS AC** setting is at 15 amps, the inverter will start providing additional power from the batteries whenever the load reaches 15 amps or higher (even though it may not be required). When setting the **GEN SIZE AMPS AC** value, allow for headroom but do not set the value too low.

While the inverter is supporting the generator, the **BULK** or **FLOAT** LED Indicator will remain on even though the inverter may not be battery charging. The **INVERTER/CHARGER AMPS AC** meter will indicate the support process by displaying "negative" current flowing from the inverter to the loads. The **INPUT AMPS AC** will also drop during this process while the **LOAD AMPS AC** remains the same.

### 120 VAC VS. 120/240 VAC GENERATORS

In the US, generators are available with either 120/240 VAC "split phase" or 120 VAC only output. Some generators can be rewired in the field, or have a switch, for changing from one output to the other. If a system uses only one inverter, having the generator put out all of its power at 120 VAC is advantageous. If two inverters are used, having the generator wired for 120/240 VAC output is better.

If you are using one inverter and can not rewire your generator for 120 VAC, or have a combination of 120 and 240 VAC loads which need to be operated, you may need to include a balancing transformer to allow full use of the generator output at 120 VAC. This allows the battery charger to use power from both "halves" of the generator, instead of only half of it. Trace Engineering offers a balancing transformer (Part Number T-240) for this purpose. See the **OTHER PRODUCTS** section on page 129 or contact your inverter supplier for more information.

If your generator can be wired for 120 VAC output and you are using only one inverter, 240 VAC loads can be operated from the system by using a transformer in a step-up configuration. This is common for deep well submersible well pumps. If the step-up is done on the pump side of the pressure switch or manual switch for the pump (run 120 VAC through the switch then step it up to 240 VAC), the transformer will not interfere with using the search mode or increase idle current draw by the inverter when the pump is off.

When two PS Series Inverter/Chargers (AE configured) are operating in a "stacked" configuration (120/240 VAC); each inverter operates as a separate inverter. One inverter can be battery charging with the excess power from one half of the generator, while the other inverter is supporting the generator by operating in parallel to support a heavy 120 VAC load on that half of the system. This allows greater utilization of limited system capacity and is very useful when starting large 120 VAC loads such as water pumps or compressors.

Two 120 VAC/60 HZ inverters can be used to provide 240 VAC. This provides both 120 and 240 VAC since a center "neutral" is provided between the two inverters. If a 240 VAC only AC source is connected to the AC input terminals of the inverter without this center neutral, unacceptable operation will result. To allow connection of a 240 VAC only source, a small (500 VA) autotransformer must be connected across the 240 VAC input and to the AC neutral terminals of the inverters. This will allow the inverter to operate properly. No transformer is required on the AC output side - the 240 VAC can be taken directly from the two AC hot output terminals (one from each inverter).

# OPERATION

## AUTOMATIC GENERATOR CONTROL MODE

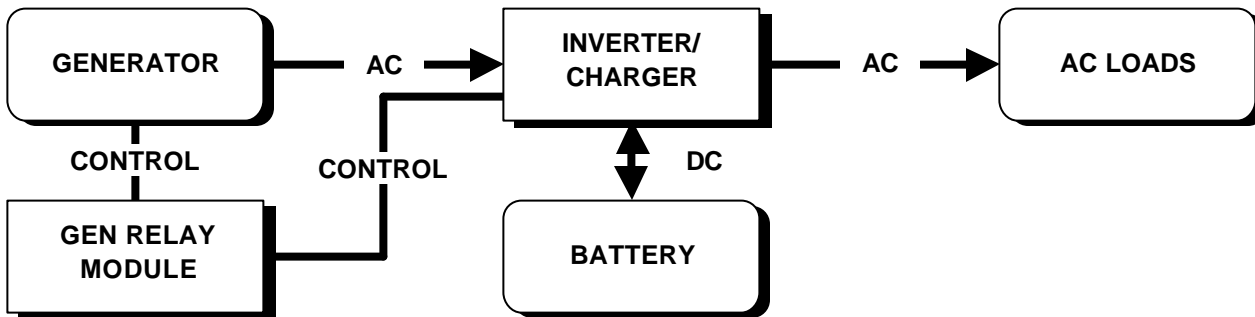

### IN BRIEF

Automatic start/stop control of a back-up generator can be used with any of the other operating modes using the optional **GEN RELAY MODULE**. The SWRC is also required to set-up the different start/stop control sequences through the menu items under the menu headings **GEN AUTO START SETUP (12)**, **GEN STARTING DETAILS (13)** and **GENERATOR TIMER (7)**.

To operate in this mode the system must be set-up as follows:

- Connect the generator AC output out to the inverter's **AC HOT IN** terminals.
- Set the '**MAXIMUM AC AMPS IN**' switch to the **AC2** position. If the '**MAXIMUM AC AMPS IN**' switch is in the **AC1** position, the generator will be started automatically but will not be able to synchronize with the generator.
- Connect the AC loads to the inverter's **AC OUTPUT** terminals.
- Select **AUTO** from the **SET GENERATOR** menu item, accessed by pressing the green **GEN MENU** button. The '**AUTO**' mode is disabled if the '**CHG**' mode under **INVERTER MODE (1)** menu heading is selected.
- Adjust the battery charger parameters to match the requirements of the batteries connected (if the factory defaults listed in the technical section are not satisfactory).
- Adjust the **SET GEN (AC2) AMPS AC** menu item located in the **AC INPUTS (11)** menu heading, to the continuous output ability of the generator. This allows the generator support feature to function correctly, preventing the generator from being overloaded. The generator's output should be derated for altitude and if propane or natural gas is powering it. It is best to error on the low side for this setting, or to experiment with higher settings after the system has been operational.
- Adjust the **SET INPUT LOWER LIMIT VAC** located in the **AC INPUTS (11)** menu heading, to the lowest AC voltage that the AC loads can tolerate. If the generator is pulled down to this level while powering a load, the inverter will back-off its battery charging or even operate in parallel to reduce the load on the generator. Keep in mind that when the inverter supports the generator it uses energy from the batteries to power the AC loads. Therefore, when generator support occurs, the batteries can be discharging instead of recharging even though the generator is running.
- Adjust the **SET INPUT UPPER LIMIT VAC** located in the **AC INPUT (11)** menu heading, to the highest voltage that the generator will be allowed to operate without being considered out of tolerance. At this voltage the inverter will disconnect to protect the AC loads. When the voltage returns to the operating window, the inverter will require a minimum of 20 seconds to re-synchronize and connect the generator to the loads.

## GEN RELAY MODULE

The **GEN RELAY MODULE** connects directly to the PS Series Inverter/Charger to allow starting of many types of generators. It provides two relays labeled **RY7** and **RY8** used to control the generator and two LED indicators to provide status whether the relays have been energized. The **COM** (common) terminals of the relays are separated and both the **N.O.** (normally open) and **N.C.** (normally closed) contacts of the relays are provided.

The relay labeled **RY7** is used to provide either a **STOP** signal or a **RUN** signal. It can also be used to provide a **GLOW** signal on diesel generators with glowplugs. The relay labeled **RY8** is used to provide a crank signal for the starter of the generator engine. It is not used on two-wire type (auto cranking) generators.

**WARNING: All circuits connecting the auto generator control system MUST be protected with fuses rated at 5 amps or less. The warranty does not cover damage to these relays.** All wiring connected to the generator should be fused if any voltage is present at the point of connection. If in doubt, add a fuse. These relays are not intended to directly control the starter motor or operate the ignition system - rather they can be used to send a signal or operate the coil of another higher amperage device which does the actual switching of the power. Fuses should be located as close as possible to the point of connection to the larger conductors that are providing power from the battery. Include a fuse even if the circuit is providing only a "dry contact" or "ground" connection - it will prevent damage if the connection is miswired or if the cable connecting the inverter to the generator is damaged. It is much easier to change a fuse than the entire inverter! For location on where to connect the **GEN RELAY MODULE**, see page 13.

It is much easier to make the connections to the generator if a remote control terminal or connector is available on the generator. This sometimes requires that the generator optional remote control be purchased. This also allows examination of how the generator remote control works - which is what the inverter's generator start system in the inverter must duplicate. Connection of the **GEN RELAY MODULE** to the generator remote control also eliminates any modification that may violate the generator's warranty.

You should also add a switch to allow disabling of the automatic generator start system at the generator to allow local control of the generator, preventing starting while servicing, etc. Many generators include this switch with the optional remote control.

## GENERATOR STARTING SCENARIOS

The generator can be set to start based on the four following scenarios:

### MANUALLY

- (1) **Manual Start** – The generator can be manually started by selecting **ON** from **SET GENERATOR** directory under the **GENERATOR MODE** menu. In manual mode, the generator **MUST** be manually switched OFF by selecting **OFF** from the **SET GENERATOR** menu item.

### AUTOMATICALLY

- (2) **AC Current:** The generator starts whenever the current travelling through the inverter to the AC loads remains above the **LOAD START AMPS AC** setting for the selected **LOAD START DELAY MIN** period. The current can be monitored by the **LOAD AMPS AC** menu item under the **METERS** menu. The generator will start, unless the timer is in the "quiet time" period, at which time it will only start if the **READ LBCO 30 SEC START VDC** setting is reached. Whenever the generator starts automatically, based on load amps, it will shut off once the load current drops below the **LOAD START AMPS** value for the selected **LOAD STOP DELAY MIN** period.
- (3) **Battery Voltage:** The generator starts whenever the battery voltage reaches one of the four adjustable low battery voltage levels for the selected delay periods (24 hours, 2 hours, 15 minutes, or 30 seconds). The low battery voltage levels are set under the **GEN AUTO START SETUP**. Actual battery voltage can be monitored from the **BATTERY ACTUAL VOLTS DC** menu item under the **METERS** menu. The generator will start, unless the timer is in the "quiet time" period, at which time it will only start if the **SET LOW BATTERY CUTOUT VDC** or **READ LBCO 30 SEC START VDC** setting is reached. Whenever the generator starts automatically, based on low battery voltage it will shut off once the **BULK** and **ABSORPTION** stages of the battery charging have completed, thus fully recharging the batteries.

# OPERATION

---

- (4) **Time (Exercise Period Days):** The generator is automatically started at a pre-selected time whenever it exceeds a set number of days without running. Once the start command is initiated, the generator starts and runs for 15 minutes to ensure that it remains fully operational and that the generator's starting battery is maintained at an optimal state of charge. To set generator start time, go to **END QUIET TIME** under the **GENERATOR TIMER** menu. To set the number of days between exercise periods, go to **SET EXERCISE PERIOD DAYS** under the **GEN AUTO START SETUP** menu. If the value is set to 10, the generator will start every tenth day of continuous non-operation. To disable this feature, set the value to zero.

## GENERATOR STARTING AND STOPPING CONFIGURATIONS

Two different generator start routines are available to allow use with a variety of generator types. The sequence of closing and opening of the **RY7** relay, on the **GEN RELAY MODULE**, changes depending upon what position the underlining cursor is in from the **SET RY7 FUNCTION** menu item under the **GEN STARTING DETAILS (13)** menu item. The choices are **GLOWSTOP** or **RUN**.

When **RUN** is selected as the function of the **RY7** relay, the **RY7 COM** and **RY7 N.O.** contacts remain closed while the generator is running. This is usually wired to the ignition system of the generator engine and/or a fuel solenoid valve. The normally closed contacts of this relay are also available on the terminal block, marked **RY7 N.C.** The normally closed contact is open (not connected to the common terminal) while the generator is running. When the generator is off, the **RY7 N.C.** terminal is connected to the **RY7 COM** terminal. This configuration is useful for starting many HONDA brand generators as well as some others. This should also be used to select when the **RY7 COM** and **RY7 N.O.** contacts are used to control a two wire (auto crank) type generator.

When **GLOWSTOP** is selected as the function of the **RY7** relay, the **RY7 COM** and **RY7 N.O.** contacts remain open while the generator is running. The contacts close only when it is time for the generator to be stopped. This is useful for generators that require a stop signal to shut down the generator. The **GLOWSTOP** configuration is useful for starting ONAN brand generators. The **GLOWSTOP** setting can also be used for diesel generators. The **RY7 COM** and **RY7 N.O.** contacts will be closed during the **PRE CRANK SECONDS** period. This relay can be used to provide both the **GLOW** and **STOP** signals. When this is done the generator will be given both **GLOW** and **STOP** signals before cranking and when stopping. This is done on many diesel generators by their own starting systems. You should also check that the control system also powers the glow plugs during the cranking signal - the generator manufacturer or dealer can provide more information.

The terminals marked **RY8 COM** and **RY8 N.O.** provide contacts that remain closed only during generator cranking period. This is usually wired to the starter solenoid (relay) of the generator engine. This relay closes after an initial **PRE CRANK** delay period (the default **MAX CRANKING SECONDS** period is 10 seconds). Relay **RY8** will open after a half-second delay, once the inverter senses an AC voltage above 80 VAC on the **AC INPUT** terminals (the '**MAXIMUM AC AMPS IN**' switch must be in the **AC2** position). If the voltage remains for the **POST CRANK** period, relay **RY8** will remain open. If the generator doesn't start it will close again after a **POST CRANK** delay period. The inverter will attempt to start the generator up to 5 times (the number of times the inverter tries to start the generator is fixed at 5 attempts). If the required voltage level is not reached, relay **RY7** opens (in **RUN** mode) to "kill" the generator before a restart is attempted. This reduces the chance that the starter motor will be engaged on a spinning generator engine. This protection is inherent in the **GLOWSTOP** mode.

The generator will be stopped when the battery charger has kept the temperature compensated battery voltage near the **BULK VOLTS DC** setting for the **ABSORPTION TIME** period. When it is time to stop the generator, relay **RY7** will open or close (depending on which **RY7 FUNCTION** is selected), stopping the generator. This will occur after a 40 second cool down period. If the generator does not stop, the inverter will continue to charge the battery at the **FLOAT VOLTS DC**.

The transfer from generator to inverter will be less noticeable if you manually turn off the generator from the SWRC instead of from the generators off switch. This allows the inverter to first disconnect the generator before it is turned off, reducing problems with voltage sags during the transition.

**GENERATOR CONTROL SEQUENCE**

The relays close in a specific sequence to start the generator. Some of the timing periods are adjustable through the **GEN STARTING DETAILS (13)** menu heading. The two generator control relays complete the following start sequence:

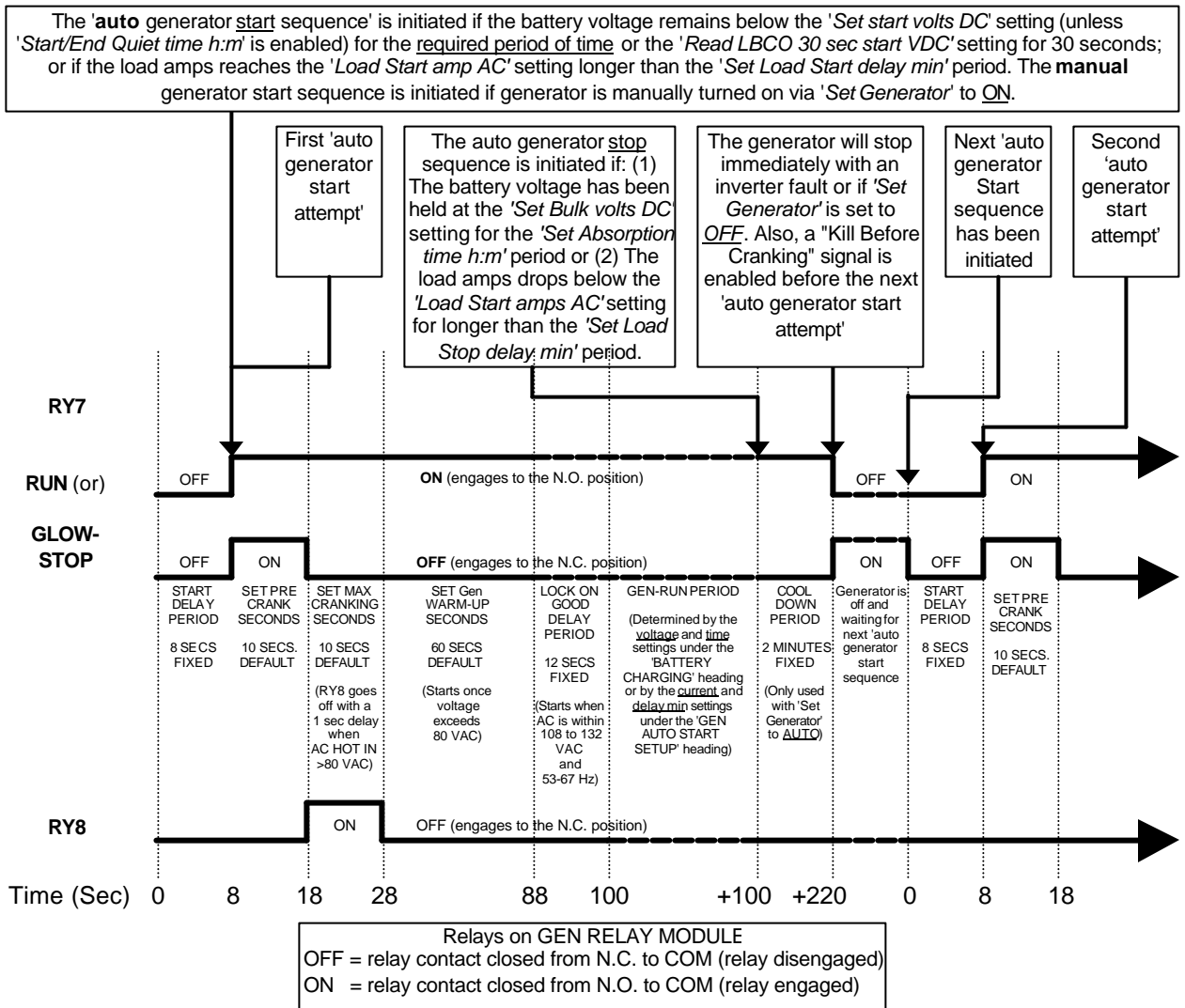

Figure 22, Relay RY7 and RY8 Sequence

# OPERATION

## GENERATOR AUTO START REQUIREMENTS AND TYPES

In order for the generator to be automatically started, it must include electric start and an automatic choke. An automatic primer system may also be required on natural gas and propane powered generators. The generator should also include remote start ability with accessible remote start terminals or a connector. Protective systems for low oil pressure, over temperature, starter lockout and over crank control are valuable features that will prevent generator damage and increase system reliability. "Two wire" start generator are recommended highly because of the greater simplicity for automatic starting and because they are intended for remote/automatic/unattended operation.

Generators used can be fueled by gasoline, propane or diesel fuel. Propane is often the best choice for residential applications due to the ease of fuel storage and delivery, cost, safety, and ease of starting. Since propane is required for the cooking stove, water heater and space heating as well, most residential applications will already have a tank and propane service. Gasoline is also common, but can be difficult to transport and store on site safely. Most small generators do not hold much fuel in their built-in tanks - refitting the generator to use marine outboard motor type fuel tanks is often a good solution for limited fuel capacity. This eliminates the need to pour fuel into the tank of a hot generator - which can be very dangerous. Diesel is a much safer fuel to use and store. Diesel generators can operate with very little maintenance and have very long lives. The only problems with diesel are the higher initial cost, difficulty with starting in cold weather and possible need for the additional control of the glow plugs before starting.

Generators can be either air or water-cooled. Water-cooled units are usually more quiet but can require more maintenance. Low speed (~1800 / 1500 rpm) generators are preferred by many system designers as they often provide longer life due to less mechanical wear and tear.

### TWO WIRE START GENERATORS

Generator starting requirements can be divided into two categories – **two-wire start** types and **three-wire start** types. The two wire start type generator is simpler and the easiest to automate. To start, simply connect the two "remote control" wires together and it starts. The generator provides its own cranking control circuit for start-up. To stop, simply disconnect the two wires. The wires can be connected by a switch or relay. To enable automatic start, connect the two wires from the generator to Relay **RY7 COM** and **RY7 N.O.** of the inverter and connect the generator output to AC 2 input of the inverter. Two wire start generators are specifically designed for unattended operation and usually include all of the safety and protection devices from the factory. They are highly recommended due to the ease of hook-up and troubleshooting that they allow.

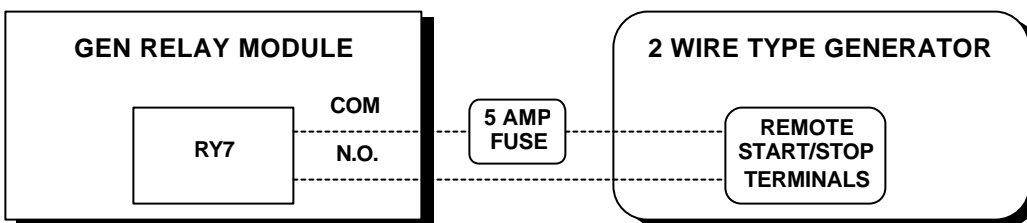

Figure 23, Two-Wire Start Wiring Diagram

When a two-wire start type generator is used, multiple loads can signal the generator to run. A good example is a float switch in a water storage tank. When the water level drops, the float switch closes a set of contacts, which signals the generator to run. When the tank is full, the float switch opens its contacts and the generator stops. The float switch can be used in parallel with the automatic start system of the inverter. Either "switch" can start the generator. This allows easy automation of the entire system.

For this type of generator, select **RUN** from the **SET RY7 FUNCTION** menu item under the **GEN STARTING DETAILS (13)** menu heading. This is the default setting of this menu item.

### THREE WIRE START GENERATORS

**Three wire start generators do not include automatic engine cranking control system.** Separate control of the starter motor is required. This requires more interaction between the inverter's auto-start system and the generator. This also adds complexity to the installation since more wires must be connected and more programming of the inverter is required. Troubleshooting can also be more difficult.

The automatic start system controls the starter much like a person does when starting a car engine. The starter is turned on for short periods of time and then turned off. If the engine starts up while cranking, the starter is turned off after a 1/2-second delay. If the engine does not start, the starter is turned on again after a delay period. This is repeated until either the generator starts or the maximum number of start attempts is reached.

The common term “three wire start” may be misleading - the actual number of wires used may be four or more. It simply means that control of the starter motor is done separately from the generator. Most three wire start generators are not designed for automatic, unattended operation. The generator supplier should be consulted regarding additional safety components required for your installation. The automatic start system only provides the starting and stopping signals based on what the batteries need. It will not shut off the generator if a problem such as low oil pressure occurs.

Three wire start type generators can be divided into two basic types - “Honda” types and “Onan” types. The Honda type uses an automotive type starting circuit as previously discussed. Operating a switch that is first turned to “RUN” and then momentarily held to a “START” position starts it. Once the engine has started, the switch is released and it returns to the “RUN” position. To shut down the generator, the switch is placed in the “OFF” position. For this type of generator, relay **RY7** duplicates the “RUN” position and relay **RY8** duplicates the “START” position, cranking the starter motor.

For this type of generator, select **RUN** from the **SET RY7 FUNCTION** menu item under the **GEN STARTING DETAILS (13)** menu heading. This is the default setting of this menu item.

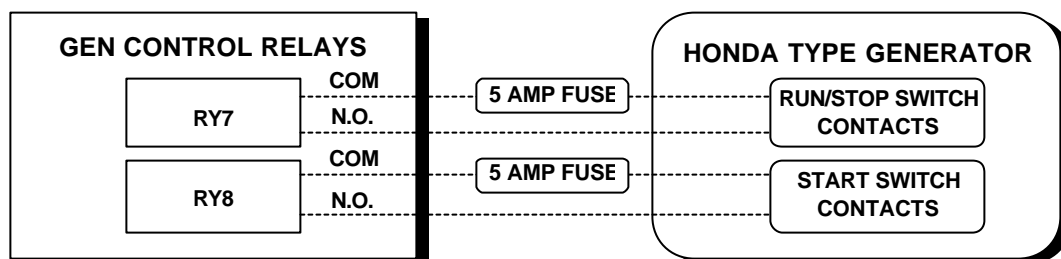

Figure 24, Three Wire Start Wiring Diagram (HONDA Type)

Onan type generators use a different starting sequence. Most Onan type generators use a three-position momentary type switch that controls their operation. To start the generator, the switch is held to the “START” position. This energizes the ignition system and cranks the starter motor. Once the engine has started the switch is released and it returns to a center off position. The starter motor then stops cranking but the ignition system remains energized. To shut down the generator, the switch is held to the “STOP” position until the engine dies. Once the handle is released, it returns to the center position. For this type of generator, relay **RY8** duplicates the “START” position and relay **RY7** is used to duplicate the “STOP” position (using the common and normally open contacts). Some generators use a similar system with two push button switches - one to start and one to stop.

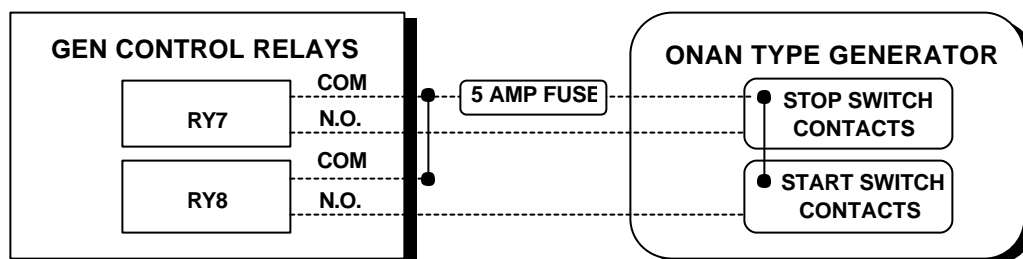

Figure 25, Three Wire Start Wiring Diagram (ONAN Type)

Most diesel generators are controlled like the Onan type, except that they also require that glow plugs be operated before the generator start is attempted. The PS Series automatic generator start system can also provide glow plug control. The addition of a relay may be required to operate the glow plugs due to the amperage required by the glowplugs and to separate the stop signal circuit.

For this type of generator, select **GLOWSTOP** from the **SET RY7 FUNCTION** menu item under the **GEN STARTING DETAILS (13)** menu heading.

# OPERATION

---

## 3-TO-2 WIRE CONVERTERS

Another option for three wire start type generators is to use a 3-to-2-wire converter. These vary from very simple relay types to very advanced microprocessor types. Onan offers a simple 3-to-2-wire converter for some of their generators that have worked well for many installations. Universal 3-to-2 wire converters, can be used with virtually any generator and can control glow plugs as well for diesel generators. These can also allow additional system components to signal the generator start system to start.

## STOP COOL DOWN PERIOD

When the generator stop system is used to stop the generator automatically, the generator is disconnected from the inverter first by opening the AC relay inside the inverter. This allows a very clean transition from the generator to the inverter. The STOP signal is provided immediately if the generator is manually shut off from the SWRC. If the generator is shut off automatically the generator will be allowed to run for an additional 40 seconds before the STOP signal is provided. This allows the generator to cool down before it is turned off. This is very important for turbocharged generators as it allows cooler oil to reach the turbo. If the generator does not stop after the 40 second cool down period when the stop signal is sent, then the inverter will reconnect to the AC source and remain connected as long as it is available.

If the generator is stopped manually from the SWRC, the generator is stopped immediately with no cool down.

## GENERATOR MAX RUN TIME

An adjustable setting is provided to indicate excessive operation of the generator. This setting is intended to indicate excessive generator operation if the system has not been able to fully charge the battery. Operating heavy loads while charging, an unstable generator or even low electrolyte levels in the battery can cause this. If the default value results in repeated error conditions, then increasing the setting may be necessary for your application. This may occur with systems that have very large batteries that require long charge periods or systems with small generators that have limited battery-charging ability. When using the automatic generator start system to complete a equalization cycle, the additional time required for the **EQ** cycle should be considered in order to prevent reaching the **SET MAXIMUM RUN TIME** menu item setting and causing a **GEN MAX RUN TIME ERROR**. The generator does not stop when a **GEN MAX RUN TIME ERROR** has occurred.

## EQUALIZATION CHARGING WITH THE AUTOMATIC GENERATOR START SYSTEM

A manual or automatically controlled equalization charge process is available in the PS Series inverter. To start the equalization process, select **EQ** from the **SET GENERATOR** menu item, accessible by pressing the green **GEN MENU** button on the SWRC. This equalization process can be powered by any AC source. If the AC input is energized by utility power or a manually started generator, the inverter will use it to power the battery charger and start the equalization process. **Turning on the generator manually will require you to manually shut the generator off when it has finished equalizing.**

If the automatic generator start system is connected ("MAXIMUM AC AMP IN" switch must be in the **AC2** position), the inverter can be set to complete an equalization charge process during the next generator run period. You must first select **EQ** from the **SET GENERATOR** menu item. The generator will start the equalization process the next time the generator is automatically started and will automatically stop and return the cursor to the **AUTO** position in the **SET GENERATOR** menu item once the equalization period has been completed.

The **SET EQUALIZE TIME** menu item under the **BATTERY CHARGING (10)** menu heading sets the amount of time that the battery voltage must exceed the **BULK VOLTS DC** setting before the equalization process is considered to be completed. This timer is an accumulating type timer that does not reset if the voltage drops momentarily below the bulk voltage setting. During the equalization process, the voltage will be limited to the level of the **SET EQUALIZATION VOLTS DC** menu item.

During the equalization process, the **BULK** LED will flash slowly to indicate that the **EQ** position has been selected from the **SET GENERATOR** menu item. When the process has finished, the **FLOAT** LED will be on if the generator or utility power is still available.



## GENERATOR EXERCISING

The automatic generator start mode also includes an automatic generator exercising system that sets a maximum number of days allowed between operation of the generator. After the automatic generator exercising start command is initiated, the generator will start and run for 15 minutes every **EXERCISE PERIOD DAYS** since the last time the generator was operated. The number of days between exercise periods is adjusted under the **GEN AUTO START SETUP (12)** menu heading. If the **EXERCISE PERIOD DAYS** menu item is set to one, then the generator will start every day at the end of the "quiet time" period, as long as the generator was not operated during this period. To disable the automatic generator exercising system, set the **EXERCISE PERIOD DAYS** menu item to zero.

If the generator does not run for at least 5 minutes, the automatic start system will consider it a failed attempt and it will restart the generator. After 5 attempts, it will indicate a **GENERATOR START ERROR** in the **ERROR CAUSES** menu heading and the red **ERROR** light will turn on. To clear the error, select **OFF** from the **SET GENERATOR** menu item, accessed by pressing the green **GEN MENU** button.

## GENERATOR ERROR CAUSES

The automatic start system will attempt to start the generator 5 times by closing the starting relay **RY8** until it reaches its **MAX CRANKING SECONDS** setting or the inverter senses an AC voltage above 80-volts AC on its on the **AC HOT INPUT** terminal (**MAXIMUM AC AMPS IN'** switch must be in the **AC2** position). Once the inverter senses 80 volts AC on the **AC HOT INPUT** terminal it will open after a half-second delay and the attempts counter will be reset to zero after successfully running for 5 minutes. If the generator dies within the 5-minute period of being started, the inverter will attempt to restart the generator. The unsuccessful run will be considered a failed start attempt. After 5 start attempts, the **ERROR** LED will be illuminated and the generator start system will shut down. If the generator dies after successfully running for 5 minutes, the start attempt counter will be reset to zero and the inverter will only restart the generator if the auto start voltage setting or load amps AC setting is reached for the required time delay period.

To clear a generator start error, move the cursor from **AUTO** or **ON** to **OFF** in the **SET GENERATOR** menu item. This clears all the generator error conditions and resets the start attempts counter. You can access the **SET GENERATOR** menu item by pressing the green **GEN MENU** button.

The red **ERROR** LED indicator on the SWRC will **blink slowly** if one of the following generator errors occurs:

**GEN SPEED ERROR:** Indicates that the generator has synchronized but the frequency is not well adjusted (63 - 67 on the high-end or 53 - 57 on the low end).

**GEN FAILED TO START:** Indicates that five 'Generator Start Attempts' have occurred without successfully starting the generator, which could be caused by 1) Voltage has not reached 80 VAC during the '**MAX CRANK PERIOD**' or 2) Voltage does not maintain > 80 VAC for the majority of the time during the 'Generator Sync Period'.

**GEN STOPPED DUE TO V/F:** Indicates that the generator was running but was not operating within the voltage and frequency tolerances and not able to connect (out of sync), or the unit can not maintain synchronization (AC voltage or frequency is out of tolerance).

**GEN MAX RUN TIME ERROR:** Indicates that the generator ran for a period of time that exceeded the **SET MAX RUN TIME**, (this is an advisory error only and will not cause any other effect). This setting is used to determine if the generator is running longer than a calculated run time (i.e. total loads, battery state of charge...). To reduce the potential for causing future error indications, increase the **SET MAXIMUM RUN TIME** menu item setting under the **GEN AUTO START SETUP (12)** menu heading in the **SETUP** menu.

# OPERATION

## UTILITY BACK-UP MODE

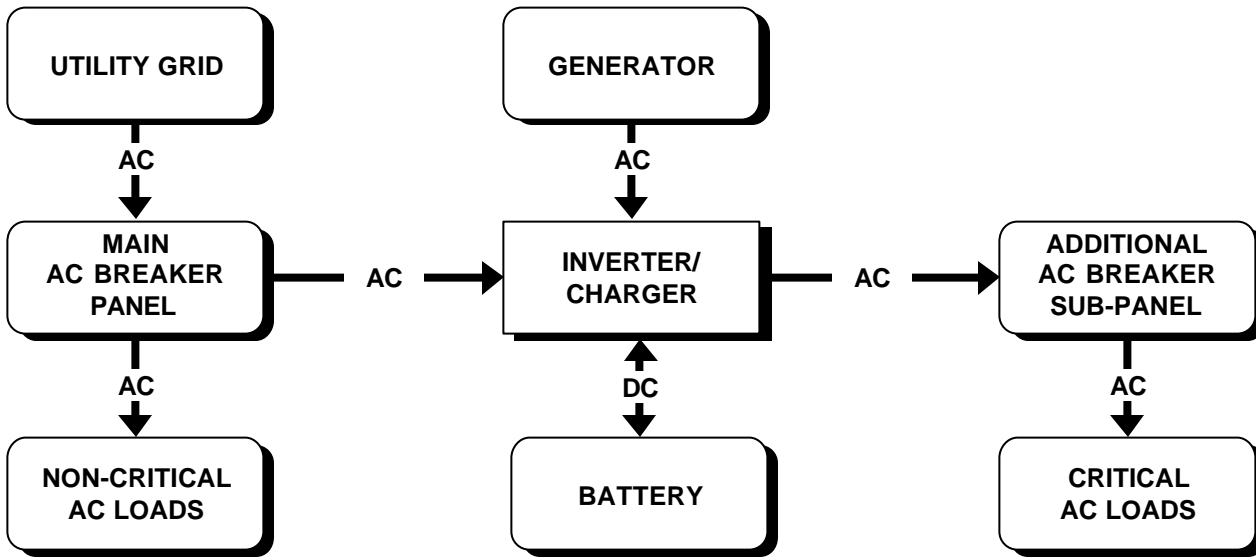

### IN BRIEF

PS Series Inverter/Chargers provide an excellent utility system backup under the majority of powering applications. Whenever a shorted grid condition affects voltage or frequency, the inverter disconnects itself from the grid and continues to support the AC load using battery power. Typical transfer time under a shorted grid condition is instantaneous.

Depending upon the type and amount of load, the transfer may, at times, be noticeable. This is due to the inverter's output reaching the overcurrent trip level as it tries to maintain the load before the internal relay transfers to battery power.

To operate the system in utility back-up mode, set-up the system as follows:

**NOTE: All adjustments require the SWRC.**

- Connect utility AC power to the inverter's **AC HOT IN** and **AC NEUTRAL IN** terminals.
- Connect AC loads to the inverter's **AC HOT OUT** and **AC NEUTRAL OUT** terminals.
- Set the '**MAXIMUM AC AMPS IN**' switch to the **AC1** position.
- Adjust the battery charger parameters if the factory default values are not satisfactory. For applications with small battery banks, lower the battery-charging rate.
- Adjust the **GRID (AC1) AMPS AC** menu item to match the amperage of the circuit breaker supplying AC to the inverter input. This setting is located in the **AC INPUTS (11)** menu heading - (See **UTILITY SUPPORT/OVERLOAD PROTECTION**, on page 81).

## UTILITY SUPPORT/OVERLOAD PROTECTION

This battery charger is very powerful and without limits could draw more current than is available from the AC input source. When the utility grid is available, the grid has to power both the battery charger and any AC loads connected. If AC charge current combined with any AC load current exceeds the **GRID (AC1) AMPS AC** menu item setting, the charge rate will be automatically reduced to keep from tripping the utility grid breaker.

In addition, the inverter will support the utility grid in the event that excessive loads threaten to trip the AC breaker. If the amount of power demanded by the AC loads is greater than the **GRID (AC1) AMPS AC** menu item setting, the inverter will contribute power to operate the AC loads. This will limit the AC current drawn from the utility system.

This ability allows the utility line to be sized closer to the typical draw of the system, instead of being sized to the maximum load. This may save considerable cost if a utility extension or upgrade is being installed. The savings can even offset part or all of the inverter/battery system in some situations.

While the inverter is supporting the AC loads, the battery will be discharging. Typically, utility line support is required for only short periods of time during heavy power usage that will not cause the battery to be significantly drained.

## USING SLT MODE (SILENT MODE)

In **SLT** mode the batteries are charged only once a day, at a time prescribed in the **BULK CHARGE TRIGGER TIMER (15)** menu heading. Selecting **SLT** in the **SET GRID USAGE** menu item, located under the **INVERTER SETUP (9)** menu heading enables it. During the rest of the day, the battery charger is turned off and the utility grid powers the AC loads. If a utility outage occurs, the inverter turns on and runs the loads. When power returns, the inverter will return to the **SLT** mode after it has completed the Bulk and Absorption stages of the battery charging process. The advantage of **SLT** mode is silent operation and slightly less power consumption under most conditions and quieter operation since the battery charger is off most of the time. The disadvantage of **SLT** mode is the loss of the natural power conditioning ability of the inverter and the ability to “back off” the AC input which prevents overloading or circuit breaker tripping (except during the time that the inverter is charging). The transition from utility to inverter when an outage occurs may also be more noticeable.

When using this mode, a **START BULK TIME** must be entered from the **BULK CHARGE TRIGGER TIMER (15)** menu heading. If the timer is defeated by setting it to 00:00, no bulk charging will take place on a daily basis except immediately after a grid failure has occurred and the power has been restored. The default setting is 00:00 that defeats the **BULK CHARGE TRIGGER TIMER**.

## BATTERY REQUIREMENTS

Utility back-up applications usually are designed to discharge the battery at a higher rate for a shorter duration than alternative energy applications. Typically, batteries capacity ratings are for discharge periods of 20 hours. This means that a 100-amp hour battery can deliver 5 amps for 20 hours. It cannot deliver 100 amp hours for 1 hour. Battery manufactures can provide de-rating curves for their products. If the battery is not large enough, unsatisfactory performance may result. For the best performance, oversizing of the battery is strongly recommended.

# OPERATION

## UTILITY INTER-ACTIVE MODE

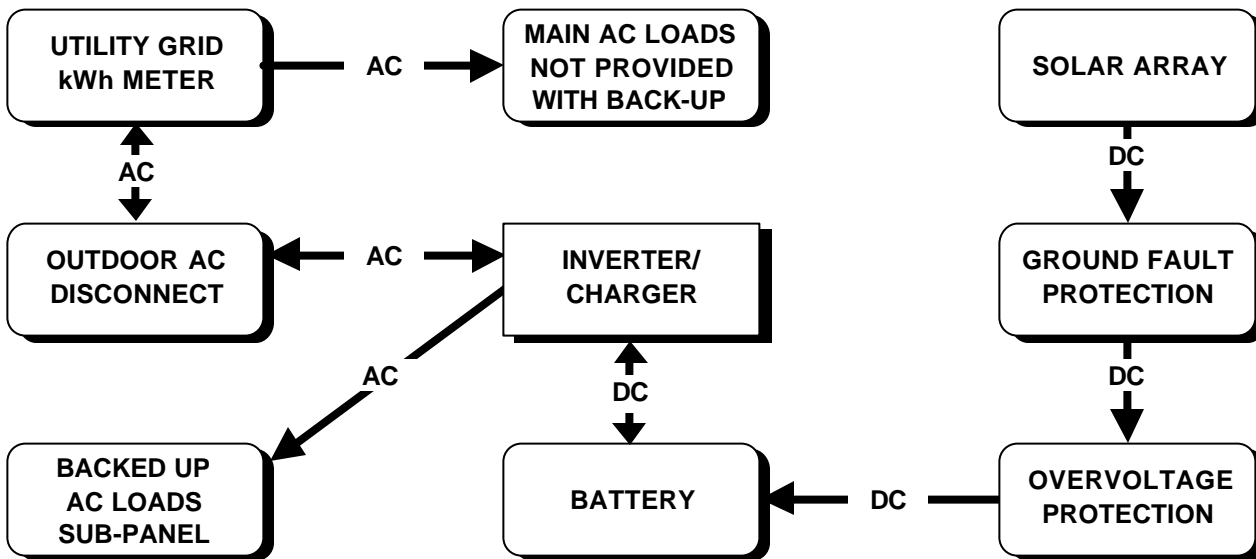

### IN BRIEF

In this mode, PS Series Inverter/Chargers can be used to move power from the DC system into the AC utility grid. This is often called “selling” power since the utility pays for the power you produce. It is relatively simple to set the inverter up to accomplish this. However, this type of installation is so new that many utility companies have not formalized their regulations regarding acceptable installations. Regulations will vary from one utility to another. The utility companies have a right and a need to be careful about how power is fed into their system. **Utility inter-active should be done with the assistance of your dealer and must be done with the approval of the local utility company.**

As a minimum, an outdoor mounted AC disconnect should be installed at the service entrance or next to the utility meter. It should be clearly labeled “**SOLAR ELECTRIC SYSTEM AC DISCONNECT**”. This will allow utility and emergency personnel to easily and safely isolate the system from the utility grid if required. This disconnect should be lockable (by the utility) and installed between the **AC HOT 1 INPUT** of the inverter and the circuit breaker in the AC load center connected to the utility grid. This allows the utility to shut off the system if a problem occurs.

Since a utility inter-active installation requires an understanding of your local utility code, limited diagrams and details are included in this manual. Consult your utility or your local Trace dealer.

To operate the system in utility inter-active mode, set-up the system as follows:

#### NOTE: All adjustments require the SWRC.

- Connect utility AC power to the inverter's **AC HOT IN** and **AC NEUTRAL IN** terminals.
- Connect AC loads to the inverter's **AC HOT OUT** and **AC NEUTRAL OUT** terminals.
- Set the ‘**MAXIMUM AC AMPS IN**’ switch to the **AC1** position.
- Use the **GRID USAGE TIMER (18)** and the **BULK CHARGE TRIGGER TIMER (15)** with the battery charger parameters adjusted under the **BATTERY CHARGING (10)** menu heading to determine the battery voltage level you require for your batteries.
- Select **SELL** from the **SET GRID USAGE** menu item in the **INVERTER SETUP (9)** menu heading.
- Adjust the **GRID (AC1) AMPS AC** menu item located in the **AC INPUTS (11)** menu heading (See **UTILITY SUPPORT/OVERLOAD PROTECTION**, on page 81) to match the amperage of the circuit breaker supplying AC to the inverter input.
- Adjust the AC input voltage parameters using the **SET INPUT LOWER LIMIT VAC** and the **SET INPUT UPPER LIMIT VAC** menu items, both located in the **AC INPUTS (11)** menu heading to match the AC voltage requirements of your connected utility.

## THEORY OF OPERATION

When **SELL** mode is selected from the **SET GRID USAGE** menu item located under the **INVERTER SETUP (9)** menu heading in the **SETUP MENU**, the inverter will move any excess power not required to charge the batteries into the utility grid.

In **SELL** mode, the inverter can be thought of as a battery charger that is able to operate in either direction - it can send excess power from the battery back into the utility grid instead of drawing power from the utility to charge the battery. To regulate the battery charging process, the inverter takes DC power from the solar array and converts it to AC power that it supplies to other AC loads through the utility grid. The inverter is more accurately described as a utility inter-active battery charger. This means that the inverter will control battery voltage whenever utility power is connected and available. If a utility outage occurs, the inverter can not control the battery voltage. Some external control must be provided by the system to prevent damaging the battery as the solar array tries to overcharge the battery.

In a solar array configuration, a charge controller is not needed when the inverter is operational and utility is connected. If the inverter was turned off, or utility power was to fail, the batteries could quickly be overcharged. One of the inverter's voltage controlled relays could be used to protect the batteries in case of utility failure. It would be programmed to open an additional external relay that controls the solar panels at a battery voltage above the battery charger's **BULK VOLTS DC** setting. Please see the **OVERVOLTAGE PROTECTION FOR THE BATTERY** section on page 88 for more information.

## UTILITY INTER-ACTIVE ISLANDING PROTECTION

In utility inter-active mode, the inverter is capable of detecting several types of failures.

- **Grid shorted** - Normally, when the utility power fails, the inverter momentarily tries to power the entire neighborhood. This condition looks like a short circuit to the inverter and causes it to reach the overcurrent protection setting and shuts off. It then opens its internal relay and disconnects from the utility grid. This protective system operates instantly.
- **Grid open** - The inverter can tell when there is no current being delivered to the grid and it will disconnect. This is used when a disconnect switch is opened or the power line which feeds the installation is cut. This protective system operates instantly.
- **Islanding** - This occurs when the grid has failed and the "neighborhood" that the inverter is powering requires a power level that the inverter can supply. This condition is called "islanding". The islanding detection circuit checks grid condition on each cycle. The inverter watches the utility grid and waits for it to rise a couple of volts before it begins to invert again. This is done on each cycle when **SELL** mode is activated. Typically, disconnect is achieved in a few cycles after the utility has failed. If a large electric motor is connected, it may provide enough generator capacity that the inverter thinks the grid is still connected. This can fool this protective system. Two additional protective systems are provided to then handle this condition, over / under frequency and over / under voltage detection.
- **Over/Under Frequency** - Since the inverter is locked onto the frequency of the utility grid, the frequency of the islanding system will drift out of regulation in a short amount of time during an islanding condition. This protective system may require a couple of seconds to respond. The settings are 58 and 62 Hertz for 60 Hertz models (48 and 52 Hertz for 50-Hertz models) and are not adjustable.
- **Over/Under Voltage** - Since the inverter does not try to regulate the voltage of the utility grid while selling power into it, the AC voltage will drift out of regulation in a short amount of time during an islanding condition. This protective system may require a couple of seconds to respond. The default settings are 108 VAC as the lower limit and 132 VAC as the upper limit. These settings are adjustable.

# OPERATION

## SELLING POWER - FROM A DC CHARGING SOURCE

The simplest and default operation of the PS Series Inverter/Charger in the **SELL** mode is to “sell” the excess power from the charging source to the utility when the batteries are full. In this mode, the battery voltage is held to the regulation level determined by the **SET BATTERY SELL VOLTS DC** setting. Since the **SET BATTERY SELL VOLTS DC** setting is defaulted to the same value as the **SET FLOAT VOLTS DC** setting, the inverter will sell the power from the charging source (wind, hydro or solar, etc.), but will hold the battery at a charged level.

The regulation process can also be accomplished and allow the three stage charging (float, bulk and absorption) of the batteries to occur each day by enabling the **BULK CHARGE TRIGGER TIMER (15)**. The batteries will be maintained at the **SET FLOAT VOLTS DC** setting until the **SET START BULK TIME**, which will charge the batteries near the **SET BULK VOLTS DC** setting until the end of the **ABSORPTION TIME**.

This operating mode offers the individual system owner with several advantages. The batteries would not be cycled thereby increasing their life and the batteries would be fully charged in case of a power failure, resulting in greater system efficiency.

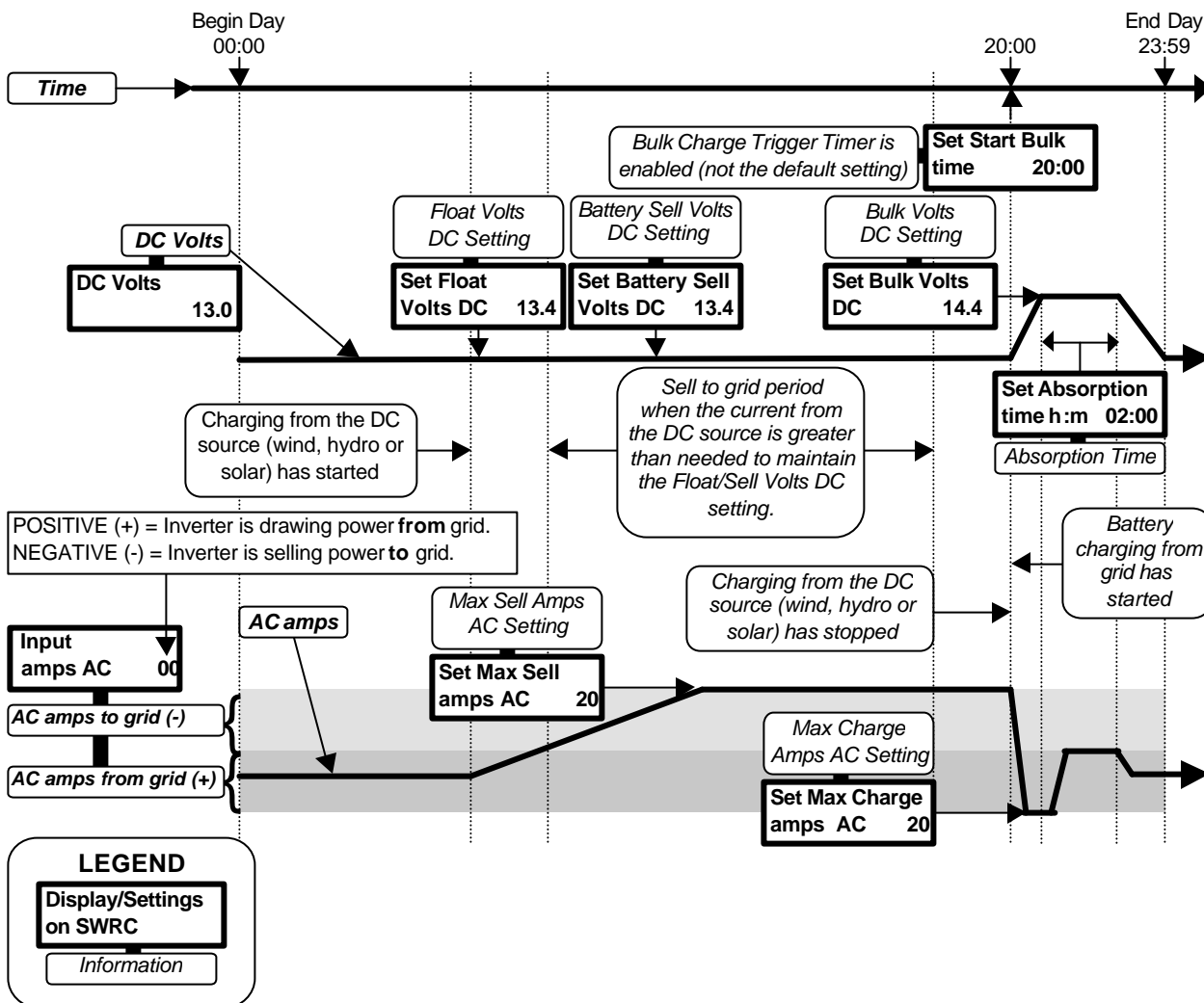

Figure 26, Selling Power from a DC Charging Source; Hypothetical Time of Day Operational History

**SELLING POWER - STORED IN THE BATTERIES**

Power stored in the batteries can also be sold into the utility grid. This can be used together with the solar array or alone without a solar array. The inverter can be programmed to sell the energy in the batteries at a specific time and then to recharge the batteries at another time. Both the discharge level and discharge rate can be adjusted to control the battery selling process.

Selling the power stored in the batteries can be used to level the output of the combined solar array and battery system. This is beneficial during conditions of cloudy weather when the solar array output will vary with each cloud that passes over. To set-up this ability, adjust the **SET BATTERY SELL VOLTS DC** menu item under the **BATTERY SELLING (17)** menu heading for the maximum discharge voltage level acceptable. The **SET MAX SELL AMPS AC** menu item should be set for the expected maximum output of the solar array. Next, access the **GRID USAGE TIMER (18)** menu heading to allow setting of the time period that the battery will be allowed to recharge during by adjusting the **SET START CHARGE TIME** and **SET END CHARGE TIME** menu items. Outside of this time period, the inverter will sell the power stored in the battery to the utility grid until the voltage reaches the **BATTERY SELL VOLTS DC** setting.

This mode can use the battery to maximize the output of the system during a specific period of time. An example of these setting follows:

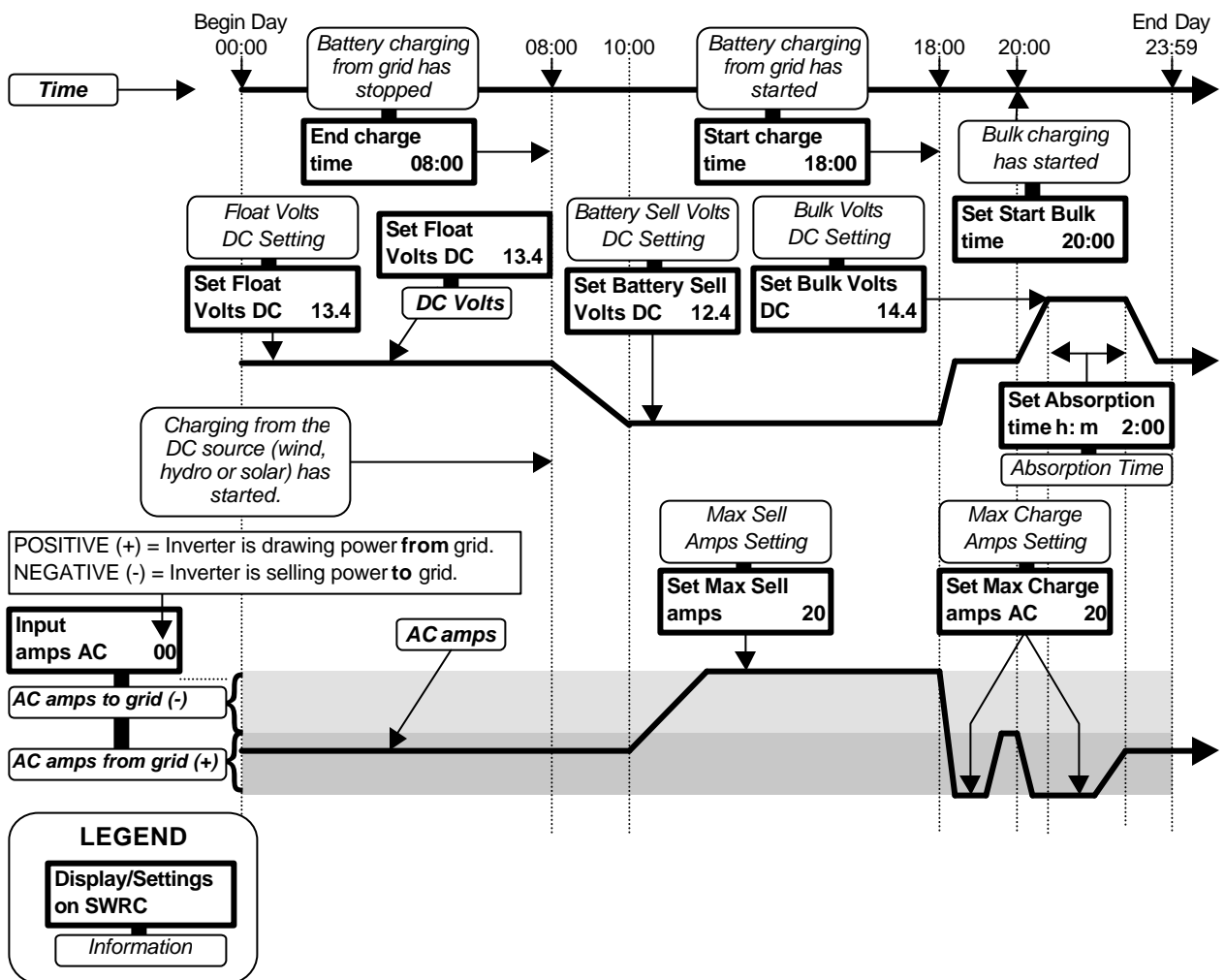

Figure 27, Selling Power Stored in the Batteries; Hypothetical Time of Day Operational History

# OPERATION

---

A system that includes 2400 watts of solar array is able to produce approximately 18 amps of AC power at 120 VAC. The output is most needed from 12:00 noon to 18:00 by the utility. If the **GRID USAGE TIMER** is set to a **START CHARGE TIME** of 18:00 and a **END CHARGE TIME** of 12:00 noon, the inverter will sell the battery from 12:00 noon to 18:00. The energy in the batteries will be used only if the solar array is not able to provide enough power to reach the 18 amps AC (determined by the **MAX SELL AMPS AC** setting under the **BATTERY SELLING (17)** menu heading. The battery will assist the solar array to meet the 18 amps AC **MAX SELL AMPS AC** setting during the battery sell period. If the battery reaches the **SELL VOLTS DC** setting during the sell period, the AC output current will slowly taper down to the solar array's output level and the battery will not be further discharged. At 18:00, the battery will charge at the rate allowed by the **SET MAX CHARGE AMPS AC** (2 amps AC is the lowest setting allowed). The battery will be recharged only to the **FLOAT VOLTS DC** setting unless the **BULK CHARGE TRIGGER TIMER (15)** menu heading is used to trigger a bulk charge cycle.

This system offers the utility several advantages. The system can be relied on for a specific amount of output at a set time. The AC output of the system from 12 noon to 4 PM will not vary with the level of sunlight (after all, the AC loads on the grid do not suddenly drop when a cloud passes over). Only if it is extremely cloudy will the system not produce its rated output for the full time period - which would not be as important since the ambient temperature would not be as high.

This operating mode does not provide an individual system owner with many added values. The wear and tear on the batteries would be avoided and greater efficiency achieved if the standard sell mode was used.

## SELL MODE

### GRID USAGE TIMER

- With the **GRID USAGE TIMER** enabled (the **START CHARGE TIME** beginning time is not equal to the **END CHARGE TIME**), the inverter will charge the battery to the **FLOAT VOLTS DC** setting at the **START CHARGE TIME**. After the **END CHARGE TIME**, the inverter turns off the battery charger and begins to "sell" power into the utility grid from the battery (or any other DC sources available and connected to the batteries) to the **SELL VOLTS DC** setting. The current will be limited to a maximum level controlled by the **MAX SELL AMPS AC** menu item setting under the **BATTERY SELLING (17)** menu heading.
- With the **GRID USAGE TIMER** disabled (the **START CHARGE TIME** beginning time is equal to the **END CHARGE TIME**), the inverter will use the utility grid (or any other DC sources available and connected to the batteries) to maintain the batteries to the **FLOAT VOLTS DC** setting.

In the **SELL** mode, the battery voltage will be held near the **BULK VOLTS DC** setting for the adjustable **ABSORPTION TIME** period setting after an AC failure or upon encountering a **BULK CHARGE TRIGGER TIMER** event.

### LED INDICATORS (ON THE SWRC)

- The **LINE TIE** LED will be on (solid) when the **SELL** mode is enabled.
- The **FLOAT** LED will be on (solid) when the **SELL** mode is enabled and the inverter is maintaining the batteries to the **FLOAT VOLTS DC** setting.
- The **FLOAT** LED will blink when the **SELL** mode is enabled and the inverter is maintaining the batteries to the **SELL VOLTS DC** setting.
- The **BULK** LED will be on (solid) when the **SELL** mode is enabled and the inverter is maintaining the batteries near the **BULK VOLTS DC** setting.



**UTILITY INTER-ACTIVE OPERATION WITH UTILITY BACK-UP**

The PS Series Inverter/Charger is capable of operating both as a utility inter-active and a stand-alone inverter. This allows the system to normally sell the excess power to the utility and, once an outage has occurred, provide power to the AC loads from the battery.

The loads that will be provided with utility back up during outages must be isolated from the non-utility backed-up loads. This usually requires the addition of an AC load center sub panel for the output of the inverter.

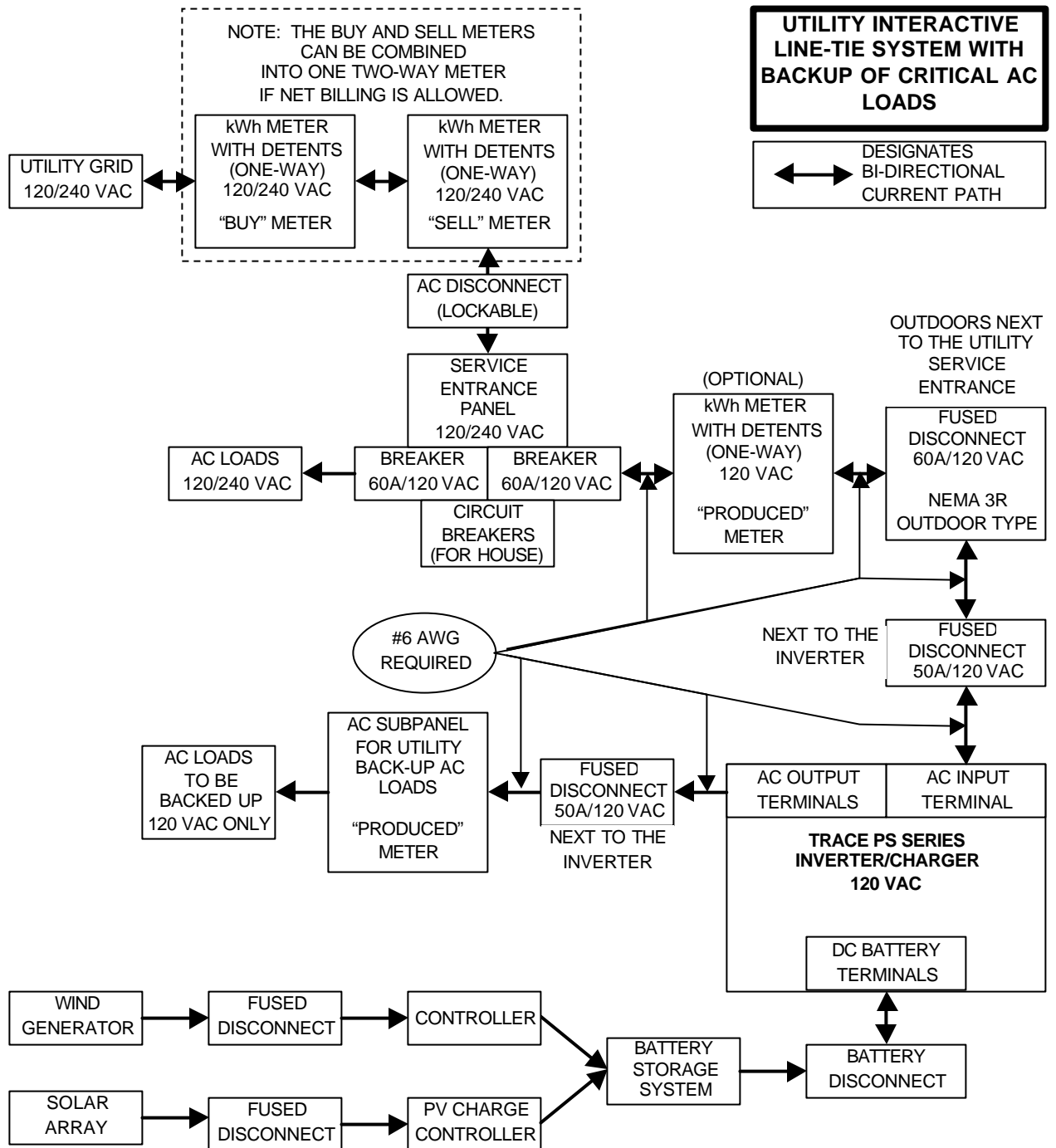

Figure 28, Utility Interactive Line-Tie System with Battery Backup (120VAC models)

# OPERATION

## OVERVOLTAGE PROTECTION FOR THE BATTERY IN SELL MODE

Normally, the inverter will regulate the charging process of the battery by selling excess power into the utility grid. The battery will receive a three-stage charge routine as previously described. If the utility grid is not available (due to an outage or tripped AC input circuit breaker, etc.) or if the inverter shuts off, then the inverter is not able to sell the excess power and the battery voltage will not be regulated, resulting in possible overcharging of the battery.

Therefore, a separate control is required to provide overvoltage protection for the battery when an outage has occurred. The PS Series Inverter/Charger with the optional **AUX RELAY MODULE** is designed to control an externally connected power relay that would disconnect the solar array and stop the charging process. The voltage and hysteresis (difference between opening and closing voltage) are both adjustable. The external relay can be either a standard mechanical type or a mercury displacement type, depending on the voltage and current required. The mercury displacement type relay is usually required when the system voltage is 48 VDC or if the current of the solar array exceeds about 20 amps. Multiple relays can be used if the solar array is divided into several source circuits (do not parallel relays for higher current). Another option is to use a charge controller such as the Trace C40. For more on the **AUX RELAY MODULE**, see page 128.

A typically wiring configuration for this overvoltage protection is as follows:

This circuit does draw a small amount of power all of the time to power the coil of the relay. Other circuits are possible but may have other drawbacks. This circuit provides protection against overcharging the batteries.

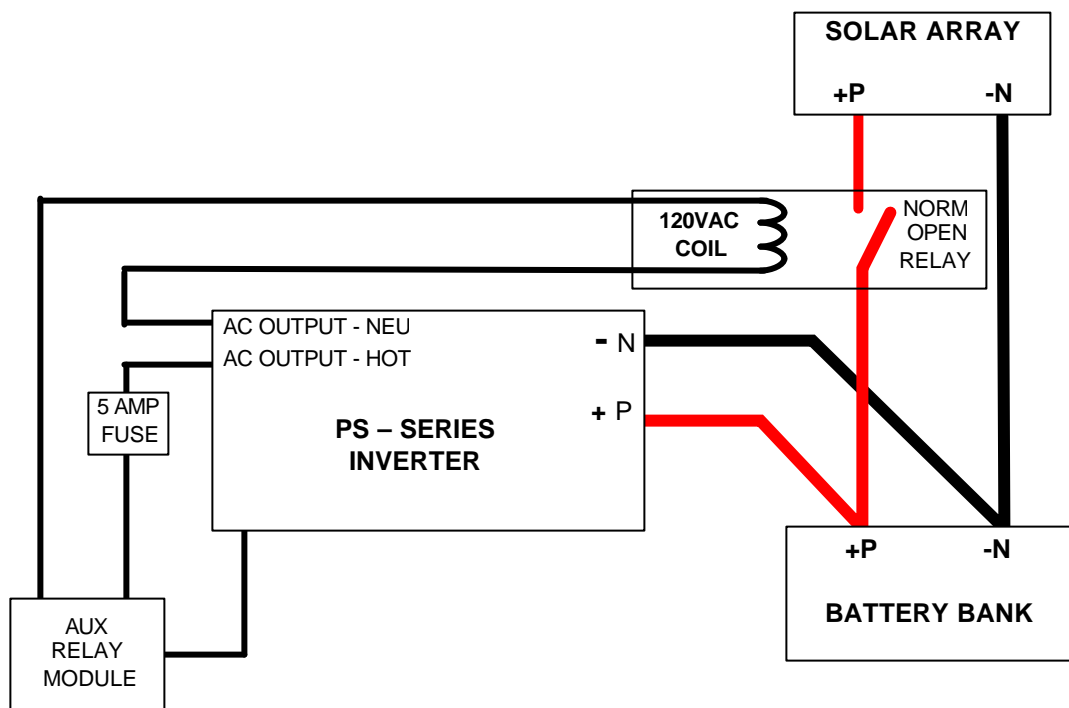

Figure 29, Overvoltage Protection for Battery

## ENERGY MANAGEMENT MODES

The purpose of these modes is to manage how utility power is used. There are three possible ways this can be accomplished. **TIME OF DAY METERING MODE** is used to shift the time at which utility power is used -charge the batteries at a favorable time and then use the power later, **PEAK LOAD SHAVING MODE** is to limit the maximum draw the AC loads place on the utility and **LOW BATTERY TRANSFER MODE** allows you to operate your loads from an alternative power source and use the utility as a back-up source.

To operate the system in any of the Energy Management Modes, set up the system as follows:

**Note:** All adjustments require the SWRC.

- Connect utility AC power to the inverter's **AC HOT IN** and **AC NEUTRAL IN** terminals.
- Connect AC loads to the inverter's **AC HOT OUT** and **AC NEUTRAL OUT** terminals.
- Set the '**MAXIMUM AC AMPS IN**' switch to the **AC1** position.
- Adjust the **GRID (AC1) AMPS AC** menu item to match the amperage of the circuit breaker supplying AC to the inverter input. This setting is located in the **AC INPUTS (11)** menu heading – (See **UTILITY SUPPORT/OVERLOAD PROTECTION** on page 81).

### TIME OF DAY METERING MODE

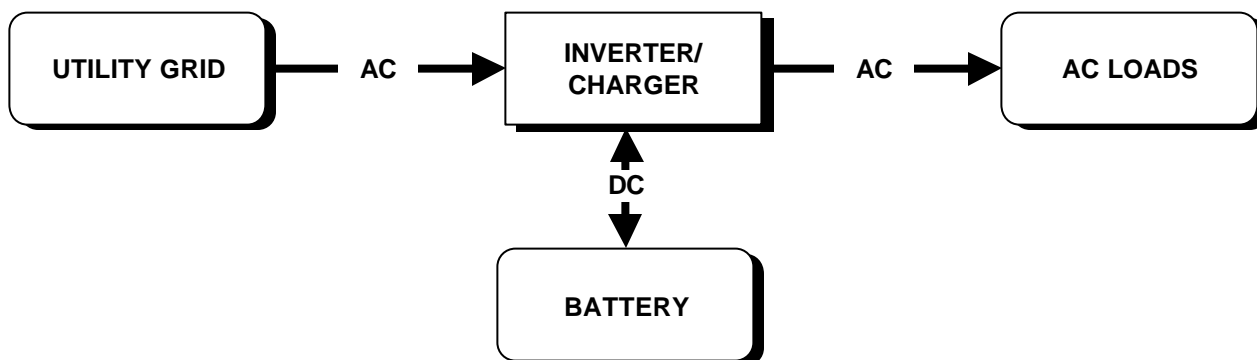

This mode is often desirable when time of day metering is available. An external source of power (wind, hydro or wind) is not required, but can be used to reduce the discharging of the battery. Since the most expensive power is often during the afternoon, the solar array may be a valuable addition. This mode is an alternative to utility inter-active systems. This mode does not involve “selling” power into the utility grid and therefore does not usually require the approval of the utility. The same system is also able to operate as a utility back-up system to provide power when an outage occurs.

In order to disconnect from grid during a specific period of the day and operate only as an inverter, a window of time is created in which battery charging is allowed. Outside of this window, the inverter will power the load from the battery. If the battery gets low, the system will transfer back to the utility and prevent the battery from discharging.

The following additional settings allow for this mode of operation:

- **SET GRID USAGE MODE** menu item is set to **FLT**. This is located under the **INVERTER SETUP (9)** menu heading in the **SETUP** menu.
- **SET START CHARGE TIME** menu item under the **GRID USAGE TIMER (18)** menu heading is set to the time the inverter connects to the utility. This is the beginning of the time the battery charger is allowed to operate and the end of the inverter operating period.

# OPERATION

---

- **SET END CHARGE TIME** menu item under the **GRID USAGE TIMER (18)** menu heading is set to the time that the inverter disconnects from grid and begins to run the loads from the battery. At this time, the battery charger will stop charging. If the battery voltage falls to the **LOW BATTERY CUT OUT VDC** menu item setting during the inverter operating time period, the AC loads will be reconnected to the utility grid. This prevents over-discharging the battery. The battery will be charged when the next **START CHARGE TIME** is reached.
- Set the **START BULK TIME** menu item under the **BULK CHARGE TRIGGER TIMER (15)** menu heading to a time after the **START CHARGE TIME** menu item setting. This allows delaying of the bulk charge cycle to a later time. Before the bulk charge is started, the battery will be charged only to the float voltage level. The **START BULK TIME** is usually set to occur during the lowest cost rate period. Adjusting the **SET FLOAT VOLTS DC** menu item to just above the normal at rest voltage (12.6 VDC) will reduce the amount of charging that occurs in the between time periods, yet will allow limited charging to prevent sulfation of the battery while being partially discharged.

The system should be designed so that the battery is able to operate the loads for the entire peak rate period without reaching the **LOW BATTERY CUT OUT** voltage. This may require that heavy loads be operated only during the non-peak rate period.

This mode may be advantageous when a utility offers time-of-day metering that allows you to buy power at a variable rate during different time periods. For example, the rate may only \$0.04 per kilowatt from midnight to 6 AM, but \$0.16 during the peak period from noon to 6 PM. The in-between period might cost \$0.08 per kilowatt. The idea is to not use power during the peak period and to charge the batteries at night. A solar array is not required, but since it produces the most power during the peak period, it will reduce the amount of power required from the battery.

To program the inverter for this example, adjust the **START CHARGE TIME** menu item to 6 PM (18:00 hours) and the **SET END CHARGE TIME** menu item to NOON (12:00 hours). The **SET START BULK TIME** menu item under the **BULK CHARGE TRIGGER TIMER (18)** menu heading would be set for after midnight (00:30) to delay most of the recharging until the cheapest period. Adjusting the **SET FLOAT VOLTS DC** menu item setting to the nominal full battery voltage level (12.6 VDC) will reduce the amount of charging that occurs in the between time periods, yet will allow limited charging to prevent sulfation of the battery while setting partially discharged.

If the battery is full and power is available from the solar array, it will be used to directly power the AC loads connected to the inverter output although the utility grid is also connected to the loads. If the amount of power exceeds the AC loads connected, the battery voltage will increase. An external solar array controller is required to limit the battery voltage to a safe level and to prevent overcharging and possible damage to the battery when only light AC loads are being powered.

Note: The round-trip net energy efficiency of charging and discharging a Deep Cycle battery rarely exceeds 50%. In order for this technique to be cost effective, the off-peak rate for electricity should be at least half of the on-peak rate. The cost of battery replacement should also be calculated and included when evaluating this technique.

## PEAK LOAD SHAVING MODE

### IN BRIEF

Another way the inverter can be used as an energy management tool is to limit the maximum draw the AC loads place on the utility grid. Many utilities impose a surcharge on their customers based on the peak load used by a facility. The PS Series Inverter/Charger can be configured to provide all of the power above a specified level, eliminating the surcharges. With the SWRC, simply adjust the **SET GRID (AC1) AMPS AC** menu item to the maximum value allowed by the utility without the peak load surcharge. All AC loads must be connected to the output of the inverter through the 50-amp AC transfer relay located internally. Multiple inverters may be required for larger applications with individual groups of loads connected to each inverter. This can be used in addition to time of day metering and still allows the inverter to provide a utility back-up function in addition.

## LOW BATTERY TRANSFER (LBX) MODE

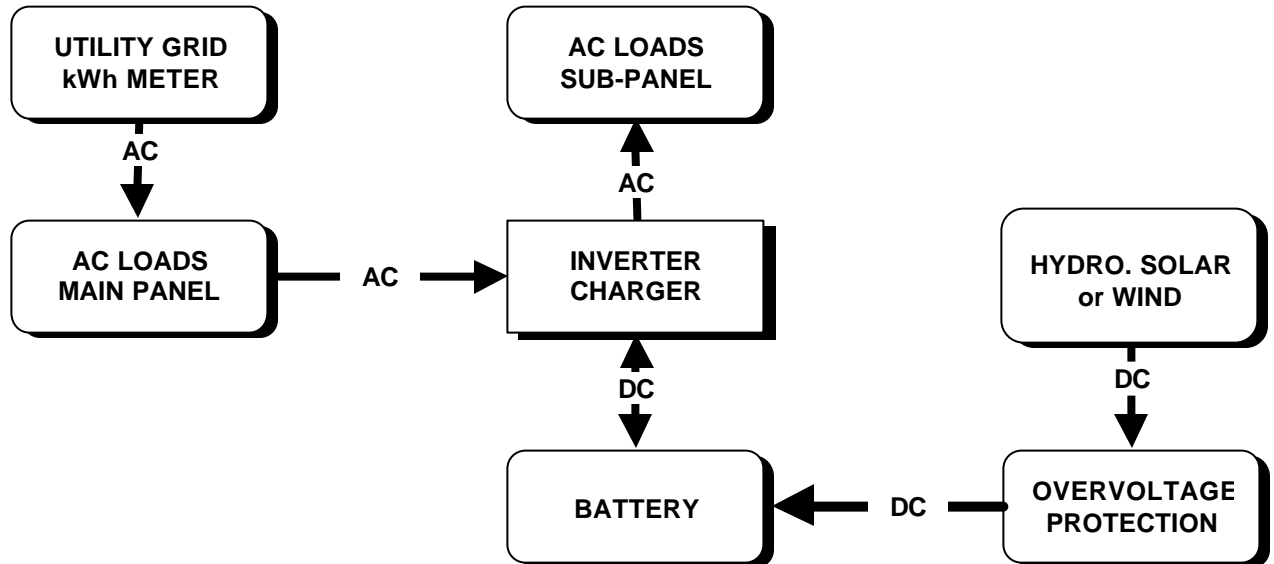

This mode is used as an alternative to the **TIME OF DAY METERING MODE** or as a way of operating “off the grid” with the utility as a back up. The system requires an external source of power (wind, hydro, or wind) to operate as a stand-alone power system, independent of the utility grid. Since power is never sold back to the utility, this configuration does not require utility approval.

In order to disconnect from grid during a specific period of the day and operate only as an inverter, a window of time is created in which battery charging is allowed. Outside of this window, the inverter will power the load from the battery. If the battery gets low, the system will transfer back to the utility and prevent the battery from discharging.

The following additional settings allow for this mode of operation:

- **SET GRID USAGE MODE** menu item is set to **LBX**. This is located under the **INVERTER SETUP (9)** menu heading in the **SETUP** menu.

The system should be designed so that the battery is able to operate the loads without reaching the **LOW BATTERY TRANSFER VDC** setting. If the system is not able to keep up with the power requirements of the AC loads, the battery will discharge. When the battery voltage reaches the **LOW BATTERY TRANSFER VDC** menu item setting, the inverter connects the AC loads to the utility grid. When the DC charging source (Solar, Hydro or Wind) is allowed to charge the batteries (no battery charging will occur from the utility) and the battery voltage reaches the **LOW BATTERY CUT IN VDC** menu item setting, the inverter disconnects from the utility grid and again operates the AC loads from the batteries.

Once the system has transferred back to the battery, the battery voltage will continue to increase if the power from the alternative source exceeds the loads. This can result in the battery voltage reaching the **HIGH BATTERY CUT OUT VDC** setting unless a charge control device limits the battery voltage. Note that the **LOW BATTERY CUT IN VDC** setting must be set below the external charge controllers regulation setting or the system would never transfer back to the battery.

The **LOW BATTERY TRANSFER VDC** setting must always be set higher than the **LOW BATTERY CUT OUT VDC** setting. If utility back-up operation is expected, keep the **LOW BATTERY TRANSFER VDC** setting high to prevent excessive discharging of the battery. It should not be set to a level that is higher than the normal at rest battery voltage level or the system will transfer whenever no alternative power source is available (such as each night with solar). If the utility power is not available, the inverter will operate the AC loads until the battery voltage reaches the **LOW BATTERY CUT OUT VDC** setting. It will then shut off and only reset if the battery voltage reaches the **LOW BATTERY CUT IN VDC** level or the utility power becomes available again.

# OPERATION

---

## USING MULTIPLE INVERTERS

Multiple PS Series Inverter/Chargers can be used in the same system. There are some limitations to the design of the system for successful and reliable operation. The inverters can be used in a "series" configuration to operate 240 VAC loads and to connect to 120/240 VAC power systems.

Two inverters can also be connected together and operated in parallel to provide twice the power at the same output AC voltage. The inverters can operate in parallel as battery chargers from the same AC source connected to the same battery. The AC input terminals and DC terminals would then be all in parallel. The inverters will synchronize individually to the AC source and then connect.

### "SERIES" STACKED OPERATION

As mentioned, two inverters can be connected in a "series" stacked configuration to provide 120 and 240 VAC output.

When series stacked, you get twice the power of a single inverter available for operating 240 VAC loads, but only one inverter's power is available for operating a single large 120 VAC load. Separate 120 VAC loads can be operated from either inverter. Do not connect the AC output terminals of the inverters in parallel - this will not work. A special stacking interface cable (**SWI**) is required to connect the series stacking ports of the inverter to ensure the output voltage waveforms of the two inverters are phase synchronized and locked 180 degrees from each other. This allows connection to 120/240 VAC generators and utility grids. The 120 VAC loads are split and connected to either inverter. Both of the inverters operate completely independently - except for their frequency is locked. They do not operate as a master-slave device as previous inverters have. One inverter can be in battery charger mode while the other is inverting to power an AC load. This independent operation allows many new possible applications and abilities that were previously not possible when inverters were paralleled stacked.

When inverters are series stacked, they do coordinate all operations that affect 240 VAC loads. This requires that the inverters turn on together and switch to another AC source at the same time. If either inverter shuts down, both inverters are turned off at the same time.

If no 240 VAC loads are required to be operated, then the need and benefits of stacking are reduced. Stacking adds complexity and will cause both of the inverters to shut down if either inverter goes into an error condition. With separate (un-stacked) inverters, only one will shut down if over-loaded, etc.

When two inverters are connected to a 120/240 VAC distribution system **without** using the stacking interface cable, the AC neutral wiring must be capable of handling **twice** the inverter output. This is due to the lack of synchronization between the inverters. If both inverters are operating in exact synchronization (as opposed to operating 180 degrees out of synch.), then the AC neutral will carry the current of both inverters, which was split among the two AC hot conductors. This often is not a problem since the AC distribution system may be oversized to handle the higher output level of a generator. When an AC source is connected to the inverters, the inverters will synchronize independently and transfer at different times. This is not a problem if no 240 VAC loads are connected to the output of the system.

**Caution:** You must connect the two chassis of the inverters together and to the grounding system by their grounding lugs or a hazardous voltage may be present on the chassis of the inverters. This is caused by an internal filter circuit on the output of the inverter and is normal.

### INPUT/OUTPUT BYPASS BREAKER SWITCH – 240 VAC LOADS

An inverter "bypass-breaker switch" diverts power around an inverter and is meant to be used only during times of maintenance or to remove the inverter out of the installation. There is a possibility with a multiple inverter installation stacked in "series" (120/240 VAC) with two bypass switches installed, that one inverter bypass breaker switch could be in the *Bypass Operation* position (power diverted around the inverter's) and the other inverter bypass breaker switch could be in the *Normal Operation* position (power passing thru the inverter). The resulting output of the two bypass switches may be less than 240 VAC, which could cause problems with any 240 VAC loads that are not protected against an AC phase shift.

## 240 VAC/60 HZ ONLY ELECTRICAL SYSTEMS

Two 120 VAC / 60 HZ inverters “series” stacked can be used to provide 240 VAC. This provides both 120 and 240 VAC since a center “neutral” is provided between the two inverters. If a 240 VAC only AC source is connected to the AC input terminals of the inverter without this center neutral, unacceptable operation will result. To allow connection of a 240 VAC only source to 120 VAC inverter's, a small (2000 VA) auto-transformer must be connected across the 240 VAC source with the center of the transformer connected to the AC neutral terminals of the inverters. This will allow the inverter to operate properly. No transformer is required on the AC output side - the 240 VAC can be taken directly from the two AC hot output terminals (one from each inverter).

## “PARALLEL” STACKED OPERATION

The parallel stacking interface allows twice the continuous and surge capacity to be available on a single output circuit from two inverters. The pass-through capacity is also doubled when connected to an AC source such as a fuel-powered generator or a utility grid. The inverters operate in parallel and split the loads between them. The inverters must be identical models and must have software revision REV 4.3 or higher software. The inverters must be connected to the same battery bank with equivalent cabling (both in length and in cable size). The inverter DC negative terminals of the inverters must be connected together either at the inverters or at a location close to the inverters (within 18 inches / 0.5 meters).

The parallel stacking interface cable (**SWI/PAR**) simply plugs into the stacking port on the left end of each inverter and allows the two inverters to operate as a single inverter. The interface method is based on the series stacking system offered for the PS Series inverters since their introduction for the North American market. The parallel stacking system operates the inverters in phase by having one of the inverters operate as the MASTER and the other as a SLAVE. When an AC source is connected, the MASTER first synchronizes to the AC source, then connects to it and battery charges. Since the SLAVE follows the master and is set-up with a longer warm-up delay, the SLAVE inverter is already synchronized when it transfers the loads and starts battery charging. This allows very smooth transitions from inverter mode to charger mode.

The parallel stacking interface system allows doubling of the AC pass through capacity. This is useful when large generators are used. Both inverters will battery charge as allowed by the settings in each of the inverters.

The hook-up depends upon the other components included in the system and whether it was ordered as only inverters, a power panel system, or a power module system. With the power module system, the paralleling enclosure is eliminated and all of the wiring is completed for you. With the individual inverters and the power panel system, the paralleling enclosure and parallel stacking interface cable must be installed on site. The paralleling enclosure is connected to each of the inverter's outputs and is also connected to the AC loads being powered.

At this time, the paralleled inverters are intended to operate as a single unit. In case of an inverter fault or error condition, both inverters turn off as one. When the error has been corrected, the inverter will automatically or manually reset depending upon the type of error condition.

If an inverter failure occurs, the parallel stacking interface can be manually bypassed and the parallel stacking interface cable can be removed to allow temporary operation on one unit.

## GENERATOR START SETTINGS

When using two units in parallel, it is recommended that only the SLAVE inverter be used to control the generator. This is required because the generator control system includes a cool down timer that causes the controlling inverter to disconnect from the generator before it turns the generator off. If the MASTER controls the generator, then the SLAVE may not stay in sync with the MASTER during the cool-down period since it will remain in sync with the generator and not follow the MASTER. There currently is no adjustment for the cool-down period, so restricting the generator control to the SLAVE is the only solution available at this time.

The SLAVE also must be set with a longer warm-up period than the MASTER in order to prevent them from trying to synchronize to the generator at the same time. When the MASTER synchronizes first, the SLAVE will automatically be synchronized after its warm-up period passes. This also makes the transfer from inverter to generator smoother and less noticeable.

# OPERATION

---

## BATTERY CHARGING WITH MULTIPLE INVERTERS

The inverters can operate in parallel as battery chargers from the same AC source connected to the same battery. The AC input terminals and DC terminals would all be in parallel. The inverters will synchronize individually to the AC source and then connect.

When multiple inverters are connected to the same battery and operated as in battery charger mode, the settings of the inverters are best set to the same settings. Only when a system is being operated in automatic generator start mode should staggered settings be used.

The most significant problem with multiple inverters charging the same battery is the voltage ripple caused on the battery. This causes the chargers to not reach their full output - two battery chargers on the same battery may not provide twice the charging rate to fill the battery in half the time. The higher the charger rate and/or the smaller the battery, the more pronounced this problem would be. The only way to reduce the problem is to individually cable each inverter and to connect them at opposite "corners" of the battery bank. Keeping the cable size as short as possible also helps.

Since the inverters will all be charging the same battery, one inverter may taper off first and finish the bulk stage before the other. When a single inverter has reached the float stage, it is best to turn off the generator at this time. It may take a longer period of time for the remaining inverters to reach the float stage. Running the generator to only power an inverter that is float charging is very inefficient and should be avoided.

If multiple Battery Temperature Sensors are installed, ensure they are all connected to the same location (battery). This will also help prevent one inverter from tapering off first.

## AUTOMATIC GENERATOR START WITH MULTIPLE INVERTERS

When using multiple inverter/chargers with the automatic start system, only one inverter/charger controls the generator. The two inverter/chargers should be programmed with the same **BULK VOLTS DC** and **FLOAT VOLTS DC** settings, but with the **ABSORPTION TIME** on the non-generator start inverter/charger to a longer setting. This will ensure that the charge current is shared between the two inverter/chargers more equally during the absorption stage by preventing one of the inverter/chargers from switching to float before the other. When the inverter/charger that controls the generator reaches float, it will shut down the generator.

The same consideration should be made if you are trying to equalize the batteries. The two inverter/chargers should be programmed with the same **EQUALIZE VOLTS DC** settings, but with the **EQUALIZE TIME** on the non-generator start inverter/charger to a longer setting.



---

**TECHNICAL INFORMATION****BATTERIES**

This section of the manual is included to help you better understand the factors involved with battery charging, care, and maintenance, by discussing the physical make-up and characteristics of chemical storage batteries. This is not intended to be an exhaustive discussion of battery types, but simply a guideline. The manufacturer of each specific battery is the best authority as to its use and care.

Batteries come in different sizes, types, amp hours, voltages and chemistries. There are nearly as many descriptions of exactly how batteries should be charged, as there are people willing to offer explanations. It is not possible here to discuss all aspects in detail. However, there are basic guidelines you can follow that will help in battery selection and ensure that the batteries are better maintained than the majority.

See the ***INVERTER/CHARGER TERMINOLOGY*** glossary on page 114 for a brief description of terms that appear in this section with which you may not be familiar.

**SELECTION OF BATTERY TYPE**

There are two principal types of batteries: starting and deep-cycle. There are several different types of battery chemistries including liquid lead-acid, nickel-iron (NiFe), nickel-cadmium (NiCad), alkaline, and gel-cell. Batteries are either sealed or non-sealed (vented).

**STARTING BATTERY**

These are designed for high cranking power, but not deep cycling. Don't use them. It does not hurt the inverter - they simply will not last long in a deep cycle application. The way they are rated should give a good indication of their intended use. - "Cold Cranking Amps", a measure of the amperage output that can be sustained for 30 seconds. Starting batteries use lots of thin plates to maximize the surface area of the battery. This allows very high starting current but lets the plates warp when the battery is cycled.

**TELEPHONE COMPANY BATTERY**

Second-hand telephone company batteries are often available at far below original cost. They are often used to power the telephone system for short power outages. They are sometimes used successfully in remote home systems. Typically, they are a lead calcium type battery, similar in construction to a starting battery. Therefore, they should not be repeatedly discharged more than 20% of their amp/hr rating. Keep this in mind when evaluating their amp/hr to cost ratio.

**DEEP CYCLE BATTERY**

This is the type of battery best suited for use with inverters. The physical dimension of the plates are thicker and the active material that holds the charge is more dense to increase cycle life. The "deep cycle" type of battery is designed to have the majority of their capacity used before being recharged. They are available in many sizes and in either "non-sealed" or "sealed" types.

**NON-SEALED LEAD ACID BATTERY**

The most common type of deep cycle battery is the non-sealed, liquid electrolyte battery. Non-sealed types have battery caps. The caps should be removed periodically to check the level of electrolyte. When a cell is low, distilled water should be added. The electrolyte level should be checked monthly and topped up if needed after recharging.

The most common "non-sealed" deep cycle battery is the type used with boats and motor homes. They typically are called "Group 27" batteries and are similar in size to a large truck battery. They are 12-volt batteries rated at 80 to 100 amp-hours. Often the deep cycle claim is over-stated. They do work better than a car battery, but are not recommended for anything but the smallest systems.

Another popular and inexpensive battery of this type is the "golf cart" battery. It is a 6-volt battery rated at 220 amp-hours. They can be cycled repeated to 80% of their capacity without being damaged. This is the minimum quality of battery that should be used with PS Series Inverter/Charger applications.

Many systems use the L16 type of battery. These are 6-volt batteries rated at 350 amp-hours and are available from a number of manufacturers. They are 17 inches in height and weigh up to 130 pounds each - which may be troublesome in some applications such as RV or marine installations.

# TECHNICAL INFORMATION

---

Type 8D batteries are available with either cranking or deep cycle construction. The deep cycle versions are 12-volt batteries rated at 200 amp hours or so. Since they are most commonly used to start truck engines, you should make sure you purchase the deep cycle version.

## SEALED LEAD ACID BATTERIES

**CAUTION: IF USING GELLED BATTERIES, THE BATTERY CHARGER MUST BE SET TO THE APPROPRIATE SETTINGS OR BATTERY DAMAGE WILL OCCUR.**

Another type of deep cycle battery construction is the sealed "valve regulated" lead acid battery. They are a rechargeable battery that recombines suppressed gases, thus eliminating the need to add water. Since they are tightly sealed, these batteries will not leak and can be installed in certain applications where 'liquid type' batteries could not be installed.

While there are many manufacturers of quality non-sealed batteries, there are only a few manufacturers of suitable sealed batteries. Don't confuse sealed batteries with "maintenance free" batteries - the later is typically a standard liquid electrolyte type battery without caps for adding water - when the electrolyte gets low you replace the battery.

The advantages of true "deep cycle" sealed batteries are no maintenance (does not require acid checks or periodic watering), long life (800 cycles claimed) and low self-discharge. The disadvantage is high initial cost and because water cannot be added, they are less tolerant of overcharging.

Two methods are used to seal batteries by a process of immobilizing the electrolyte, which in turn eliminates free-flowing acid. Both these battery types can be used in inverter applications.

### **GEL CELL**

Silica gel is added to the electrolyte, causing it to 'set' in gelatin form.

### **ABSORBED GLASS MAT (AGM)**

Highly absorbent glass mat separators are used between each plate to retain the liquid electrolyte.

Even with all the advantages of sealed batteries, there is still a place for the standard flooded deep cycle battery. Sealed batteries will cost 2 to 2.5 times as much as "liquid" or flooded batteries. In many installations, where the batteries are set in an area where you don't have to worry about fumes or leakage, a standard or industrial deep cycle is a better economic choice.

## **NICAD AND NICKEL IRON (NIFE) BATTERY**

Trace inverters and battery chargers are optimized for use with lead acid batteries that have a nominal voltage of 2.0 volts per cell. NiCad/NiFe batteries (also called alkaline batteries) have a nominal cell voltage of 1.2 volts per cell. The nominal voltage of a NiCad/NiFe battery bank can be made the same as a lead acid bank just by juggling the number of cells (10 cells for 12 volts, 20 cells for 24 volts and 40 cells for 48 volt systems) However, the NiCad/NiFe battery bank must be charged to a higher voltage to fully recharge and will drop to a lower voltage during discharging compared to a similarly sized lead acid type battery. This makes the job for the inverter/charger much more difficult.

The easiest way to use NiCad/NiFe batteries with a 24 volt inverter is to use nineteen NiCad/NiFe cells in the battery bank instead of the usual twenty. This will reduce the battery bank charging voltage requirements to about the same level as a lead-acid bank; so more standard charger settings can be used. The problem with this approach is that the battery voltage will drop as low as 18 volts to fully discharge the battery.

A second option on 12, 24 and 48-volt systems is to adjust the **BULK VOLTS DC** to its maximum setting. This will provide a complete charge although it may require a longer charging period to completely recharge the battery compared to using a higher charge voltage (or lesser number of cells) were used. The **ABSORPTION TIME** setting may be set shorter than with lead acid batteries since NiCad/NiFe batteries do not require an absorption stage. If the battery storage requirements are large, industrial grade 2 volt batteries are often more suitable.

**Note:** In alternative energy applications (solar, wind, hydro) all DC charge controllers must be set to a level below the inverter **HIGH BATTERY CUT OUT** setting or the inverter may shut off unexpectedly.

## BATTERY BANK SIZING

Batteries are the inverter's fuel tank. The larger the batteries, the longer the inverter can operate before recharging is necessary. An undersized battery bank results in reduced battery life and disappointing system performance.

Batteries should not be discharged more than 50% of their capacity on a regular basis. Under extreme conditions (such as a severe storm or a long utility outage), cycling to a discharge level of 80% is acceptable. Totally discharging a battery may result in permanent damage and reduced life.

For stand-alone applications, it is common to size a battery to provide between 3 and 5 days worth of storage before the battery requires recharging. The power contribution from other charging sources is not included in this calculation to duplicate the conditions present during a cloudy or windless period. This is often referred to as the "number of days of autonomy". If the system is a hybrid system with daily generator run periods, then the battery size may be smaller. During cloudy periods, the generator would be expected to run longer.

Utility connected applications often have very small batteries. If the system does not provide utility back-up function, the minimum battery capacity recommended is 320 amp-hours @ 12 vdc, 160 amp-hours @ 24 vdc, and 80 amp-hours @ 48 vdc. If utility back up is required, larger batteries will be needed.

## ESTIMATING BATTERY REQUIREMENTS

In order to determine the proper battery bank size, it is necessary to compute the number of amhours that will be used between charging cycles. When the required amhours are known, size the batteries at approximately twice this amount. Doubling the expected amhour usage ensures that the batteries will not be overly discharged and extends battery life. To compute total amhours usage, the amhour requirements of each appliance that is to be used are determined and then added together.

You can compute your battery requirements using the nameplate rating of your appliances. The critical formula is **WATTS = VOLTS X AMPS**. Divide the wattage of your load by the battery voltage to determine the amperage the load will draw from the batteries.

If the AC current is known, then the battery amperage will be:

$$\frac{(\text{AC current}) \times (\text{AC voltage})}{(\text{battery voltage})} = \text{DC amps}$$

Multiply the amperage by the number of hours the load will operate and you have, reasonably enough, amp-hours.

Motors are normally marked with their running current rather than their starting current. Starting current may be 3 to 6 times running current. Manufacturer literature may provide more accurate information compared to the motor nameplate. If large motors will be started, increase the battery size to allow for the high demand start-ups require.

Follow this procedure for each item you want to use with the inverter. Add the resulting amp hour requirements for each load to arrive at a total requirement. The minimum properly sized battery bank will be approximately double this amount. This will allow the battery to be cycled only 50% on a regular basis.

# TECHNICAL INFORMATION

## EXAMPLE

Complete the steps that follow to calculate your battery bank capacity. No two installations will require exactly the same battery bank capacity. The example that follows will provide a guideline for determining your needs. Read through the example and then complete the worksheet on the following page.

**STEP 1-4:** Determine your Average Daily Watt-Hours Needed.

AC APPLIANCE	STEP 1	STEP 2	STEP 3	STEP 4
	APPLIANCE RUNNING WATTS	(X) HOURS USED EACH DAY	(X) DAYS USED EACH WEEK	(, 7 = ) AVERAGE DAILY WATT-HOURS NEEDED
Microwave	600	0.5	7	300
Lights (x4)	40	6	7	240
Hair Dryer	750	0.25	3	81
Television	100	4	7	400
Washer	375	1	2	107
Refrigerator*	480/3 = 160	24	7	3840
Vacuum cleaner	1200	1	1	171

**STEP 1:** Determine what appliances the inverter will power and enter the *Appliance Running Wattage* of each appliance.

\* *Refrigerators and icemakers typically only run about 1/3 of the time, therefore the running wattage is 1/3 of the total wattage of the appliance.*

**STEP 2:** Determine the number of hours (or fractions of hours) you will use the appliance each day;

**STEP 3:** Multiply the number of days you will use the appliance during the week; this is your *Weekly Watt-Hours Needed*;

**STEP 4:** Divide your *Weekly Watt-Hours Needed* by 7 to obtain the *Average Daily Watt-Hours Needed*;

**STEP 5:** Total *Average Daily Watt-Hours Needed* to determine your *Total Daily Watt-Hours Needed*.

**STEP 6:** Multiply your *Total Daily Watt-Hours Needed* (Step 5) by the number of anticipated days of autonomy (days between charging, usually 1 to 5) to determine your *Autonomy Battery Size* (example used 3 days).

**STEP 7:** Multiply your *Autonomy Battery Estimate* (Step 6) x 2 to allow for a 50% maximum battery discharge in normal operation and an additional 50% for emergency situations to obtain your *Rough Battery Size* in watt-hours.

**STEP 8:** Determine your *Safe Battery Size* in watt-hours. Multiply your *Rough Battery Estimate* x 1.2. This allows for an efficiency of 80%. This number is your *Safe Battery Size* in watt-hours

**STEP 9:** Convert your *Safe Battery Size* to amp-hours. Divide *Safe Battery Size* by the DC system voltage (i.e., 12, 24 or 48 VDC; example used 24-volts). This number is your *Safe Battery Size* in amp-hours, which is the battery bank capacity needed before recharging.

Total Daily Watt-Hours Needed	<b>5,139</b>
Autonomy Battery Size	<b>15,417</b>
Rough Battery Size Watt-Hours	<b>30,834</b>
Safe Battery Size (Watt-Hours)	<b>37,001</b>
Safe Battery Size (Amp-Hours)	<b>1,542</b>

## WORKSHEET

Complete the steps that follow to calculate your battery bank capacity.

**STEP 1-4:** Determine your Average Daily Watt-Hours Needed.

AC APPLIANCE	STEP 1	STEP 2	STEP 3	STEP 4
	APPLIANCE RUNNING WATTS	(X) HOURS USED EACH DAY	(X) DAYS USED EACH WEEK	(, 7 = ) AVERAGE DAILY WATT-HOURS NEEDED

**STEP 1:** Determine what appliances the inverter will power and enter the *Appliance Running Wattage* of each appliance.

**STEP 2:** Determine the number of hours (or fractions of hours) you will use the appliance each day;

**STEP 3:** Multiply the number of days you will use the appliance during the week; this is your *Weekly Watt-Hours Needed*;

**STEP 4:** Divide your *Weekly Watt-Hours Needed* by 7 to obtain the *Average Daily Watt-Hours Needed*;

**STEP 5:** Total *Average Daily Watt-Hours Needed* to determine your *Total Daily Watt-Hours Needed*.

**STEP 6:** Multiply your *Total Daily Watt-Hours Needed* (Step 5) by the number of anticipated days of autonomy (days between charging, usually 1 to 5) to determine your *Autonomy Battery Size* (example used 3 days).

**STEP 7:** Multiply your *Autonomy Battery Estimate* (Step 6) x 2 to allow for a 50% maximum battery discharge in normal operation and an additional 50% for emergency situations to obtain your *Rough Battery Size* in watt-hours.

**STEP 8:** Determine your *Safe Battery Size* in watt-hours. Multiply your *Rough Battery Estimate* x 1.2. This allows for an efficiency of 80%. This number is your *Safe Battery Size* in watt-hours

**STEP 9:** Convert your *Safe Battery Size* to amp-hours. Divide *Safe Battery Size* by the DC system voltage (i.e., 12, 24 or 48 VDC; example used 24-volts). This number is your *Safe Battery Size* in amp-hours, which is the battery bank capacity needed before recharging.

Total Daily Watt-Hours Needed
Autonomy Battery Size
Rough Battery Size Watt-Hours
Safe Battery Size (Watt-Hours)
Safe Battery Size (Amp-Hours)

# TECHNICAL INFORMATION

Table 7, Typical Wattage of Common Appliances

TYPICAL APPLIANCE WATTS			
Appliance	Watts	Appliance	Watts
One FL Light	10	Blender	400
Computer	200 - 350	Toaster	1000
Black & White TV (12")	100 - 500	Hot Plate	1800
Microwave (compact)	600 - 800	Washer/Dryer	375 - 1000
Microwave (full size)	1500	Blender	400
Stereo or VCR	50	3/8" Drill	500
Color TV (19")	150	Hair Dryer or Iron	1000
*Refrigerator (3 cu ft)	180	Vacuum or coffee maker	1200
*Refrigerator (12 cu ft)	480		

*\*Refrigerators and icemakers typically only run about 1/3 of the time, therefore the running wattage is 1/3 of the total wattage of the appliance.*

## BATTERY CARE AND MAINTENANCE

If you have read the battery charger mode section of this manual, you already have a good idea of the stages of battery charging that combine to promote fast charging and ensure long battery life. Basically, there are five charger-related considerations to properly care for your batteries.

- **Charge Rate** - The maximum safe charge rate is related to the size and type of your batteries. Standard vented lead acid batteries (with battery caps) can be charged at a high rate - equal to their capacity. Small batteries may require a lower charge rate. Check with the battery manufacturer. Adjust the **MAX CHARGE AMPS AC** setting to control the charging rate.
- **Bulk Voltage** - This is the maximum voltage the batteries reach during the normal charging process. Gel cell batteries are usually set to a lower value, while non-sealed batteries are set to the higher. Adjust the **BULK VOLTS DC** setting to control the battery voltage during the **BULK** and **ABSORPTION** stages.
- **Float Voltage** - The batteries experience less gassing if they are maintained at a lower voltage than the voltage at which they are charged. Adjust the **FLOAT VOLTS DC** setting to control the battery voltage.
- **Temperature Compensation** - Temperature affects the optimum voltage values for the bulk and float charging stages. The Battery Temperature Sensor (BTS) automatically fine-tunes these voltages for you.
- **Equalization (Non-Sealed Batteries Only)** - Every month or two, batteries may need to be "equalized." (A fancy term for over-charged.) Since the individual battery cells are not exactly identical, some may still have sulfate on their plates after a complete charge cycle. On the other hand, if the batteries never received a full charge, all plates will have sulfate left on them. If the sulfate remains on the plates for an extended period of time, it will harden and seal off a percentage of the plate area, reducing the capacity of the battery. By equalizing the batteries, the entire sulfate is removed from the plates. Additionally, the gassing that result stirs up the electrolyte which tends to stratify. Stratification concentrates the sulfuric acid in the bottom of the cell while the top becomes watery. This corrodes the plates. Equalization is accomplished by charging batteries above a voltage of 2.5 VDC per cell. This is over 15 VDC for a 12 VDC system, 30 for a 24 VDC system and 60 for a 48 VDC system.

**CAUTION:** Equalization should be done only with standard electrolyte batteries. If you have sealed or gel cell batteries, check first with the battery manufacturer before equalizing. DC loads should be disconnected before equalization to protect them from damage by the high battery voltage involved.

*Table 8, Battery Charging: Charging Setpoints*

<b>TYPICAL BULK AND FLOAT SETPOINTS FOR COMMON BATTERY TYPES</b>			
<b>Battery Type</b>	<b>Bulk Volts</b>	<b>Float Volts</b>	<b>Equalizing Charge Process</b>
Sealed Gel Lead Acid battery	14.1 VDC BULK	13.6 VDC FLOAT	Not Recommended - Consult manufacturer
A.G.M. Lead Acid battery	14.4 VDC BULK	13.4 VDC FLOAT	Charge to 15.5 VDC or as per manufacturer
Maintenance-Free RV/Marine Lead Calcium Battery	14.4 VDC BULK	13.4 VDC FLOAT	Not Recommended - Consult manufacturer
Deep-Cycle, Liquid Electrolyte Lead Antimony Battery	14.6 VDC BULK	13.4 VDC FLOAT	Charge to 15.5 VDC or as per manufacturer
NiCad or NiFe Alkaline Battery (using 10 cells in series)	16.0 VDC BULK	14.5 VDC FLOAT	Consult manufacturer

*Note: Values shown are for 12-volt systems. For 24-volt systems, multiply the settings shown by 2. For 48-volt systems, multiply the settings shown by 4. These settings are guidelines, refer to your battery manufacturer for specific settings.*

# TECHNICAL INFORMATION

---

## MONTHLY MAINTENANCE

At the minimum, check the level of the electrolyte in each battery cell once a month. It should be above the top of the plates but not completely full. Most batteries have a plastic cup that the electrolyte should just touch when full. Don't overfill the batteries or the electrolyte will spill out of the batteries when they are being charged. Only refill the batteries with distilled water - "spring" water and regular tap water may have high levels of minerals that can poison the battery chemistry and reduce battery life.

It is also good to check the battery interconnections for tightness and corrosion. If any corrosion is found, disconnect the cables and carefully clean with a mild solution of baking soda and water. **DO NOT ALLOW THE SOLUTION TO ENTER THE BATTERY.** Rinse the top of the battery with clean water when finished.

To reduce the amount of corrosion on the battery terminals, coat them with a thin layer of petroleum jelly or anti-corrosion grease available from automotive parts stores or battery suppliers. Do not apply any material between the terminal and the cable lugs - the connection should be metal to metal. Apply the protective material after the bolts have been tightened.

## BATTERY STATE OF CHARGE

A good estimate of a battery's state of charge can be made by measuring the voltage across the battery terminals with the battery at rest (No energy input, no energy output) for at least three hours. These readings are best taken in the early morning, at or before sunrise, or in late evening. Take the reading while almost all loads are off and no charging sources are producing power. Connect a voltmeter across the positive and negative outputs of the battery or battery bank. Voltages are for a 12-volt battery system. For 24 volt systems multiply by 2, for 48 volt system, multiply by 4. Monitor your cell voltage, if you measure more than a .2 volt difference between each cell, you may need to equalize (Do not equalize Gel Cell Batteries). The following table will allow conversion of the readings obtained to an estimate of state of charge. The table is good for batteries at 77°F that have been at rest for 3 hours or more. If the batteries are at a lower temperature, you can expect lower voltage readings.

*Table 9, Battery State of Charge Voltage Table*

PERCENT OF FULL CHARGE	12 VOLT DC SYSTEM	CELL VOLTAGE
100%	12.7	2.12
90%	12.6	2.10
80%	12.5	2.08
70%	12.3	2.05
60%	12.2	2.03
50%	12.1	2.02
40%	12.0	2.00
30%	11.8	1.97
20%	11.7	1.95
10%	11.6	1.93
0%	<=11.6	<=1.93



## BATTERY INSTALLATION

**CAUTION:** Batteries can produce extremely high currents if they are short-circuited. Be very careful when working around them. Read the important safety instructions at the start of this manual and the battery suppliers precautions before installing the inverter and batteries.

### LOCATION

Batteries should be located in an accessible location with nothing restricting the access to the battery caps. At least 2 feet of clearance above is recommended. They must be located as close as possible to the inverter, but not limit access to the inverter and the inverter's disconnected. With the PS Series inverter (wall mounted), the batteries are best located to the right side, where the DC connections are located.

Battery to inverter cabling should be only as long as required. For 12 VDC systems, do not exceed 5 feet (one way) if 4/0 AWG cables are used. For 24 VDC systems, do not exceed 10 feet (one way) if 4/0 AWG cables are used. For 48 VDC cables, do not exceed 10 feet (one way) if 2/0 AWG cables are used, or 20 feet (one way) if 4/0 AWG cables are used.

### BATTERY ENCLOSURES

The batteries must be protected inside of a ventilated, lockable enclosure or room to prevent access by untrained personnel. The enclosure should be ventilated to the outdoors from the highest point to prevent accumulation of hydrogen gasses released in the battery charging process. An air intake should also be provided at a low point in the enclosure to allow air to enter the enclosure to promote good ventilation. For most systems, a 1-inch diameter vent pipe from the top of the enclosure is adequate to prevent accumulation of hydrogen. A sloped top can help direct the hydrogen to the vent location and prevent pockets of hydrogen from occurring. The enclosure should also be capable of holding at least one battery cell's worth of electrolyte in case a spill or leak occurs. It should be made of acid resistant material or have an acid resistant finish applied to resist the corrosion from spilled electrolyte and fumes released. If the batteries are located outside, the enclosure should be rainproof and include mesh screens over any openings to prevent insects and mice from entering. Before putting the batteries in, cover the bottom of the enclosure with a layer of baking soda to neutralize any acid that might be spilled in the future.

### BATTERY TEMPERATURE

The effective capacity of a battery is reduced when cold. This phenomenon is more significant with lead acid type batteries compared to alkaline types. When the internal temperature of a lead acid battery is 32°F (0°C) the capacity can be reduced by as much as 50%. This effectively reduces the size of the system's "gas tank", requiring more frequent "refueling" by the back up source (usually a generator). This should be considered when designing the system. If extremely cold temperatures are expected at the location of a system, either a heated equipment room or alkaline batteries should be considered.

If the system is located in an unheated space, an insulated enclosure is highly recommended for the batteries. During the charging process, the batteries release heat due to the internal resistance of the battery. If the batteries are insulated, the heat can be kept in the batteries to keep them warmer. This will substantially increase the performance of the system.

Insulated battery enclosures also ensure that the temperatures of the individual battery cells are more consistent, preventing unequal charging which can cause battery failure (some cells will be overcharged while others are undercharged).

The batteries should also be protected from high temperature as well. This can be caused by high ambient temperatures, solar heating of the battery enclosure, or heat released by a closely located generator. High battery temperatures will result in short battery life and should be avoided by ventilating the enclosure and reducing the external heat sources by shading and insulation.

# TECHNICAL INFORMATION

## BATTERY HOOK-UP CONFIGURATIONS

Battery banks of substantial size are generally created by connecting several smaller batteries together. There are three ways to do this. Batteries can be connected in **series**, to increase voltage; in **parallel** to increase amp-hour capacity; or in **series – parallel**, to increase the voltage and capacity.

The cables which connect the individual batteries together to make a larger battery “bank” should be connected together will heavy cables. The actual size of the cable depends upon whether the batteries are connected in parallel or series. Generally, the cables should not be smaller than the inverter cables - if the main cables are 4/0 AWG, the battery interconnects should be 4/0 AWG.

**Remember, for safety and to comply with UL regulations, battery over-current protection is required in the ungrounded battery cable.**

### SERIES CONNECTION

When batteries are connected with the positive terminal of one to the negative terminal of the next, they are connected in series. In a series configuration, the battery bank has the same amp/hour rating of a single battery, but an overall voltage equal to the sum of the individual batteries. This is common with 24 volt or higher battery-inverter systems.

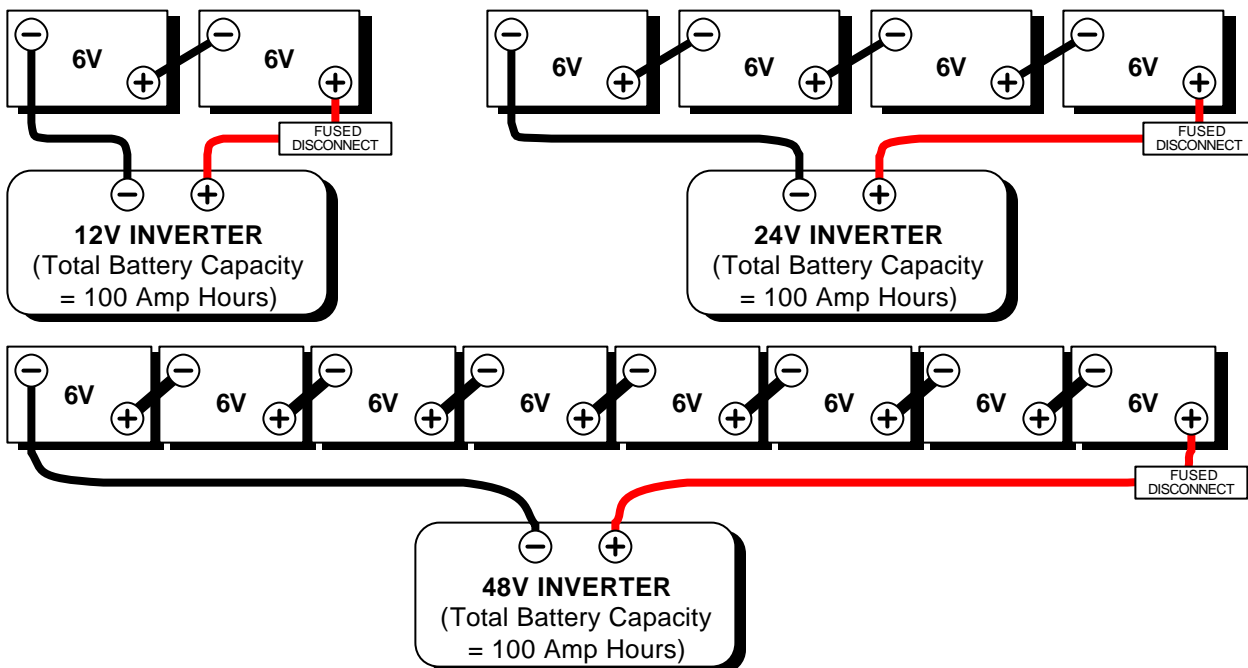

**Each individual 6-volt battery capacity = 100 amp hours**

Figure 30, Series Configuration: 6-Volt Battery Wiring

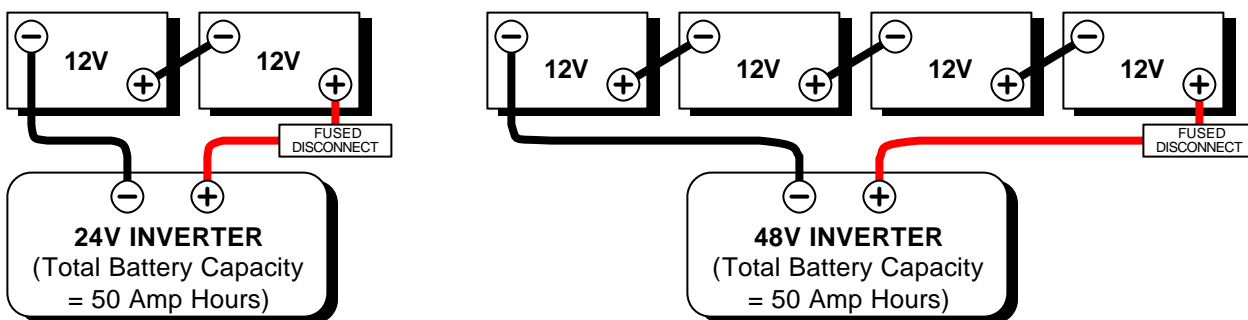

**Each individual 12-volt battery capacity = 50 amp hours**

Figure 31, Series Configuration: 12-Volt Battery Wiring

## PARALLEL CONNECTION

Batteries are connected in parallel when all the positive terminals of a group of batteries are connected and then, separately, all the negative terminals are connected. In a parallel configuration, the battery bank has the same voltage as a single battery, but an amp/hour rating equal to the sum of the individual batteries. This is usually only done with 12-volt battery-inverter systems.

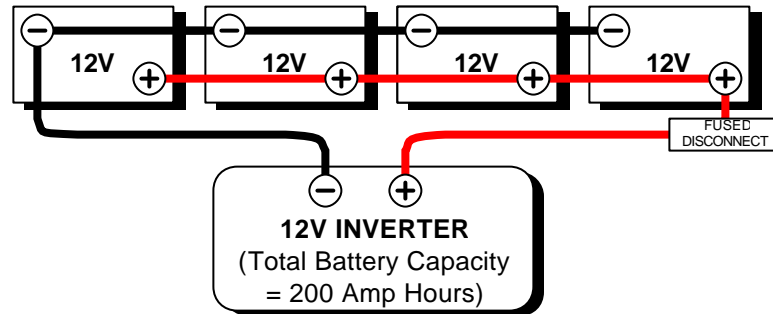

**Each individual 12-volt battery capacity = 50 amp hours**

Figure 32, Parallel Configuration: 12-Volt Battery Wiring

## SERIES - PARALLEL CONNECTION

As the name implies, both the series and parallel techniques are used in combination. The result is an increase in both the voltage and the capacity of the total battery bank. This is done to make a larger, higher voltage battery bank out of several smaller, lower voltage batteries. This is common with all battery-inverter system voltages. The smaller, lower voltage batteries are first connected in series to obtain the needed voltage, then these 'batteries, connected in series' sets are connected in parallel to increase the battery bank capacity.

The best arrangement when using a series-parallel configuration is to connect all the smaller, lower voltage batteries in parallel, then connect all these 'batteries in parallel' into series sets to obtain the needed voltage. This configuration is often called "**cross-tying**". This is less convenient and requires additional cables but reduces imbalances in the battery, can improve the overall performance, and in a "shorted cell" scenario, would cause only the battery(s) that are actually in parallel with the "shorted" battery to discharge. This would allow you to re-configure your battery bank with the other batteries that are in parallel with the shorted/discharged battery(s) and still be operational only at a lower capacity.

The more efficient "**cross-tying**" method is shown in Figure 33 and Figure 34 as "dash" (- - -) lines. If "**cross-tying**" is not desired, the dash lines shown may be ignored.

# TECHNICAL INFORMATION

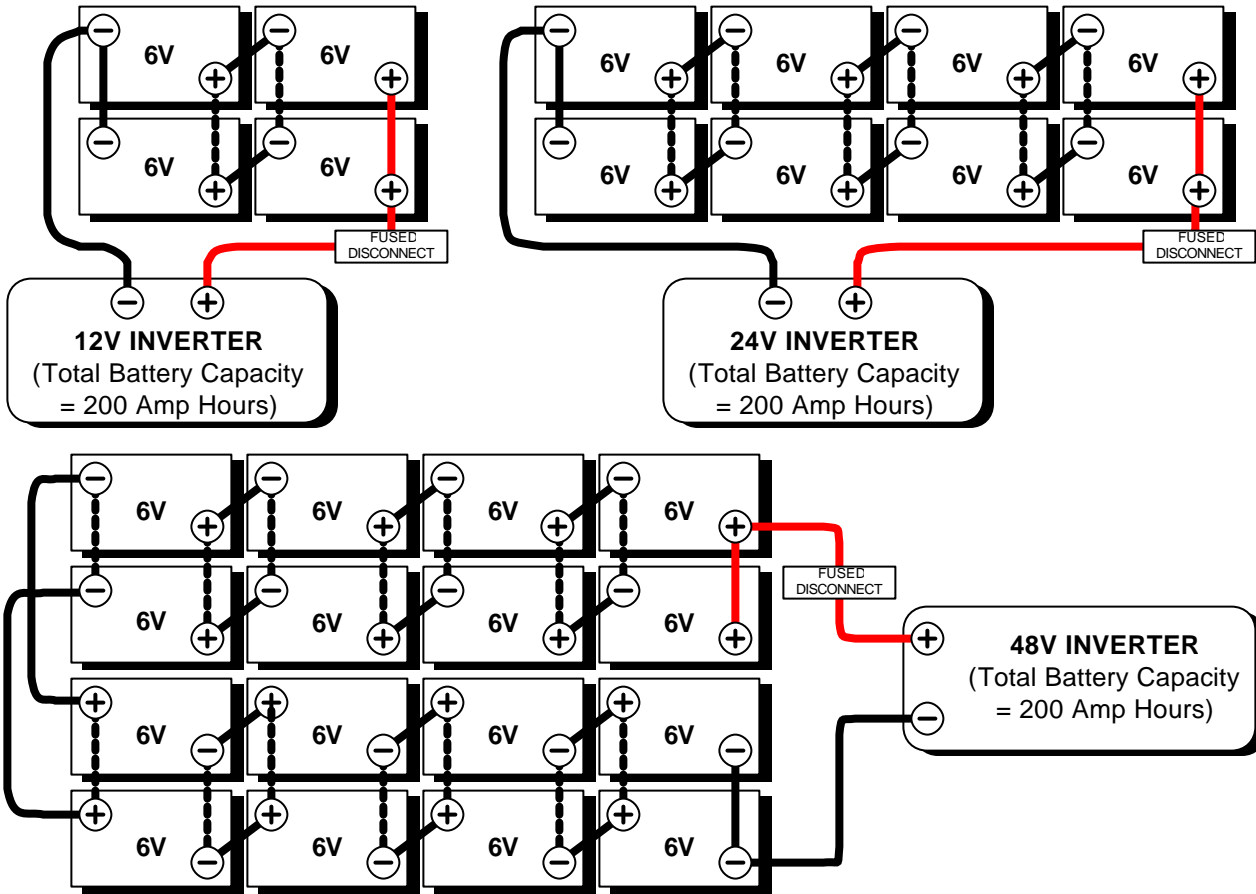

**Each individual 6-volt battery capacity = 100 amp hours**

**NOTE:** If “*cross-tying*” is not required, the “*dash*” ( - - ) connections are not needed.

Figure 33, Series-Parallel Configuration: 6-Volt Battery Wiring

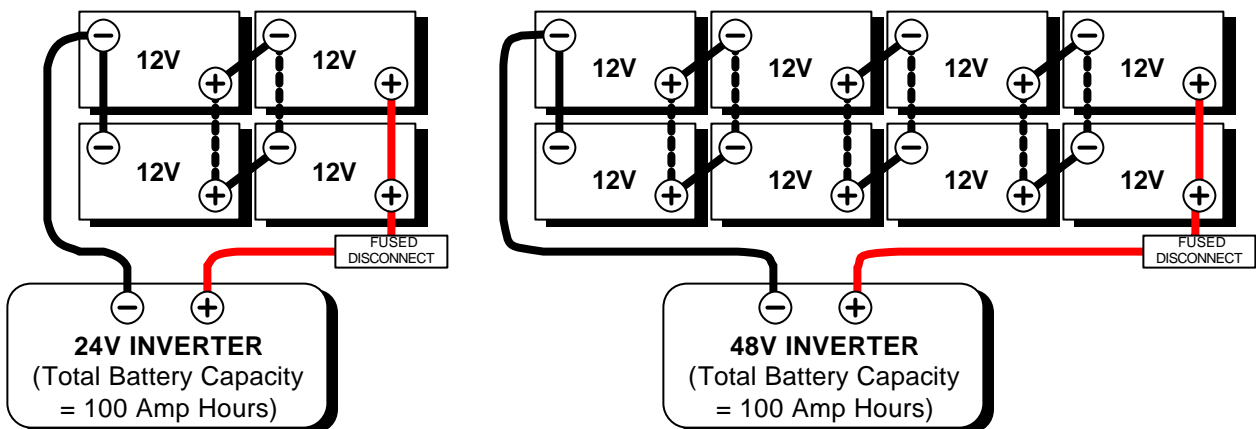

**Each individual 12-volt battery capacity = 50 amp hours**

**NOTE:** If “*cross-tying*” is not required, the “*dash*” ( - - ) connections are not needed.

Figure 34, Series-Parallel Configuration: 12-Volt Battery Wiring

## BATTERY CABLE INDUCTANCE

When current passes through a conductor a magnetic field is set up around the conductor. As this magnetic field builds, it induces voltage in any conductor that is close by, and it induces a voltage in the original conductor. The voltage induced into the original conductor is called self-inductance, and tends to oppose the current that produced it.

The magnitude of the self-induced voltage is proportional to the size of the loop formed by a wire. The larger the loop, the larger the self-induced voltage. The positive and negative battery cables in a system are in reality only a single circuit (wire), and so the inductance of the battery circuit depends on how the cables are physically positioned or arranged with respect to one another.

If battery cables are separated by a distance, they have much more inductance than if they are close together. If the two battery cables were coaxial there would be virtually no induced current flow since the magnetic fields would cancel one another. However, we don't have coaxial battery cables, but we can approximate them by taping the cables together every four to six inches. When the cables are taped together, the magnetic fields around each battery cable tend to cancel each other. When cables are separated the magnetic fields add together and increase the inductance of the battery cables. If you aren't convinced that taping battery cables together helps reduce inductance, consider the following table of information collected by Trace Engineering. We tested two sixteen foot long #4/0 AWG battery cables connected together at one end and parallel to one another.

*Table 10, Battery Cable Inductance*

<b>Distance Between Battery Cables</b>	Taped Together	12" Separation	48"+ Separation
<b>Inductance in micro-Henries</b>	3.3	6.0	8-9

The above table shows that with only a foot of distance between the battery cables the inductance almost doubles, and at four feet between cables the inductance is almost three times the inductance of cables taped together.

Since the induced voltage in a conductor varies as the inductance times the rate of change of current in the inductor, the induced voltage may be three times greater than it would be if cables were not taped together. For more advanced readers, consider flyback effects and the induced voltage spikes can get into the thousands of volts range if the battery were suddenly removed from the circuit (worst case).

These induced voltage changes cause ripple in the battery cables and must be absorbed or filtered by the filter capacitors in the inverter. This ripple will lead to eventual premature breakdown of the filter capacitors and performance loss in the inverter.

In addition to the problems mentioned, the induced current opposes the applied current (battery current) which directly causes a loss of inverter performance as greatly reduced efficiency.

To avoid this problem, route your positive and negative DC cables in parallel, as close together as possible. Secure the cables against movement with clamps or straps every 18 inches. Avoid routing conductors near heat sources such as dry exhaust or furnace piping. Avoid chafing sources such as steering cables, engine shafts, and throttle connections.

Hopefully this information gives a much more realistic and clear idea of why battery cables should be kept short and close together. Maximum performance is the goal of any well designed power system and the details such as this will help achieve the goal.

# TECHNICAL INFORMATION

---

## APPLICATIONS

### RESISTIVE LOADS

These are the loads that the inverter finds the simplest and most efficient to drive. Voltage and current are in phase, or, in this case, in step with one another. Resistive loads usually generate heat in order to accomplish their tasks. Toasters, coffee pots and incandescent lights are typical resistive loads. Larger resistive loads--such as electric stoves and water heaters--are usually impractical to run off an inverter. Even if the inverter could accommodate the load, the size of battery bank required would be impractical.

### INDUCTIVE LOADS

Any device that has a coil of wire in it probably has an inductive load characteristic. Most electronic devices have transformers (TV's, stereos, etc.) and are therefore inductive. Typically, the most inductive loads are motors. The most difficult load for the inverter to drive will be the largest motor you manage to start. With inductive loads, the rise in voltage applied to the load is not accompanied by a simultaneous rise in current. The current is delayed. The length of the delay is a measure of inductance. The current makes up for its slow start by continuing to flow after the inverter changes AC voltage polarity.

Inductive loads, by their nature, require more current to operate than a resistive load of the same wattage rating, regardless of whether power is being supplied by an inverter, a generator or grid. Induction motors (motors without brushes) require 2 to 6 times their running current on start-up. The most demanding are those that start under load e.g. compressors and some pumps. The largest motor of this type that the inverter will run varies from 1/2 to 3/4 hp. Of the capacitor-start motors, typical in drill presses, band saws, etc., the largest you may expect to run is 1 to 1.5 hp. Universal motors are generally easier to start. The inverter may start up to 2.5 hp universal motors. Since motor characteristics vary, only testing will determine if a specific load can be started and how long it can be run.

### SUBMERSIBLE WELL PUMPS

The well pump is often the hardest load for an inverter system to start. Submersible pump motors are particularly hard because the motor is very narrow (in order to fit down the well) and draws extremely high starting current.

When selecting a pump, check the **LOCKED ROTOR AMPS** in the motor specifications. This is usually the best guide to the maximum load the pump will place on the inverter. It must be less than the **MAXIMUM OUTPUT (PEAK)** listed in the **SPECIFICATIONS AND FEATURES** section on page 117 for your particular model. Pump suppliers and well drillers often oversize the pump considerably in order to reduce complaints of poor pressure, low flow, etc. Get several quotations and explain that you are very concerned about the inverter being able to power the pump. It makes sense to operate a smaller pump longer instead of a larger pump for a shorter period of time when you are powering it from batteries or a solar electric system.

When buying a pump, select a three-wire type. This refers to the electrical configuration of the power and starting windings in the pump motor. A three-wire pump requires a separate box at the top of the well for the starting circuit - a two-wire pump has the start electronics built inside. The separate starting box is preferred. If possible, select a relay type starting box instead of an all-electronic type - the relay types have been found to work better with inverters and generators. The relay types also allow use of a larger or additional starting capacitor - it may help if the inverter has a hard time starting the pump. Consult your pump supplier for more information.

If a 220/240-vac motor is required, you must either use two 120-vac inverters in a "series" stacked configuration or include a step-up transformer in the system. When used with a well pump, connect the step-up transformer after the pressure switch in order to reduce the load the transformer itself puts on the inverter. This requires that 120 vac instead of 240 vac be connected to the pressure switch.

As a last resort, consider powering the well pump directly from the generator instead of the inverter. Many systems do not have enough battery capacity or excess power to handle a load as heavy as a well pump. Using the generator with a storage tank with several days capacity may be more economical than oversizing the inverter, battery and solar array just to power the well pump.

TROUBLESHOOTING GUIDE

PS Series Troubleshooting using the LED Indicators Page 1 of 2		
ERROR CAUSES		
<b>ERROR LED is ON</b> and no other LED's are on	DC voltage on the inverter's DC terminals has been connected and is ready to turn on. The ERROR (red) LED is only indicating that the AC output is not available until you turn the unit on	
<b>ERROR LED is ON</b> and <b>INVERT LED</b> is flashing rapidly.	Determine your particular error from the causes below.	
<b>OVERCURRENT</b> Excessive load on the AC output	Disconnect <u>all</u> wires on the AC input and output. Reset the inverter by pressing the On/Off switch to OFF, then to SRCH or ON. If unit comes on, then check AC wire system (shorts or miswired)	
<b>TRANSFORMER OVERTEMP or HEATSINK OVERTEMP</b> Unit is warm/hot to the touch. Let inverter cool down and try restarting.	<u>Charging</u> : AC input voltage may be too high, check for high input ac voltage. <u>Inverting</u> : operating too large of a load for too long, remove excessive loads (a) Ambient temperature may be high (b) Inverter cooling fan may have failed – hold a piece of paper to inverter vents to check fan, (fan is hard to hear). (c) Inverter airflow intake may be blocked (small clearance or clogged).	
<b>HIGH BATTERY VOLTAGE or LOW BATTERY VOLTAGE</b> Battery voltage is not within the High or Low battery cut-out settings.	Check for the correct battery voltage at the inverter's DC input terminal. <u>High battery</u> : Ensure your DC source is regulated below your High battery cut-out. (default = 16.0 vdc) <u>Low battery</u> : Check for an external DC load on the batteries. Check the condition of your batteries and recharge if possible. (Low Battery Cut Out default = 11.0 vdc)	
<b>LOW AC INVERTER VOLTAGE</b> The AC output voltage has fallen below SET INPUT LOWER LIMIT VAC setting.	The cause for this error could be high battery voltage or an excessively large load for more than 20 seconds.	
<b>HIGH AC INPUT or LOW AC INPUT VOLTAGE</b> Detects single cycle voltage problems from the ACV input that are outside the Upper or Lower limit VAC settings.	Check for the AC voltage at the AC input terminals. Ensure the voltage is within the 'Set input Upper VAC' setting and the 'Set input Lower VAC' setting. These advisory errors last for 3 minutes only and will not disconnect the AC input. Set Upper limit VAC setting: Default = 132 VAC; Set Lower limit VAC setting: Default = 108 VAC	
INVERTER MODE- If ERROR LED comes on, see ERROR CAUSES section		
<b>Unit will not come on</b> (no LED's are on)	DC voltage on the inverter's DC terminals is incorrect.	Check the battery voltage, fuses or breakers and DC cable connections to the inverter
	DC voltage on the inverter's DC terminals is correct	Have unit serviced
<b>Unit comes on, but goes off quickly</b> (several attempts made)	Excessive load on output, unit is in over-temperature protection (needs to cool down), incorrect battery voltage. Is ERROR (red) LED on and INVERT (yellow) led flashing rapidly? See <b>ERROR CAUSES</b> section.	
<b>No AC power output</b> INVERT LED (yellow) is blinking twice with a one second pause and the ERROR LED is on.	Inverter is in the <b>CHG</b> (charge) only mode, apply AC power to begin charging and to provide AC pass-thru voltage to the output.	
<b>No AC power output</b> INVERT LED is flashing.	AC load too small for Search mode circuit to detect	Increase load above 16 watts (default setting) or defeat search mode by pressing On/Off button until INVERT LED is ON.

# TECHNICAL INFORMATION

## PS Series Troubleshooting using the LED Indicators Page 2 of 2

### INVERTER MODE - If ERROR LED comes on, see ERROR CAUSES section (continued)

<p><b>No AC power output</b> INVERT LED (yellow) is on with <u>no</u> ERROR LED.</p>	<p>Check for AC voltage on inverter's AC terminal block (Between Hot AC output and Neutral AC output).</p>	
	<p>1) If there is no AC voltage on the AC terminal block:</p>	<p>Check for open circuit breaker on PS inverter. If circuit breaker on PS inverter is not open (popped) – have inverter serviced.</p>
	<p>2) If there is AC voltage on the AC terminal block :</p>	<p>Check for open AC output breakers or fuses and bad output wire connections</p>
<p><b>Low AC power output or Low surge power and INVERT LED is on</b>  (AC inductive loads are not running at full speed).</p>	<p>Insufficient DC current being provided to the inverter to operate the AC loads</p>	<p>Check the battery voltage, fuses or breakers and cable connections.  Ensure the battery bank is sufficient (check for low DC voltage while running the load).  Ensure the cable length and size is correct (see owner's manual for correct cable). Tie the battery cables together to reduce inductance.</p>

### BATTERY CHARGER MODE - If ERROR LED comes on, see ERROR CAUSES section.

<p><b>AC IN LED is on, but will not start charging.</b> (allow 40 seconds to synchronize) Check for the correct AC voltage or frequency at the AC input terminal.</p>	<p>AC frequency at the AC input terminal is out-of- tolerance (too high or low) or AC voltage outside 'Upper/Lower VAC limit' settings</p>	<p>If AC source is a generator, adjust AC voltage or frequency accordingly.</p>
<p><b>Charger drops off before full charging has finished.</b>  Check for the correct AC voltage or frequency at the AC input terminal.</p>	<p>AC voltage or frequency at the AC input terminal drops out-of-tolerance (too high or low).</p>	<p>If AC source is generator adjust accordingly. Switch 'MAX AC Amps In' to lower AC input level.</p>
	<p>Circuit breaker on PS inverter is open</p>	<p>Engage circuit breaker on side of unit (press hard on breaker button to ensure it is engaged)</p>
	<p>Ambient temperature may be high causing unit to overheat and ramp down the charging.</p>	<p>Cool the unit down or check the inverter cooling fan, or check for anything preventing air flow</p>
<p><b>Charger drops off before full charging (or equalization) has finished</b>  ERROR LED comes on and AC output drops momentarily.</p>	<p>Cold temperature around batteries with BTS (Battery Temperature Sensor) installed may be causing unit to reach HIGH BATTERY CUTOFF setting</p>	<p>Disconnect BTS during charging.</p>
<p><b>Charger output is low</b></p>	<p>Loose or corroded battery connections</p>	<p>Check and clean all connections</p>
	<p>Loose AC input connections</p>	<p>Check all AC wiring connections</p>
	<p>Weak/soft batteries</p>	<p>Replace batteries</p>
	<p>Battery cables too small or too long</p>	<p>Refer to cable and battery recommendations in owner's manual</p>
<p><b>Batteries being charged above the Bulk/Float setting</b></p>	<p>NOTE: To bring batteries that are cold to the correct state of charge may require charging at a higher voltage. Remove the BTS and determine if your voltage returns to the bulk/float voltage</p>	
<p>Temperature probe is installed</p>	<p>Ensure that the temperature probe is not in a cold area or has not fallen off the batteries.  Ensure that there is no other DC charging source on the batteries</p>	
<p>Temperature probe is not installed</p>	<p>Ensure that there is no other DC charging source on the batteries</p>	



## TROUBLESHOOTING GUIDE

<b>PS Series Troubleshooting using the SWRC</b>		Page 1 of 3
<b>ERROR CAUSES</b>		
<b>OVERCURRENT</b> Excessive load on the AC output	Disconnect <u>all</u> wires on the AC input and output.  Reset the inverter by pressing the On/Off switch to OFF, then to SRCH or ON. If unit comes on, then check AC wire system (shorts or miswired)	
<b>TRANSFORMER OVERTEMP or HEATSINK OVERTEMP</b>	<u>Charging</u> : AC input voltage may be too high, check for high input ac voltage	
Unit is warm/hot to the touch Let inverter cool down and try restarting.	<u>Inverting</u> : operating too large of a load for too long, remove excessive loads  (a) Ambient temperature may be high  (b) Inverter cooling fan may have failed – hold a piece of paper to inverter vents to check fan, (fan is hard to hear).  (c) Inverter airflow intake may be blocked (small clearance or clogged).	
<b>HIGH BATTERY VOLTAGE or LOW BATTERY VOLTAGE</b>  Battery voltage is not within the High or Low battery cut-out settings.	Check for the correct battery voltage at the inverter's DC input terminals.  <u>High battery</u> : Ensure your DC source is regulated below your High battery cut-out or adjust your HIGH BATTERY CUT-OUT to a higher setting  <u>Low battery</u> : Check for an external DC load on the batteries. Check condition of batteries and recharge if possible or adjust your LOW BATTERY CUT-OUT to a lower setting.	
<b>HIGH AC INPUT or LOW AC INPUT VOLTAGE</b>  Detects single cycle voltage problems from the ACV input that are outside the Upper or Lower limit VAC settings.	Check for the AC voltage at the AC input terminals. Ensure the voltage is within the 'Set input Upper VAC' setting and the 'Set input Lower VAC' setting. These advisory errors last for 3 minutes only and will not disconnect the AC input.  Set Upper limit VAC setting: Default = 132 VAC; Set Lower limit VAC setting: Default = 108 VAC	
<b>LOW AC INVERTER VOLTAGE</b>  The AC output voltage has fallen below SET INPUT LOWER LIMIT VAC setting.	The cause for this error could be high battery voltage or an excessively large load for more than 20 seconds.	
<b>AC SOURCE WIRED TO OUTPUT</b>  Indicates that an AC source was wired directly to the AC output.	Check for proper AC input and output wiring (output of inverter is wired to an AC source)	
<b>GEN SPEED ERROR</b>  Five attempts were made to start the generator without obtaining the correct input AC voltage or frequency	Reset the auto generator start system by selecting OFF and then AUTO or ON from the SET GENERATOR menu.  Ensure the 'Maximum AC amps In' switch is in the AC2 position.	
<b>GEN STOPPED DUE TO V/F</b>  Indicates that the generator was running but was not operating within the voltage or frequency tolerances and was not able to connect	Check the generators output voltage and frequency (ensure that the 'Set Input lower or upper limit VAC' is set correctly).  Ensure the 'Maximum AC amps In' switch is in the AC2 position.	
<b>GEN MAX RUN TIME ERROR</b>  Indicates that the generator ran for a period of time that exceeded the 'SET MAX RUN TIME'	This is an <u>advisory</u> ERROR only and will not cause any other effect.	
<b>GEN FAILED TO START</b>  Indicates that five 'Auto generator start attempts' have occurred without successfully starting the generator	(a) Voltage has not reached 80 VAC to the AC input terminals during the 'MAX CRANK PERIOD'  (b) Voltage did not maintain >80 VAC for the majority of time while the inverter was charging  Ensure the 'Maximum AC amps In' switch is in the AC2 position.	

# TECHNICAL INFORMATION

## PS Series Troubleshooting using the SWRC

Page 2 of 3

### INVERTER - If ERROR LED comes on, see ERROR CAUSES section.

<p><b>Error LED is flashing (no error under ERROR CAUSES display)</b></p> <p>AC source frequency is just out of tolerance (53-57 Hz or 63-67 Hz)</p>	<p>No problem with AC source or inverter. The error LED is a visual indicator to allow you to adjust the AC frequency of your generator. (this error does not affect operation)</p>	
<p><b>Unit will not come on</b> (no LED's are on) and the SWRC Display is blank or off</p>	<p>DC voltage on the inverter's DC terminals is incorrect.</p>	<p>Check the battery voltage, fuses or breakers and DC cable connections to the inverter</p>
	<p>DC voltage on the inverter's DC terminals is correct</p>	<p>Have unit serviced</p>
<p><b>Unit comes on, but goes off quickly</b> (several attempts made)</p>	<p>Excessive load on output, unit is in over-temperature protection (needs to cool down), incorrect battery voltage. See <b>ERROR CAUSES</b> section</p>	
<p><b>No AC power output</b> INVERTING LED (SWRC) is on with no ERROR LED.</p> <p>Look at SWRC display under 'Inverter volts' and check AC voltage on <u>inverter</u> AC terminal block.</p>	<p>Correct AC voltage on SWRC display but no AC voltage on inverter AC terminal block. Check for open circuit breaker on PS inverter. If circuit breaker on PS inverter is not open (popped), have inverter serviced.</p>	
	<p>Correct AC voltage on SWRC display and on inverter AC terminal block. Check for open AC output breakers or fuses and bad output wire connections</p>	
	<p>AC voltage on SWRC display or inverter AC terminal block is incorrect: have unit serviced</p>	
<p><b>No AC power output</b> INVERT LED is flashing.</p>	<p>AC load too small for Search mode circuit to detect</p>	<p>Reduce search watts setting, increase load above search watts setting or defeat search mode by selecting <u>ON</u>.</p>
<p><b>Low AC power output or Low surge power</b> INVERT LED is on  (AC inductive loads are not running at full speed).</p>	<p>Insufficient DC current being provided to the inverter to operate the AC loads</p>	<p>Check the battery voltage, fuses or breakers and cable connections.  Ensure the battery bank is sufficient (check for low DC voltage while running the load).  Ensure the cable length and size is correct (see owner's manual for correct cable). Tie the battery cables together to reduce inductance.</p>

### BATTERY CHARGER - If ERROR LED comes on, see ERROR CAUSES section.

<p><b>Charger drops off before full charging (or equalization) has finished</b></p> <p>ERROR LED flashes and AC output drops momentarily.</p>	<p>Cold temperature around batteries with BTS (Battery Temperature Sensor) installed may be causing unit to reach HIGH BATTERY CUTOUT setting</p>	<p>Disconnect BTS during charging or increase HIGH BATTERY CUTOUT setting.</p>
<p><b>Charger drops off before full charging has finished.</b> (ERROR comes on)</p>	<p>See <b>ERROR CAUSES</b> section</p>	
<p><b>AC IN GOOD LED on SWRC is flashing, but will not start charging</b>  (allow 40 seconds to synchronize)  Check for the correct AC voltage or frequency at the AC input terminal.</p>	<p>AC frequency at the AC input terminal is out-of-tolerance (too high or low) or AC voltage outside 'Upper/Lower VAC limit' settings</p>	<p>If AC source is a generator, adjust AC voltage or frequency accordingly.</p>

## PS Series Troubleshooting using the SWRC

**BATTERY CHARGER - If ERROR LED comes on, see ERROR CAUSES section (continued).**

<p><b>Charger drops off before full charging has finished. (No ERROR comes on)</b></p> <p>Check for the correct AC voltage or frequency using the SWRC.</p>	<p>AC frequency at the AC input terminal drops out-of-tolerance (too high or low) or AC voltage falls outside 'Upper/Lower VAC limit' settings.</p>	<p>If AC source is generator, adjust AC voltage/frequency accordingly.</p> <p>Reduce your 'Set AC Amps' setting to limit the pull on the AC source.</p> <p>Open the 'Upper/Lower VAC limit' settings "window" to allow synchronization.</p>
	<p>Circuit breaker on PS inverter is open</p>	<p>Engage circuit breaker on side of unit (press <u>hard</u> on breaker button to ensure it is engaged)</p>
	<p>Ambient temperature may be high causing unit to overheat and ramp down the charging.</p>	<p>Cool the unit down or check the inverter cooling fan, or check for anything preventing air flow</p>
<p><b>Charger output is low</b></p>	<p>Loose or corroded battery connections</p>	<p>Check and clean all connections</p>
	<p>Loose AC input connections</p>	<p>Check all AC wiring connections</p>
	<p>Weak/soft batteries</p>	<p>Replace batteries</p>
	<p>Battery cables too small or too long</p>	<p>Refer to cable and battery recommendations in owner's manual</p>
<p>Batteries being charged above the Bulk/Float setting</p>	<p>NOTE: To bring batteries that are cold to the correct state of charge may require charging at a higher voltage. Remove the BTS and determine if your voltage returns to the bulk/float voltage</p>	
<p>Temperature probe is installed</p>	<p>Refer to the 'Battery TempComp volts DC' reading while charging.</p>	<p>(a) Ensure that the temperature probe is not in a cold area or has not fallen off the batteries.</p> <p>(b) Ensure that there is no other DC charging source on the batteries</p>
<p>Temperature probe is not installed</p>	<p>Refer to the "Battery actual volts DC" reading while charging.</p>	<p>Ensure that there is no other DC charging source on the batteries</p>

# TECHNICAL INFORMATION

---

## INVERTER/CHARGER TERMINOLOGY

The following is a glossary of terms with which you may not be familiar while reading this manual. They appear in the description of inverter and battery charger operation.

**Absorption Stage** - In this second stage of three stage charging, the batteries are held at a constant voltage (the bulk voltage setting) and the battery is charged to its maximum capacity.

**AC** - Alternating Current. Electrical current that varies with time. The rate at which the voltage changes polarity is the **frequency in Hertz (Hz)**.

**Ampacity** – The ampacity of a wire is its current carrying capacity with reference to the cross-sectional area of the conductors, the temperature rating of the insulation and the ambient temperature.

**Automatic Transfer Relay (inside the inverter)** - An automatic switch that switches between inverter and charger mode depending on availability of AC input power. If AC is present, the unit will be a battery charger, when AC goes away the unit becomes an inverter.

**Bulk Charge Stage** - This is the first of the three stages in three stage charging. In this stage, a constant current is fed to the batteries and as they accept the current, the battery voltage will rise.

**Current (Amps)** - The volume of electricity flowing through a conductor. Equivalent to a volume of water flowing through a hose.

**DC** - Direct Current. Electrical current that does not vary with time.

**Deep Cycle** - A deep cycle occurs when a battery is discharged to less than 20% of its capacity (80% depth-of-discharge).

**Deep Cycle Battery** - A battery designed to be routinely discharged to 20% of its maximum capacity without damage. This is the type of battery most commonly used with an inverter system.

### Digital VoltMeter (DVM):

**True RMS** - A voltmeter that incorporates a RMS converter to read true RMS for any waveform shape.

**Averaging Type** - A voltmeter that requires a sinewave waveform shape to provide an accurate reading.

**Efficiency** - Usually given as a percentage, efficiency is the ratio of the output to the input. The efficiency changes with power output levels of any inverter.

**Electrolyte** - Typically a mixture of water and sulfuric acid, it is commonly referred to as battery acid.

**Equalization** - Controlled “overcharging” of the battery causing it to bubble and mix the electrolyte. This reduces stratification.

**Float stage** - During the third stage of three stage charging, the voltage and current are reduced to a level that will trickle charge or maintenance charge the battery. This assures the battery remains fully charged even while sitting.

**Fuse or Circuit Breaker** - An electrical pressure relief valve. When current exceeds a preset limit the fuse or circuit breaker will fail before the wiring or equipment it is protecting. Circuit Breakers are usually resettable and can sometimes act as a switch to turn off power to equipment for servicing.

**Grid (The grid)** - Also called the utility grid, this refers to the public power distribution system.

**Impedance** - Opposition to flow of alternating current (AC)

**Islanding** - The condition present when the utility power grid fails and the inverter attempts to power the grid. An inverter which is “islanding protected” senses the loss of AC power from the grid and does not back feed into the grid system.

**LED** - Light Emitting Diode. A light made up of semi-conducting material.

**Line Tie** - Term used when the inverter is connected to the public power or “grid” system.

**Load(s)** - Any electrical item which draws power. (i.e. lights, radio, washer/dryer, refrigerator, etc.)

**Locked Rotor Amps** - The current drawn by an electric motor with the shaft or rotor stopped and locked in position. This can be used to determine if an inverter has enough surge current to start a motor. If the inverter is capable of producing more amperage than the locked rotor amps rating of a motor, it will most likely start the motor easily.

**Modified Sinewave** - Also called a quasi sine wave or a modified square wave. This output looks like a one step staircase. Most loads that will run from a sinewave will run from a modified sinewave. However, things such as clocks and furnace controllers may have trouble. (See graph below)

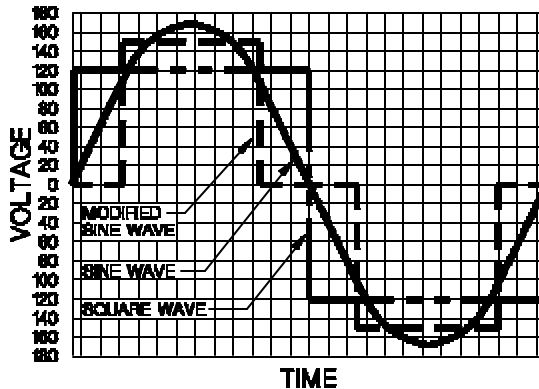

Figure 35, AC Waveforms

**NEC Code** - National Electric Code. The guidelines and acceptable practices for electrical installations. It is a book published every three years.

**Off Grid** - Not connected to public power in any way

**Output Waveform**- Shape of the wave that alternating current makes as its voltage rises and falls with time.

**Pass Through Current** - The amount of current the inverter can safely pass directly from the AC input to the AC output.

**Plates** - Originally made of lead, now fabricated from lead oxide. Plates connect to the battery terminals and provide a structure for the chemicals that create current. There are several plates in each cell; each insulated from the other by separators.

**PV** - Photovoltaic. Solar powered.

**Resistance** - The opposition to flow of direct current (DC)

**RMS** - Root Mean Square, a measure of AC voltage that would provide the equivalent heating value across a resistor as a DC source of the same voltage.

**Sellback or Selling Back To The Grid** - Some inverters have the capability to take energy stored in batteries or from solar panels and put it back into the utility grid. The Public Utility Company will then pay you for using your energy. Check with the Public Utility Company before attempting this.

**Sine Wave** – An AC waveform that looks like rolling waves on water. It rises and falls smoothly with time. The grid puts out a sine waveform. Any plug in AC equipment will operate from a sinewave output. This is shown in Figure 35, AC Waveforms.

**Square Wave** - The simplest AC waveform, this is shown in Figure 35, AC Waveforms. Some types of equipment behave strangely when run from a square wave.

# TECHNICAL INFORMATION

---

## Stacking:

**Series** - Two inverters operating together to produce twice the power and voltage of a single inverter. Required when operating 240 VAC loads and separate 120 VAC loads from either inverter.

**Parallel** - Two inverters operating together to provide twice the continuous and surge capacity on a single output circuit. Required when a single load is too large for one inverter.

The units must be stackable, and an interface cable must be utilized. See the manual for details on stacking if it is an option.

**Stratification** - Over time, a battery's electrolyte (liquid) tends to separate. The electrolyte at the top of the battery becomes watery while at the bottom it becomes more acidic. This effect is corrosive to the plates.

**Sulfating** - As a battery discharges, its plates become covered with lead sulfate. During recharging, the lead sulfate leaves the plates and recombines with the electrolyte. If the lead sulfate remains on the plates for an extended period of time (over two months), it hardens, and recharging will not remove it. This reduces the effective plate area and the battery's capacity.

**Temperature Compensation** - Peak available battery voltage is temperature dependent. As ambient temperatures fall, the proper voltage for each charge stage needs to be increased. An optional temperature-probe (BTS) automatically re-scales charge-voltage settings to compensate for ambient temperatures. The compensation slope based on cell voltage is -2.17 mv per degree Fahrenheit (30 mv per degree Celsius) per cell for lead-acid batteries.

**Voltage** - The pressure of electrical flow. Similar to water pressure in a hose.

**Watts** - Measure of power output or utilization. Watts =Volts x Amps.

## SPECIFICATIONS AND FEATURES

MODEL	PS2512	PS2524	PS2212E	PS2524E
<b>General Specifications</b>				
Continuous Power @ 25°C	2500 VA	2500 VA	2200 VA	2500 VA
Continuous Output @ 25°C	21 amps AC	21 amps AC	9.5 amps AC	11 amps AC
Nominal DC Input Voltage	12 vdc	24 vdc	12 vdc	24 vdc
AC Output (RMS)	120 VAC / 60 Hz	120 VAC / 60 Hz	230 VAC / 50 Hz	230 VAC / 50 Hz
Surge Capability	Light bulb (1)	4000 Watts	5000 Watts	3500 Watts
	1 mSec (2)	70 amps peak	90 amps peak	35 amps peak
	100 mSec (3)	40 amps RMS	50 amps RMS	20 amps RMS
Maximum Output (Peak)	45 amps AC	45 amps AC	45 amps AC	45 amps AC
Peak Efficiency	90%	92%	90%	92%
Max AC input / AC pass through	30 or 50 amps AC (via selector switch)		15 or 30 amps AC (via selector switch)	
<b>Battery Charger</b>				
Maximum Charging Rate	130 amps DC	65 amps DC	100 amps DC	65 amps DC
Charging Type	3 stage charger with temperature compensation (adjustable setpoints via SWRC or SWCA)			
Charger Power Requirement	20 amps AC	20 amps AC	8 amps AC	10 amps AC
Charger Power Factor	Power Factor Corrected / Low current distortion - 1.00 to 0.95 PF typical			
Bulk Voltage (default)	14.4 VDC	28.8 VDC	14.4 VDC	28.8 VDC
Float Voltage (default)	13.4 VDC	26.8 VDC	13.4 VDC	26.8 VDC
Absorption Time (default)	2 hours	2 hours	2 hours	2 hours
<b>DC Input Requirements</b>				
Search Mode	Less than ½ watt			
On Mode (no load - idle)	20 watts typical			
At Full Rated Power	275 amps @ 12.6 VDC	140 amps @ 25.2 VDC	240 amps @ 12.6 VDC	140 amps @ 25.2 VDC
Input Voltage Range	11.8 to 16.5 VDC	22 to 33 VDC	11.8 to 16.5 VDC	22 to 33 VDC
<b>AC Output Characteristics</b>				
AC Output Waveform	Sinewave, 34 to 52 steps per cycle			
Voltage Regulation	± 5%			
Total Harmonic Distortion	3 to 5% (stand alone operation)			
Power Factor Allowed	-1 to +1			
Frequency Regulation	± 0.04% (crystal regulated)			
Load Sensing Range	16 watts default (adjustable from 16 to 240 watts – requires SWRC or SWCA)			
<b>Standard Features</b>				
	Adjustable low battery protection			
	Battery Temperature Sensor			
	Variable brushless DC cooling fan			
	Grid interactive capable – requires SWRC or SWCA to enable the inverter to "sell" power			
<b>Options</b>				
SWRC	Full function remote control with LCD display for all PS Series inverters. SWRC (25' cable), SWRC/50FT (50' cable)			
SWCA	Communications Adapter, allows PC or modem connection			
RC8	On/Off remote control with status LED indicator (10, 25, 50 and 100 foot lengths available)			
SWI (requires two inverters)	Series stacking cable for dual PS series inverter systems for 120/240 VAC – 60 Hz output			
SWI/PAR or SWI/PAR/E	Paralleling kit for double power at 120 VAC / 60 Hz (SWI/PAR) or 230VAC / 50 Hz (SWI/PAR/E).			
PSCB	Conduit box for all PS Series inverters, fits on AC or DC end of inverter			
<b>Physical</b>				
Enclosure Type	Indoor, ventilated, aluminum chassis with powdercoat finish and screened openings			
Specified Temp Range	32°F to 104°F (0°C to 40°C) (output will meet specified tolerances)			
Allowed Temperature Range	-40°F to 140°F (-40°C to 60°C) (output may not meet specified tolerances)			
Dimensions - Inverter Only (4)	15.25" (38.7 cm) high x 22.5" (57.1 cm) wide x 6.5" (16.5 cm) deep			
Dimensions - Shipping	20" (52 cm) high x 26" (66 cm) wide x 12.75" (32.3 cm) deep			
Weight - Inverter Only	80 lbs (42 kg)			
Weight - Shipping	86 lbs (44 kg)			
<b>Approvals</b>	UL1741 / cUL to CSA 107.1		CE compliance	

**Notes:**

- (1) Surge "light bulb" - Maximum total nameplate light bulb wattage started from a cold start and powered for at least 1 minute
- (2) Surge "1 mSec" - Maximum 1 ms peak output amps measured when starting AC loads
- (3) Surge "100 mSec" - Maximum 100 ms peak output amps measured when starting AC loads
- (4) Includes 2" (5 cm) H for mounting rails and 1.5" (3.8 cm) W for DC terminals

# TECHNICAL INFORMATION

## DIMENSIONS

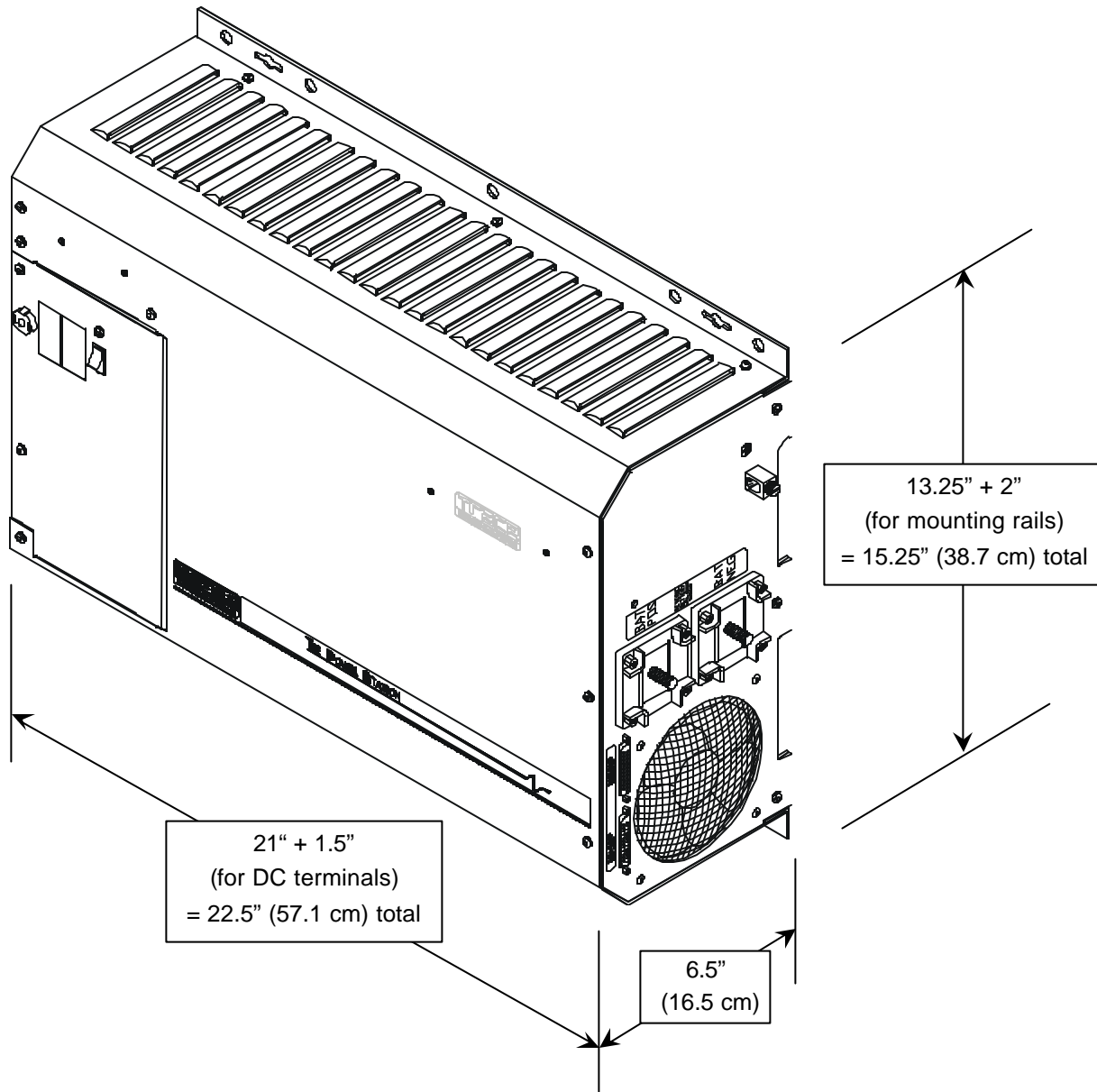

Figure 36, PS Series Dimensions



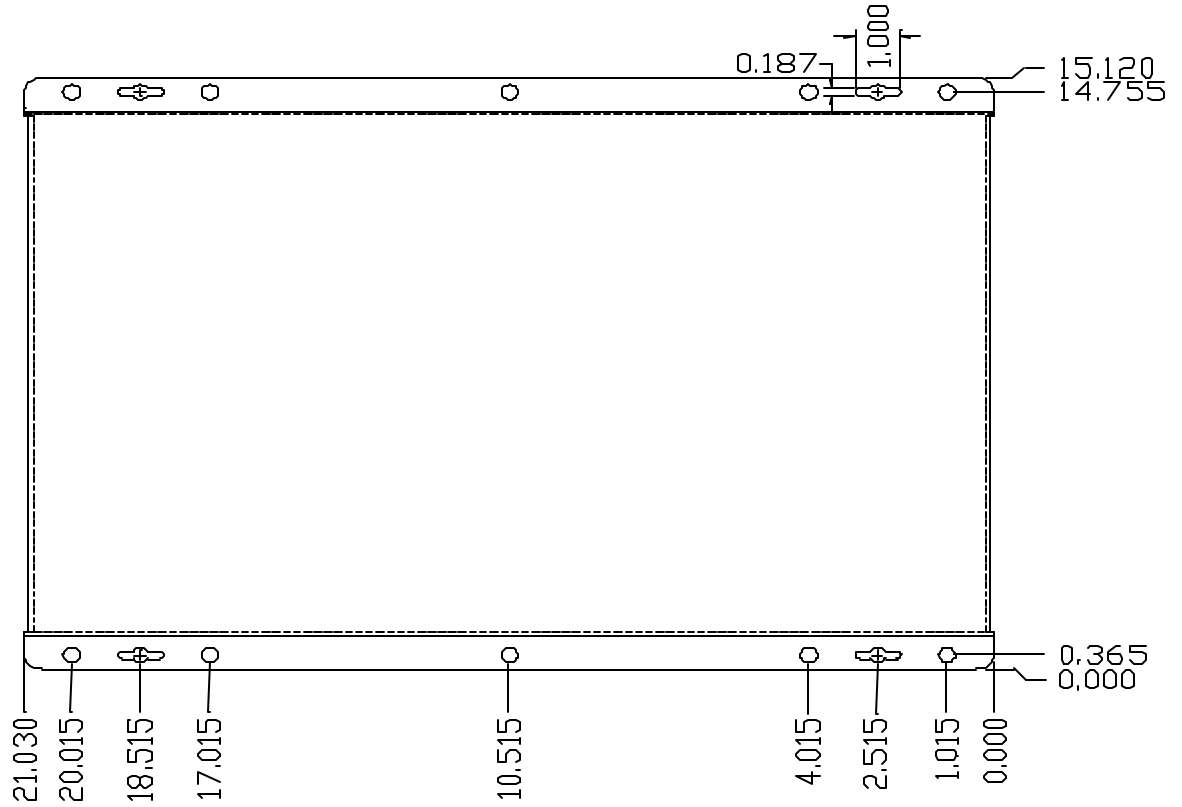

Figure 37, PS Series Bottom Plate Mounting Dimensions

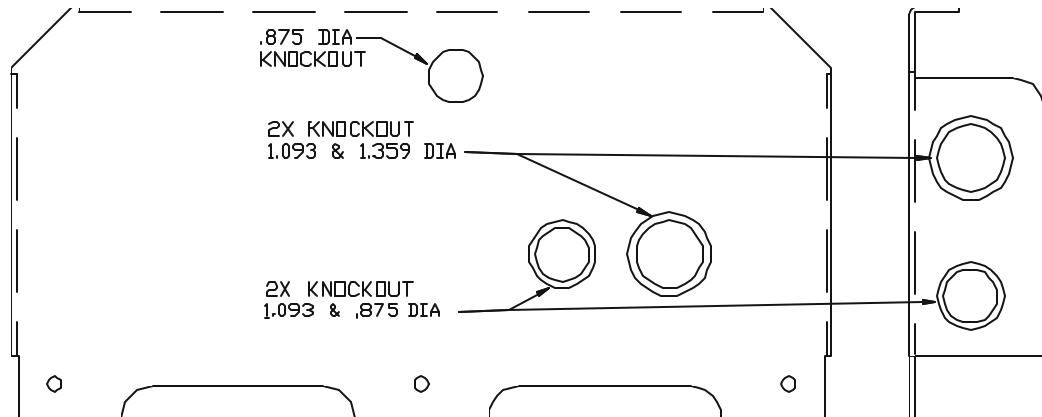

Figure 38, PS Series – Showing Knockout Sizes for AC Wiring

# TECHNICAL INFORMATION

## INSTALLATION DIAGRAMS

The following diagrams and information is provided to assist you or your system installer with the design and installation of the Trace PS Series Inverter/Charger. Due to the variety of applications, models available, and differences in local and national electrical codes, these diagrams and information should be used as general guidelines only. You must consider your application and local and national electrical codes when designing and installing your system.

For more information, please contact your Trace dealer/distributor or contact Trace Engineering directly.

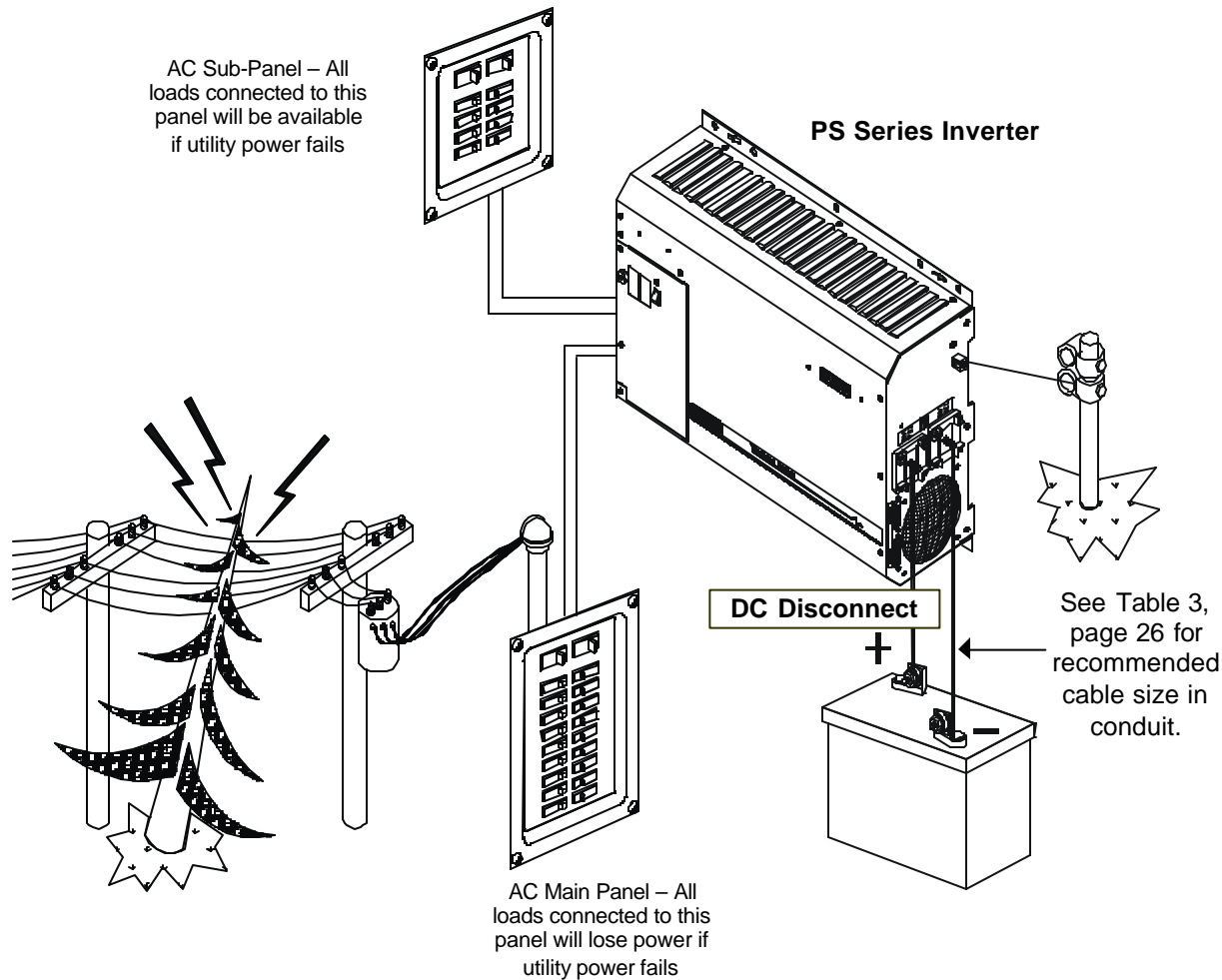

Figure 39, PS Series Installation Diagram – Stationary Backup System

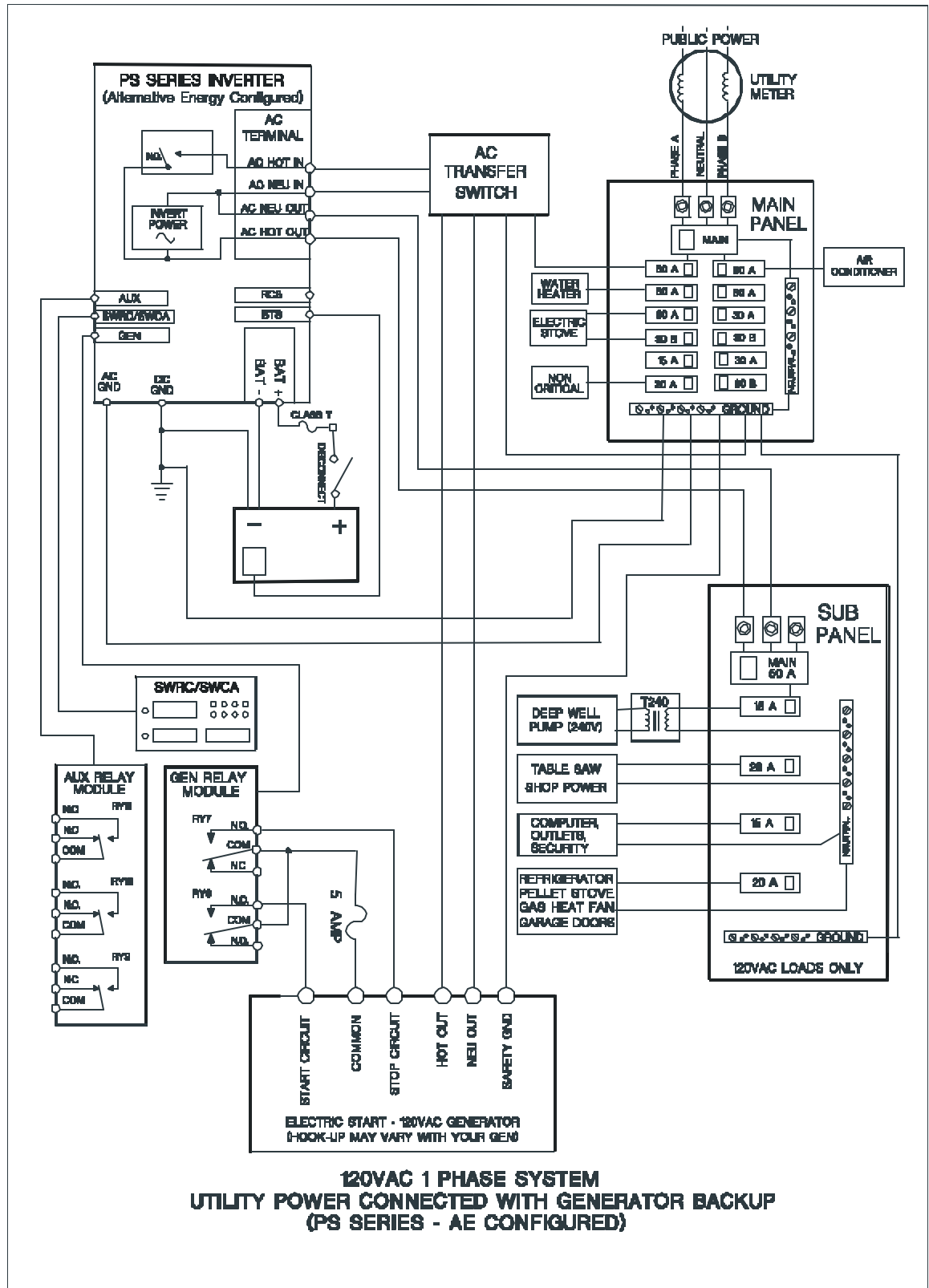

Figure 40, PS Series Installation Schematic

# TECHNICAL INFORMATION

## USER SETTINGS WORKSHEET

### USER MENU (all models)

Your PS Series Inverter/Charger may have USER and/or SETUP operating settings that are different or are changed from the standard factory settings. Use the following Record Sheets to record your specific USER and SETUP operating settings for:

PS Series Inverter/Charger S/N \_\_\_\_\_.

MENU HEADING	MENU ITEM	SELECTION RANGE	DEFAULT SETTINGS	USER SETTINGS
Inverter Mode	1 Set Inverter	OFF SRCH ON CHG	OFF	
Generator Mode	2 Set Generator	OFF AUTO ON EQ	OFF	
	Gen failed to start	DISPLAY	NO	
	Gen stopped due to V/F	DISPLAY	NO	
	Gen Max Run Time Error	DISPLAY	NO	
	Gen speed error	DISPLAY	NO	
	Load Amp Start Ready	DISPLAY	NO	
	Voltage Start Ready	DISPLAY	NO	
	Exercise Start Ready	DISPLAY	NO	
Trace Engineering	3 Revision 5.0* PS AE	DISPLAY		
Meters	4 Inverter/charger amps AC	DISPLAY	00	
	Input amps AC	DISPLAY	00	
	Load amps AC	DISPLAY	00	
	Battery actual volts DC	DISPLAY	Battery Volts	
	Battery TempComp volts DC	DISPLAY	Battery Volts	
	Inverter volts AC	DISPLAY	00	
	Grid (AC1) volts AC	DISPLAY	00	
	Generator (AC2) volts AC	DISPLAY	00	
	Read Frequency Hertz	DISPLAY	60	
	Read Bulk/EQ timer h:m	DISPLAY	00:00	
Error Causes	5 Low Battery voltage	DISPLAY	NO	
	Low inverter voltage	DISPLAY	NO	
	Low AC input voltage	DISPLAY	NO	
	High Battery voltage	DISPLAY	NO	
	High AC input voltage	DISPLAY	NO	
	Gen failed to start	DISPLAY	NO	
	Gen stopped due to V/F	DISPLAY	NO	
	Gen max run time error	DISPLAY	NO	
	Gen speed error	DISPLAY	NO	
	Over Current	DISPLAY	NO	
	Transformer overtemp	DISPLAY	NO	
	Heatsink overtemp	DISPLAY	NO	
	AC Source wired to output	DISPLAY	NO	
	External error (stacked)	DISPLAY	NO	
Time of Day	6	SET HR/MIN/SEC	00:00:00	
Generator Timer	7 Start Quiet time H:M	00:00 - 23:59	08:00	
	End Quiet time H:M	00:00 - 23:59	08:00	

\* Depending on your particular model, your software revision may be different.

## SETUP MENU (PS2512)

To access the Setup Menu, press the **RED** and **GREEN** buttons on your SWRC at the same time. To exit the Setup Menu, press the **ON/OFF MENU** button or use the down **MENU HEADING** button until you reach the User Menu (menu headings 1 – 8).

MENU HEADING	MENU ITEM	SELECTION RANGE	DEFAULT SETTINGS	USER SETTINGS
Inverter Setup	9 Set Grid Usage	FLT SELL SLT LBX	FLT	
	Set Low battery cut out VDC	08.0 - 25.5	11.0	
	Set LBCO delay minutes	00 - 255	15	
	Set Low battery cut in VDC	00.0 - 25.5	13.0	
	Set High battery cut out VDC	00.0 - 16.5	16.0	
	Set search watts	00 - 240	48	
	Set search spacing	00 - 255	59	
Battery Charging	10 Set Bulk volts DC	10.0 - 16.0	14.4	
	Set Absorption time h:m	00:00 - 23:50	02:00	
	Set Float volts DC	10.0 - 16.0	13.4	
	Set Equalize volts DC	10.0 - 16.0	14.4	
	Set Equalize time h:m	00:00 - 23:50	02:00	
	Set Max Charge amps AC	01 - 25	20	
	Set Temp Comp	LeadAcid Nicad	LeadAcid	
	Read Bulk/EQ timer h:m	DISPLAY	00:00	
AC Inputs	11 Set Grid (AC1) amps AC	00 - 50	50	
	Set Gen (AC2) amps AC	00 - 50	30	
	Set Input lower limit VAC	80 - 111	108	
	Set Input upper limit VAC	128 - 149	132	
Gen Auto Start Setup	12 Set Load Start amps AC	00 - 63	20	
	Set Load Start delay min	00.0 - 25.5	05.0	
	Set Load Stop delay min	00.0 - 25.5	05.0	
	Set 24 hr start volts DC	00.0 - 25.5	12.3	
	Set 2 hr start volts DC	00.0 - 25.5	11.8	
	Set 15 min start volts DC	00.0 - 25.5	11.3	
	Read LBCO 30 sec start VDC	DISPLAY	11.0	
	Set Exercise period days	00 - 255	30	
Set Maximum run time h:m	00:00 - 23:50	08:00		
Gen Starting Details	13 Set RY7 Function	GlowStop Run	Run	
	Set Gen warmup seconds	16 - 255	20	
	Set Pre Crank seconds	00 - 255	10	
	Set Max Cranking seconds	00 - 15	10	
	Set Post Crank seconds	00 - 255	30	
Auxiliary Relays R9 R10 R11	14 Set Relay 9 volts DC	00.0 - 25.5	14.5	
	R9 Hysteresis volts DC	00.1 - 12.8	01.0	
	Set Relay 10 volts DC	00.0 - 25.5	14.8	
	R10 Hysteresis volts DC	00.1 - 12.8	01.0	
Bulk Charge Trigger Timer	15 Start Bulk Time H:M	00:00 - 23:50	00:00	
Low Battery Transfer (LBX)	16 Set Low Battery transfer VDC	00.0 - 25.5	11.3	
	Set Low Battery cut in VDC	00.0 - 25.5	13.0	
Battery Selling	17 Set Battery Sell volts DC	10.0 - 16.0	13.4	
	Set Max Sell amps AC	01 - 25	20	
Grid Usage Timer	18 Set Start Charge time h:m	00:00 - 23:50	21:00	
	Set End Charge time h:m	00:00 - 23:50	21:00	

# TECHNICAL INFORMATION

## SETUP MENU (PS2524)

To access the Setup Menu, press the **RED** and **GREEN** buttons on your SWRC at the same time. To exit the Setup Menu, press the **ON/OFF MENU** button or use the down **MENU HEADING** button until you reach the User Menu (menu headings 1 – 8).

MENU HEADING	MENU ITEM	SELECTION RANGE	DEFAULT SETTINGS	USER SETTINGS
Inverter Setup	9 Set Grid Usage	FLT SELL SLT LBX	FLT	
	Set Low battery cut out VDC	16.0 - 35.5	22.0	
	Set LBCO delay minutes	00 - 255	15	
	Set Low battery cut in VDC	10.0 - 35.5	26.0	
	Set High battery cut out VDC	10.0 - 33.0	32.0	
	Set search watts	00 - 240	48	
	Set search spacing	00 - 255	59	
Battery Charging	10 Set Bulk volts DC	20.0 - 32.0	28.8	
	Set Absorption time h:m	00:00 - 23:50	02:00	
	Set Float volts DC	20.0 - 32.0	26.8	
	Set Equalize volts DC	20.0 - 32.0	28.8	
	Set Equalize time h:m	00:00 - 23:50	02:00	
	Set Max Charge amps AC	01 - 25	20	
	Set Temp Comp	LeadAcid Nicad	LeadAcid	
	Read Bulk/EQ timer h:m	DISPLAY	00:00	
AC Inputs	11 Set Grid (AC1) amps AC	00 - 50	50	
	Set Gen (AC2) amps AC	00 - 50	30	
	Set Input lower limit VAC	80 - 111	108	
	Set Input upper limit VAC	128 - 149	132	
Gen Auto Start Setup	12 Set Load Start amps AC	00 - 63	20	
	Set Load Start delay min	00.0 - 25.5	05.0	
	Set Load Stop delay min	00.0 - 25.5	05.0	
	Set 24 hr start volts DC	10.0 - 35.5	24.6	
	Set 2 hr start volts DC	10.0 - 35.5	23.6	
	Set 15 min start volts DC	10.0 - 35.5	22.6	
	Read LBCO 30 sec start VDC	DISPLAY	22.0	
	Set Exercise period days	00 - 255	30	
Set Maximum run time h:m	00:00 - 23:50	08:00		
Gen Starting Details	13 Set RY7 Function	GlowStop Run	Run	
	Set Gen warmup seconds	16 - 255	20	
	Set Pre Crank seconds	00 - 255	10	
	Set Max Cranking seconds	00 - 15	10	
	Set Post Crank seconds	00 - 255	30	
Auxiliary Relays R9 R10 R11	14 Set Relay 9 volts DC	10.0 - 35.5	29.0	
	R9 Hysteresis volts DC	00.1 - 12.8	02.0	
	Set Relay 10 volts DC	10.0 - 35.5	29.5	
	R10 Hysteresis volts DC	00.1 - 12.8	02.0	
Bulk Charge Trigger Timer	15 Start Bulk Time H:M	00:00 - 23:50	00:00	
Low Battery Transfer (LBX)	16 Set Low Battery transfer VDC	10.0 - 35.5	22.6	
	Set Low Battery cut in VDC	10.0 - 35.5	26.0	
Battery Selling	17 Set Battery Sell volts DC	20.0 - 32.0	26.8	
	Set Max Sell amps AC	01 - 25	20	
Grid Usage Timer	18 Set Start Charge time h:m	00:00 - 23:50	21:00	
	Set End Charge time h:m	00:00 - 23:50	21:00	

## SETUP MENU (PS2212E)

To access the Setup Menu, press the **RED** and **GREEN** buttons on your SWRC at the same time. To exit the Setup Menu, press the **ON/OFF MENU** button or use the down **MENU HEADING** button until you reach the User Menu (menu headings 1 – 8).

MENU HEADING	MENU ITEM	SELECTION RANGE	DEFAULT SETTINGS	USER SETTINGS
Inverter Setup	9 Set Grid Usage	FLT SELL SLT LBX	FLT	
	Set Low battery cut out VDC	08.0 - 25.5	11.0	
	Set LBCO delay minutes	00 - 255	15	
	Set Low battery cut in VDC	00.0 - 25.5	13.0	
	Set High battery cut out VDC	00.0 - 16.5	16.0	
	Set search watts	00 - 240	48	
	Set search spacing	00 - 255	59	
Battery Charging	10 Set Bulk volts DC	10.0 - 16.0	14.4	
	Set Absorption time h:m	00:00 - 23:50	02:00	
	Set Float volts DC	10.0 - 16.0	13.4	
	Set Equalize volts DC	10.0 - 16.0	14.4	
	Set Equalize time h:m	00:00 - 23:50	02:00	
	Set Max Charge amps AC	00.5 - 10.5	08.0	
	Set Temp Comp	LeadAcid Nicad	LeadAcid	
	Read Bulk/EQ timer h:m	DISPLAY	00:00	
AC Inputs	11 Set Grid (AC1) amps AC	00.0 - 25.0	25.0	
	Set Gen (AC2) amps AC	00.0 - 25.0	15.0	
	Set Input lower limit VAC	150 - 220	206	
	Set Input upper limit VAC	238 - 288	254	
Gen Auto Start Setup	12 Set Load Start amps AC	00.0 - 31.5	08.0	
	Set Load Start delay min	00.0 - 25.5	05.0	
	Set Load Stop delay min	00.0 - 25.5	05.0	
	Set 24 hr start volts DC	00.0 - 25.5	12.3	
	Set 2 hr start volts DC	00.0 - 25.5	11.8	
	Set 15 min start volts DC	00.0 - 25.5	11.3	
	Read LBCO 30 sec start VDC	DISPLAY	11.0	
	Set Exercise period days	00 - 255	30	
	Set Maximum run time h:m	00:00 - 23:50	08:00	
Gen Starting Details	13 Set RY7 Function	GlowStop Run	Run	
	Set Gen warmup seconds	16 - 255	20	
	Set Pre Crank seconds	00 - 255	10	
	Set Max Cranking seconds	00 - 15	10	
	Set Post Crank seconds	00 - 255	30	
Auxiliary Relays R9 R10 R11	14 Set Relay 9 volts DC	00.0 - 25.5	14.5	
	R9 Hysteresis volts DC	00.1 - 12.8	01.0	
	Set Relay 10 volts DC	00.0 - 25.5	14.8	
	R10 Hysteresis volts DC	00.1 - 12.8	01.0	
Bulk Charge Trigger Timer	15 Start Bulk Time H:M	00:00 - 23:50	00:00	
Low Battery Transfer (LBX)	16 Set Low Battery transfer VDC	00.0 - 25.5	11.3	
	Set Low Battery cut in VDC	00.0 - 25.5	13.0	
Battery Selling	17 Set Battery Sell volts DC	10.0 - 16.0	13.4	
	Set Max Sell amps AC	00.5 - 10.5	08.0	
Grid Usage Timer	18 Set Start Charge time h:m	00:00 - 23:50	21:00	
	Set End Charge time h:m	00:00 - 23:50	21:00	

# TECHNICAL INFORMATION

## SETUP MENU (PS2524E)

To access the Setup Menu, press the **RED** and **GREEN** buttons on your SWRC at the same time. To exit the Setup Menu, press the **ON/OFF MENU** button or use the down **MENU HEADING** button until you reach the User Menu (menu headings 1 – 8).

MENU HEADING	MENU ITEM	SELECTION RANGE	DEFAULT SETTINGS	USER SETTINGS
Inverter Setup	9 Set Grid Usage	FLT SELL SLT LBX	FLT	
	Set Low battery cut out VDC	16.0 - 35.5	22.0	
	Set LBCO delay minutes	00 - 255	15	
	Set Low battery cut in VDC	10.0 - 35.5	26.0	
	Set High battery cut out VDC	10.0 - 33.0	32.0	
	Set search watts	00 - 240	48	
	Set search spacing	00 - 255	59	
Battery Charging	10 Set Bulk volts DC	20.0 - 32.0	28.8	
	Set Absorption time h:m	00:00 - 23:50	02:00	
	Set Float volts DC	20.0 - 32.0	26.8	
	Set Equalize volts DC	20.0 - 32.0	28.8	
	Set Equalize time h:m	00:00 - 23:50	02:00	
	Set Max Charge amps AC	00.5 - 10.5	10.0	
	Set Temp Comp	LeadAcid Nicad	LeadAcid	
	Read Bulk/EQ timer h:m	DISPLAY	00:00	
AC Inputs	11 Set Grid (AC1) amps AC	00.0 - 25.0	25.0	
	Set Gen (AC2) amps AC	00.0 - 25.0	15.0	
	Set Input lower limit VAC	150 - 220	206	
	Set Input upper limit VAC	238 - 288	254	
Gen Auto Start Setup	12 Set Load Start amps AC	00.0 - 31.5	10.0	
	Set Load Start delay min	00.0 - 25.5	05.0	
	Set Load Stop delay min	00.0 - 25.5	05.0	
	Set 24 hr start volts DC	10.0 - 35.5	24.6	
	Set 2 hr start volts DC	10.0 - 35.5	23.6	
	Set 15 min start volts DC	10.0 - 35.5	22.6	
	Read LBCO 30 sec start VDC	DISPLAY	22.0	
	Set Exercise period days	00 - 255	30	
Gen Starting Details	13 Set RY7 Function	GlowStop Run	Run	
	Set Gen warmup seconds	16 - 255	20	
	Set Pre Crank seconds	00 - 255	10	
	Set Max Cranking seconds	00 - 15	10	
	Set Post Crank seconds	00 - 255	30	
Auxiliary Relays R9 R10 R11	14 Set Relay 9 volts DC	10.0 - 35.5	29.0	
	R9 Hysteresis volts DC	00.1 - 12.8	02.0	
	Set Relay 10 volts DC	10.0 - 35.5	29.5	
	R10 Hysteresis volts DC	00.1 - 12.8	02.0	
Bulk Charge Trigger Timer	15 Start Bulk Time H:M	00:00 - 23:50	00:00	
Low Battery Transfer (LBX)	16 Set Low Battery transfer VDC	10.0 - 35.5	22.6	
	Set Low Battery cut in VDC	10.0 - 35.5	26.0	
Battery Selling	17 Set Battery Sell volts DC	20.0 - 32.0	26.8	
	Set Max Sell amps AC	00.5 - 10.5	10.0	
Grid Usage Timer	18 Set Start Charge time h:m	00:00 - 23:50	21:00	
	Set End Charge time h:m	00:00 - 23:50	21:00	



---

## APPENDIX

### OPTIONS

Options available for the PS Series Inverter/Charger include a choice of remote controls, a conduit box and relay modules.

You may connect either the SWRC or SWCA, but they cannot be connected at the same time.

#### SWRC

The optional SWRC remote control (Trace part number **SWRC** or **SWRC/50FT**) has the ability to communicate and adjust settings in the PS Series inverter. The SWRC enables you to configure the inverter/charger to your specific system and preferences, including battery capacity, battery type, maximum charger rate Low Battery Cutoff and many more operational conditions described in the **OPERATION** section starting on page 55. In addition, the SWRC enables you to configure the optional **AUX RELAY MODULE** and **GEN RELAY MODULE** described on page 128.

The SWRC (or SWCA) is the only way, at present, to change the setpoints of the inverter. Once the desired changes have been made, the SWRC may be unplugged and these changes will be retained, unless the inverter is disconnected from DC (battery) power. When the SWRC is connected to the inverter, the inverter's status LED's still operate normally.

The SWRC displays its information on a Liquid Crystal Display (LCD) screen and eight LED indicators are provided on the SWRC to show the operating condition of the inverter, battery charger, and AC inputs and self-protection systems. The SWRC uses eight function buttons to navigate, monitor and set-up the different operational modes in the **MENU SYSTEM**. The **MENU SYSTEM** is divided into a **USER MENU** and a **SETUP MENU**. Each of the menu systems is divided into **MENU HEADINGS** and **MENU ITEMS**. The menu headings break the menu into groups of related menu items. At the menu item level, a setting can be adjusted, a mode can be selected, or information can be displayed. A menu map is provided in this manual on page 30 to help you navigate the SWRC through the many different menus.

#### SWCA

The *SineWave Communications Adapter* (Trace part number **SWCA**) serial communications interface adapter allows for remote set-up, adjustment, troubleshooting and monitoring of PS Series inverters from a personal computer and allows modem access monitoring over long distances. The SWCA allows direct access of up to eight PS Series inverters via standard telephone type wire.

The SWCA is connected to the remote control port labeled **REMOTE CONTROL SWRC / SWCA** on the right side (DC side) of the PS Series Inverter/Charger, using the provided DB-25 communications cable.

The SWCA provides the following features:

- **Remote set-up:** The SWCA is capable of direct connection to a modem for use in remote sites where a computer is not desired. This makes remote set-up simple and easy for end users, dealer, distributors or anyone familiar PS Series Inverter/Chargers. With an on-site modem and cellular communications network, costly trips are no longer necessary. Simply dial up your onsite modem and reset or adjust your systems via a virtual remote control display simulation.
- **Troubleshooting:** In the event that problems occur in the field, the SWCA can be used to do simple troubleshooting by accessing meters and error conditions from your home or office. This feature is great for new users and allows dealers to guide their customers through simple set-up and adjustment problems that would usually require on-site assistance. An ideal service program for authorized Trace service centers distributors and dealers.
- **Monitoring:** By simply paralleling the four-cable conductor, access to eight adapters is made possible. Further long-term monitoring can be made via an external data-logging device.

A menu map is provided in this manual on page 30 to help you navigate the SWCA through the many different menus.

# APPENDIX

---

## RC8 REMOTE CONTROL

The optional RC8 remote control provides an LED status of the inverter and duplicates the Power On/Off Switch on the PS Series Inverter/Charger. It connects directly to the port labeled RC8 on the AC board located under the top cover access panel (see page 13 for the location).

## PSCB CONDUIT BOX

The PSCB conduit box consists of a metal enclosure for connection to the PS Series Inverter/Charger and is provided to meet applicable codes and safety standards. The PSCB is fitted to the AC or DC side of the PS Series Inverter/Charger and has ½", ¾" and 2" knockouts for attaching conduit hardware.

## GEN RELAY MODULE

The **GEN RELAY MODULE** provides two relays (RY7 and RY8) that allows starting and stopping of both Honda and Onan type generators and an AC output fault relay (RY11) that engages when there is no AC voltage on the output.

The voltage settings that control relays RY7, RY8 and RY11 can be individually adjusted using the SWRC or SWCA. The terminals that are used to connect the external wiring and the **COM** (common) terminals of the relays are separated and both the **N.O.** (normally open) and **N.C.** (normally closed) contacts of the relays are provided.

It is much simpler to make the connections to the generator if a remote control terminal or connector is available on the generator. This sometimes requires that the generator's optional remote control be purchased. This allows examination of how the generator remote control works - which is what the inverter's generator start system in the inverter must duplicate.

Connection of the **GEN RELAY MODULE** to the generator remote control also eliminates the need to modify the generator and violate the warranty of the generator.

All wiring connected to the generator should be fused if any voltage is present at the point of connection. If in doubt, add a fuse. These relays are not intended to directly control the starter motor or operate the ignition system - rather they can be used to send a signal or operate the coil of another higher amperage device which does the actual switching of the power. The relays must be fused to prevent damage if they are miswired or a short-circuit occurs. The maximum fuse size must not exceed 5 amps. Fuses should be located as close as possible to the point of connection to the larger conductors that are providing power from the battery. You should also add a switch to allow disabling of the automatic generator start system at the generator. This will allow local control of the generator, preventing starting while servicing, etc.

Available for purchase in 2000 (2nd quarter).

## AUX RELAY MODULE

The **AUX RELAY MODULE** provides two voltage-controlled relays (RY9 and RY10) and an AC output fault relay (RY11). Relays RY9 and RY10 can perform battery voltage related tasks to simplify installations and relay RY11 engages when there is no AC voltage on the output.

The voltage settings that control relays RY9, RY10 and RY11 can be individually adjusted using the SWRC or SWCA. The terminals that are used to connect the external wiring and the **COM** (common) terminals of the relays are separated and both the **N.O.** (normally open) and **N.C.** (normally closed) contacts of the relays are provided.

The **AUX RELAY MODULE** is connected to the PS Series Inverter/Charger via the RJ11 jack located on the AC board located under the AC access cover (see page 13 for the location of the **AUX RELAY MODULE** connection). These relays are single pole double throw, five amp relays and are not intended to directly control the power sources or loads - rather they can be used to send a signal or operate the coil of another higher amperage device which does the actual switching of the power. The relays must be fused to prevent damage if they are miswired or a short-circuit occurs. The maximum fuse size must not exceed 5 amps. Fuses should be located as close as possible to the point of power from the battery.

Available for purchase in 2000 (2nd quarter).

---

## OTHER PRODUCTS

Contact your Trace Engineering dealer for details of any of the products below.

### C-SERIES MULTI-FUNCTION CONTROLLERS

The C-Series (C35, C40 and C60) controllers are the finest large-system controllers available. They may be used as a PV (solar) charge controller, DC load controller, or DC diversion regulator. The units work with 12, 24, or 48-volt DC systems (48 volt not available for the C35 or C60) and are rated at 35 to 60 amps (depending of model) continuous capacity. Other features of the C40 Multi-Function Controller are field adjustable setpoints, temperature compensation and protection, electronic overload protection with manual or auto-reset ability, optional LCD meter and an optional battery temperature compensation sensor (BTS).

### C12 CHARGE CONTROLLER

The C-12 Charge Controller is a 12 amp 3 stage solar charge controller, DC load, and automatic lighting control center. The C12 Charge Controller is fully protected against overload, short-circuit, and reverse polarity. It is ideal for controlling lighting systems as it uses a PV array as an electric eye to “see” when it is dark, so it knows when to turn on the lights! Automatic reset, battery over discharge and overcharge protection, two-stage lightning protection and surge suppression, and optional temp compensation sensor are a few of the features of the C12 Charge Controller.

### TM500 TRACE METER

The Trace TM500 is a battery status monitor that features seven data-monitoring functions that monitor battery state of charge, real-time amps, total charging amps, total load amps, days since fully charged, cumulative amp-hours; recharge and fully charged indicators. Mounts up to 50 feet from the batteries. Easily configured for liquid lead-acid or gel cell batteries. Works with 12, 24, or 48-volt systems (requires optional 48V shunt board).

### T240 - STEP-UP/STEP-DOWN (BALANCING) TRANSFORMER

The Trace T240 Transformer uses high efficiency transformer technology and is constructed with high temperature rated materials. This provides an unusually high efficiency device for voltage conversion from an inverter, generator or conventional AC source. The T240 Transformer has two identical windings that can be connected and used for line isolation, voltage step-up and step-down or generator balancing. The 3.9 Kva continuous power of the T240 Transformer is sized to take advantage of the Trace Engineering inverter line.

### OVERCURRENT PROTECTION – FUSES AND DISCONNECTS

The Trace Engineering fuseblock (TFB) protects your battery, inverter, and high amperage cables from damage by short circuits and overloads. Simply select the proper size fuseblock and install between the inverter and battery in the ungrounded conductor (typically the positive cable).

TFB's include a fast acting, current limiting class-T fuse. This fuse provides extremely fast protection when a short circuit occurs. When properly selected, it also has a time delay that allows the inverter to surge to full power without blowing the fuse.

TFB's provide the code required inverter overcurrent protection for RV and Marine applications. A slide off cover prevents accidental contact with the fuse's live terminals. For maximum protection, install the fuseblock within 18 inches (45 cm) of the battery.

For residential and commercial electrical systems, the National Electrical Code requires both overcurrent protection and a disconnect switch. Trace offers the **DC250** and **DC175** circuit breaker disconnects with enclosure for applications requiring NEC compliance. The **DC250** and **DC175** are also designed to accept 2-inch conduit to protect the inverter and battery cables.

# APPENDIX

## REFERENCE TABLES & GRAPHS

Table 11, Typical Power Consumption of Common Appliances

APPLIANCE	WATTS	TIME IN MINUTES					
		5	15	30	60	120	240
Single PL Light	10	.1	.3	.7	1.3	2.7	5.3
B & W TV	50	.4	1	2	4	8	17
Computer	100	1	2	4	8	17	34
Color TV	200	2	4	8	17	34	67
Blender	400	3	8	17	34	67	133
Skil Saw	800	6	17	34	67	133	266
Toaster	1000	8	23	46	93	185	370
Microwave	1200	10	28	57	114	227	455
Hot Plate	1800	15	44	88	176	353	706
<b>AMP-HOURS</b>							

- If the current draw at 120 VAC is known, then the battery amperage at 12 VDC will be 10 times the AC amperage divided by the efficiency (90% in this table).
- Motors are normally marked with their running rather than their starting current. Starting current can be five times running current. Keep this in mind when sizing a motor into a system.
- Refrigerators and icemakers typically run about 1/3 of the time. Therefore, their average battery current draw is 1/3 what their amp rating would indicate.

Table 12, AWG to Metric Wire Conversion Chart

AWG	DIAMETER/MM	AREA/MM <sup>2</sup>	DC RESISTANCE 1000 FT
14	1.63	2.08	3.14
12	2.05	3.31	1.98
10	2.59	5.27	1.24
8	3.26	8.35	0.778
6	4.11	13.3	0.491
4	5.19	21.2	0.308
2	6.54	33.6	0.194
1	7.35	42.4	0.154
0 (1/0)	8.25	53.4	0.122
00 (2/0)	9.27	67.5	0.0967
000 (3/0)	10.40	85.0	0.0766
0000 (4/0)	11.68	107.2	0.0608

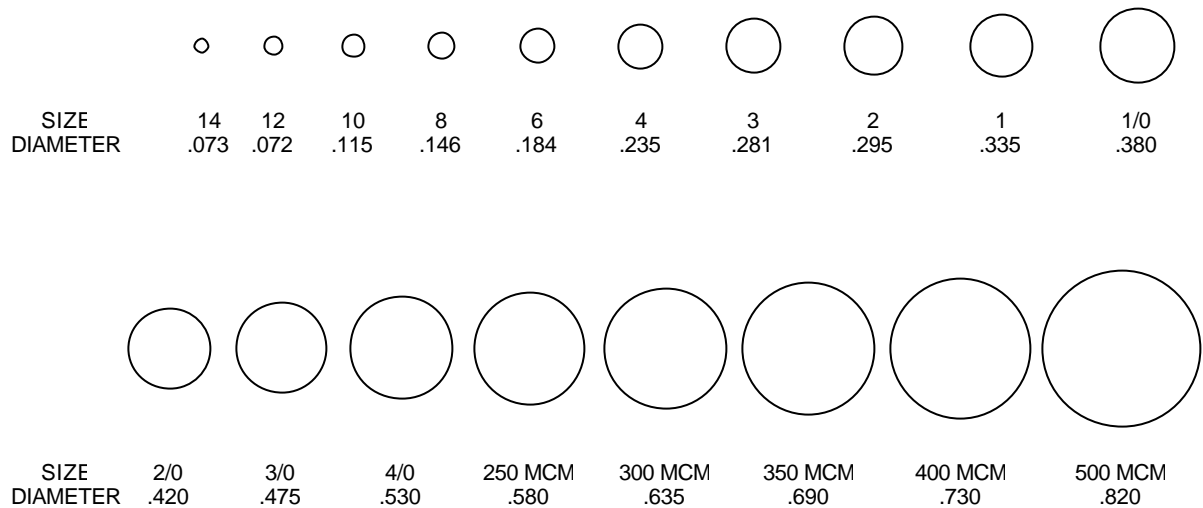

Note: Stranded wire sizes  
 Figure 41, AWG Wire Size

Table 13, Battery Cable to Maximum Breaker/Fuse Size

CABLE SIZE REQUIRED	RATING IN CONDUIT	MAXIMUM BREAKER SIZE	RATING IN "FREE AIR"	MAXIMUM FUSE SIZE
00 AWG	175 amps	175 amps	265 amps	300 amps*
0000 AWG	250 amps	250 amps**	360 amps	400 amps*

\* The NEC allows rounding up to the next standard fuse size from the cable rating, i.e. 150-amp cable size rounds up to a standard 175-amp size. The term "free air" is defined by the NEC as cabling that is not enclosed in conduit or a raceway. Cables enclosed in raceways or conduits have substantially lower continuous current carrying ability due to heating factors.

\*\* Nuisance tripping is possible if operated at 2.5 kVA continuously with a 250-amp breaker

Table 14, AC Input Default Settings

INPUT PROVISIONS	'MAXIMUM AC AMPS IN' SWITCH POSITION (120 VAC Models)	
	AC1	AC2
Inverter Lower Limit (VAC)	108	108
Inverter Upper Limit (VAC)	132	132
AC Input Current (AC Amps)	50	30
Frequency (Hz)	53 – 67 (SELL mode = 59 – 61)	53 – 67
Delay Period (seconds)	20 (SELL mode = 90)	60

INPUT PROVISIONS	'MAXIMUM AC AMPS IN' SWITCH POSITION (230 VAC Models)	
	AC1	AC2
Inverter Lower Limit (VAC)	206	206
Inverter Upper Limit (VAC)	254	254
AC Input Current (AC Amps)	25	15
Frequency (Hz)	43 – 57 (SELL mode = 49 – 51)	43 – 57
Delay Period (seconds)	20 (SELL mode = 90)	60

# APPENDIX

Table 15, Battery Charger Default Settings

	12 VDC models	24 VDC models
Set Bulk Volts DC	14.4	28.8
Set Absorption Time H:M	02:00	02:00
Set Float Volts DC	13.4	26.8
Set Equalize Volts DC	14.4	28.8
Set Equalize Time H:M	02:00	02:00
Set Max Charge Amps AC	20*	20*
Set TempComp	LEADACID	LEADACID

\* This default setting will vary between models with different continuous output power ratings.

Table 16, Minimum Recommended Battery Cable Size Vs. Cable Length

INVERTER MODEL	TYPICAL DC AMPS	1 TO 3 FEET ONE WAY	3 TO 5 FT ONE WAY	5 TO 10 FT ONE WAY
PS2512	267 amps	#4/0 AWG / 67.4 mm <sup>2</sup>	#4/0 AWG / 107 mm <sup>2</sup>	Not Recommended
PS2524/PS2524E	134 amps	#2/0 AWG / 67.4 mm <sup>2</sup>	#2/0 AWG / 67.4 mm <sup>2</sup>	#4/0 AWG / 107 mm <sup>2</sup>
PS2212E	235 amps	#2/0 AWG / 67.4 mm <sup>2</sup>	#4/0 AWG / 107 mm <sup>2</sup>	#4/0 AWG / 107 mm <sup>2</sup>

**WARNING! Battery cables that are very small will melt and burn the first time the inverter is operated at high power levels.**

Table 17, Recommended Minimum AC Wire Sizes (75° C)

INVERTER MODEL	FULL PASS-THRU CAPABILITY	MAXIMUM FUSE/BREAKER REQUIRED	CABLE SIZE REQUIRED IN CONDUIT	CABLE SIZE REQUIRED IN "FREE AIR"*
PS2512/PS2524	50 amps	60 amps	# 6 AWG (THHN)	# 8 AWG (THHN)
PS2212E/PS2524E	30 amps	30 amps	# 10 AWG (THHN)	# 12 AWG (THHN)

\* The term "free air" is defined by the NEC as cabling that is not enclosed in conduit or a raceway. Cables enclosed in raceways or conduits have substantially lower continuous current carrying ability due to heating factors.

Table 18, Safety Ground Wire Size Table

The ground wire should be sized per NEC 250-95. The following table is derived from this portion of the NEC code.

Size of overcurrent device protecting the conductor	Minimum Size of Copper Ground Wire
30 Amp or 60 Amp	#10 AWG
100 Amp	#8 AWG
200 Amp	#6 AWG
300 Amp	#4 AWG
400 Amp	#3 AWG

## WARRANTY/REPAIR INFORMATION

### LIMITED WARRANTY

Trace Engineering warrants its power products against defects in materials and workmanship for a period of two (2) years from the date of purchase and extends this warranty to all purchasers or owners of the product during the warranty period. This warranty is void under the following circumstances:

- (1) improper and/or unauthorized repair not provided by Trace Engineering or its Authorized Service Centers;
- (2) when the product is installed or exposed or exposed to an unsuitable environment as evidenced by generalized corrosion or biological infestation;
- (3) abnormal use of the product or use in violation of the instructions;
- (4) when used as a component parts of a product expressly warranted by another manufacturer.

Trace Engineering agrees to supply all parts and labor or repair or replace defects covered by this warranty with parts or products of original or improved design, at the company's option. Trace Engineering also reserves the right to improve the design of its products without obligation to modify or upgrade those previously manufactured. Defective products must be returned to Trace Engineering or its Authorized Service Center in the original packaging. The cost of transportation and insurance on items returned for service is the responsibility of the customer.

All remedies and the measure of damages are limited to the above. Trace Engineering shall in no event be liable for consequential, incidental, contingent, or special damages, even if Trace Engineering has been advised of the possibility of such damages. Any and all other warranties, expressed or implied, arising by law, course of dealing, course of performance, usage of trade or otherwise, including, but not limited to, implied warranties of merchantability and fitness for a particular purpose, are limited in duration for a period of two (2) years from the original date of purchase.

Some countries or states do not allow limitations on the term of an implied warranty, or the exclusion or limitation of incidental or consequential damage, which means the limitations and exclusions of this warranty, may not apply to you. Even though this warranty gives you specific legal rights, you may also have other rights that vary from state to state.

### WARRANTY REGISTRATION

Complete the warranty card and mail it to Trace Engineering within 10 days from the date of purchase. **Keep your bill of sale** as proof of purchase, should any difficulties arise concerning the registration of the warranty card.

Warranty Registration is tracked by model and serial numbers only, not by owner's name. Therefore, any correspondence or inquiries made to Trace Engineering must include the model and serial number of the product in question.

### LIFE SUPPORT POLICY

As a general policy, Trace Engineering, Inc. does not recommend the use of any of its products in life support applications where failure or malfunction of the Trace Engineering product can be reasonably expected to cause failure of the life support device or to significantly affect its safety or effectiveness. Trace Engineering, Inc. does not recommend the use of any of its products in direct patient care. Trace Engineering, Inc. will not knowingly sell its products for use in such applications unless it receives in writing assurances satisfactory to Trace Engineering, Inc. that (a) the risks of injury or damage have been minimized, (b) the customer assumes all such risks, and the liability of Trace Engineering, Inc. is adequately protected under the circumstances

Examples of devices considered to be life support devices are neonatal oxygen analyzers, nerve stimulators (whether used for anesthesia, pain relief, or other purposes), autotransfusion devices, blood pumps, defibrillators, arrhythmia detectors and alarms, pacemakers, hemodialysis systems, peritoneal dialysis systems, neonatal ventilator incubators, ventilators for both adults and infants, anesthesia ventilators, and infusion pumps as well as any other devices designated as "critical" by the U.S. FDA.

# WARRANTY/REPAIR INFORMATION

---

## WARRANTY OR REPAIR SERVICE REQUIRED

If your product needs repair at the factory, it must be shipped fully insured in the **original packaging** or equivalent (shipping damage is not covered under warranty and will likely delay the repair and return of your unit). The shipper will not accept any damage claims – even if insured - on products damaged through improper packaging (i.e. peanuts, soft foam, undersized boxes, etc.). If possible, avoid sending products through the mail.

Warranty or repair service should be performed only at an *Authorized Trace Service Center*, or at the Trace Engineering factory, unauthorized service performed on any Trace product will void the existing warranty.

You must notify Trace Engineering, before returning any equipment for repair, to obtain a RMA (Return Merchandise Authorization number, please contact our Warranty Coordinator at:

Phone: 360-435-8826

Fax: 360-474-0616

Email: [tracewarranty@traceengineering.com](mailto:tracewarranty@traceengineering.com)

Please provide:

Model Number: \_\_\_\_\_

Serial Number: \_\_\_\_\_

Purchase Date: \_\_\_\_\_

Problem: \_\_\_\_\_

Ship the item for repair to:

Trace Engineering Company, Inc.

Attn: Service Department.

RMA # \_\_\_\_\_

5916 195<sup>th</sup> NE

Arlington, WA 98223

Be sure to include in the package:

1. Complete return shipping address (P.O. Box numbers are not acceptable) and telephone number where you can be reached during work hours.
2. A detailed description of any problems experienced, including the make and model numbers of any other equipment in the system, types and sizes of loads, operating environment, time of unit operation and temperature.
3. If your unit has not been registered, a copy of your proof of purchase or (purchase receipt) is required for Warranty repair.

Repaired products will be returned freight C.O.D. unless sufficient return shipment funds are included with the unit.

Products sent to the factory from outside the U.S. must include return freight funds, and sender is fully responsible for all customs documents, duties, tariffs, and deposits.

Record the model and serial numbers on your product and retain for your files.



INDEX

A

Absorption Time .....96  
 AC Circuit Board .....13  
 AC Inputs, Menu (11) .....48  
 AC Maximum Output (Peak) In Amps .....117  
 AC Source Wired To Output .....12  
 AC Source Wired To Output, Menu ( 5).....42  
 AC Wiring .....18  
     AC Terminal Block.....19  
     Fuse/Breaker Size.....19, 132  
     Installation Guidelines.....20  
     Recommended Wire Sizes .....19, 132  
 Applications .....108  
 Automatic Generator Control Mode .....72  
     Generator Exercising.....74  
     Generator Starting Scenarios .....73  
         Automatically .....73  
         Manual.....73  
 Automatic Generator Start Mode .....58  
 Automatic Transfer Relay .....117  
 Aux Relay Module.....128  
     Connection .....13  
 Auxiliary Relays, Menu (14).....50  
 AWG to Metric Wire Conversion Chart.....130  
 AWG Wire Size.....131

B

Battery.....95  
     Amphour Usage .....97  
     Battery Type  
         Deep Cycle Battery .....90, 95  
             Maintenance Free.....96  
             Non-sealed Lead Acid.....95  
         NiCad/NiFe Battery.....96  
         Starting Battery .....95  
     Enclosure .....103  
     Hydrogen Sulfide Gas .....17  
     Installation.....103  
     Polarity .....23  
     Temperature .....103  
 Battery Actual Volts DC (Meter), Menu ( 4) .....39  
 Battery Cables  
     Battery To Inverter Cabling.....103  
     Cable Inductance .....107  
     Connections .....23  
     Fuse/Breaker Sizes .....22, 131  
     Induced Voltage .....107  
     Sizing.....21  
 Battery Charging  
     Absorption Time .....53, 62, 65, 86  
     Bulk Charging .....82  
     Bulk Voltage .....101  
     Charge Rate .....101  
     Charger Only Operation .....63  
     Charging Setpoints .....66, 101  
         Multiple Inverters .....94  
     Equalization .....47  
     Equalization .....37, 66  
     Equalization Charging.....67, 101  
     Float Charging .....47, 63  
     Float Voltage .....101  
     Max Charge Amps.....101  
     State of Charge .....102  
     Temperature Compensation .....47, 101  
 Battery Charging, Menu (10).....46  
 Battery Maintenance .....101  
     Monthly .....102  
 Battery Selling .....53, 82, 85, 86  
 Battery Selling, Menu (17).....52  
 Battery Sizing.....97

Example.....98  
 Worksheets .....99  
 Battery Temperature Sensor (BTS) .....63, 94  
     Connection .....14  
 Battery Terminals .....15  
 BTS (Battery Temperature Sensor) .....63  
 Bulk Charge Trigger Timer.....53, 62, 68, 81, 82, 86, 90  
 Bulk Charge Trigger Timer, Menu (15).....51  
 Bulk Charging .....82

C

C12 Charge Controller.....129  
 C40 Multi-Function Controller .....129  
 Certification .....8  
 Certification label.....8  
 Charger Mode.....58  
 Circuit Breaker  
     Branch Rated .....10  
     Inverter/Charger .....10  
 Compressors ..... See Inductive Loads  
 Conduit Box (PSCB) .....128  
 Configuration .....8  
 Contrast.....32  
 Control Wiring  
     Fusing.....73, 128  
 Controls And Indicators .....32

D

DC Ground .....15  
 DC Input Requirements .....117  
 DC Wiring .....21  
     DC Disconnect .....22  
     DC Overcurrent Protection .....22  
 Default Setting  
     AC Input.....64, 131  
     Battery Charger .....65, 132  
     End Quiet Time, Menu ( 7).....43  
     R 9 Hysteresis Volts DC, Menu (14).....51  
     R10 Hysteresis Volts DC, Menu (14).....51  
     Read LBCO 30 Sec Start Volts DC, Menu (12) .....49  
     Set 15 Min Start Volts DC, Menu (12).....49  
     Set 2 Hr Start Volts DC, Menu (12).....49  
     Set 24 Hr Start Volts DC, Menu (12).....48  
     Set Absorption Time, Menu (10).....47  
     Set Battery Sell Volts DC, Menu (17).....52  
     Set Bulk Volts DC, Menu (10).....46, 47  
     Set Clock Hour, Menu ( 6).....43  
     Set Clock Minute, Menu ( 6).....43  
     Set Clock Second, Menu ( 6).....43  
     Set End Charge Time, Menu (18).....53  
     Set Equalize Time, Menu (10) .....47  
     Set Exercise Period Days, Menu (12) .....49  
     Set Float Volts DC, Menu (10).....47  
     Set Gen Warmup Seconds, Menu (13) .....50  
     Set Generator, Menu ( 2) .....36  
     Set Grid (AC1) Amps AC, Menu (11).....48  
     Set Grid Usage, Menu ( 9).....45  
     Set High Battery Cut Out VDC, Menu ( 9) .....46  
     Set Input Lower Limit VAC, Menu (11) .....48  
     Set Input Upper Limit VAC, Menu (11) .....48  
     Set Inverter, Menu ( 1) .....36  
     Set LBCO Delay, Menu ( 9).....46  
     Set Load Start Amps AC, Menu (12).....48  
     Set Load Start Delay Min, Menu (12).....48  
     Set Load Stop Delay Min, Menu (12).....48  
     Set Low Battery Cut In VDC, Menu ( 9).....46  
     Set Low Battery Cut Out VDC, Menu ( 9) .....46  
     Set Max Charge Amps AC, Menu (10).....47  
     Set Max Cranking Seconds, Menu (13).....50  
     Set Max Sell Amps AC, Menu (17).....52  
     Set Maximum Run Time, Menu (12).....49

# INDEX

Set Post Crank Seconds, Menu (13).....	50	Gen max run time error, Menu ( 2).....	37, 41
Set Pre Crank Seconds, Menu (13).....	50	GEN Menu Button.....	34
Set Relay 9 Volts DC, Menu (14).....	51, 52	Gen Relay Module.....	73, 128
Set RY7 Function, Menu (13).....	49	Connection.....	14
Set Search Spacing, Menu ( 9).....	46	Gen Size Amps AC Setting.....	71
Set Search Watts, Menu ( 9).....	46	Gen speed error, Menu ( 2).....	37, 41
Set Start Bulk Time, Menu (15).....	51	Gen Starting Details, Menu (13).....	49
Set Start Charge Time, Menu (18).....	53	Gen stopped due to V/F, Menu ( 2).....	37, 41
Set Temp Comp, Menu (10).....	47	General Precautions.....	3
Start Quiet Time, Menu ( 7).....	43	Generator	
<b>E</b>		120/240 VAC Generators.....	71
Efficiency.....	117	Automatic Start.....	70, 72, 76, 77, 78
End Charge Time.....	53, 85, 86, 90	With Multiple Inverter/Chargers.....	94
End Quiet Time, Menu ( 7).....	43	Controlling Relays.....	50, 73
Energy Management Modes.....	58	Cool Down Period.....	74, 78
Equalization Charging.....	35, 67, 78	Equalization Charging.....	67, 78
Error cause		Exercise Period.....	49
AC Source wired to Output.....	12	Exercising.....	74, 79
External Error (stacked).....	12	Frequency.....	12, 37, 41, 42
Gen failed to start.....	12	Maximum Run Time.....	49
Gen max run time.....	12, 49	Relay Control Sequence.....	75
Gen speed error.....	12	Start Routines.....	49, 74, 76
Generator stopped due to V/F.....	12	Start Status.....	38
High AC input voltage.....	12	Starting and Stopping.....	35, 36
High Battery voltage.....	11	Starting With Multiple Inverters.....	94
Low AC input voltage.....	12	Support Mode.....	71
Low Battery voltage.....	11	Three Wire Start.....	76, 77
Low inverter voltage.....	11	Two Wire Start.....	76
Over Current.....	12	Voltage.....	37, 41
Over temperature (Heatsink).....	11	Warm-up time.....	64
Over temperature (transformer).....	11	Generator Error	
Error Causes, SWRC		Gen failed to start.....	12
AC Source Wired To Output, Menu ( 5).....	42	Gen max run time.....	12
Exercise Start Ready, Menu ( 2).....	38	Gen speed error.....	12
External Error (Stacked), Menu ( 5).....	42	Generator stopped due to V/F.....	12
Gen failed to start, Menu ( 2).....	37, 41	Generator Starting Scenarios	
Gen max run time error, Menu ( 2).....	37, 41	Automatically.....	73
Gen speed error, Menu ( 2).....	37, 41	Manual.....	73
Gen stopped due to V/F, Menu ( 2).....	37, 41	Generator Support Mode.....	58
Heatsink Overtemp, Menu ( 5).....	42	Generator Timer, Menu ( 7).....	43
High AC input voltage, Menu ( 5).....	41	GFI (Ground Fault Interrupt).....	20
High Battery Voltage, Menu ( 5).....	41	Grid Usage Timer.....	52, 68, 82, 85, 89, 90
Load Amp Start Ready, Menu ( 2).....	38	Grid Usage Timer, Menu (18).....	53
Low AC input voltage, Menu ( 5).....	40	Ground Fault Interrupt (GFI).....	20
Low Battery voltage, Menu ( 5).....	40	Ground Switching.....	14
Low Inverter voltage, Menu ( 5).....	40	Grounding.....	24
Over Current, Menu ( 5).....	42	Bonding.....	24
Transformer Overtemp, Menu ( 5).....	42	Equipment or Chassis Grounds.....	24
Voltage Start Ready, Menu ( 2).....	38	Grounding Electrodes/Ground Rods.....	24
Error LED.....	37, 41	Lightning.....	25
SWRC		Multiple Point Ground.....	25
Blinking.....	37, 42, 79	Single Point Ground.....	25
Estimating Battery Requirements.....	97	Wire size.....	132
Exercise Period.....	74	<b>H</b>	
Exercise Start Ready, Menu ( 2).....	38	Heatsink Overtemp, Menu ( 5).....	42
External AC Transfer Relays.....	20	High AC input voltage, Menu ( 5).....	41
External Error (Stacked).....	12	High Battery Cut Out.....	11
External Error (Stacked), Menu ( 5).....	42	High Battery Voltage, Menu ( 5).....	41
<b>F</b>		<b>I</b>	
Float Charging.....	47, 63	Important Safety Instructions.....	3
FLT Mode.....	45, 51, 53, 68	Induced Voltage	
Frequency Tolerance.....	64	Battery Cables.....	107
Fuse Block.....	22	Inductive Loads.....	108
Fuses And Disconnects.....	129	Information Display	
Fusing		Menu ( 1) - Inverter Mode.....	36
AC Wiring.....	19, 132	Menu ( 2) - Generator Mode.....	38
Control Wiring.....	50, 128	Menu ( 3) Trace Engineering.....	38
DC Wiring.....	22, 131	Menu ( 4) - Meters.....	40, 42
<b>G</b>		Menu (14) - Auxiliary Relays.....	51
Gen Auto Start Setup, Menu (12).....	48	Menu (17) - Battery Selling.....	52
Gen failed to start, Menu ( 2).....	37, 41	Menu (18) - Grid Usage Timer.....	53
		Menu (19) - Information File Battery.....	53

<p>Information File Battery, Menu (19).....53</p> <p>Input Amps AC (Meter), Menu ( 4 ).....39</p> <p>Input Lower Limit VAC.....37, 41, 48</p> <p>Input Requirements .....63</p> <p style="padding-left: 20px;">AC Current .....64</p> <p style="padding-left: 20px;">AC Voltage.....63</p> <p style="padding-left: 20px;">Delay Period .....64</p> <p style="padding-left: 20px;">Frequency .....64</p> <p>Input Upper Limit VAC.....37, 41</p> <p>Installation Diagrams .....120</p> <p>Installation Guidelines</p> <p style="padding-left: 20px;">AC Wiring .....20</p> <p>Introduction.....5</p> <p>Inverter</p> <p style="padding-left: 20px;">Controls and Indicators .....9</p> <p style="padding-left: 20px;">Location.....17</p> <p style="padding-left: 20px;">Mounting.....18</p> <p style="padding-left: 20px;">Theory of Operation .....55</p> <p style="padding-left: 20px;">Unpacking.....6</p> <p style="padding-left: 20px;">Ventilation.....18</p> <p>Inverter Mode .....58</p> <p style="padding-left: 20px;">Low Battery Protection .....61</p> <p>Inverter Mode, Menu ( 1 ).....36</p> <p>Inverter Setup, Menu ( 9 ).....45</p> <p>Inverter Volts AC (Meter), Menu ( 4 ) .....39</p> <p>Inverter/Charger</p> <p style="padding-left: 20px;">AC Circuit Board.....13</p> <p style="padding-left: 20px;">Circuit Breaker.....10</p> <p>Inverter/Charger Amps AC (Meter), Menu ( 4 ) .....39</p> <p>Inverter/Charger Mode .....58</p> <p>Islanding Protection.....83</p> <p><b>L</b></p> <p>LBX (Low Battery Transfer Mode) .....45, 90, 91</p> <p>LED Status Indicators.....10, 33</p> <p style="padding-left: 20px;">AC In, Green.....10</p> <p style="padding-left: 20px;">Error, Red.....11</p> <p style="padding-left: 20px;">Invert, Yellow .....11</p> <p>LED Status Indicators, SWRC</p> <p style="padding-left: 20px;">AC1 In Good (Green) .....33</p> <p style="padding-left: 20px;">AC2 In Good (Green) .....33</p> <p style="padding-left: 20px;">Bulk (Yellow).....33</p> <p style="padding-left: 20px;">Error (Red) .....34</p> <p style="padding-left: 20px;">Float (Green).....34</p> <p style="padding-left: 20px;">Inverting (Yellow).....33</p> <p style="padding-left: 20px;">Line Tie (Yellow).....33</p> <p style="padding-left: 20px;">Overcurrent (Red) .....34</p> <p>Life Support Policy .....133</p> <p>Load Amp Start Ready, Menu ( 2 ).....38</p> <p>Load Amps AC (Meter), Menu ( 4 ) .....39</p> <p>Loads</p> <p style="padding-left: 20px;">240 VAC.....71, 92</p> <p>Location.....17</p> <p>Locked Rotor Amps .....108</p> <p>Low AC input voltage .....12, 40, 41</p> <p>Low AC input voltage, Menu ( 5 ) .....40</p> <p>Low AC Output Voltage, Menu ( 5 ).....40</p> <p>Low Battery Cut In .....11</p> <p>Low Battery Cut Out .....11</p> <p>Low Battery Cut Out VDC.....40, 46, 49, 52, 61, 91</p> <p style="padding-left: 20px;">Adjustment .....61</p> <p>Low Battery Protection .....61</p> <p>Low Battery Transfer (LBX), Menu (16).....52</p> <p>Low Battery Transfer Mode (LBX) .....45, 58, 90, 91</p> <p>Low Battery volatge.....11</p> <p>Low Battery voltage, Menu ( 5 ).....40</p> <p>Low inverter voltage .....11</p>	<p>Exercise Start Ready .....38</p> <p>Gen failed to start .....41</p> <p>Gen max run time error .....37, 41</p> <p>Gen speed error.....37, 41</p> <p>Gen stopped due to V/F .....37, 41</p> <p>Generator failed to start.....37</p> <p>Information Display .....38</p> <p>Load Amp Start Ready .....38</p> <p>Set Generator.....36</p> <p>Voltage Start Ready .....38</p> <p>Menu ( 3 ) - Trace Engineering</p> <p style="padding-left: 20px;">Information Display .....38</p> <p style="padding-left: 20px;">Press Reset Now For Defaults .....38</p> <p>Menu ( 4 ) - Meters</p> <p style="padding-left: 20px;">Battery Actual Volts DC (Meter).....39</p> <p style="padding-left: 20px;">Information Display .....40, 42</p> <p style="padding-left: 20px;">Input Amps AC (Meter).....39</p> <p style="padding-left: 20px;">Inverter Volts AC (Meter).....39</p> <p style="padding-left: 20px;">Inverter/Charger Amps AC (Meter).....39</p> <p style="padding-left: 20px;">Load Amps AC (Meter).....39</p> <p style="padding-left: 20px;">Read Bulk/EQ timer.....40</p> <p style="padding-left: 20px;">Read Bulk/EQ timer .....47</p> <p style="padding-left: 20px;">Read Frequency Hertz (Meter).....40</p> <p>Menu ( 5 ) - Error Causes</p> <p style="padding-left: 20px;">AC Source Wired To Output.....42</p> <p style="padding-left: 20px;">External Error (Stacked) .....42</p> <p style="padding-left: 20px;">Heatsink Overtemp .....42</p> <p style="padding-left: 20px;">High Battery Voltage .....41</p> <p style="padding-left: 20px;">Low AC input voltage .....40</p> <p style="padding-left: 20px;">Low Battery voltage.....40</p> <p style="padding-left: 20px;">Low Inverter voltage .....40</p> <p style="padding-left: 20px;">Over Current .....42</p> <p style="padding-left: 20px;">Transformer Overtemp .....42</p> <p>Menu ( 5 ) – Error Causes</p> <p style="padding-left: 20px;">High AC input voltage.....41</p> <p>Menu ( 6 ) – Time of Day</p> <p style="padding-left: 20px;">Set Clock Hour.....43</p> <p style="padding-left: 20px;">Set Clock Minute.....43</p> <p style="padding-left: 20px;">Set Clock Second.....43</p> <p>Menu ( 7 ) – Generator Timer</p> <p style="padding-left: 20px;">End Quiet Time .....43</p> <p style="padding-left: 20px;">Start Quiet Time.....43</p> <p>Menu ( 9 ) – Inverter Setup</p> <p style="padding-left: 20px;">Set Grid Usage .....45</p> <p style="padding-left: 20px;">Set High Battery Cut Out VDC.....46</p> <p style="padding-left: 20px;">Set LBCO Delay .....46</p> <p style="padding-left: 20px;">Set Low Battery Cut In VDC.....46</p> <p style="padding-left: 20px;">Set Low Battery Cut Out VDC.....46</p> <p style="padding-left: 20px;">Set Search Spacing.....46</p> <p style="padding-left: 20px;">Set Search Watts .....46</p> <p>Menu (10) - Battery Charging</p> <p style="padding-left: 20px;">Set Absorption Time .....47</p> <p style="padding-left: 20px;">Set Bulk Volts DC .....46, 47</p> <p style="padding-left: 20px;">Set Equalize Time .....47</p> <p style="padding-left: 20px;">Set Float Volts DC .....47</p> <p style="padding-left: 20px;">Set Max Charge Amps AC.....47</p> <p style="padding-left: 20px;">Set Temp Comp.....47</p> <p>Menu (11) – AC Inputs</p> <p style="padding-left: 20px;">Set Grid (AC1) Amps AC.....48</p> <p style="padding-left: 20px;">Set Input Lower Limit VAC.....48</p> <p style="padding-left: 20px;">Set Input Upper Limit VAC.....48</p> <p>Menu (12) - Gen Auto Start Setup</p> <p style="padding-left: 20px;">Read LBCO 30 Sec Start Volts DC.....49</p> <p style="padding-left: 20px;">Set 15 Min Start Volts DC.....49</p> <p style="padding-left: 20px;">Set 2 Hr Start Volts DC.....49</p> <p style="padding-left: 20px;">Set 24 Hr Start Volts DC.....48</p> <p style="padding-left: 20px;">Set Exercise Period Days.....49</p> <p style="padding-left: 20px;">Set Load Start Amps AC, .....48</p> <p style="padding-left: 20px;">Set Load Start Delay Min.....48</p> <p style="padding-left: 20px;">Set Load Stop Delay Min .....48</p> <p style="padding-left: 20px;">Set Maximum Run Time .....49</p> <p>Menu (13) – Gen Starting Details</p> <p style="padding-left: 20px;">Set Gen Warmup Seconds.....50</p> <p style="padding-left: 20px;">Set Max Cranking Seconds .....50</p>
---	--

# INDEX

Set Post Crank Seconds .....	50
Set Pre Crank Seconds .....	50
Set RY7 Function .....	49
Menu (14) - Auxiliary Relays	
Information Display .....	51
R 9 Hysteresis Volts DC .....	51
R10 Hysteresis Volts DC .....	51
Set Relay 9 Volts DC .....	51, 52
Menu (15) – Bulk Charge Trigger Timer	
Set Start Bulk Time .....	51
Menu (17) - Battery Selling	
Information Display .....	52
Set Battery Sell Volts DC .....	52
Set Max Sell Amps AC .....	52
Menu (18) - Grid Usage Timer	
Information Display .....	53
Set End Charge Time .....	53
Set Start Charge Time .....	53
Menu (19) - Information File Battery	
Information Display .....	53
Menu Access/Adjustment Buttons .....	34
Menu Heading Buttons .....	34
Menu Item Buttons .....	34
Set Points Buttons .....	34
Menu Buttons	
GEN Menu Button .....	34
ON/OFF Menu Button .....	34
Menu Heading Buttons .....	34
Menu Item Buttons .....	34
Menu Map	
Setup Menu .....	31
User Menu .....	30
Model Identification .....	8
Mounting .....	18
Multiple Inverters	
Series Stacked Operation	
240 VAC Input/Output Breaker .....	92

## N

NEC .....	14
NEC code .....	132
Neutral Terminals .....	93
Neutral To Ground Switching .....	14

## O

ON/OFF Menu Button .....	34
Operating Modes .....	58
Charger Mode .....	62
Energy Management Mode .....	89
Generator Support Mode .....	70
Inverter/Charger Mode .....	68
Low Battery Transfer (LBX) Mode .....	91
Peak Load Shaving Mode .....	90
Utility Back-up Mode .....	80
Utility Inter-active Mode .....	82
Options .....	127
Aux Relay Module .....	128
Gen Relay Module .....	128
RC8 Remote Control .....	128
SineWave Communications Adapter .....	127
SWCA .....	127
SWRC .....	127
Other Products .....	129
C12 Charge Controller .....	129
C40 Multi-Function Controller .....	129
Fuses And Disconnects .....	129
T240 Transformer .....	129
Over Current .....	11, 12
Over Current, Menu ( 5) .....	42
Over-Current Device .....	23
Overload .....	11
Overtemp .....	11

## P

Peak Load Shaving Mode .....	58
Personal Precautions .....	4
Power Consumption Of Common Appliances .....	130
Power On/Off .....	128
Press Reset Now For Defaults, Menu ( 3) .....	38
PSCB, Conduit Box .....	22, 128

## Q

Quick Install	
AC In Cabling .....	26
AC Out Cabling .....	26
DC Cabling .....	26
Mounting .....	26
Wrap Up .....	26

## R

R 9 Hysteresis Volts DC, Menu (14) .....	51
R10 Hysteresis Volts DC, Menu (14) .....	51
Radio Frequency Interference (RFI) .....	18
RC8	
Connection .....	14
Remote Control .....	128
Read Bulk/EQ timer, Menu ( 4) .....	40, 47
Read Frequency Hertz (Meter), Menu ( 4) .....	40
Read LBCO 30 Sec Start Volts DC, Menu (12) .....	49
Reference Tables And Graphs .....	130
Remote Control (SWRC) .....	127
Remote Port .....	15
Repair Required .....	133
Reset to Factory Defaults Button .....	32
Resistive Loads .....	108
Reverse Polarity .....	15, 23
RFI (Radio Frequency Interference) .....	18

## S

Safety Instructions	
General Precautions .....	3
Personal Precautions .....	4
Special Notices .....	3
Search Mode .....	59
SELL Mode .....	45, 52, 53, 64, 69, 83
Input Amps AC .....	39
Selling Excess Power .....	84
From DC Charging Source .....	84
Stored In The Batteries .....	85
Serial Number .....	7, 133
Series Stacked Operation	
240 VAC Input/Output Breaker .....	92
Set 15 Min Start Volts DC, Menu (12) .....	49
Set 2 Hr Start Volts DC, Menu (12) .....	49
Set 24 Hr Start Volts DC, Menu (12) .....	48
Set Absorption Time, Menu (10) .....	47
Set Battery Sell Volts DC, Menu (17) .....	52
Set Bulk Volts DC, Menu (10) .....	46, 47
Set Clock Hour, Menu ( 6) .....	43
Set Clock Minute, Menu ( 6) .....	43
Set Clock Second, Menu ( 6) .....	43
Set End Charge Time, Menu (18) .....	53
Set Equalize Time, Menu (10) .....	47
Set Exercise Period Days, Menu (12) .....	49
Set Float Volts DC, Menu (10) .....	47
Set Gen Warmup Seconds, Menu (13) .....	50
Set Generator, Menu ( 2) .....	36
Set Grid (AC1) Amps AC, Menu (11) .....	48
Set Grid Usage, Menu ( 9) .....	45
Set High Battery Cut Out VDC, Menu ( 9) .....	46
Set Input Lower Limit VAC .....	40, 70, 71, 72, 109, 111
Set Input Lower Limit VAC, Menu (11) .....	48
Set Input Upper Limit VAC .....	70, 72
Set Input Upper Limit VAC, Menu (11) .....	48
Set Inverter, Menu ( 1) .....	36
Set LBCO Delay, Menu ( 9) .....	46

<p>Set Load Start Amps AC, Menu (12).....48</p> <p>Set Load Start Delay Min, Menu (12).....48</p> <p>Set Load Stop Delay Min, Menu (12).....48</p> <p>Set Low Battery Cut In VDC, Menu ( 9).....46</p> <p>Set Low Battery Cut Out VDC.....49</p> <p>Set Low Battery Cut Out VDC, Menu ( 9) .....46</p> <p>Set Max Charge Amps .....62, 65</p> <p>Set Max Charge Amps AC, Menu (10) .....47</p> <p>Set Max Cranking Seconds, Menu (13).....50</p> <p>Set Max Sell Amps AC, Menu (17).....52</p> <p>Set Maximum Run Time, Menu (12).....49</p> <p>Set Points Buttons .....34</p> <p>Set Post Crank Seconds, Menu (13).....50</p> <p>Set Pre Crank Seconds, Menu (13).....50</p> <p>Set Relay 9 Volts DC, Menu (14).....51, 52</p> <p>Set RY7 Function, Menu (13).....49</p> <p>Set Search Spacing, Menu ( 9) .....46</p> <p>Set Search Watts, Menu ( 9).....46</p> <p>Set Start Bulk Time, Menu (15).....51</p> <p>Set Start Charge Time, Menu (18).....53</p> <p>Set Temp Comp, Menu (10).....47</p> <p>Setup Menu .....44</p> <p style="padding-left: 20px;">Menu Map.....31</p> <p>SineWave Communications Adapter (SWCA).....127</p> <p>SLT - Silent Mode.....45, 81</p> <p>Software Revision .....3, 5, 39, 93</p> <p>Special Notices.....3</p> <p>Specifications and Features .....117</p> <p>Stacking Inverters (120/240 VAC) .....71, 92</p> <p>Stacking Port .....15</p> <p>Start Charge Time.....53, 85, 86, 89, 90</p> <p>Start Quiet Time, Menu ( 7).....43</p> <p>Status LED.....11, 127</p> <p>SWCA .....29, 127</p> <p style="padding-left: 20px;">Remote Monitoring.....127</p> <p style="padding-left: 20px;">Remote Setup.....127</p> <p style="padding-left: 20px;">Remote Troubleshooting .....127</p> <p>SWRC.....127</p> <p style="padding-left: 20px;">Contrast.....32</p> <p>Controls And Indicators .....32</p> <p>Error LED Status Indicators</p> <p style="padding-left: 20px;">AC source wired to output .....42</p> <p style="padding-left: 20px;">External Error (stacked) .....42</p> <p style="padding-left: 20px;">Gen failed to start .....41, 79</p> <p style="padding-left: 20px;">Gen max run time error .....41, 78, 79</p> <p style="padding-left: 20px;">Gen speed error .....41, 79</p> <p style="padding-left: 20px;">Gen stopped due to V/F .....41, 79</p> <p style="padding-left: 20px;">Heatsink overtemp .....42</p> <p style="padding-left: 20px;">High Battery voltage .....41</p> <p style="padding-left: 20px;">Low Battery voltage .....40</p> <p style="padding-left: 20px;">Low Inverter voltage .....40</p> <p style="padding-left: 20px;">Over Current .....42</p> <p style="padding-left: 20px;">Transformer overtemp .....42</p> <p>GEN Menu Button.....34</p>	<p>LED Status Indicators.....33</p> <p style="padding-left: 20px;">AC1 In Good (Green) .....33</p> <p style="padding-left: 20px;">AC2 In Good (Green) .....33</p> <p style="padding-left: 20px;">Bulk (Yellow).....33</p> <p style="padding-left: 20px;">Error (red).....34, 40, 64</p> <p style="padding-left: 20px;">Float (Green).....34</p> <p style="padding-left: 20px;">Inverting (Yellow).....33</p> <p style="padding-left: 20px;">Line Tie (Yellow).....33, 86</p> <p style="padding-left: 20px;">Overcurrent (Red) .....34</p> <p>ON/OFF Menu Button.....34</p> <p>Remote Control.....32</p> <p>Reset to Factory Defaults Button.....32</p> <p><b>T</b></p> <p>T240 Transformer.....129</p> <p>Technical Information .....95</p> <p>TFB, Fuse Block.....22</p> <p>Time of Day Metering .....89, 90</p> <p>Time of Day, Menu ( 6).....43</p> <p>Transfer Time .....20, 68, 69, 80</p> <p>Transformer Overtemp, Menu ( 5).....42</p> <p><b>U</b></p> <p>Universal Motors ..... See Inductive Loads</p> <p>Unpacking.....6</p> <p>User Menu.....35</p> <p style="padding-left: 20px;">Menu Map.....30</p> <p>Using Multiple Inverters.....92</p> <p style="padding-left: 20px;">Parallel Stacked Operation.....93</p> <p>Utility Back-Up Applications .....45, 81</p> <p>Utility Back-Up Mode .....58, 89, 90, 91, 97</p> <p>Utility Inter-Active Mode.....58</p> <p><b>V</b></p> <p>Ventilation.....18</p> <p>Voltage Start Ready, Menu ( 2).....38</p> <p><b>W</b></p> <p>Warning Label .....21</p> <p>Warranty .....128</p> <p style="padding-left: 20px;">Not Covered.....17, 23</p> <p style="padding-left: 20px;">Shipping Address .....134</p> <p style="padding-left: 20px;">Warranty Registration And Repair .....133</p> <p>Well Pumps ..... See Inductive Loads</p> <p style="padding-left: 20px;">Inverter Surge ..... See Locked Rotor Amps</p> <p>Wiring</p> <p style="padding-left: 20px;">AC Terminal Block.....19</p> <p style="padding-left: 20px;">AC Wiring .....18</p> <p style="padding-left: 20px;">Installation Guidelines .....20</p> <p>Control</p> <p style="padding-left: 20px;">Fusing.....73, 128</p> <p>DC Wiring .....21</p> <p style="padding-left: 20px;">DC Disconnect .....22</p> <p style="padding-left: 20px;">DC Overcurrent Protection .....22</p>
--	--

INSIDE  
BACK  
COVER





5916 - 195th Street N.E., Arlington, WA 98223 Phone: (360) 435-8826 Fax: (360) 435-2229

*visit our website at: [www.traceengineering.com](http://www.traceengineering.com)*