

Sunny Boy

SWR 1800U

Technical Description

Issue 1.0

Grid Tied String Inverter for Photovoltaic Systems

Alteration Review

Document Number SB1800U	Issue and Alteration Review ¹⁾		Comments	Author
-11:EE0402	1.0	A	First issue	Homburg

¹⁾ A: Changes due to faulty documents or improvement of the documentation

B: Changes maintaining full or upward compatibility

C: Changes limiting or excluding compatibility

	Name	Date	Signature
Approved	Bremicker	02.07.2002	

Table of Contents

1	Introduction.....	4
2	System Description	5
2.1	String Technology	6
2.2	Diagnosis and Communication	8
2.3	Technical design of the Sunny Boy.....	9
2.3.1	Ambient Temperature.....	9
2.3.2	Sequential Control System.....	10
2.3.3	Stainless Steel Case	10
2.3.4	Islanding Protection.....	11
2.3.5	Grid Monitoring.....	12
2.3.6	Ground Fault Detector Interrupter (GFDI).....	13
3	System Monitoring and Diagnosis	14
3.1	Data Transmission via Powerline.....	14
3.2	Data Transmission with a Separate Data Cable	16
3.3	PV-System Management and Diagnosis.....	18
3.4	Measuring Channels and Messages.....	20
3.5	Measurement Precision	22
4	Technical Data	23
5	Appendix	31

1 Introduction

You have decided to use one of the most sophisticated devices and for the most advanced modular PV system technology by purchasing a *Sunny Boy*^{®1} String Inverter. SMA string technology has revolutionized parallel grid feeding. The SMA *Sunny Boy* String Inverters are the most successful photovoltaic String Inverters in Europe. They convince with their outstanding qualities concerning the efficiency and reliability and make the installation of a PV-system most simple and affordable. *Sunny Boy* String Inverters are the universal equipment for all applications – small or large scale PV-systems.

The *Sunny Boy* has complete on board islanding protection and meets safety operating standards and code requirements world-wide. In North America, the *Sunny Boy* meets the requirements of UL 1741. NEC 690 building code requirements for photovoltaic systems will be met with the internal ground fault detector interrupter (GFDI).

In Australia *Sunny Boys* are certified according to the “Australian Guidelines” and the regulations of the IEC950. In the United Kingdom *Sunny Boys* passed the tests in accordance with the “engineering recommendation G77”. The *Sunny Boys* comply with all regulations from the VDEW (Association of German Electricity Producers) for the supplementary grid feeding to the low voltage electricity grid of the utility. This contains the regulations concerning the “Independent Disconnection Device” known as MSD (Mains monitoring device with allocated Switching Devices) and the regulations of the DIN VDE 0126. Furthermore the *Sunny Boy* complies with the according standards and the low voltage regulations as certified in the CE declaration (see appendix).

¹ *Sunny Boy* is a registered Trademark of SMA Regelsysteme GmbH

2 System Description

The reduction of CO₂ emission and other pollution resulting from energy conversion is becoming more and more important. The direct conversion of solar radiation to electric energy (photovoltaics) will play a substantial role in this essential matter.

Supplementary grid feeding includes the conversion of the DC voltage from the PV-panel to grid compatible AC voltage with so-called "inverters" and the subsequent connection to the electricity grid in the house distribution.

Here the electricity from the PV-modules provides all consumers with electric power (household devices, lights etc.). In case that not enough energy is produced the additionally necessary energy is obtained from the grid. In case that there is a surplus of energy, this surplus is fed into the local grid and is therefore available for other consumers. This way every single kilowatt-hour is utilized and the electricity company's power systems are relieved. In the most simple case a PV-system therefore consists of two basic components: the PV-panel and the inverter.

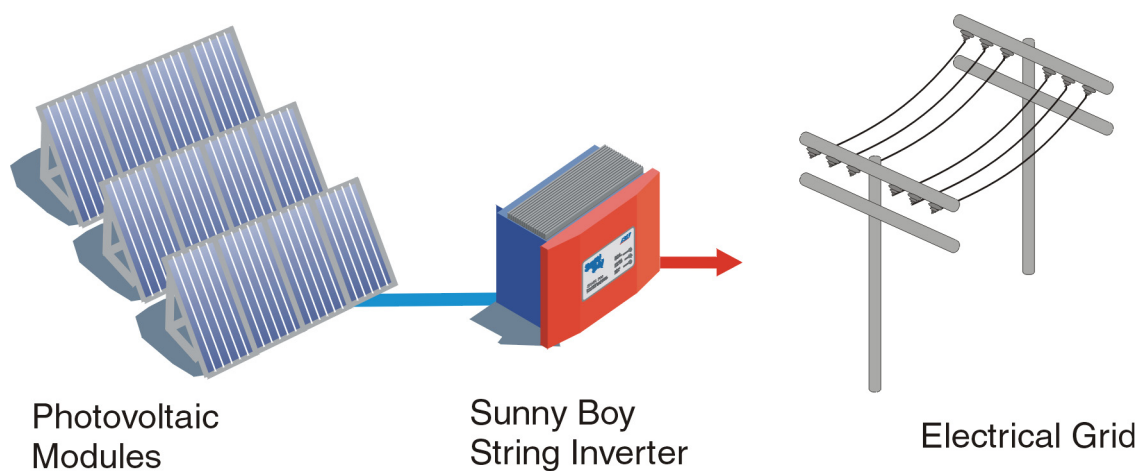

Fig. 2.1: Grid tied String Inverter application

2.1 String Technology

The experience with several thousand grid-connected PV-systems in Europe with an output range from one to several hundred kilowatts has shown that the costs for grid connecting and monitoring the PV-system add up to almost 50 % of the costs for the entire system. The reduction of these costs, especially the costs for the cabling on the DC side and the subsequent distribution on the AC side, was the reason for developing the String Technology from SMA. The *Sunny Boy* finally enabled the string technology to be the standard system design for PV-systems.

String technology means that a small number of PV-modules are connected in series to a "string", each string is then connected to a separate inverter which feeds the electricity of one string to the grid. Large PV-systems consist of a large number of single strings. The energy produced is collected directly on the AC side which results in the fact that the system design gets very simple and no extraordinary DC cabling is necessary anymore. String Technology allows MPP tracking for each small module group, thus improving system efficiency by 1 – 3%.

The most various system concepts can be realized with this strategy. A wide range of differently scaled inverters and peripheral components is available:

Sunny Boy Inverters:

- **Sunny Boy 700:**
The small model for small PV-systems with simple extension possibilities and configurable input voltage range
- **Sunny Boy 850:**
The output optimized inverter for PV-systems with 1 kWp
- **Sunny Boy 1100E:**
For PV plants with 1 kWp; supports a wider input voltage range
- **Sunny Boy 1700E:** For PV plants around 2.2 kWp / wide input voltage range

- **Sunny Boy 2000:**
The transformerless String Inverter with extended input voltage and increased efficiency, ideal for large PV-systems.
- **Sunny Boy 2500U:**
The powerful String Inverter with electric separation, ideal for large PV-systems.
- **Sunny Boy 3000:**
The powerful String Inverter with electric separation and optimum efficiency, ideal for large-scale plants.
- **Sunny Display**
Lid integrated LCD for all Sunny Boys, cyclic display of all relevant operating data
- **Sunny Data:**
The PC-program for the communication with your Sunny Boy inverters
- **Sunny Boy Control:**
The terminal for your PV-system for data acquisition and evaluation - for up to 50 Sunny Boys - communication via Powerline or RS232/RS485
- **Sunny Boy Control LIGHT:**
Terminal for PV systems with up to 20 Sunny Boys - communication via Powerline
- **Sunny Boy Control PLUS:**
The terminal for your PV-system for data acquisition and evaluation - for up to 50 Sunny Boys - communication via Powerline or RS232/RS485 - additional digital I/O channels for nearly any sensor type - continuous standalone data storage and remote access via modem etc.
- **Sunny Data Control:**
The PC-program for visualization of the data from your Sunny Boy Control

The Sunny Boy Family is the result of consistent development with SMA's experience in PV conversion with over 130 MW of total nominal inverter output power in over 90,000 units with nominal powers from 700 W up to 500 kW (update: 01/02).

2.2 Diagnosis and Communication

The modular PV system technology leads to a spread out distribution of the Sunny Boy String Inverters. A simple and fast function monitoring of the status and measured values for each single Sunny Boy is easy to achieve. The data is either displayed on the LCD of the Sunny Boy Control or is shown on the screen of a PC running the according SMA software. Two programs "Sunny Data" and "Sunny Data Control" are based on a comfortable Windows GUI and allow the user to process the data with other programs such as MS Excel®.

The data transmission is done via Powerline (see chapter 3.1). SMA supports the following monitoring strategies for Sunny Boy String Inverters:

- PC with software package Sunny Data for small and medium size PV-systems - also for Sunny Boy Control and Sunny Boy Control Light
- Sunny Boy Control as standalone controller for nearly any PV-system size
- PC with software package Sunny Data Control for enhanced operation together with the Sunny Boy Control

These monitoring concepts support the following features:

- Continuous acquisition of operation data of all connected String Inverters and their PV-panels
- Supervision of operating states and failure indication
- Spot value transmission from single Sunny Boys
- Identification of failures in the single strings
- Graphical representation of the data from single Sunny Boys or comparison of the data from several ones
- System management, transmission of operation parameters

2.3 Technical design of the Sunny Boy

The Sunny Boy inverter is based on a power unit that operates with a very high efficiency and optimal reliability. An IGBT H-bridge converts the voltage coming from the PV modules to a high frequency secondary circuit with 16 kHz. The voltage is then fed to the grid after being processed by a transformer.

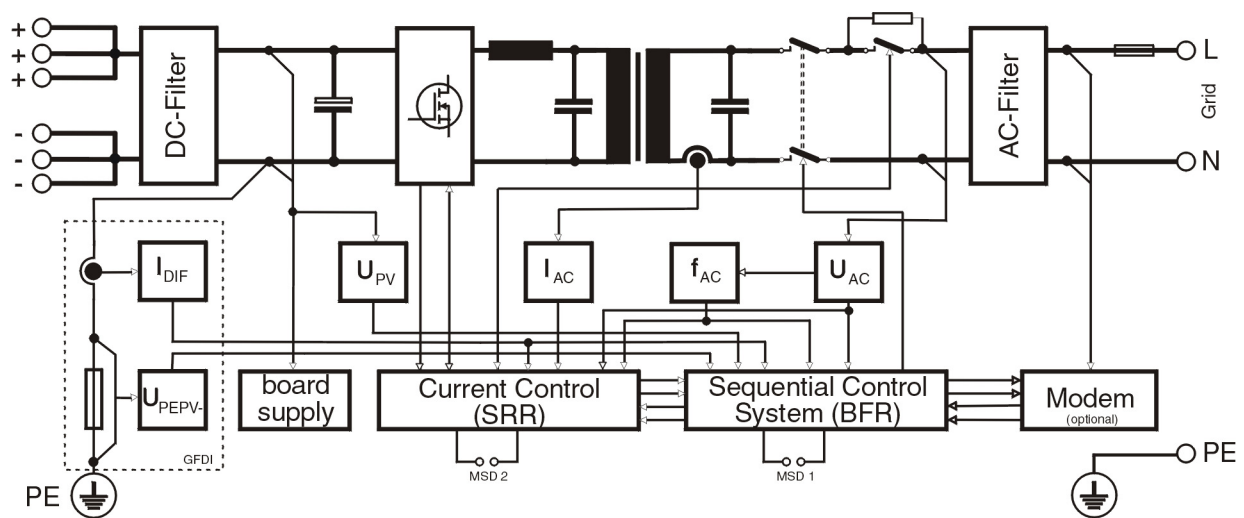

Fig. 2.2: Block circuit diagram of the Sunny Boy 1800U

The Sunny Boy 1800U is designed for strings with 11 to 16 standard modules connected in series.

A micro controller manages the current control which results in a perfectly sinus wave AC current with very low harmonic distortion. Both operation with a fixed voltage or with MPP tracking is possible.

2.3.1 Ambient Temperature

The heat sink of the Sunny Boy is necessary in order to let thermal energy dissipate. Once the heat sink gets too hot the Sunny Boy reduces the output energy accordingly but nevertheless keeps feeding to the grid.

2.3.2 Sequential Control System

The sequential control system also manages the communication with the system monitoring tools Sunny Data and Sunny Data Control. The Sunny Boy therefore is not only a simple standalone device - it can be part of one big PV-system that has one central control and monitoring facility.

2.3.3 Stainless Steel Case

The case of the Sunny Boy is made of stainless steel which protects the inverter from dust and water up to enclosure type NEMA 4X. The Sunny Boy can therefore be mounted nearly anywhere inside or outside the house with an ambient temperature range of -13 °F...140 °F (-25°C to +60°C). All applicable standards and regulations for personnel safety and EMI are complied with.

2.3.4 Islanding Protection

Islanding protection is an essential safety issue in order to make sure that nobody working on the grid is harmed. It is important to detect an "islanding" where the public grid is not up and the electricity consumers and producers are accidentally equal - resulting in the fact that the electricity circuits are on "full blow" even though the fuses are down.

The method of Sunny Boy islanding detection includes the active grid impedance measurement has been extensively tested and proven to exceed the requirements of UL1741. In the event of a utility outage, these active measurement results in an over/under frequency or voltage condition. The Sunny Boy then is disconnected from the grid. Two independent one-chip computers monitor the grid. Each of these computers constantly monitors the grid quality by checking the frequency, voltage and grid impedance. The redundant circuit and an automatic self test on each system startup ensure a reliable function of the grid disconnection. The value of the grid impedance is the sum of the impedance of the public grid and the cabling impedance of the house (i.e. cable of the house distribution to the connection point of the Sunny Boy). It is therefore important to avoid an unnecessary increase of the grid impedance due to the connection cable to the Sunny Boy. Otherwise the grid voltage is increased to non-permissible values while the Sunny Boy feeds to the grid.



NOTE: We recommend that you have a look at the connection wire between the Sunny Boy to the house distribution with respect to the impedance increase.

2.3.5 Grid Monitoring

Conditions that cause the Sunny Boy to be disconnected from the grid:

- Over/under AC-voltage
 - The grid voltage may be within a range of the requirements of UL1741. Once the grid voltage exceeds this range the Sunny Boy is disconnected from the grid within 0.1 s.
- Over/under grid frequency
 - The grid frequency may be within a range of +0.5 to -0.7 Hz of the nominal grid frequency while the voltage is within a range of -30 % and +15% of the nominal grid voltage V_{AC} - once the frequency goes beyond this range the Sunny Boy is disconnected from the grid within 0.1 s.
- Rate of change of frequency
 - Once the frequency changes drastically while it is feeding to the grid, the Sunny Boy disconnects within 0.2 s.

This new Sunny Boy disconnection concept provides maximal safety with nevertheless minimal necessary installation.

2.3.6 Ground Fault Detector Interrupter (GFDI)

The GFDI is supposed to interrupt the connection to ground of the PV panel in case a ground leakage current of 1 A is exceeded. This ground fault current is the result of a ground fault of the PV panel. The inverter then has to indicate this condition and disconnect from the grid. The inverter has to be reset manually, it cannot restart automatically.

In grid-feeding mode the ground current is continuously monitored by two independent systems, the sequential control system and the current control system. If the maximum current intensity is exceeded the inverter switches to “permanent disable”-“Earth-currentmax”. This is indicated by the red and yellow LEDs.

In addition the voltage between the ground and PV-minus is monitored. If the voltage exceeds the maximum value defined the failure “GFDI Fuse Open” is displayed and the inverter stops feeding to the grid. This failure is indicated by the red LED. The “GFDI Fuse Open” failure persists in case the GFDI fuse is defective.

3 System Monitoring and Diagnosis

The monitoring and control of PV-systems is essential for the optimal energy yield, the safety of your PV-system and the long life of your PV-components.

The Sunny Boy family inverters have various options for PV-system control and monitoring. This chapter will try to cover all different possibilities for the data transmission, the cabling circuits and how to eliminate and suppress any transmission failures.

3.1 Data Transmission via Powerline

Signal transmission between the Sunny Boy and the Sunny Boy Control or the PC is done with the grid connection via powerline. This requires a minimum of installation (see below). The Sunny Boy must be equipped with a powerline modem for data transmission. The PC must be equipped with the socket modem (SWR-COM). This is already integrated in the Sunny Boy Control, the specific controller for PV-systems. The PC or the Sunny Boy Control can be positioned anywhere within the in-house network as they acquire data directly from the AC circuit.

For trouble-free operation the Sunny Boys and the PC socket modem or the Sunny Boy Control must be connected to the same phase of the in-house network. If the communicating partners are connected to different phases the communication must be established with a so-called phase coupling device. The phase coupling device is available from SMA and must be installed by qualified personnel. It will make communication within the entire in-house network possible.

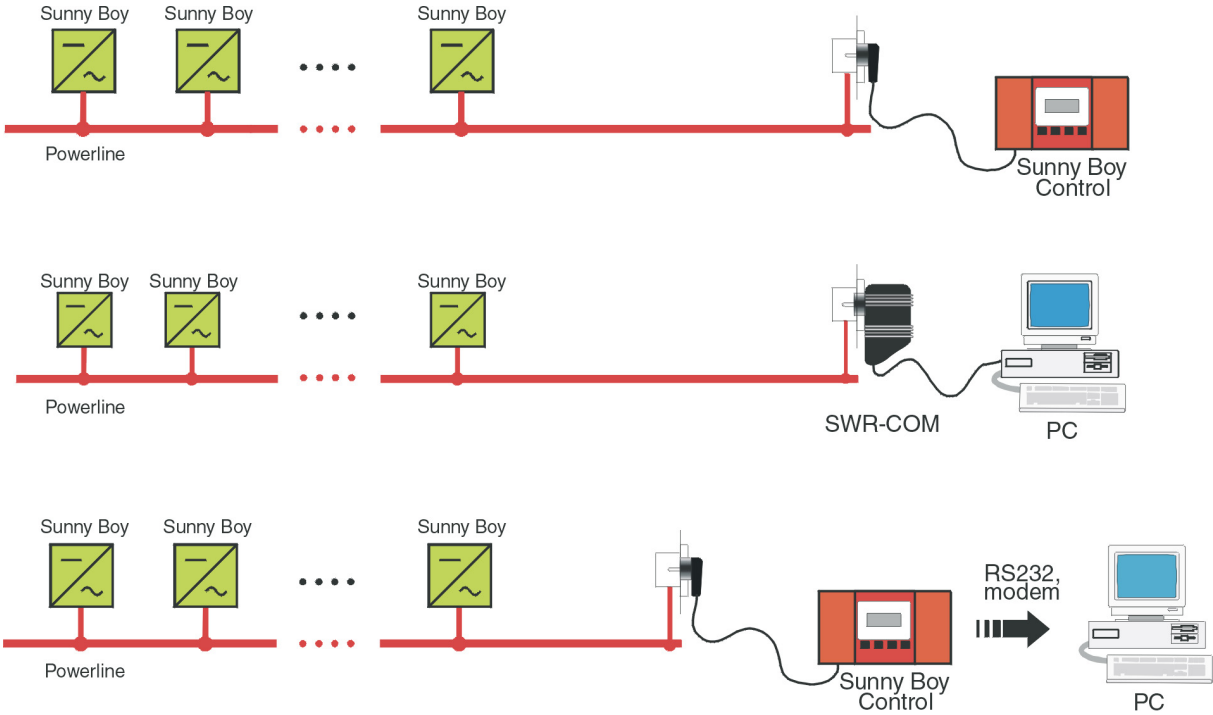

Fig. 3.1: Example of data transmission via Powerline

3.2 Data Transmission with a Separate Data Cable

Data transmission via Powerline is a reliable and affordable solution. In electrical grids which are strongly influenced by high-frequency disturbance such as those in industrial sites data transmission via Powerline may not be possible. Communication between the Sunny Boys and the Sunny Boy Control or the PC can then be done with a separate data cable.

RS232 communication

If only one Sunny Boy has to be connected to the PC the easiest way is direct coupling via an RS232 port. A maximum of 15 m is permissible between the PC and the Sunny Boy.

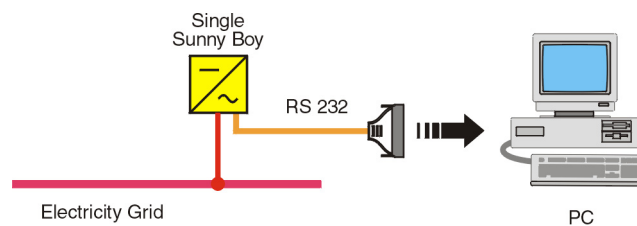

Fig. 3.2: Example for RS232 communication with a single Sunny Boy



NOTE: RS232 communication is only suitable for data transmission between a PC and one single Sunny Boy.



NOTE: RS232 communication with a Sunny Boy is only a reasonable solution with direct connection to the PC. If a Sunny Boy Control is used instead of the PC an RS485 connection is necessary. See section “RS485 communication” for details.

RS485 communication

In grids loaded with high interference several Sunny Boys can be connected to a PC or the Sunny Boy Control via RS485 and a separate data cable. Data cables of up to 1200 m are permissible.

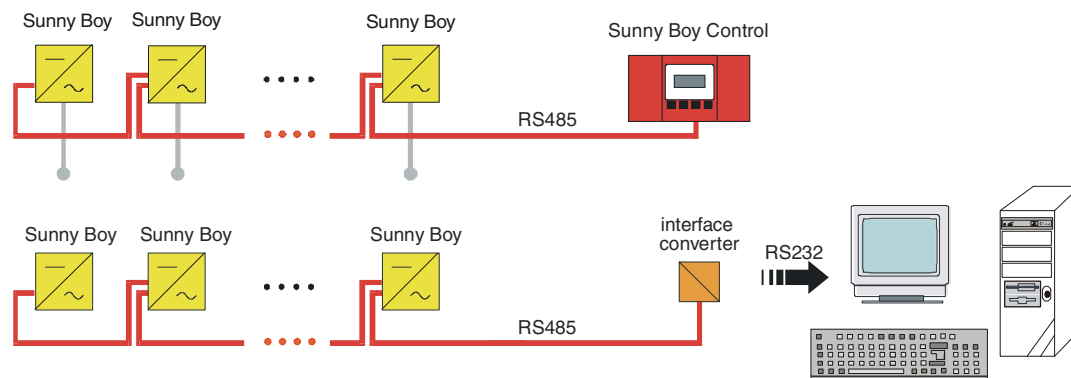

Fig. 3.3: Schematic layout of RS485 data transmission with several Sunny Boys

3.3 PV-System Management and Diagnosis

Sunny Data

Sunny Data is used in order to establish a communication between a PC and your Sunny Boys and process and evaluate the data from these.

Selected measurement channels can be displayed online. The data can be displayed manually or automatically. The data is stored on any available mass storage medium. Special functions allow the installer to modify the operating parameters of the Sunny Boy in order to improve the system performance. Details are available in the Sunny Data manual.

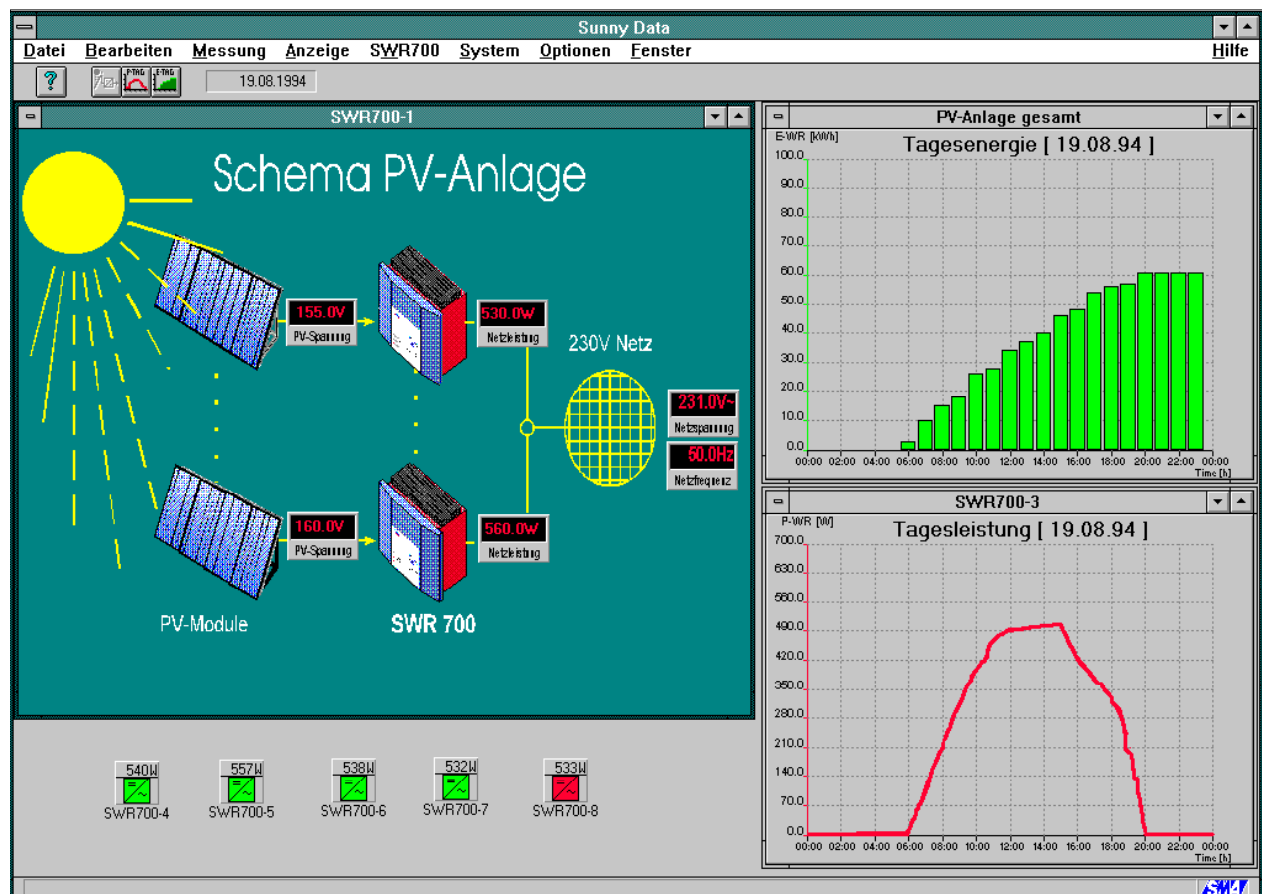

Fig. 3.4: Sunny Data user interface

Sunny Data Control

Large PV-systems are supervised and monitored with a Sunny Boy Control. The Sunny Boy Control handles up to 50 Sunny Boys and assists the commissioning of the PV-system. Additional features are remote diagnosis via modem, fax messages and more.

The data can be collected by a PC connected to the Sunny Boy Control. Sunny Data Control is the software that manages the PV-system and can display the data in nearly any desired way.

For details see the Sunny Data Control manual.

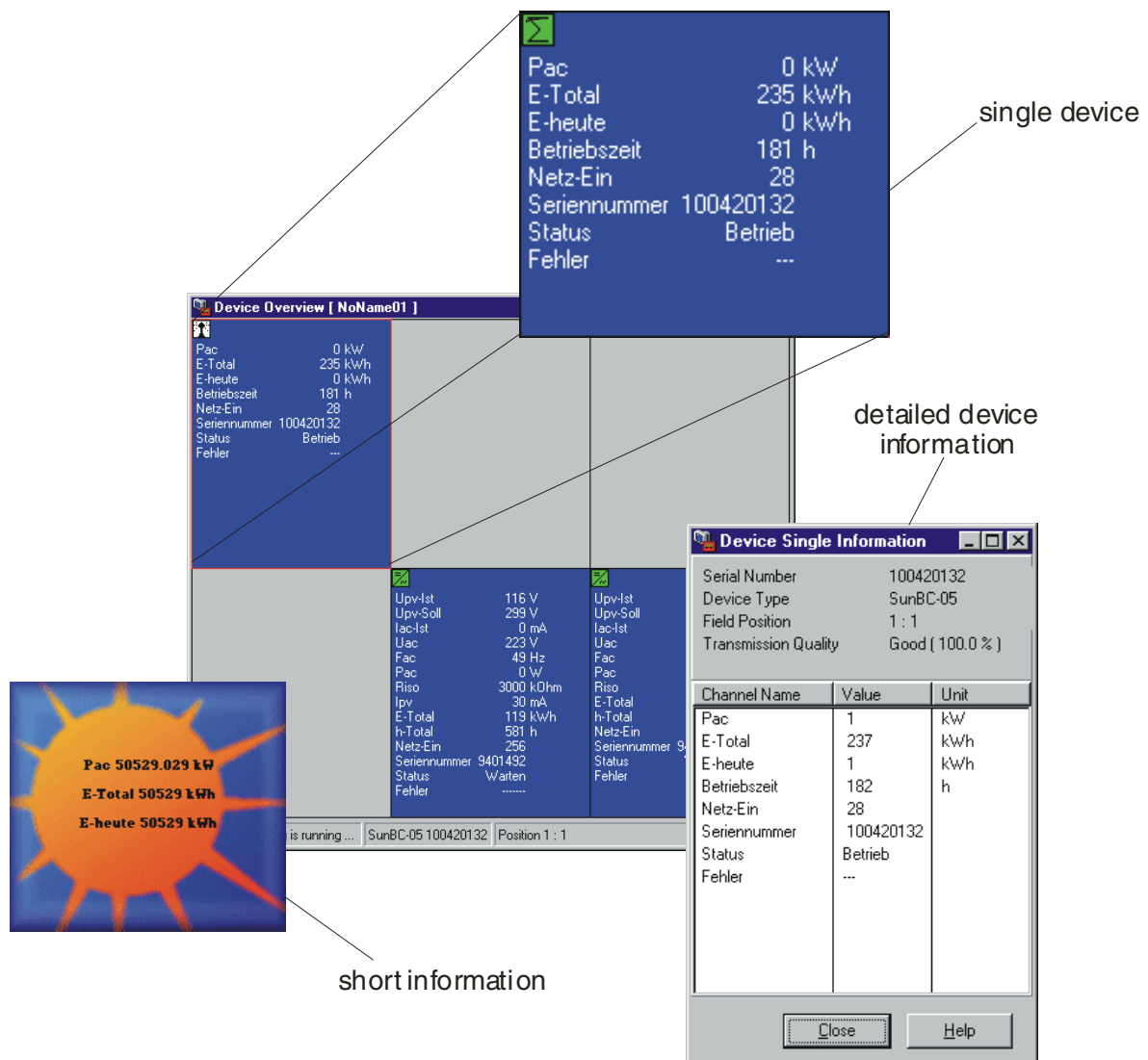

Fig. 3.5: Sunny Data Control user interface

3.4 Measuring Channels and Messages

The communication supports a number of measuring channels and messages from the Sunny Boy inverters.

The following abbreviations are used:

BFR	B etriebsföhrungsrechner (Sequential Control System)
SRR	S tromregelungsrechner (Current Control System)

Measuring Channels

Vpv	PV-input voltage
Vpv-Setpoint	PV-desired input voltage of the Vpv-control
Iac	current to the grid
Vac	grid voltage
Fac	grid frequency
Pac	power fed to grid
Zac	grid impedance
Vpv- _{PE}	PV-voltage to earth
Ipv	current from PV-panels
E-Total	energy yield
h-Total	total operation hours
Power On	total system start ups
Serial Number	<i>Sunny Boy</i> serial number
Mode	operating mode
Error	failure description for mode "disturbance"

Mode Messages

Stop	manual system stop
Offset	offset calibration of the electronics
Waiting	grid conditions are not fulfilled (yet)
Grid monitoring	checking grid (grid impedance)
MPP-Search	PV voltage is determined and set
MPP	<i>Sunny Boy</i> is in MPP mode
V-Const	<i>Sunny Boy</i> is in constant voltage MPP mode
Disturbance	failure

Error messages

F-Bfr-Srr	communication between micro-controllers is failing
F-EEPROM	EEPROM cannot be read or written on
F-EEPROM dBh	EEPROM cannot be read or written on
F-Fac-Bfr	BFR-frequency measurement - value out of tolerable range
F-Fac-Srr	SSR-frequency measurement - value out of tolerable range
F-dZac-Bfr	BFR-impedance measurement - value out of tolerable range
F-dZac-Srr	SSR-impedance measurement - value out of tolerable range
F-lmax	internal over current
F-Shut-Down	internal over current continuous
F-MSD-UAC	different values between BFR and SRR for grid voltage
F-MSD-FAC	different values between BFR and SRR for grid frequency
F-MSD-Meas	different values between BFR and SRR for dI, Fac, Vac or Zac
F-K1-Close	Relay test failed
F-K1-Open	Relay test failed
F-EarthCurMax-S	SRR-earth current between PV and GND is out of tolerable range
F-EarthCurMax-B	BFR-earth current between PV and GND is out of tolerable range
F-MSD-ZAC	different values between BFR and SRR for grid impedance
F-Offset	Offset check for grid voltage failed
F-MSD-Timeout	BFR or SSR controller failure
F-Vac-Bfr	BFR-grid voltage measurement - value out of tolerable range
F-Vac-Srr	SSR-grid voltage measurement - value out of tolerable range
F-VpvMax	PV input voltage out of tolerable range
F-Zac-Bfr	BFR-grid impedance measurement - value out of tolerable range
F-Zac-Srr	SSR-grid impedance measurement - value out of tolerable range
F-Watchdog	Watchdog for operation control triggered
F-ROM	failure of read only memory test

3.5 Measurement Precision

Any kind of measurement always depends on the accuracy. The reproducibility of the measurement values is conceived for an ambient temperature of 77 °F (25 °C). Other temperatures must be evaluated with respect to the inaccuracy resulting from these different temperatures.

	Unit	Range	Resolution		Maximal failure $\vartheta_U=+77^\circ\text{F}$
			Display	Measurement	
Input voltage	V_{PV} [V]	0...650 V	1 V	1,12 V	$\pm 2\%$
Input current	I_{PV} [mA]	0...12000 mA	1 mA	12 mA	$\pm 4\%$
grid voltage	V_{AC} [V]	90...150 V	1 V	0,3 V	$\pm 1\%$
grid current	I_{AC} [mA]	0...15800 mA	1 mA	30 mA	$\pm 2\%$
grid frequency	f_{AC} [Hz]	55.5...64.5 Hz	0.01 Hz	0.01 Hz	$\pm 0.1\%$
output power	P_{AC} [W]	0...2500 W	1 W	1 W	$\pm 3\%$
energy yield	E [kWh]	0...4,29* 10 ⁹ Wmin	1 Wmin	20 Wmin	$\pm 3\%$
operating hours	H [h]	0...4.29*10 ⁹ s	1 s	0.67 μs	$\pm 0.1\%$

Table 3.1: Measurement accuracy of the *Sunny Boy*

4 Technical Data

Input (PV panel)

Maximum open circuit voltage of the PV panel



WARNING: It is essential to comply with the respective input voltage range which varies depending on the type and number of PV modules used.



WARNING: The maximum open circuit voltage of the PV panel may not exceed the specified maximum input voltage of the Sunny Boy.

The open circuit voltage of the PV panel depends on the temperature of its cells and on the respective solar radiation. The highest open circuit voltage of the PV panel occurs when the temperature of the cells is at its lowest point. Therefore it has to take into account the lowest possible ambient temperature of the PV panel when planning the PV-system. Based on this temperature and knowing the type of PV modules used you can then determine the maximum open circuit voltage of the PV panel. You can enter these data into our EXCEL[®] tool “GenAu“ and check whether the maximum admissible input voltage of the Sunny Boy is not exceeded under any possible operating conditions. You will find this tool in the Internet for download at:

<http://www.sma.de/ftp/energietechnik/sunnyboy/GenAu/GenAu.exe>



WARNING: The MPP-voltage of the connected PV-modules may not get below the specified range at +160°F ($U_{MPP +160\text{ °F}} > \text{min. input voltage range}$).



NOTE: The Sunny Boy can tolerate a current higher than the specified current as long as the voltage is within the specified range.

Minimum MPP voltage of the PV panel

Often a fixed lower MPP voltage limit of the inverter is not useful when the cells of the PV panel have very high temperatures. This means the MPP voltage of the PV panel decreases and the inverter cannot feed the maximum power from the PV panel to the low-voltage grid. The inverter remains at the lower limit of input voltage and cannot follow the MPP of the PV panel. Therefore the Sunny Boy has a flexible MPP voltage range.

There is a fixed ratio between the minimum MPP voltage V_{MPPmin} the Sunny Boy loads onto the PV panel and the grid voltage V_{AC} as shown in Fig. 4.1

Depending on the current grid voltage the minimum DC voltage is assessed and fixed. This flexible MPP voltage range lets the user make optimum use of the specific device characteristics while the energy yield is increased.

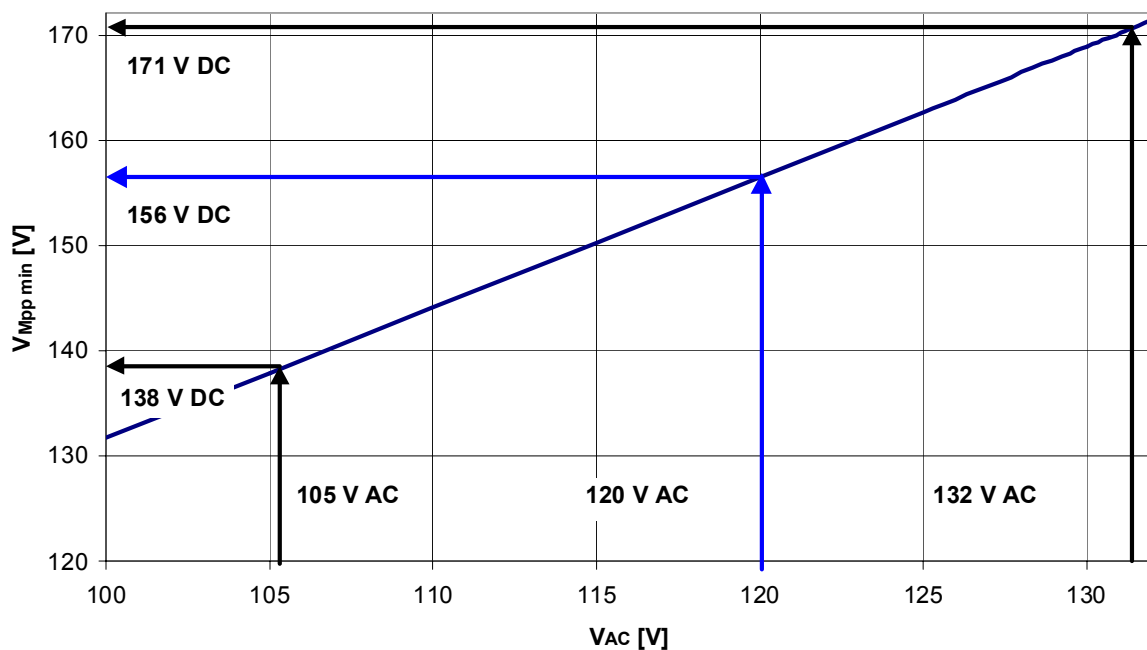

Fig. 4.1: Minimum MPP voltage as a function of grid voltage

Input values of the Sunny Boy (DC side)

Input voltage, MPP range (depending on V_{AC}):	V_{PV}	139 V* - 400 V DC
Max. open circuit voltage (under all conditions):	V_{PVOC}	≤ 400 V DC
Max. input current:	I_{PV}	12 A DC
Max. DC power:	P_{PV}	1960 W DC
Recommended PV-generator power:	up to	2200 W _p
Voltage ripple:	V_{PP}	< 10%
All-pole disconnection on DC side:		optional external DC-breaker
Pole confusion protection:		short circuit diode
Ground fault protection:		ground fault detection
		($I_{Dif} > 1000$ mA)

* @ V_{ACnom}

Output values of the Sunny Boy (utility side)

Nominal output power:	P_{ACnom}	1650 W AC
Maximum output power:	P_{ACmax}	1800 W AC
Operating range, grid voltage:	V_{AC}	106 - 132 V AC
Operating range, grid frequency:	f_{AC}	59.3 – 60.5 Hz
Total Harmonic Distortion (THD):	THD_{IAC}	< 4 % (with $K_{Vgrid} < 2 \%$, $P_{AC} > 0.5 P_{ACnom}$)
Phase shift (ref. fundamental)	φ	0°
Utility monitoring:		
- Islanding protection:	V_{AC} ; f_{AC}	in accordance with UL 1741
- Ground Fault Protection:	I_{DIF}	in accordance with UL1741
All pole disconnection utility:		independent disconnection (MSD), redundant design (double)
Short circuit protection:		current controlled
Oversvoltage classification:		III
Testing voltage (50 Hz):		2.88 kV (1 s)
Testing voltage for surge (1.2/50 μ s):		4 kV (serial interface 6 kV)

External Interfaces

Data transmission via Powerline:	optional
Data transmission via separate cable:	optional; electrically separated RS232 / RS485

Power Consumption

Internal consumption during operation:	< 3 W
Internal consumption during stand-by:	< 0.1 W

Efficiency

Max. Efficiency:	η_{\max} > 93.5 %
------------------	------------------------

Ambient Conditions

Tolerable ambient temperature:	-13 °F...140 °F (-25 °C ... +60 °C)
Rel. humidity:	0 ... 100 %, class 3K6

Size & Weight

Enclosure type:	NEMA 4X
Size (w x h x d):	17.08 x 11.61 x 8.42 inch (434 x 295 x 214 mm)
Weight:	approx. 60 lb. (27 kg)

Certifications:

EMI:	in compliance with FCC regulations, DIN EN 50081, part 1 (EN 55014, EN 60555 part 2, EN 55011 group 1, class B) DIN EN 50082, part 1
Utility interaction:	in compliance with UL1741, EN 61000-3-2
Utility monitoring:	in compliance with UL1741, optional: MSD (VDEW; E DIN VDE 0126 (10.97))
Low voltage regulation:	DIN EN 50178 (4.98) (VDE 0160) DIN EN 60146 part 1-1 (3.94) (VDE 0558 part 11)

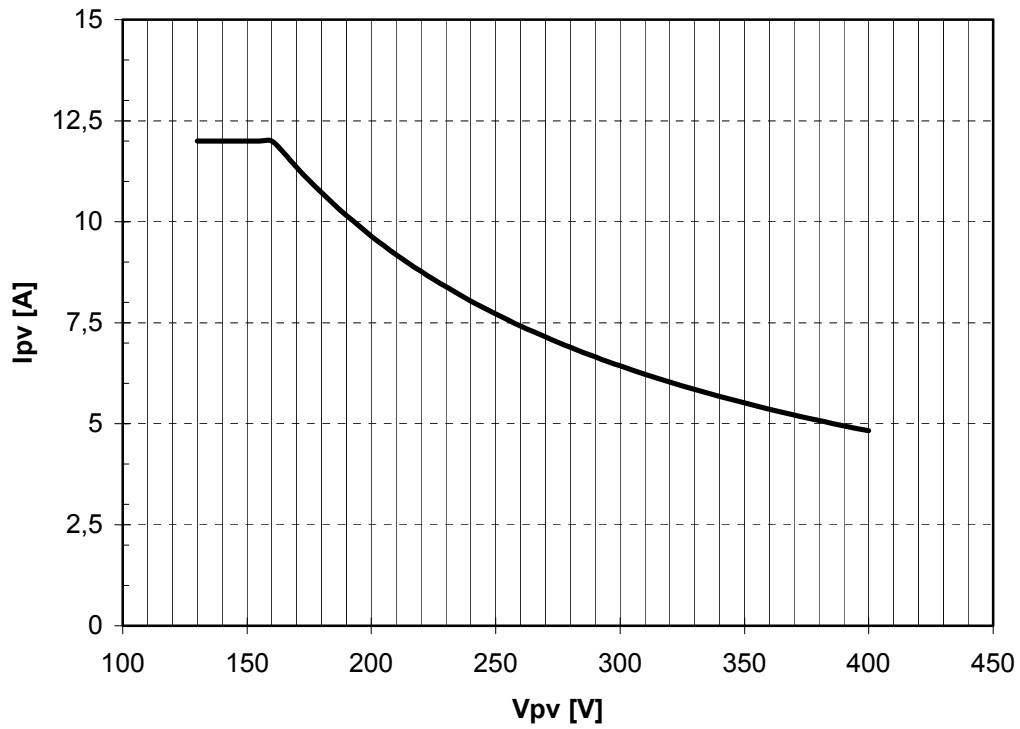

Fig. 4.2: Maximum Input Current of the Sunny Boy 1800U

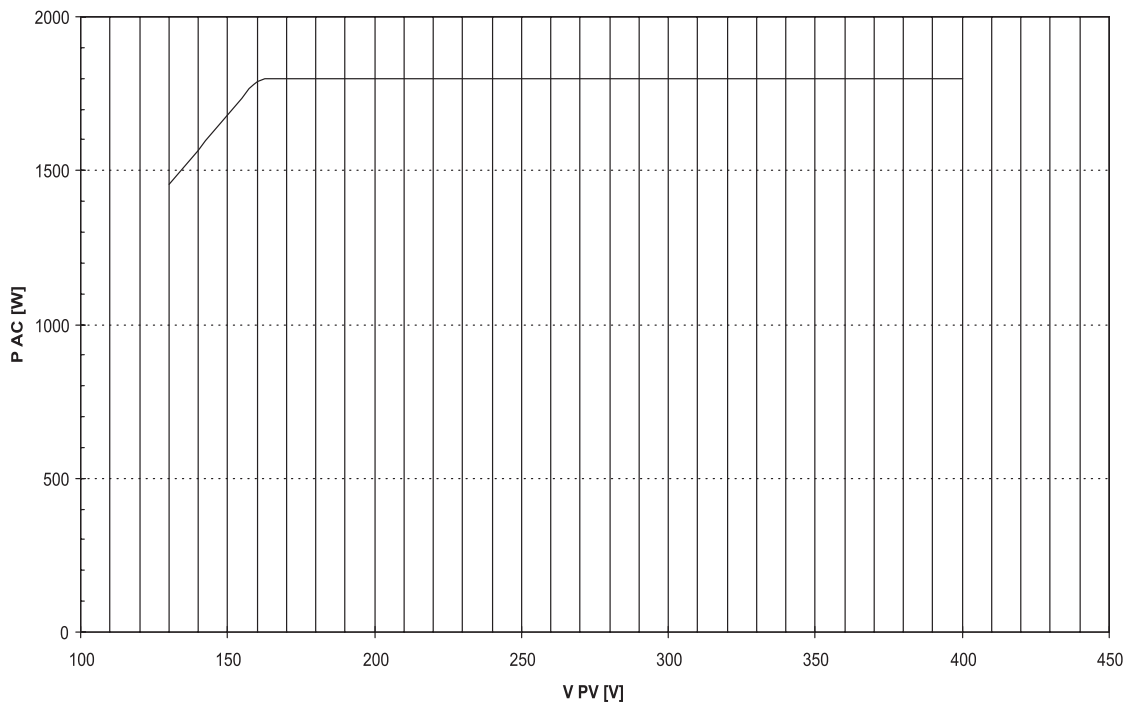

Fig. 4.3: Output Power of the Sunny Boy 1800U

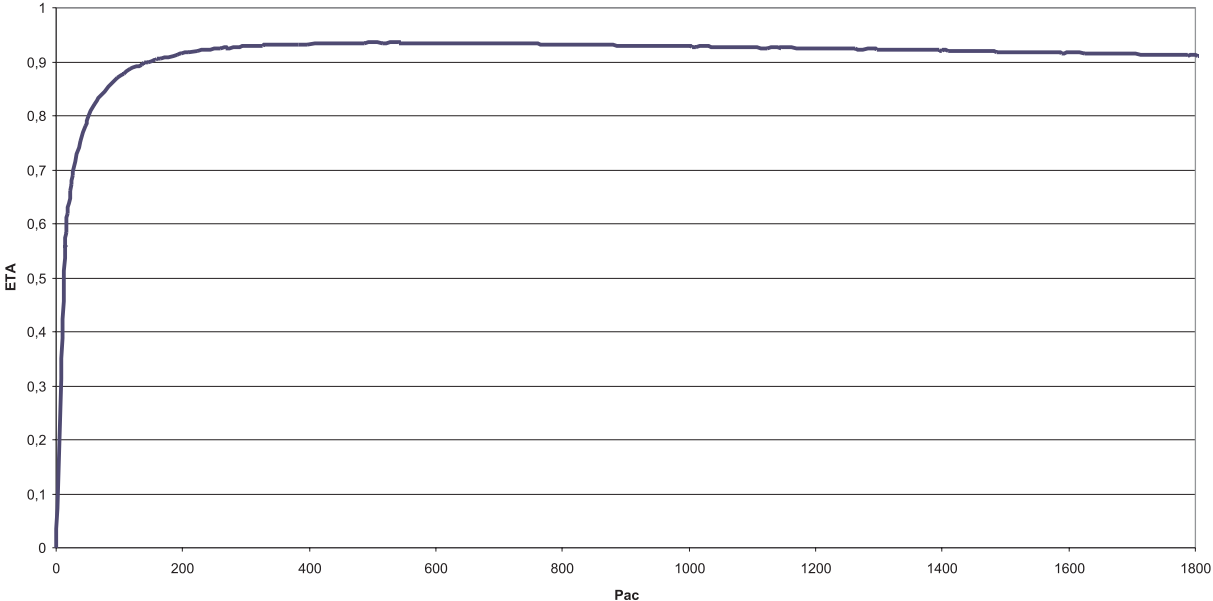

Fig. 4.4: Efficiency of the Sunny Boy 1800U

Parameter List Sunny Boy 1800U

All parameters are transmitted to Sunny Data or to the Sunny Boy Control when the Sunny Boy is configured. The following table shows the available parameters:

No.	Name	Unit	Range		Default	Change by ...
			from ...	to...		
1	SMA-SN	-				Fixed
2	Vpv-Start	V	150	400	190	Installer
3	T-Start	S	5	300	300	Installer
5	T-Stop	S	1	1800	2	Installer
6	V-Const Setval	V	150	400	400	Installer
	Plimit	W			1800	Fixed
23	Test current Zac	mA	0	15000	8000	Installer
28	Vac-Min	V	90	150	107	Installer
29	Vac-Max	V	90	150	130	Installer
30	Fac-delta-	Hz	0	4,5	0,69	Installer
31	Fac-delta+	Hz	0	4,5	0,49	Installer
	dFacmax	Hz/s	0.005	4.0	0.5	Installer
32	Zac-Max	mOhm	0	20000	20000	Installer
33	dZac	mOhm	0	20000	20000	Installer
43	Hardware-BFS	Version				Fixed
44	Software-BFR	Version				Fixed
45	Software-SRR	Version				Fixed
68	Operating mode				MPP-operation	Installer
69	Memory function				no function	Installer
	Default				USA 60Hz	Installer
	Storage				permanent	Installer

Table 4.2: Parameter list Sunny Boy 1800U

5 Appendix

Certificate for Sunny Boy 1800U

333 Pfingsten Road
Northbrook, Illinois 80062-2096
United States Country Code (1)
(847) 272-8800
FAX No. (847) 272-8129
<http://www.ul.com>



NOTICE OF AUTHORIZATION TO APPLY THE UL MARK

Northbrook Office

May 10, 2002

Sma Regelsysteme GmbH
Attn: Mr. Frank Greizer
Hannoversche Str 1-5
34266 Niestetal Germany

Our Reference: File E210376, Project 02MK03815

Subject: 1 - UL 1741 investigation of SWR-1800 inverter.
2 - UL 60950 investigation of RS-232, RS-485 boards for use with SWR series.

Dear Mr. Greizer:

We have completed our engineering investigation under the above project number and find the products comply with the applicable requirements.

This letter temporarily supplements the UL Follow-Up Services Inspection Procedure and serves as authorization to apply the UL Listing Mark, only at the factory under UL's Follow-Up Service Program, to the above products, which are constructed as described below:

Similar to products covered in the UL Follow-Up Services Inspection Procedure, File E210376, Volume 1, Section 1.

To provide the manufacturer with the intended authorization to use the UL Mark, the addressee must send a copy of this Notice and all attached material to each manufacturing location as currently authorized in the appropriate UL File Procedure.

This authorization is effective for 90 days only from the date of this Notice and only for products at the indicated manufacturing locations. Records covering the product are now being prepared and will be sent to the indicated manufacturing locations in the near future. Please note that Follow-Up Services Procedures are sent to the manufacturers only unless the Applicant specifically requests this document.

Products produced, which bear the UL Mark, shall be identical to those evaluated by UL and found to comply with UL's requirements. If changes in construction are discovered, authorization to use the UL Mark may be withdrawn and products that bear the UL Mark may have to be revised (in the field or at the manufacturer's facility) to bring them into compliance with UL's requirements.

Respectfully,

John W Carr (Ext. 41760)
Associate Project Engineer
Conformity Assessment Services - 3013MNBK
E-mail: John.W.Carr@us.ul.com

Reviewed by:

Timothy P. Zgonena (Ext. 43051)
Staff Engineer
Conformity Assessment Services - 3013MNBK
E-mail: Timothy.P.Zgonena@us.ul.com

A not-for-profit organization
dedicated to public safety and
committed to quality service

Information about SMA

Further literature about the Sunny Boy inverter family²:

- User Manual Sunny Boy 700/850
- User Manual Sunny Boy 1100E
- User Manual Sunny Boy 1700E
- User Manual Sunny Boy 2000
- User Manual Sunny Boy 2500U
- User Manual Sunny Boy 3000
- User Manual Sunny Data
- User Manual Sunny Data Control
- User Manual Sunny Boy Control
- User Manual SWR-COM Socket Powerline Modem
- Sunny Boy Info (periodical newsletter with up-to-date information)
- SMA CD (products, technical documentation, driver)
- Manual "Improved Powerline communication with the Sunny Boy Family"

Sunny Boy in the Internet:

All documentation and software concerning the Sunny Boy products is available on the Internet - <http://www.sma.de/>

Our Sunny Boy Homepage is updated daily and offers:

- the newest information concerning the Sunny Boy inverter family
- the newest software
- help concerning problems with your PV-system
- and of course all you might want to know about SMA Regelsysteme

² This literature can be ordered from SMA for a small fee - most of this although is available free of charge for download from WWW.SMA.DE .

Those who want to know more about SMA Regelsysteme GmbH and its products are very welcome to visit us on our homepage.

SMA in the USA:

- Address: **SMA America Inc.**
20830 Red Dog Road
Grass Valley, CA 95945
- Telephone: 530.273.4895
- Telefax: 530.274.7271
- eMail: info@sma-america.com
- Internet: <http://www.sma-america.com>

SMA in Europe:

- Address: **SMA Regelsysteme GmbH**
Hannoversche Straße 1-5
D-34266 Niestetal
- Telephone: 0049561/9522-0 (operator)
0049561/9522-499 (Sunny Boy Service)
- Fax: 0049561/9522-100 (main fax)
0049561/9522-4699 (Sunny Boy Service)
- E-mail: <mailto:info@sma.de>
- Internet: <http://www.sma.de>

Appendix: drilling template