

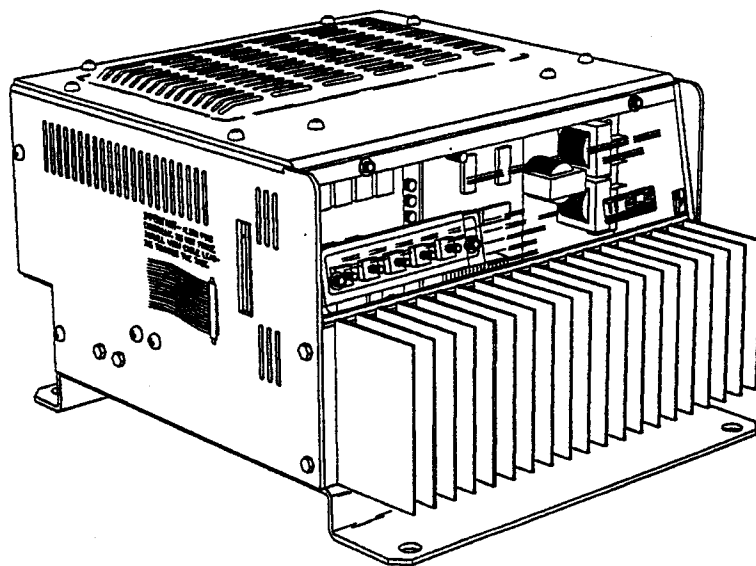

Owner's Manual

**2012
Series
Inverters**



Trace Engineering
5916 - 195th Street N.E.
Arlington, WA 98223
Phone: (360) 435-8826
Fax: (360) 435-2229

**2 Stage Charger
External Terminal Block**

visit our website at: www.traceengineering.com

971-9901-03-01 Rev. A

TABLE OF CONTENTS

Operation

Startup	1
Protection Circuitry	1
Indicator Lamps	1
Search Mode Control	2

Standby Option

Overview	3
Using the Programing Switches	4
Battery Charger	6

Automatic Transfer Modes

AC Transfer	7
Battery Transfer	8
Transfer Switching Speed	9

Digital Voltmeter Option

Digital Voltmeter Fuctions	10
Installation	10

Installation

Environment	11
AC Connections	12
Battery Connections	13
Estimating Battery Requirements	14

Applications

Resistive Loads	16
Inductive Loads	16
Problem Loads	17
Medical Equipment	18

Technical Information

Specifications19
Options20
Design Goals21

Performance Graphs

Power vs. Time24
Power vs. Efficiency24
Maximum Regulated Power vs. Battery Voltage26
Maximum Loads vs. Temperature27
Max Charge Rate vs. Time28
Battery Charge Rates vs. Peak Input Voltage29

Installation Diagrams

Installation Using Plugs30
Standby Inverter with Single AC Panel31
Standby Inverter with Two AC Panels32
Inverter with Two AC Panels and External Relay33
External Transfer Relay Details34

Warranty Information

Limited Warrantyi
Warranty Procedureii
Registration Formiii

OPERATION

Startup

When first connected to batteries, the inverter will be in the off state. Whenever the batteries are connected, the momentary power switch must be pressed twice to turn the inverter on. Subsequently pressing the on/off switch alternately turns the inverter on and off. An amber LED indicator lamp will light while the power switch is pressed to acknowledge the unit has changed states.

Protection Circuitry

The inverter will automatically restart itself from the following overload conditions: low battery, high battery, shorted output, over current, over temperature.

The inverter will turn itself off and need to be manually restarted under the following conditions: (1) if it is put to the ultimate test and has its AC output connected to public power; (2) if an attempt is made to start a very large motor; (3) if it encounters a load large enough to enable the protection circuit and reduce the output wave form for approximately 15 seconds (a prolonged short circuit).

Indicator Lamps

There are 5 LED indicator lamps on the Series 2000 units. The standby option adds one more. The "On/Off" and the standby option's "CHARGING" LED's are amber. The rest are red.

- **On/Off** - This LED lights momentarily when the power switch is pressed to acknowledge that the inverter has either turned on or off depending on its previous state. When batteries are first connected it must be pressed twice. With the standby model the ON/OFF switch also controls the battery charger function.
- **Over Load** - This LED lights when the load being run demands more current than the inverter can safely supply. If the lamp is on while a load is running, it implies a reduced output voltage. Since the protection circuit is temperature compensated, a large load that runs satisfactorily when the unit is cold may begin to trip the protection circuit and light the overload lamp when the inverter is warm. If an overload condition exists for more than 20 to 30 seconds, the inverter will turn itself off and need to be manually reset. The on/off button will need to be pushed twice - the first time to clear the overload condition, the second time to turn the unit on.

- **Over Temperature** - If the temperature of either the power transformer or the heat sink rises above its designed operating limits, this LED will light until the inverter has cooled sufficiently to restart.
- **High Battery** - If battery voltage rises above 15.2 VDC the inverter shuts down and lights this LED. When the voltage has dropped to 14.8 VDC it restarts.
- **Low Battery** - In order to protect itself, the inverter shuts down and lights this LED when battery voltage falls below 9 VDC for more than 3 seconds. The unit resets itself after the voltage rises above 9 VDC. Note: There is an adjustable LBCO option available for battery protection.
- **Charging** (standby models only) - This LED indicates that the unit is in the battery charger mode.

Search Mode Control

The Series 2000 inverters feature an adjustable search mode circuit. It minimizes power drain by reducing the inverter's output to small test pulses when there is nothing being run. These pulses are used to detect the presence of a load. The sensitivity of the detection threshold is adjustable. The factory setting is for the most sensitive position of 1 watt. There are conditions when this is not desirable. For example: household wiring may have enough capacitance to appear larger than 1 watt; when the inverter is used as an uninterrupted power supply the search mode should be defeated.

In the search mode the inverter makes a ticking sound. At full output voltage it makes a steady humming sound.

Sensitivity is adjusted by DIP switch bank #1. It is the 4 switch bank located 1.5 inches up and 3 inches from the right hand side of the circuit board. *Table 1* gives the switch settings and corresponding thresholds.

Refer to *Figure 1* for the location of switch bank #1. Switch bank #1 is mounted such that pressing the left side of the individual rocker switches turns them on.

Use the wooden stick supplied to change switch settings.

Important - BEFORE SETTING ANY INTERNAL SWITCHES DISCONNECT THE INVERTER FROM THE BATTERY. Touch the heat sink to discharge any static charge in your body. Remove the two No. 6 screws from the lexan cover and set it to the side carefully.

Table 1 - Search Mode Sensitivity

		Switch Bank #1			
		1	2	3	4
Threshold in Watts	1	ON	ON	ON	ON
	2	ON	ON	off	off
	6	ON	off	ON	off
	16	ON	off	off	ON
	40	ON	off	off	off
	Defeated	off	---	---	---
		1	2	3	4
		Switch Number			

Standby Option

Overview

The standby option adds an internal battery charger and automatic transfer relay. This allows the unit to operate as either a battery charger or inverter, but not both at the same time. An external source of AC power (eg, shore power or generator) must be supplied to the inverter in order to allow it to operate as battery charger. When the unit is operating as a charger, its AC output is powered by the external source.

30 Amps is the maximum power that can be handled by the inverter's internal wiring and transfer relay. During heavy charging up to 20 amps may be consumed by the charger leaving 10 amps available for external loads. By reducing the charge rate, more current can be made available for these loads.

Units with the standby option have five momentary switches on the front cover. Four of these are for operating the Digital Voltmeter option. If your unit is not equipped with the DVM option it may be added later.

Two banks of DIP switches control battery charger and transfer characteristics.

Using the Programing Switches

Overview

A four position bank of DIP switches is used to control the sensitivity of the search mode circuit - **Switch Bank #1**. See the section "Search Mode Control" for settings.

The optional charger adds two additional banks of DIP switches - **Switch Bank #2** and **Switch Bank #3**.

The location of the switch banks is given in *Figure 1*.

Important - BEFORE SETTING ANY INTERNAL SWITCHES DISCONNECT THE INVERTER FROM THE BATTERY. Touch the heat sink to discharge any static charge in your body. Remove the two No. 6 screws from the lexan cover and set it to the side carefully.

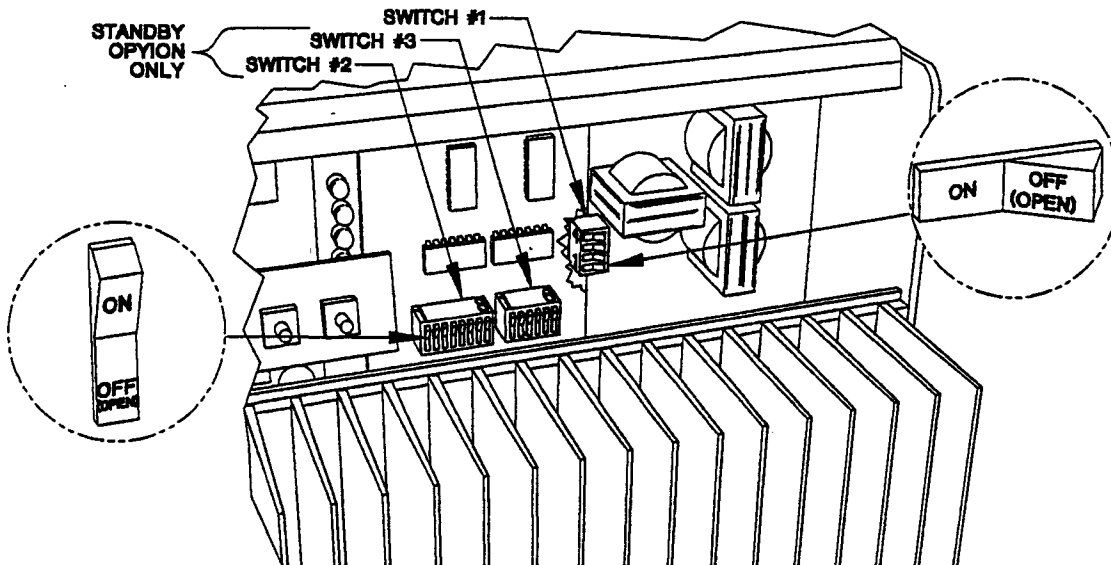

Figure 1, Switch Bank Location

Switch Bank #1

This bank of switches is oriented such that the first position is on the bottom. In order to turn a position "on", the left side of the switch is depressed.

Switch Bank #2

This is an eight switch bank that controls the transfer mode, battery charger On/Off, charge rate and charge voltage. See the section on the "Battery Charger" for details.

The following is a description of the function of each switch of bank #2:

- **Switch 1** - When set "ON" "Battery Transfer Mode" is enabled. When set "off" "AC Transfer Mode" is enabled. See section on "Standby Option" for details.
- **SwitchPosition 2** - When set "on" the battery charger is enabled. When set "off" the battery charger is defeated.
- **Switches 3, 4 and 5** - These are used in combination to set the battery charger's maximum charge voltage.
- **Switches 6, 7 and 8** - These are used in combination to set the battery charger's maximum charge current.

The first position is on the left. To turn a position "On", the top of the rocker is depressed.

Switch Bank #3

This six switch bank is used only when the "Battery Transfer Mode" is selected. It controls the low and high battery transfer points. See the sub heading "Battery Transfer" of the "Standby Option" section a complete operation description and switch position details.

The first position is on the left. To turn a position "on", the top of the rocker is depressed.

Battery charger

The battery charger is a constant current, voltage limited design. This means that it will try to charge at the charge rate setting until the maximum battery voltage setting is reached. Beyond that point, it will deliver only the current required to hold the batteries at the battery voltage setting.

Maximum charge rate and maximum charge voltage are set using switch bank #2. The combined settings of switches 3,4 and 5 determine the max charge voltage. Switches 6,7 and 8 determine the max charge current. The factory setting for max charge voltage is 13.6, for max charge it is 110 amps.

The battery charger feature may be defeated. Switch 2 of switch bank #2 enables or defeats the charger. Charging is turned off when position 2 of switch bank #2 is turn off.

If DC loads are connected to the battery while the battery is charging, the charger will compensate for the load - up to 110 amps. Rather than limit the charge rate to the maximum the unit can deliver on a continuous basis, the charger is designed to deliver very high charge rates for moderate periods. With this design feature it is possible for the charger to thermally cycle on and off while charging at high rates for extended periods.

The performance of the battery charger is dependent upon the peak AC voltage available. Therefore, small variations in peak voltage result in large variations in the amount of energy to the charger. Standard public power of 117V has a peak voltage of 164V. Because a battery charger uses only the top portion of the input sine wave, the charger requires 164 peak AC volts to reach its maximum charge rates.

It takes a powerful AC generator set to maintain a 164 volt peak waveform while delivering the current necessary to operate the charger at its maximum rate (typically 6kw). Smaller generators will have the tops of their wave forms clipped under such loads. Running at these reduced peak voltages will not harm the charger, but it will limit the maximum charge rate. Large auxilliary loads may exacerbate this problem.

Be sure not to charge your batteries at higher voltages and/or currents than their manufacturers recommend. This is a very powerful charger. If misused it may damage your batteries.

Table 2 - Switch Bank #2, AC Transfer and Charger

		Switch Numbers							
		1	2	3	4	5	6	7	8
Ac Transfer Enable		off	---	---	---	---	---	---	---
Battery Transfer Enable		ON	---	---	---	---	---	---	---
Battery Charger Enable		---	ON	---	---	---	---	---	---
Maximum charge rate	2	---	ON	---	---	---	off	off	off
Maximum charge rate	20	---	ON	---	---	---	off	off	ON
Maximum charge rate	40	---	ON	---	---	---	off	ON	off
Maximum charge rate	60	---	ON	---	---	---	off	ON	ON
Maximum charge rate	75	---	ON	---	---	---	ON	off	off
Maximum charge rate	90	---	ON	---	---	---	ON	off	ON
* Maximum charge rate	110	---	ON	---	---	---	ON	ON	off
* Maximum charge rate	120	---	ON	---	---	---	ON	ON	ON
Maximum charge voltage	13.1	---	ON	off	off	off	---	---	---
Maximum charge voltage	13.6	---	ON	ON	off	off	---	---	---
Maximum charge voltage	14.0	---	ON	off	ON	off	---	---	---
Maximum charge voltage	14.3	---	ON	ON	ON	off	---	---	---
Maximum charge voltage	14.7	---	ON	off	off	ON	---	---	---
Maximum charge voltage	15.0	---	ON	ON	off	ON	---	---	---
Maximum charge voltage	15.4	---	ON	off	ON	ON	---	---	---
Maximum charge voltage	15.7	---	ON	ON	ON	ON	---	---	---

* Requires at least 164 peak AC volts input

Note - The "---" indicates that this switch number does not affect the function listed to the left on the chart.

Automatic Transfer Modes

The automatic transfer feature can be programmed to operated in either of two modes.

AC Transfer Mode

In this mode the inverter automatically becomes a battery charger whenever AC power is delivered to its AC inputs. While in the battery charger mode the inverter's AC input is internally connected to the inverter's AC output. There is

a 15 second time delay between when the inverter senses that AC is present at its input and when the transfer is made. This delay was built in to provide time for a generator to spin-up to a stable voltage and avoid relay chattering. The factory setting is for "AC Transfer Mode". This is the correct mode for applications where AC is not continuously available.

In order to select "AC Transfer Mode", switch 1 of switch bank #2 is turned off. When "AC Transfer Mode" is selected switch bank #3 is not used.

Battery Transfer Mode

For situations where AC power is continuously available, the inverter may be programmed to transfer to charger operation based upon battery voltage. In this mode, the inverter uses the battery voltage to make its decision to operate as a charger or inverter.

In order to select "Battery Transfer Mode", switch 1 of switch bank #2 is turned on.

Switch bank #3 is used to set the low and high battery transfer points. When the battery voltage equals the "Transfer to AC" setting, the inverter changes to charger operation. When the battery voltage equals the "Transfer to inverter" setting the unit changes to inverter operation. The factory voltage setting for transfer to charger mode is 11.4V. Return to inverter mode is factory set for 13.5V.

Table 3 lists the switch positions for the available transfer voltages.

Battery transfer mode is typically used only in installations that have an external source of AC power available at all times.

Table 3 - Switch Bank #3/Battery Transfer Mode

		Switch Number					
VDC		1	2	3	4	5	6
Transfer to AC input at	10.1	---	---	---	off	off	off
Transfer to AC input at	10.4	---	---	---	off	off	ON
Transfer to AC input at	10.7	---	---	---	off	ON	off
Transfer to AC input at	10.9	---	---	---	off	ON	ON
Transfer to AC input at	11.2	---	---	---	ON	ON	off
Transfer to AC input at	11.4	---	---	---	ON	off	ON
Transfer to AC input at	11.6	---	---	---	ON	ON	off
Transfer to AC input at	11.9	---	---	---	ON	ON	ON
Transfer to inverter at	12.9	off	off	off	---	---	---
Transfer to inverter at	13.2	ON	off	off	---	---	---
Transfer to inverter at	13.5	off	ON	off	---	---	---
Transfer to inverter at	13.7	ON	ON	off	---	---	---
Transfer to inverter at	14.0	off	off	ON	---	---	---
Transfer to inverter at	14.2	ON	off	ON	---	---	---
Transfer to inverter at	14.4	off	ON	ON	---	---	---
Transfer to inverter at	14.7	ON	ON	ON	---	---	---

NOTE: "---" indicates that this switch does not effect function.

Transfer Switching Speed

When switching from standby to inverter mode, the inverter will "soft start" the load tapering up to full voltage. The "soft start" time is about 1/2 second. Note: because of this soft-start feature, standby models should NOT be used for uninterruptable power supplies (UPS).

When switching from inverter to standby, the inverter waits approximately 10 seconds to insure the AC source is stable (generator up to speed) and then makes the transfer in approximately 40 milliseconds.

DIGITAL VOLTMETER OPTION

This option is available only available with standby models. It can be factory or user installed.

DIGITAL VOLTMETER FUNCTIONS

- **Battery Voltage** - Reads average battery voltage while in standby or inverter mode. Operates with the inverter on or off.
- **Charge Rate** - Reads average battery charge rate in amps.
- **Source Hz** - Reads the frequency of the external AC source which is supplying the power to charge the batteries (public power or generator).
- **Peak Volts In** - In order for the battery charger to deliver its rated current, it must be supplied with at least 164 peak volts. If the source voltage is sinusoidal then the RMS equivalent is 117 VAC ($164 / 1.41 = 117$). If the peak voltage is above 200 volts, the meter will read "OFL". This condition is dangerous to household electronic appliances - TV's, VCR's, stereo's, etc. Correct this problem at the generator.

Installation by User

Disconnect the battery, just in case you drop a mounting screw. Touch the heat sink to eliminate any static charge. Remove the lexan front cover and set it to the side carefully. Orient the DVM board so the digital readout is at the top. The female connector on the DVM board aligns with the vertical row of pins located 3 inches from the left edge of the mother board. Notice the 4 standoffs that you will be fastening the DVM board to. Align the connectors carefully, then gently press the DVM board onto the main PC board. Check again to see that you have aligned the connector properly - the holes on the DVM circuit board should match the standoffs on the mother board. Using the 4 #4 philips head screws supplied, fasten the board in place. There are holes in the heat sink that  are positioned in line with the standoffs. They will accept a slender screw driver. Replace the front cover. Reconnect the battery - CAREFULLY!

INSTALLATION

ENVIRONMENT

Inverters are sophisticated electronic devices and should be treated accordingly. When selecting the operating environment for the inverter don't think of it in the same terms as other equipment that works with it, e.g. batteries, diesel generators, motor generators, washing machines etc. It is a highly complex device. There are nearly 50,000 silicon junctions in its output devices and integrated circuits. The crystal oscillator runs at 4 megahertz. The drive circuitry timing is accurate to .1 millionth of a second. Genetically speaking, it is a cousin to stereo equipment, television sets or computers. Steps have been taken to improve tolerance to hostile environments. Circuit boards are covered with a protective coating. All electro-mechanical connections use special non-oxidizing compound. Metal components are plated. However, in a condensing environment (one in which humidity and/or temperature change cause water to form on components) all the ingredients for electrolysis are present - water, electricity and metals. In a condensing environment the life expectancy of the inverter is indeterminate and the warranty is voided.

It is in your best interests to install the inverter in a dry, protected location away from sources of high temperature.

Locate the inverter as close to the batteries as possible in order to keep the battery cables short. However, do not locate the inverter in the same compartment as the batteries. Batteries generate hydrogen sulfide gas which is very corrosive to electronics equipment - and everything else. They also generate hydrogen and oxygen. If accumulated, this mixture could be ignited by an arc caused by the connecting of battery cables or the switching of the relay in the standby model.

Do not mount the inverter in a closed container. If unrestricted air flow is not available to cool the heat sink and the unit is run at high power, the protection circuitry will quickly reduce the surge power and eventually turn the unit off.

The inverter may be mounted on a vertical or horizontal surface, in any orientation using the four grommets on the bottom flanges. However, the best continuous power performance will be attained by mounting it on a shelf with its heat sink near the edge.

In RV and marine installations it is advantageous to mount the inverter so that it is isolated from vibration.

Treat the inverter as you would any fine piece of electronic equipment.

AC CONNECTIONS

Installation should be done by a licensed electrician.
Consult local code for the proper wire sizes, connectors and conduit.

A five station external terminal block is used to make the AC connections. The terminal block is located on the right-hand side of the inverter. A cover box for the terminal block is shipped loose in the shipping box. On the standard model the terminal block is used only for hardwiring the inverter's AC output. With the standby option, the terminal strip is also used to hardwire the AC input. Consult your local code for proper wire sizes, connectors, conduit, etc. We recommend 12 gauge for the standard model and 10 gauge for units with the standby option.

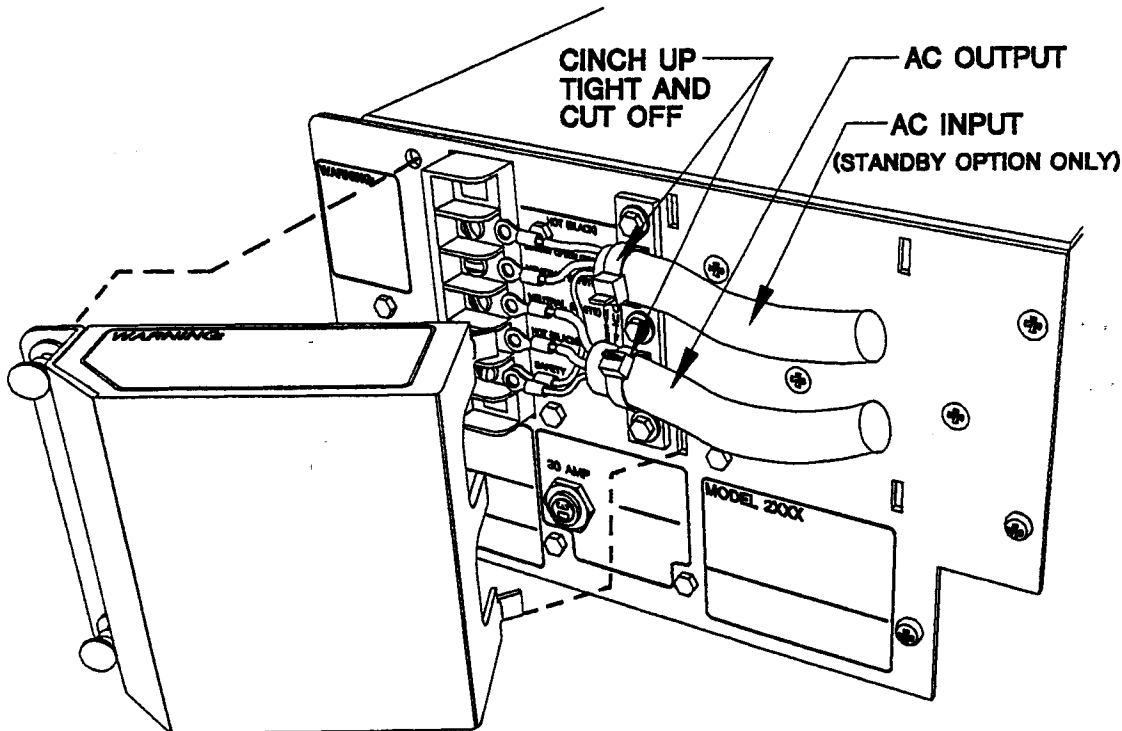

Figure 2, Hardwire Terminal

Disconnect the inverter from the battery. Solder the spade terminals supplied to the AC leads. Feed the wires thru the wire ties on the side of the inverter. See *Figure 2*. Following the wiring guide on the side of the chassis, connect the hot(black), neutral (white) and safety (green) wires to the terminal block and tighten securely. Tighten the wire ties by pulling on their ends until the loop fits snugly about the wires. Trim the end(s) of the wire tie(s). The cover box for the terminal strip has two tabs that face to the back of the inverter and fit into rectan-

gular slots on the inverter's side. Position the cover against the side of the inverter and press on the plastic fasteners to lock the cover in place.

Note that chassis ground is connected to battery negative. This is a negative ground system.

Marine Installations

If keeping the AC ground and DC ground separate is desired, then the green safety ground wire should not be connected to the inverter's chassis. The inverter's output is floating. With the safety ground unused the inverter's chassis is grounded to battery negative. The AC side is grounded to that of the ship's AC system.

Important Precautions

The output side of the inverter's AC wiring should at no time be connected to public power or a generator. This condition is far worse than a short circuit. If the unit survives this condition, it will shut down until corrections are made.

On standby models the installation should insure that the inverter's AC output is, at no time, connected to its AC input.

Review the installation diagrams included.

BATTERY CONNECTIONS

THIS INVERTER IS NOT REVERSE POLARITY PROTECTED. If the positive terminal of the battery is connected to the negative terminal of the inverter and vice versa, the result is the instantaneous failure of nearly every power FET. To compound your misfortune, this type of failure is very obvious, and it's not covered under the warranty. So, pay close attention and double-check when making the battery connections.

The inverter's maximum peak current requirement is 950 amps. This is a considerable amount. If battery cables are too small and/or connections are loose, efficiency and maximum output power are degraded. Small cables or loose connections can also cause over heating of the wire and/or terminals which could be dangerous.

Make the battery cables as large and as short as possible. Tape the battery cables together. This reduces the inductance of the wire resulting in a better waveform and less current in the inverter's filter capacitors.

Code your battery cables with colored tape or heat shrink tubing. Cable ends must have soldered, copper ring terminals.

Place the ring terminal over the bolt and directly against the inverter's copper terminal. Tighten the 5/16 nut to 10-15 ft./lbs.

Never disconnect the battery cables while the inverter is delivering power or battery charger is operating. Always turn the unit off first.

Battery Cable Size

Battery cables cannot be too large. Under sized cables result in additional stress on the inverter, lower efficiency, reduced peak power and lower peak output voltage. We recommend 4/0 cable for 10 lengths and 2/0 cable for 5 foot lengths. Don't use cables that are too small and degrade the efficiency that we have worked so hard to achieve and you have paid so much to own.

ESTIMATING BATTERY REQUIREMENTS

Batteries are the inverter's fuel tank. The larger the batteries, the longer the inverter can operate. In order to determine the proper battery bank size, it is necessary to compute the number of amp hours that will be used between charging cycles. When the required amp/hrs are known, size the batteries at approximately twice this amount. Doubling the expected usage insures that the batteries will not be overly discharged.

To compute amp/hrs, the requirements of each appliance that is to be used is determined and then added together. *Table 4* provides a means of figuring the amp hours drawn by various types and sizes of loads. To use this table (1) enter on the left with the row of the appropriate appliance or wattage (2) enter from the top with the column of the length of time the appliance will be run, (3) the intersection of row and column provides the amp hours that will be consumed.

Follow this procedure for each item you want to use with the inverter. Add the resulting amp hour requirements. The minimum properly sized battery bank is double this amount.

If you haven't forgotten your high school algebra you may wish to compute your battery requirements more exactly. The critical formula is $Watts = Volts \times Amps$. Divide the wattage of your load by the battery voltage (12 VDC) to determine the amperage the load will draw from the batteries. Multiply the amperage times the hours and you have, reasonably enough, amp/hrs. Remember that amounts of time less than an hour will be fractions (10 minutes is 1/6 of an hour).

Table 4 - Watts out vs. Time vs. Battery Drain

		Time in Minutes				
Watts	Appliance	5	15	30	60	120
30	Stereo	.3	.7	1.4	2.5	5.0
60	B&W TV	.5	1.4	2.7	5.4	9.1
100	Color TV	.8	2.7	4.5	9.1	18.1
200	Computer	1.5	4.5	9.0	18.1	36.3
400	Blender	3.0	9.0	18.1	36.3	72.5
800	Skil Saw	6.0	18.1	36.3	72.5	145.0
1000	Toaster	7.6	22.5	45.3	90.1	180.2
1200	Microwave	9.3	27.8	55.6	111.1	222.2
1800	Hot Plate	14.5	43.5	87.1	174.2	348.4
		Amp/Hours				

Notes:

If the AC current is known, then, the battery amperage will be 10 times the AC amperage. For 240 VAC loads the battery amperage will be 20 times the AC amperage.

Motors are often marked with their starting current rather than their running current.

Refrigerators and ice makers typically run about 1/3 of the time and draw about 2.5 amps at 117 VAC. Therefore, their average battery current is about 4.2 amps (2.5 X 10 X 1/3).

APPLICATIONS

RESISTIVE LOADS

These are the loads that the inverter finds the simplest and most efficient to drive. Voltage and current are in phase, or, in this case, in step with one another. Resistive loads usually generate heat in order to accomplish their tasks. Toasters, coffee pots, heaters and incandescent lights are typical resistive loads. While the inverter is happy to run these loads and manufacturers are happier still to publish efficiency curves based on them, chemical energy sources, such as propane, are often more practical to use - Particularly if the load is large.

Inductive Loads

Any device that has a coil of wire in it probably has an inductive load characteristic. Most electronics have transformers (TV's, stereos, etc.) and are therefore inductive. Typically, the most inductive loads are motors. And the most difficult load for the inverter to drive will be the largest motor you manage to start. With inductive loads the rise in voltage applied to the load is not accompanied by a simultaneous rise in current. The current is delayed. The length of the delay is a measure of inductance. The current makes up for its slow start by continuing to flow after the inverter stops delivering a voltage signal. How the inverter handles current that is delivered to it while it is essentially "turned off", affects its efficiency and "friendliness" with inductive loads. The best place for this out of phase current is in the load, and "impulse phase correction" routes it there. The return current of an inductive load is making its second pass thru the inverter. Whenever current is run thru transformers and semiconductors, some is wasted as heat. Therefore, inductive loads are run less efficiently.

Induction motors (motors without brushes) require 2 to 6 times their running current on start-up. The most demanding are those that start under load, eg. compressors and pumps. The largest of this type that the inverter will run varies from 1/3 to 3/4 hp. Of the capacitor start motors, typical in drill presses, band saws, etc., the largest you may expect to run is 1 to 1.5 hp. Since motor characteristics vary, only testing will determine if a specific load can be started and how long it can be run.

Universal motors are generally easier to start. The inverter may start up to 2.5 hp universal motors.

If a motor fails to start within a few seconds, or after running for a time it begins to lose power, it should be turned off. When the inverter attempts to start a motor, or any load, that is greater than it can handle it will turn itself off after about 20 seconds.

PROBLEM LOADS

TRACE ENGINEERING inverters can drive nearly every type of load. However, there are special situations in which the inverter may behave differently than public power.

- **Very small loads:** - If the power consumed by the device is less than the threshold of the search mode circuitry, it will not run without the inverter being programmed to stay in the 117V state, or without a small companion load running with it. See the section called "Search Mode Control" for details.
- **Florescent lights & power supplies** - Some devices when scanned by the load sensor cannot be detected. Small fluorescent lights are the most common example. (Try altering the plug polarity-turn the plug over). Some computers and sophisticated electronics have power supplies that do not present a load until line voltage is available. In these cases a "Mexican standoff" occurs with each unit waiting for the other to begin. To drive these loads either a small companion load must be used to bring the inverter out of its search mode, or the inverter may be programed to remain in the 117V state. See the section "Using the Programing Switches".
- **Microwave ovens** - Microwave ovens are sensitive to peak output voltage. The higher the voltage, the faster they cook. Typical public power varies from 155V to 180V peak. Inverter peak output voltage is dependent on battery voltage and load size. The high power demanded by a full sized microwave will drop the peak voltage several volts due to internal losses. Therefore, the time needed to cook food will be increased if battery voltage is low.
- **Clocks** - The inverter's crystal controlled oscillator keeps the frequency accurate to within a few seconds a day. However, external loads in the system may alter the inverter's output wave form causing clocks to run at different speeds. This may result in periods during which clocks keep time and then mysteriously do not. Most clocks do not draw enough power to trigger the load sensing circuit. In order to operate without other loads present, the load sensing will have to be defeated. See the section "Using the Programing Switches".
- **Searching** - If the amount of power a load draws decreases after it turns on, and if the "on" load is less than the threshold of the load sensing, it will be turned alternately on and off by the inverter. For example: the load sensing threshold is set for 16 watts. A ten watt incandescent light is turned on. Cold, the light bulb looks like a 60 watt load, so the load sensing detects it and the inverter output goes to 117V. The filament of the bulb heats, increasing its resistance, and the power drawn drops to 10 watts. Since this is below the load sensing threshold the inverter returns to its search mode and the light goes out.

- **Ceiling Fans** - Most large diameter, slow turning fans run correctly but generate more noise than they would connected to public power. The high speed type fans operate normally.
- **Dimmer Switches** - Most dimmer switches lose their ability to dim the lights and operate either fully on or off.
- **Rechargeable Devices** - Sears "First Alert" flashlights fail when charged by the inverter. "Skil" rechargeable products are questionable. Makita products work well. When first using a rechargeable device, monitor its temperature for 10 minutes to insure that it does not become abnormally hot. That will be your indicator that it should not be used with the inverter.
- **Laser Printers** - While many laser products are presently operating from TRACE ENGINEERING inverters, and we have personally run a Texas Instruments Microlaser and HP IIP, we have had reports of an HP III and a MacIntosh Laser Writer failing under inverter power and therefore do not recommend their use.
- **Electronics** - AM radios will pick up noise, especially on the lower half of their band. Inexpensive tape recorders are likely to pick up a 120 hz buzz. Computers should not be run while large loads are being started. If a load is large enough to require "soft starting" it will "crash" the computer.
- **Low Battery Dropout** - If your battery bank cannot deliver the necessary amperage to drive a particular load without falling below the low voltage protection point for three seconds, the inverter will turn off to protect itself. With the inverter off, the battery voltage will rise and then it will resume operation. Since this cycling happens quickly it can be mistaken for a problem with the inverter.

Medical Equipment

Trace Engineering inverters were not designed to be used to run either life supporting or life saving equipment. Do so only at your own risk.

Dimensions Height 6.75", width 11.5", depth 12.5"
Weight 39 lbs.

Standby Option Specifications

Maximum charge rates Programable at 2, 20, 40, 60, 75, 110 or
120 amps
Maximum charge voltage Programable at 13.1, 13.6, 14.0, 14.3, 14.7
30.4, 30.8 or 31.4 volts
Transfer voltages To inverter - programable at 25.8, 26.4, 27.0,
15.0, 15.4, or 15.7 volts
To AC - programable at 10.1, 10.4, 10.7, 10.9,
11.2, 11.4, 11.6 or 11.9 volts
Transfer Relay 1 hp 30 amp
AC input circuit breaker 30 amps
Power Consumption011 amps / .13 watts

Digital Volt Meter Specifications

Frequency 40 to 70 Hz +/- 3 digits
Battery Voltage 9 to 16 volts - +/- 3 digits
Peak Voltage 100 to 199 volts - +/- 2%
Charge Rate 0 to 20 amps - +/- 10%
20 to 80 amps - +/- 5%
80 to 120 amps - +/- 10%

All specifications subject to change without notice.

Options

The Series 2000 inverters are designed to accommodate a wide range of options. All, except the standby option, may be installed by the user. The standby option can only be retrofitted by the factory.

Standby option (SB) - Allows the inverter to operate as a programable battery charger. Automatic transfer and return can be set to be triggered by either public power condition or battery voltage. Low battery transfer and return voltages are adjustable. Battery charge rate and maximum charge voltage are user selectable.

Digital Voltmeter (12DVM) - Reads peak AC input voltage, battery voltage, charge rate, and AC source frequency.

TECHNICAL INFORMATION

MODEL 2012 SPECIFICATIONS

Rated Power @ 20 deg.C	3000 watts for 10 minutes 2000 watts for 30 minutes 1400 watts continuous
Surge Power	6000 watts incandescent lights
Motor Starting Current	45 RMS amps with 22 VDC battery
Efficiency	Over 90% from 60 to 1400 watts
Input current	(.028) amps / .33 watts in search mode .600 amps with search mode defeated 190 amps at rated power 950 amps short circuit
Load sensing (watts)	Programable @ 1, 2, 6, 16, 40, defeated
Input voltage	10.8 to 15.2 to maintain regulated output voltage 8.8 to 10.8 non-regulated output voltage Below 8.8 subject to low voltage cutout with auto reset
Output voltage regulation	120 VAC +/- 2 volts
Frequency regulation	Crystal controlled - +/- .04%
Power factor	All conditions allowed (-1 to 1)
Wave form	Modified sine wave, dynamic impulse phase correction for inductive loads
Reverse polarity	1800 amp maximum
Output protection	Passive and dynamic energy push back absorbers Transient/surge absorber
Protection circuitry (with auto reset)	
High battery	above 15.2V with (with auto reset) return below 14.8V
Low battery	below 9V for 3 sec.
Overcurrent	instantaneous limiting with linear temperature compensation
Environmental Characteristics	
Operating ambient temperature	0 C to +60 C
Non-operating ambient temperature	-55 C to +75 C
Altitude operating	to 15,000 ft.
Altitude non-operating	to 50,000 ft

Remote Control (RC2000/12) - Provides a remote panel with an On/Off switch and digital voltmeter that reads the same functions as the DVM option. Status indicator lights show On/Off, search mode, error condition and AC present.

Remote Control (RC/2) - Provides an on/off switch and LED that indicates on, off, search mode and overload conditions.

Low Battery Cut-out (LBCO/12) - Monitors battery voltage and current being drawn by the inverter to determine if the inverter should be shut down to protect the batteries.

Stacking Interface (SI/B) - Allows two units to be paralleled for twice power.

Turbocharger (ACTC) - Temperature activated fan cooling kit that increases the continuous power rating by 400 watts. It replaces the bottom cover and allows normal convection cooling. It is also useful if the inverter is installed in an area with restricted ventilation.

Battery Cables (BC5) & (BC10) - 4/0 flexible 2100 strand cables. Color coded with crimped and soldered copper terminals. Two 5 foot or two 10 foot lengths.

Design Goals

Trace Engineering inverters are designed to excel in the following areas:

Efficiency

The primary types of power transfer losses must be minimized in order to run efficiently.

- **Transformer Losses** - The transformer design significantly affects the inverter's efficiency. The characteristics that make a transformer efficient at high power make it inefficient at low power. This design favors high power efficiency, and uses sophisticated search mode circuitry to maintain efficiency at low power. Special winding techniques previously used only in very high power equipment are employed and further enhance high power performance.
- **Transistor Losses** - The FET's (field effect transistors) used in the output stage act like resistors. The more FET's that are put in parallel, the lower their effective resistance. The lower the resistance the lower the losses. This design uses 36 power FET's in its output stage - a lot. The signal that is used to turn them on and off is important to efficiency as well as reliability. A regulated switching power supply is dedicated to the output stage. With it, the FET's are driven on and off very quickly with the proper voltage to optimize their characteristics.

- **Connector Losses** - All connections are tin plated copper to copper with a one square inch surface area. All primary currents are carried in copper buss bars to minimize losses and corrosion problems.
- **Reactive Loads** - These loads present special requirements to an inverter. The current flow is out of phase with its voltage waveform. The trailing current waveform must be properly handled or the performance of the inverter will be seriously degraded. The "impulse phase correction" circuitry returns most of this current back to the load where it does useful work.

High Power

The ingredients for high power are a subset of those for high efficiency. High power is high efficiency at high currents. Attaining maximum performance requires protection circuitry that allows full use of the FET's safe operating area. To do this the unit monitors temperature, current and time. The transformer's low DC resistance, the low "on" resistance of the FET's and the smart protection circuitry combine to generate substantial power from the Series 2000's small package.

In order to run loads that require more start power than run power, the inverter must be able to deliver power well beyond its continuous rating for a short period of time. This is the "surge power". Its published value is often determined by the marketing department. This is partly because there are no standards for surge power, and partly because it cannot be represented by a simple or single number. For example, the Model 2012 will deliver 45 amps into a 6000 watt load with only 11V batteries. It will light over 6000 watts of incandescent bulbs. More importantly, the inverter can start any load that is on the edge of its time versus power envelope. Which is to say, it will start anything that it can run for at least a few minutes.

Reliability

Achieving reliability requires synthesizing a carefully controlled drive circuit design, extensive protection circuitry and sound construction techniques.

A description of the drive circuit design is beyond the scope of this manual, but has been touched upon in the above discussion of efficiency.

The protection circuitry monitors the following conditions: low battery, high battery, short circuit, over current, reverse output voltage and temperature. Low battery voltage is not harmful to the inverter but could damage the batteries. High battery voltage is not harmful to the inverter either, but results in high peak output voltages which could damage electronic equipment. The over current protection is triggered when load demands exceed the safe operating area of the transistors. Reverse output voltage protection guards the unit from accidental connection to the public power. Limited lightning protections is supplied by

surge protection devices in the secondary. Temperature protection is provided by solid state temperature sensors located on the heat sink and transformer. The power that a semiconductor can deliver is in part dependent upon its temperature. Therefore, the protection scheme adjusts the protection parameters linearly according to temperature. This utilizes the full capability of the FET's. If either sensor exceeds a threshold (heatsink-80 deg.C, transformer-110 deg.C) the inverter shuts down.

The construction method employs Motorola's "tight packaging technique". This refers not to the size of the unit, but rather the concept of keeping all drive signal paths as short as possible. With the minimal use of wires and nearly all circuitry contained on one double sided thru-hole plated printed circuit board, consistent performance and superior reliability are assured.

Performance Graphs

Power vs. Time

In order to provide the maximum utility, TRACE inverters are allowed to operate at power level that can not be maintained continuously. Typically, large loads are operated for only short periods of time. The graph shows how loads that are larger than the inverter can sustain continuously are still able to be operated for useful times.

The length of time that the inverter can operate at high power is limited by temperature. When large loads are run, the inverter's temperature increases. At the point where more heat is created in the inverter than can be dissipated, its ability to operate becomes time limited. The accompanying graph indicates how long the inverter can operate at different power levels.

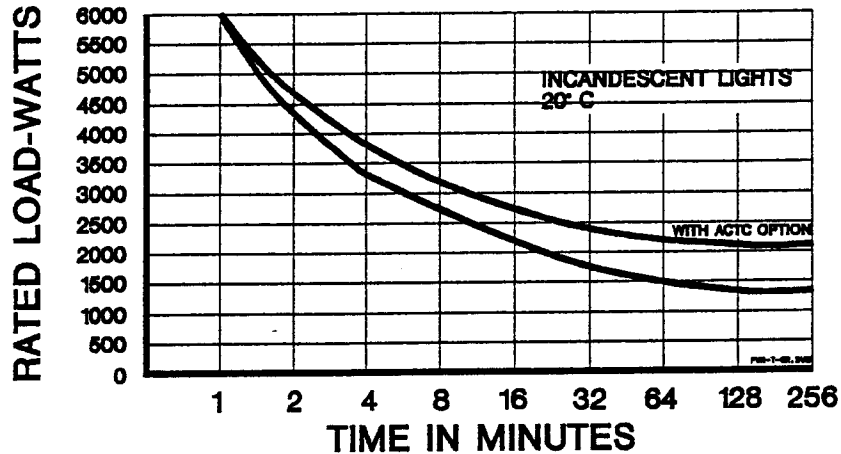

Figure 3, Power vs Time

This graph assumes an ambient operating temperature of 20⁰ C and resistive loads. Reactive loads (motors, florescent lights) and/or elevated ambient temperatures will reduce the time that the inverter can operate at a particular power level.

Power vs. Efficiency

There are primarily two types of losses that combine to create the efficiency curve. The first is the energy that is required to operate the inverter at full output voltage while delivering no current. This is the idle power. At low power levels it is the largest contributor to efficiency losses.

The second and largest source of loss is a result of the resistance of the transformer and power devices. The power lost here is proportional to the square of the output power. Therefore, losses at 2000 watts will be four times higher than losses at 1000 watts.

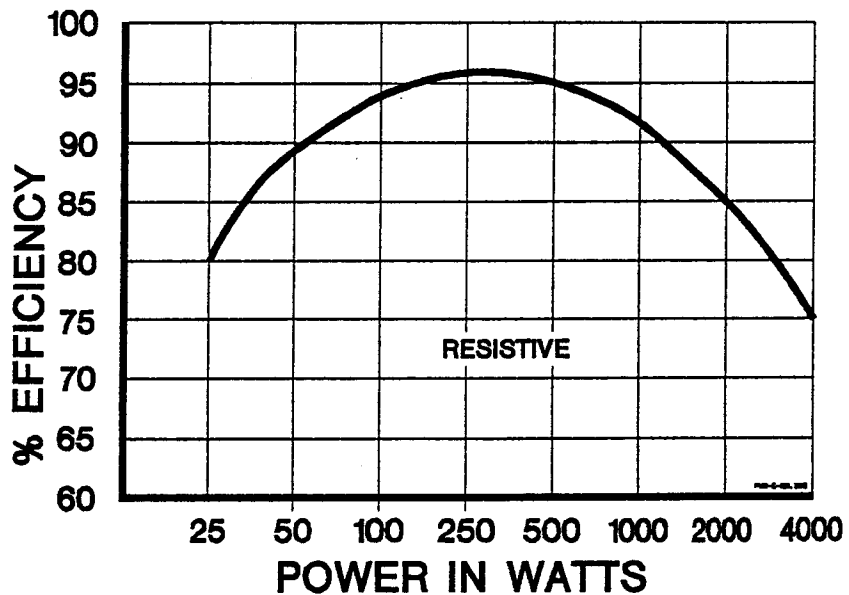

Figure 4, Power vs Efficiency

This graph represents the inverter's efficiency while operating resistive loads. Inductive loads such as motors are run less efficiently.

Maximum Regulated Power vs Battery Voltage

As the battery voltage is reduced, the maximum regulated power the inverter can produce decreases.

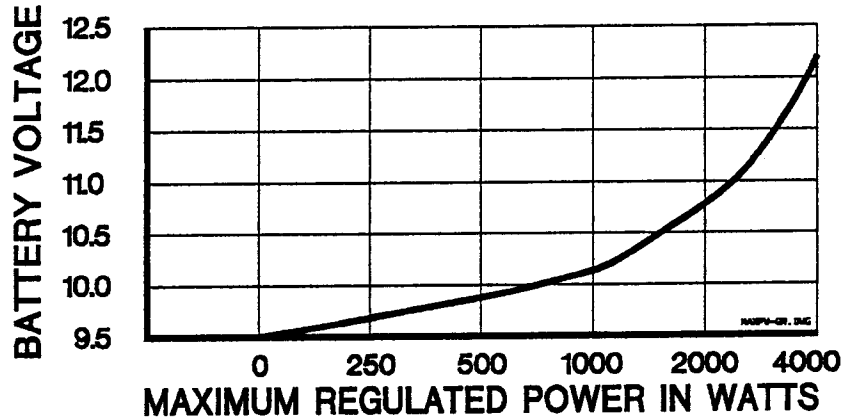

Figure 5, Maximum Regulated Power vs Battery Voltage

The inverter regulates by changing the width of its output waveform. When the inverter falls out of regulation its output is a square wave. The graph above defines the points at which the combination of power and battery voltages results in square wave output. The area above the line represents regulated output. The area below the line shows unregulated operating conditions.

Maximum Load vs Temperature

The current protection circuit is temperature compensated, therefore, the maximum sized load that the inverter can run changes with temperature. As the temperature of the power devices (FET's) increases the maximum allowable current is reduced. When the available current is reduced, the maximum size load the inverter can run is reduced.

The graph above shows the effect FET temperature has on maximum possible

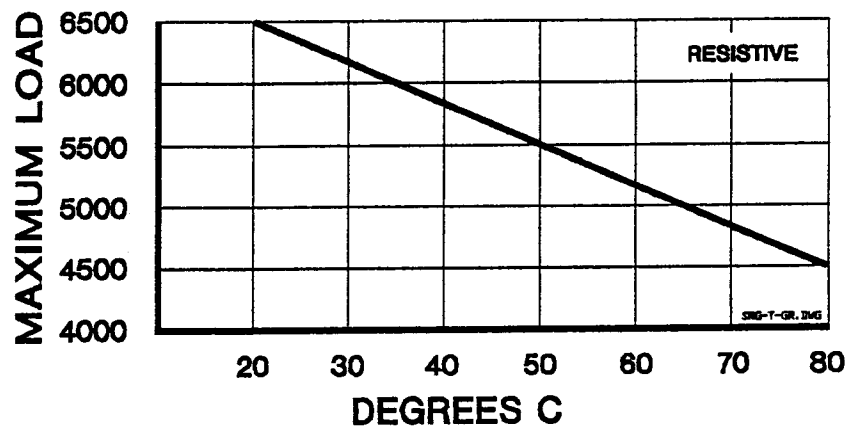

Figure 6, Maximum Load vs Temperature

loads. While the graph shows loads up to 6000 watts, the inverter will run out of regulation well below this level. Included in the manual is a graph depicting maximum regulated power vs battery voltage.

Charge Rate vs Time

The charger is allowed to operated at current levels that are beyond what it can sustain continuously. In many installations the charger quickly reaches the high voltage set point well before the thermal limit of the charger is realized. Once the maximum charge voltage is reached the charge rate begins to taper.

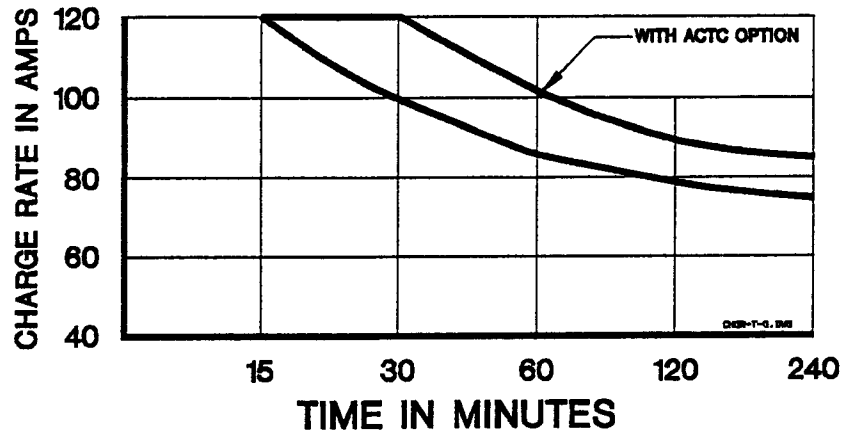

Figure 7, Charge Rate vs Time

This graph represents the maximum time the charger can operate at a fixed current.

Charge Rate vs Peak Input Voltage

This graph demonstrates the effect that peak AC voltage has upon the inverter's maximum charge rate capabilities.

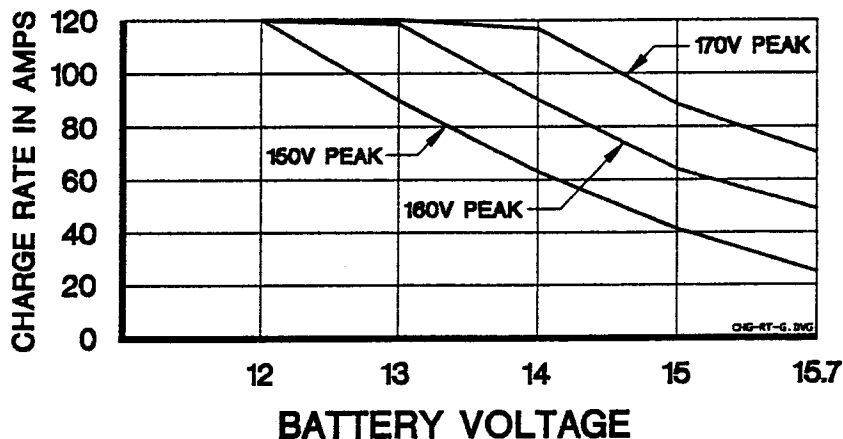

Figure 8, Charge Rate vs Peak AC Voltage

The performance of the battery charger is dependent upon the peak voltage available. In order to meet its ratings, 164 peak volts are required. A battery charger uses only the top portion of the input sine wave. Therefore, small variations in peak voltage result in large variations in the amount of the wave form that the charger has to work with. Standard public power of 117V has a peak voltage of 164V.

Installation Diagrams

A. Installation Using Plugs

Figure 9 shows a simple and fool-proof installation. This would typically be used in an RV that presently has a power cord that plugs into the shore power or the generator.

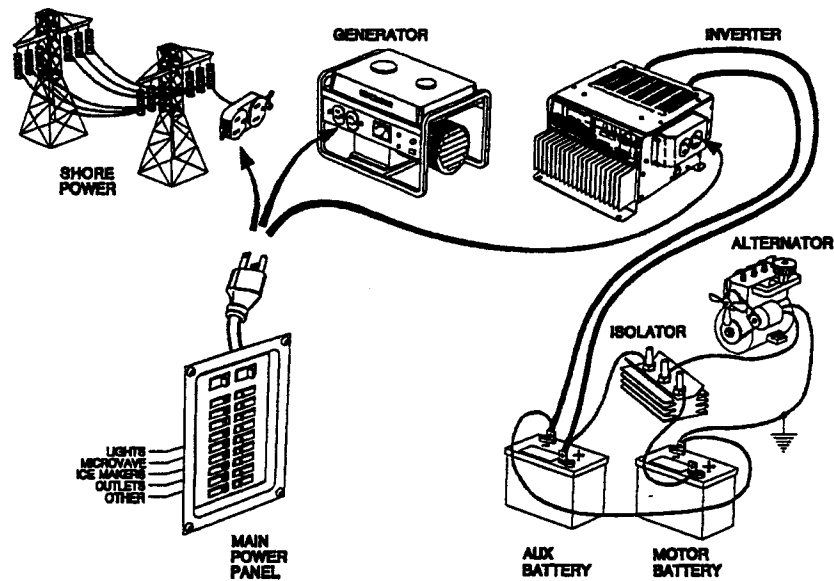

Figure 9, Installation Using Plugs

The power from the generator is terminated in a junction box with an AC receptacle. Similarly, the power from the inverter is terminated in a junction box. The shore power plug is simply plugged into the appropriate box.

B. Standby Inverter with Single AC Panel

In all installations it is important to insure that AC power from any source (generator, public power) is never fed to the inverter's AC output. With the standby option, it is essential that the inverter's AC output is not fed to its AC input. The diagram below is simple and meets these requirements. However, there are two precautions to keep in mind:

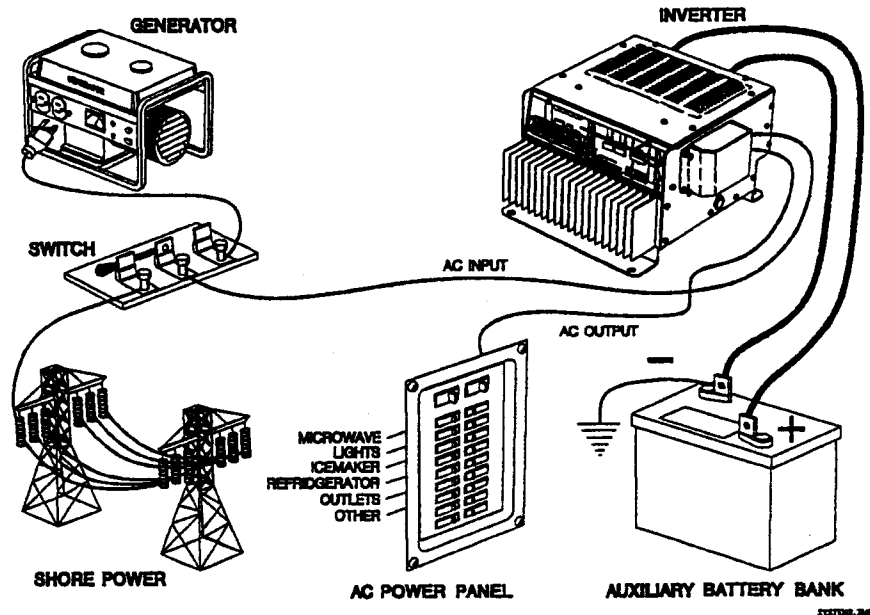

Figure 10, Standby Inverter with Single AC Panel

1) With only one AC panel encompassing all loads, the inverter could be connected to loads which are greater than it can run.

2) The maximum system current is limited by the inverter's 30 amp AC input breaker. Of this 30 amps as much as 20 may be consumed by the battery charger if it is charging heavily. This would leave only 10 amps available for other loads.

The above configuration is acceptable, but not recommended. Diagram "D" is preferable in that it isolates the inverter from inappropriate loads.

C. Standby Inverter with Two AC Panels

This is the recommended configuration for installing an inverter with the built in battery charger. It operates in the following manner. When there is power available at the main panel, the inverter's automatic transfer relay closes connecting the main panel to the sub-panel. When there is no AC present at the main panel, the relay opens and the sub-panel is fed AC power generated by the inverter.

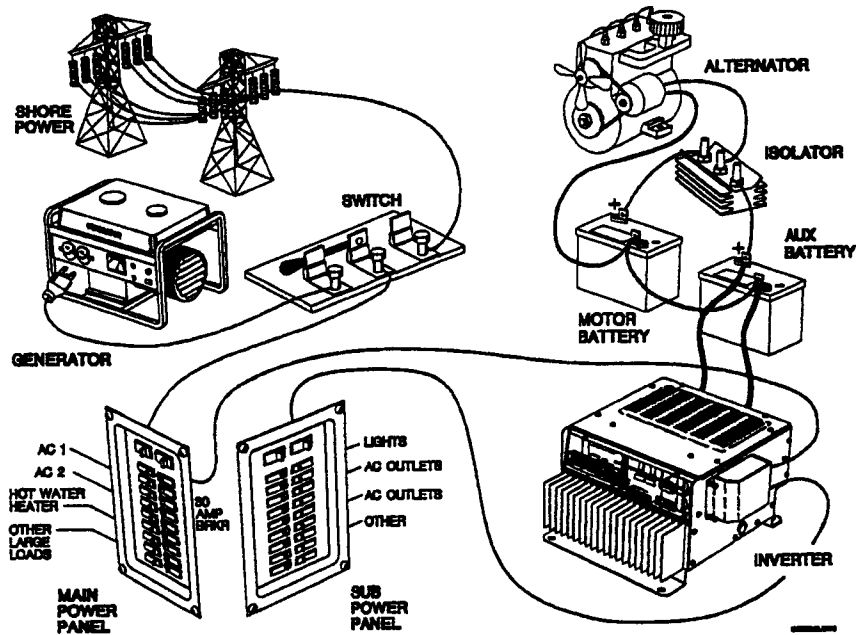

Figure 11, Standby Inverter with Two AC Panels

This installation automatically insures that public or generator AC power is never routed to the output of the inverter. The inverter's AC output cannot be fed to its input. Additionally, the inverter will only be connected to appropriately sized loads that are dedicated to the sub-panel.

The maximum current that can be used by the combination of sub-panel and battery charger is 30 amps. Of this 30 amps as much as 20 may be consumed by the battery charger if it is charging heavily. This would leave only 10 amps available for loads in the sub panel.

D. Inverter with Two AC Panels and External Relay

This is the recommended configuration for installing an inverter without the built in battery charger. It operates in the following manner. When there is power available at the main panel, the relay closes connecting the main panel to the sub-panel. When there is no AC present at the main panel, the relay opens and the sub-panel is fed AC power generated by the inverter.

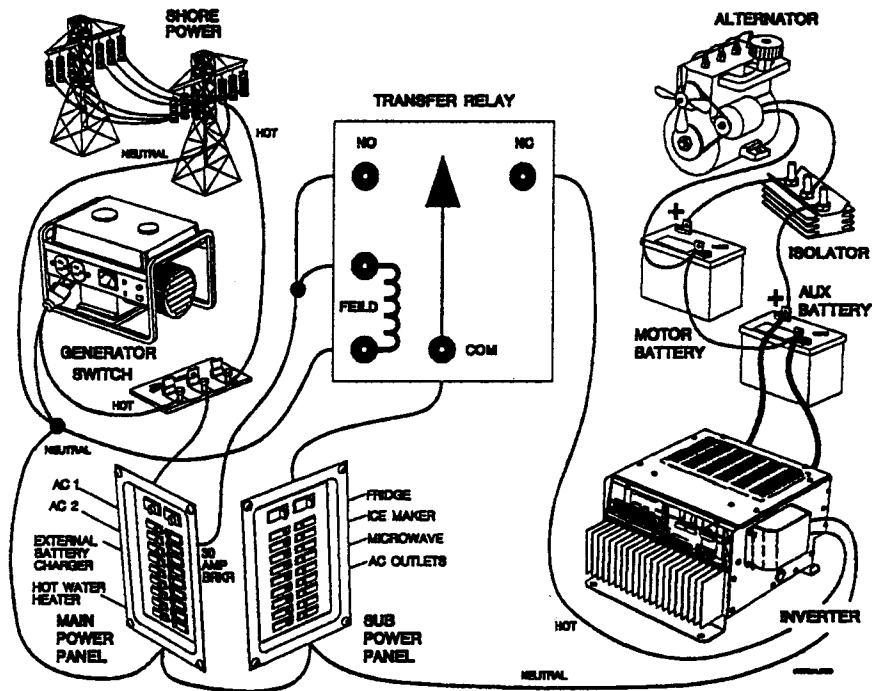
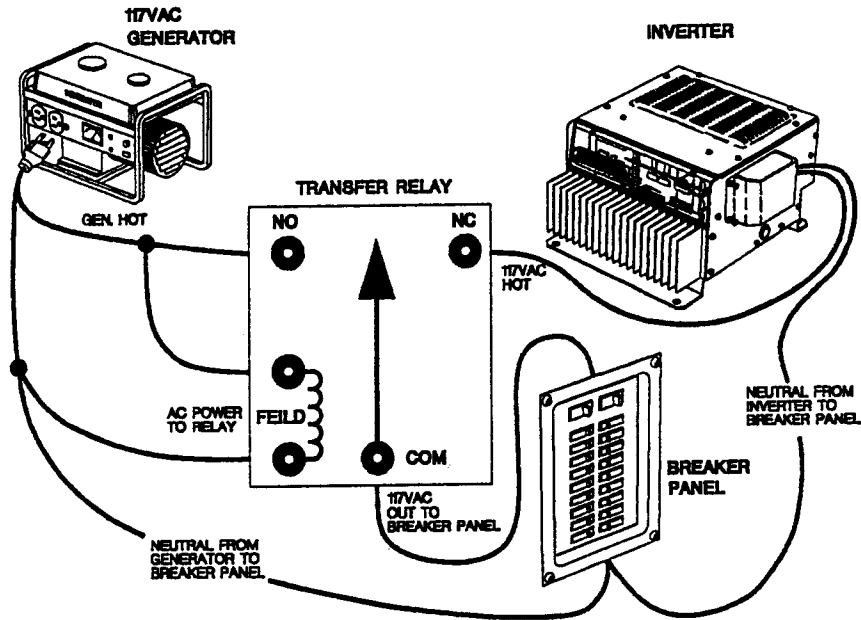

Figure 12, Two AC Panels with External Relay

This installation automatically insures that public or generator AC power is never routed to the output of the inverter. This setup also insures that the inverter will only be connected to appropriately sized loads.

External Transfer Relay Details

Using a transfer relay allows the AC panel to be automatically connected to the output of the inverter or the generator.



The proper relay to use is described as single pole - double throw - 30 amp - 117VAC. These relays are commonly available at electrical supply outlets for a cost of about \$14.00. Pre-wired relays enclosed in electrical boxes are also available thru system suppliers. These range in price from \$75 to \$250.

Limited Warranty

Trace Engineering Company warrants all Trace Engineering power products against defects in material and workmanship for a period of two (2) years from date of purchase and extends to all purchasers or owners of the product during the warranty period. Trace Engineering does not, however, warrant its products against any and all defects: (1) Arising out of material or workmanship not provided or furnished by Trace Engineering, or (2) resulting from abnormal use of the product or use in violation of the instructions, or (3) in products repaired or serviced by other than Trace Engineering repair facilities, or (4) in components or parts or products expressly warranted by another manufacture. Trace Engineering agrees to supply all parts and labor or repair or replace defects covered by this warranty with parts or products of original or improved design, at its option in each respect, if the defective product is returned to any Trace Engineering authorized warranty repair facility or to the Trace Engineering factory in packaging providing at least as much protection from damage as the original packaging, with all transportation costs and full insurance paid by the purchaser or owner.

ALL REMEDIES AND THE MEASURE OF DAMAGES ARE LIMITED TO THE ABOVE, AND CONSEQUENTIAL OR INCIDENTAL DAMAGES ARE EXCLUDED, EVEN IF TRACE ENGINEERING HAS BEEN ADVISED OF THE POSSIBILITY OF SUCH DAMAGES. ANY AND ALL OTHER WARRANTIES EXPRESS OR IMPLIED, ARISING BY LAW, COURSE OF DEALING, COURSE OF PERFORMANCE, USAGE OF TRADE, OR OTHERWISE, INCLUDING BUT NOT LIMITED TO IMPLIED WARRANTIES OF MERCHANTABILITY AND FITNESS FOR A PARTICULAR PURPOSE, ARE LIMITED IN DURATION TO A PERIOD OF (2) YEARS FROM THE DATE OF PURCHASE BY THE ORIGINAL RETAIL PURCHASER.

SOME STATES DO NOT ALLOW LIMITATIONS ON HOW LONG AN IMPLIED WARRANTY LASTS, SO THE ABOVE LIMITATIONS MAY NOT APPLY TO YOU. SOME STATES DO NOT ALLOW THE LIMITATION OR EXCLUSION OF INCIDENTAL OR CONSEQUENTIAL DAMAGE, SO THE ABOVE MAY NOT APPLY TO YOU. THIS WARRANTY GIVES YOU SPECIFIC LEGAL RIGHTS, AND YOU MAY ALSO HAVE OTHER RIGHTS WHICH VARY FROM STATE TO STATE.

Warranty Procedure

TO VALIDATE your warranty, the warranty card must be filled out and mailed to Trace Engineering within ten (10) days from the date of purchase. It is also advised that you KEEP YOUR BILL OF SALE as proof of purchase, should any difficulties arise concerning the registration of the warranty card.

WARRANTY REGISTRATION is tracked by model and serial numbers only, not by owner's name. Therefore, any correspondence or inquires made to Trace Engineering must include the model and serial number of the product in question. Be sure to fill in the model and serial number in the space provided below and keep this portion of the warranty card in a safe place for future reference.

WARRANTY SERVICE must be performed ONLY AT AN AUTHORIZED TRACE SERVICE CENTER, OR AT THE TRACE ENGINEERING FACTORY. It is recommended that advance notice be given to the repair facility to avoid the possibility of needless shipment. UNAUTHORIZED SERVICE PERFORMED ON ANY TRACE PRODUCT WILL VOID THE EXISTING FACTORY WARRANTY ON THAT PRODUCT.

FACTORY SERVICE: If you wish your Trace Engineering product to be serviced at the factory, it must be shipped FULLY INSURED IN THE ORIGINAL PACKAGING OR EQUIVALENT; this warranty will not cover repairs on products damaged through improper packaging. If possible, avoid sending products thru the mail. Be sure to include in the package:

1. Complete return shipping address (P.O. Box numbers are not acceptable).
2. A detailed description of any problems experienced, including the make and model numbers of any other equipment in the system, types and sizes of loads, operation environment, time of unit operation and temperature.

Repaired products will be returned freight C.O.D. unless sufficient return shipment funds are included with the unit.

Products sent to the factory from outside the U.S. MUST include return freight funds, and sender is fully responsible for all customs documents, duties, tariffs and deposits.

Record the model and serial number below and retain for your files:



Model _____
Serial Number _____
Date of purchase _____

DETACH THIS PAGE AND MAIL TO TRACE ENGINEERING

Warranty Information

Model including options _____

Serial Number _____

Purchase Date _____ Phone No _____

Owner's Name _____

Address _____

City _____ State _____ Zip _____

Where will the product be used?

- | | |
|--|---|
| <input type="checkbox"/> Primary home | <input type="checkbox"/> RV, motorhome, trailer |
| <input type="checkbox"/> Cabin / Vacation Home | <input type="checkbox"/> General office |
| <input type="checkbox"/> Pleasure boat | <input type="checkbox"/> Computer, telephone system |
| <input type="checkbox"/> Commercial boat | <input type="checkbox"/> Mobile equipment |

Type of product use (check all that apply).

- Commercial power backup
- Alternative energy (solar, wind, water)
- Primary source of AC power

Where did you learn of Trace products?

- | | |
|---|----------------------------------|
| <input type="checkbox"/> Magazine ad | <input type="checkbox"/> Catalog |
| <input type="checkbox"/> Magazine article | <input type="checkbox"/> Friend |
| <input type="checkbox"/> Dealer | <input type="checkbox"/> _____ |

Comments about the product you purchased: _____



5916 - 195th Street N.E., Arlington, WA 98223 Phone: (360) 435-8826 Fax: (360) 435-2229

visit our website at: www.traceengineering.com