

To deodorize your new chair

leave the chair in a well ventilated area for 1-2 days

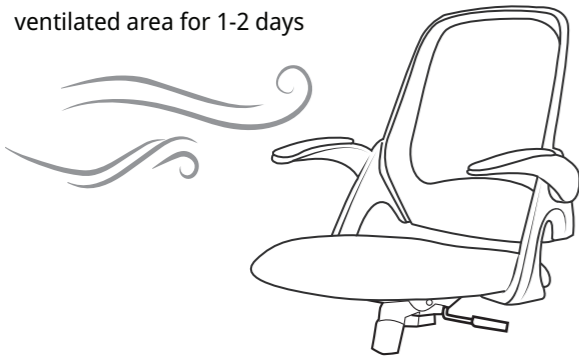

For longer use

Re-tighten bolts every 6 months by using the enclosed allen-key.
*Using an electric drill can damage the chair.
Please re-tighten bolts manually.

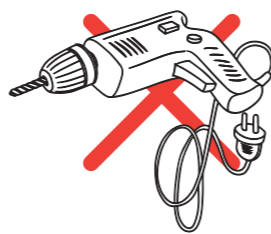
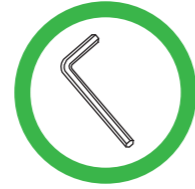

• Cautions

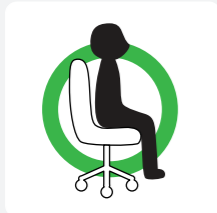

Use this product only for seating **one person** at a time



DO NOT use the chair unless all bolts, screws and knobs are tight



DO NOT use the chair if only components are missing or damaged



DO NOT stand on the chair use as a step stool or ladder

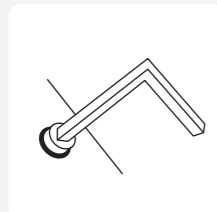

Regularly check all bolts, screws, and **knobs are tight**



Be careful, some of the part are **heavy** and has **sharped edge**



Failure to follow these warnings may cause **serious injury**

If there are any problems, do not hesitate to e-mail us. support@neochair.com

Enjoy your new favorite chair

Our goal is to create a perfect customer experience.
Let us know if you have any feedback.
Your comment motivates us to become a better team.



support@neochair.com

www.neochair.com

[@NEOCHAIR](https://www.facebook.com/NEOCHAIR)

[neochair_office](https://www.instagram.com/neochair_office)

NEC ASSEMBLY INSTRUCTION

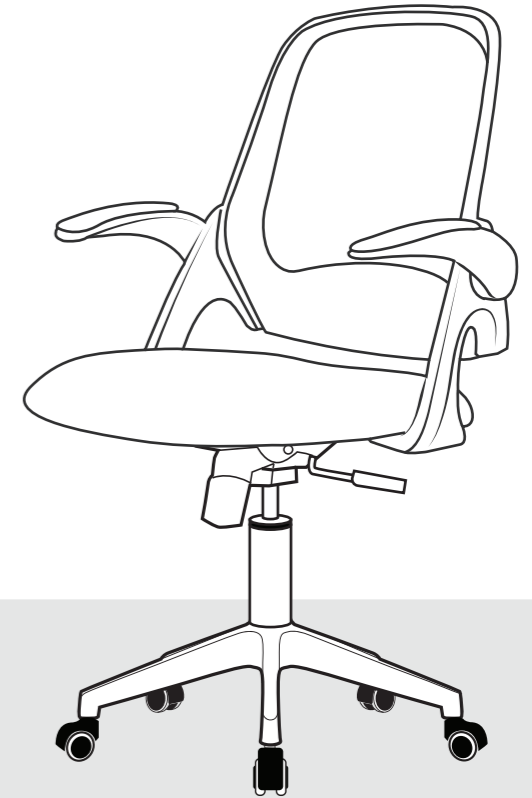

Contents

- Instructions
- User Manual
- Cautions

support@neochair.com

www.neochair.com

※Please make sure all the parts are included.

Missing parts? support@neochair.com

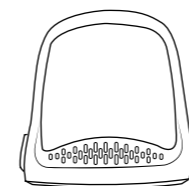

BACK X1

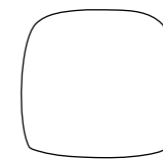

SEAT X1



ARMREST X2

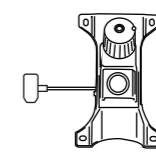

CONTROL MECHANISM X1



WHEEL X5



BASE X1
BASE LEG X1



GAS LIFT CYLINDER X1

- A** X10 (SEAT + BACK ARMREST)
- B** X4 (LOCKING)
- C** X10 (WASHER)
- D** X1 (ALLEN KEY)

Read the instructions carefully.



Please follow the assembly steps.

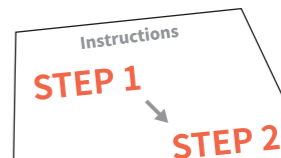

• Instructions

※ NOTICE

Please use the allen key included instead of an electric drill.



TIPS!

Use the box for an easier assembly.

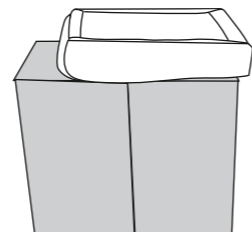

STEP 1 Bottom

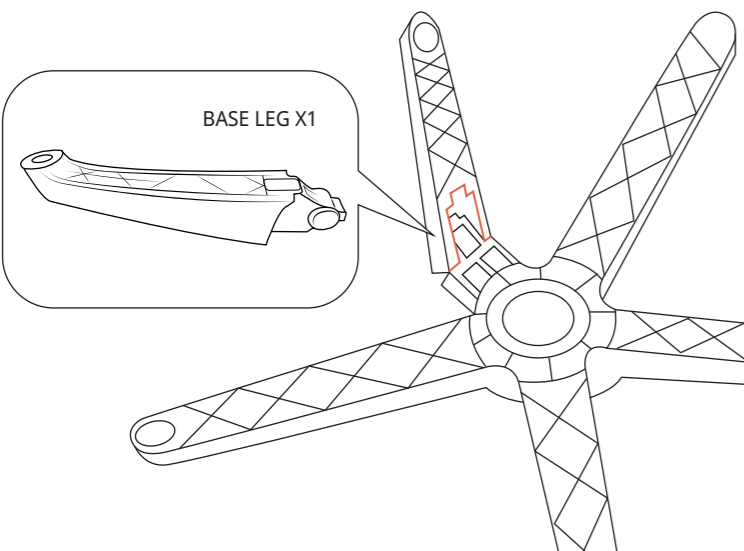

1. Insert the base leg vertically into the base.

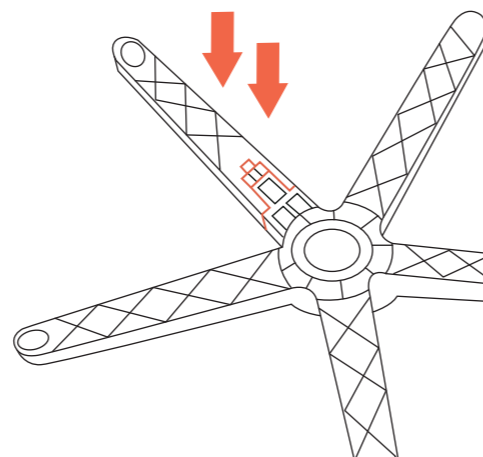

2. Press the base leg until you hear "CLICK."

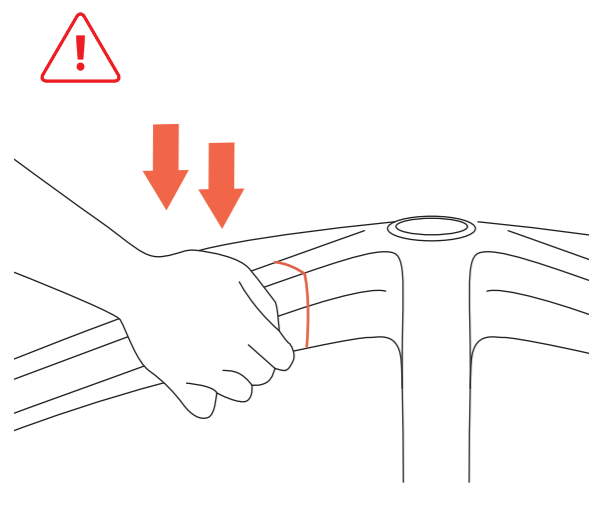

Ouch! Be careful not to get your hands caught in the gap.

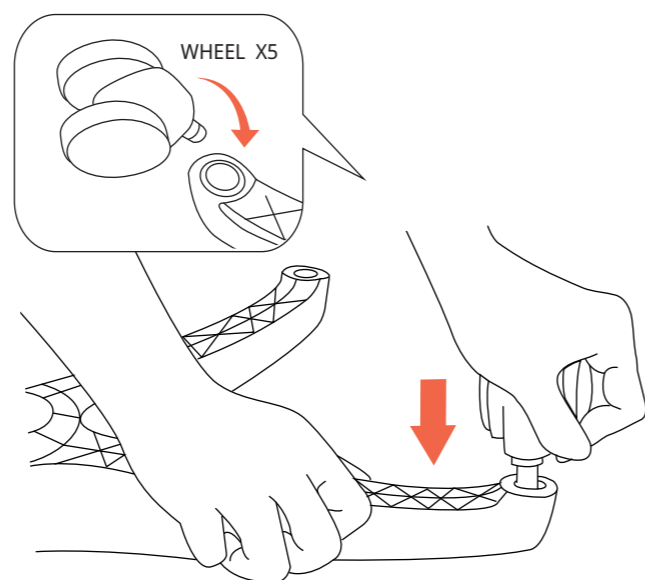

3. Fix the base leg with one hand and insert five wheels into the base.

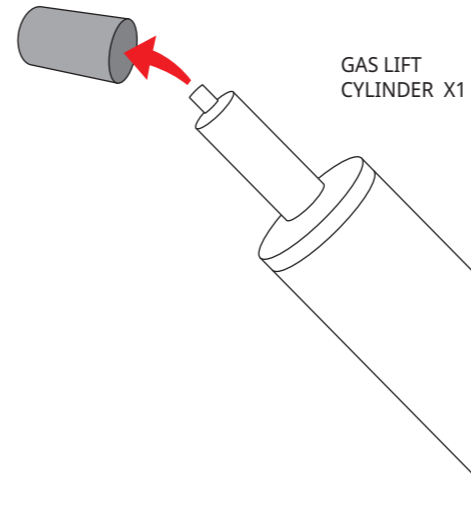

4. MAKE SURE TO REMOVE THE GAS LIFT CAP

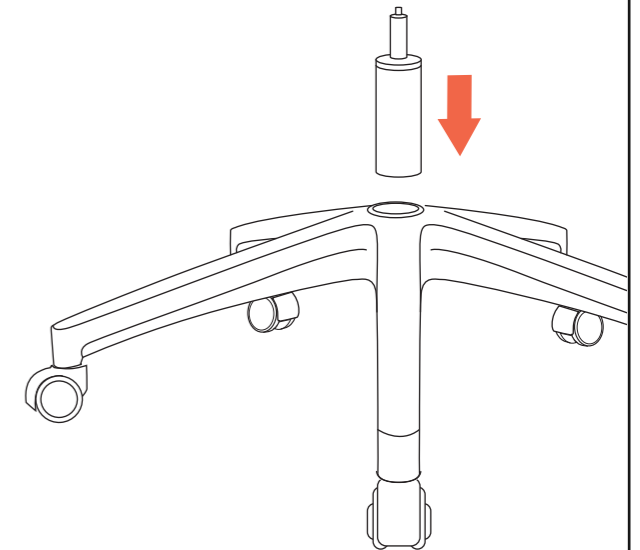

5. Insert gas lift cylinder into the center of the base.

STEP 2 Top

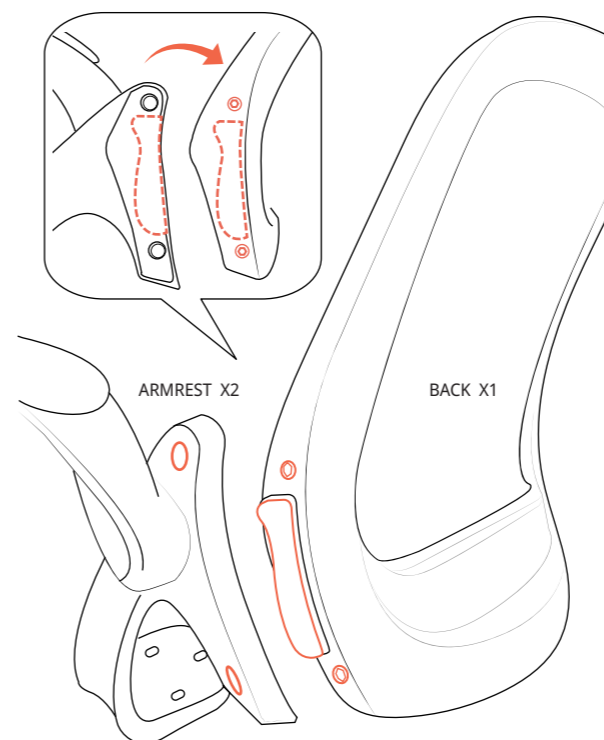

6. Line up the armrest and the back

For proper alignment: Slightly **under-tighten** the bolts.

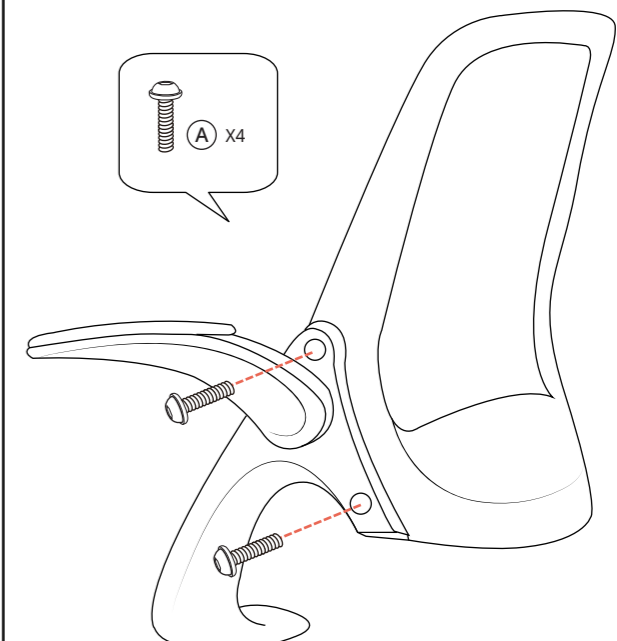

7. Loosely tighten with two bolts. Repeat on the other side.

⚠ For proper alignment:
Slightly **under-tighten** the bolts.

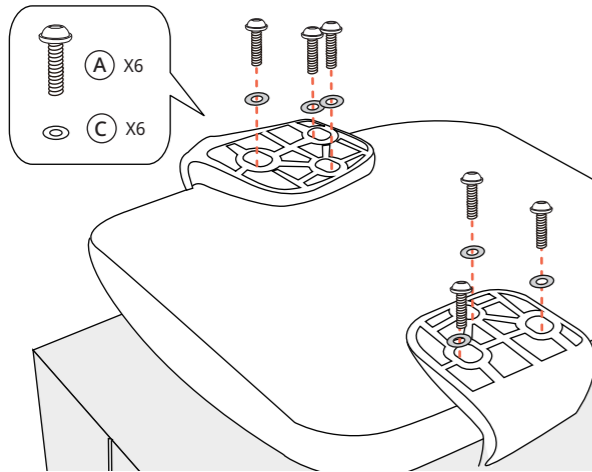

8. Put the armrest on the bottom of the seat and tighten with three bolts on each side.

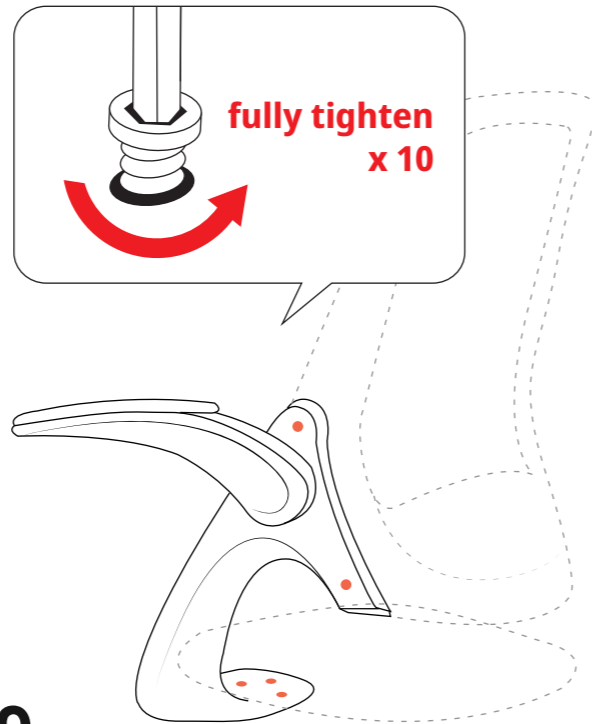

9. Once all of the armrests bolts are in place, **fully tighten** every bolt.

• User Manual

Check

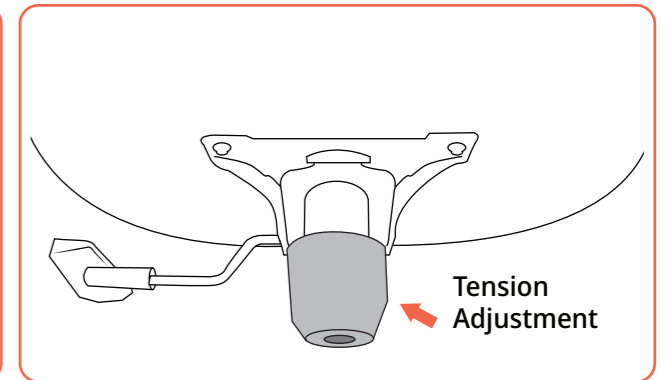
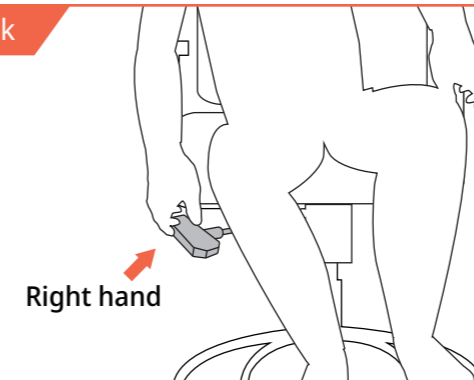

Tilt

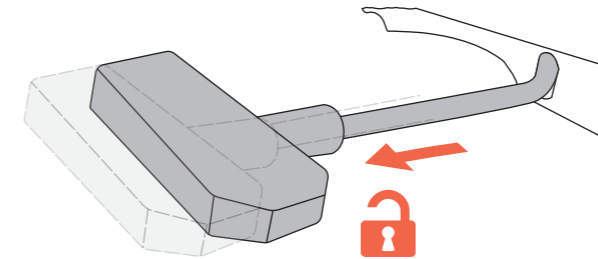

Tilt Lock

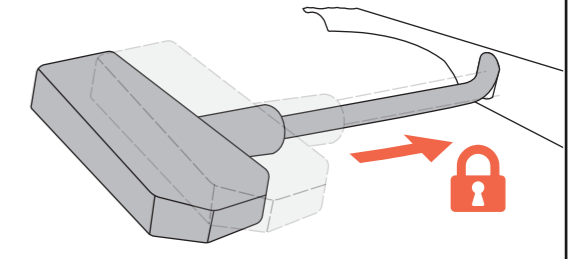

Tilt Tension

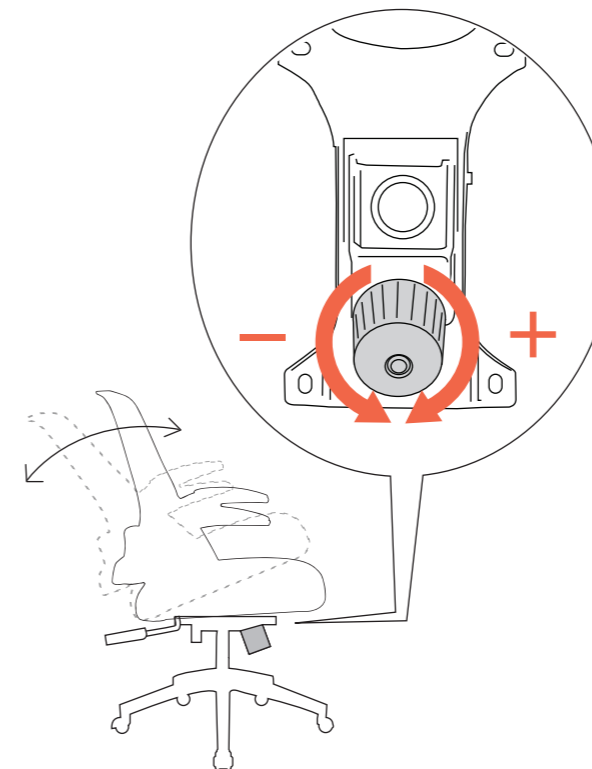

Height

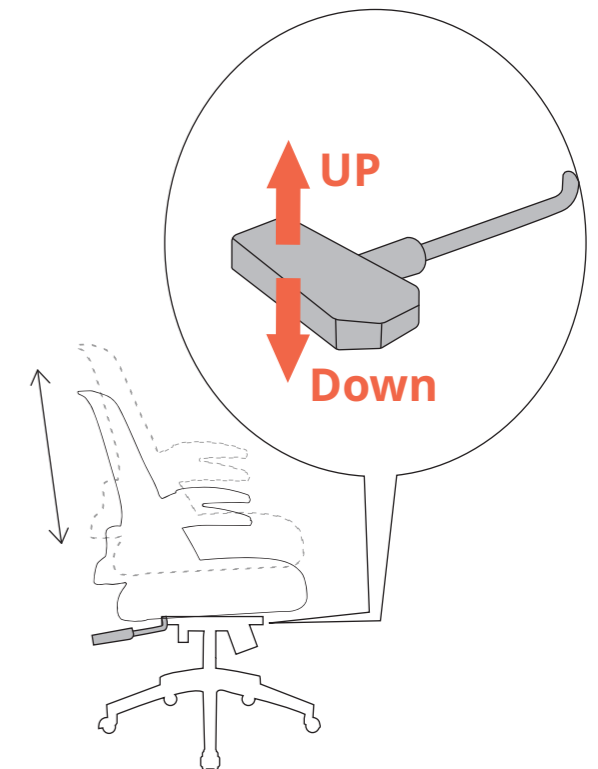

FRONT

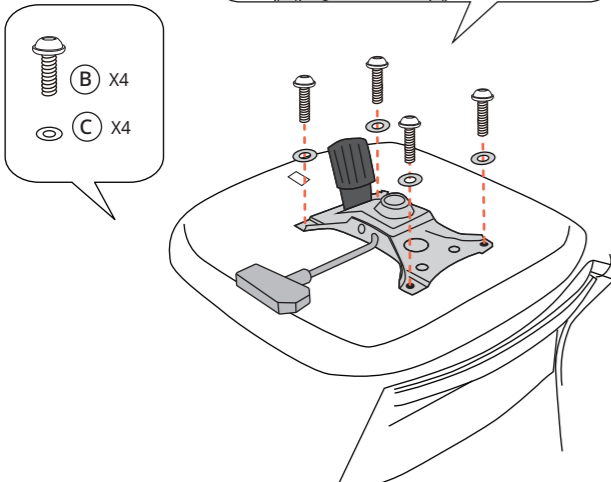

10. Match the front stickers and secure the Control Mechanism to the seat.

STEP 3 Top + Bottom

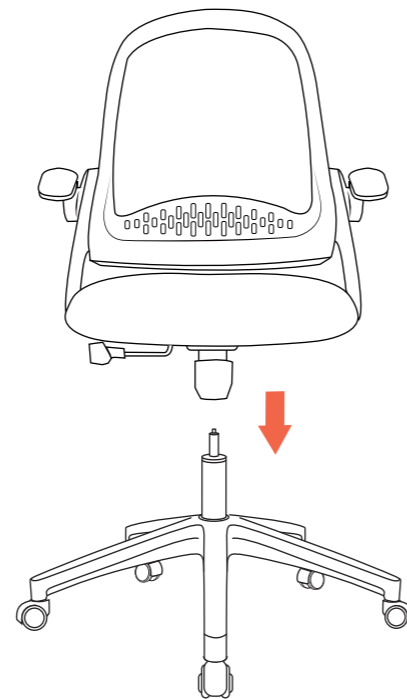

11. Mount the seat onto the gas lift cylinder