

# USER'S MANUAL

## Smart Cat Litter Box

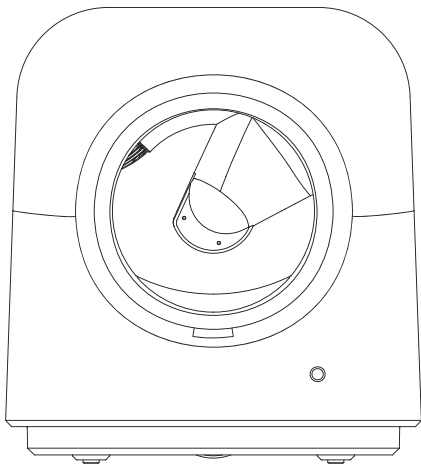

Before using the product, please read the instructions carefully and keep them properly.

## Precaution for Use

---

Please read this product manual thoroughly before use. By installing or using this product, you acknowledge that you have read and agree to the safety instructions contained herein. Our company is not liable for any accidents or losses resulting from improper or incorrect use of the product. The right to interpret and amend this statement is reserved by our company.

### WARNING

- Do not handle the power adapter with wet hands when plugging in or unplugging.
- If you notice any abnormalities with this product, immediately cease use and unplug the power adapter.
- To ensure safe operation, this product should only be used indoors and kept away from ignition sources, high-temperature areas, or direct sunlight exposure.
- Protect the product from potential damage by ensuring pets do not bite the wires, which could lead to electrical leakage. It is the responsibility of the pet owner to ensure the wires are safeguarded from pets.
- Maintain a safe distance from other electrical equipment when using this product to prevent damage due to accidental water splashes.
- Unauthorized disassembly or repair of this product is prohibited, as it may lead to injury or malfunction.

## Precaution for Use

---

### CAUTION

- Avoid placing this product in high areas to prevent falls that could cause damage to the product or pose safety risks to pets.
- To prevent pets from knocking over the product, it is advisable to position it in a corner or against a wall.
- Ensure the device is kept level and stable. Tilting or overturning it may lead to malfunctions.
- If children are operating this device, adult supervision is required.
- Only authorized maintenance personnel should repair this product to prevent the risk of various unexpected injuries.
- Do not exceed the maximum cat litter level indicated by the (MAX) line.
- We recommend using tofu, mixed, or clumping cat litter with this product.
- The top cover and cat litter drum of this product are water-washable. For other components, especially those with electrical parts, only use a cloth to wipe and dry the surface.
- Place the machine on a flat and solid surface. Avoid flexible materials like carpets or uneven surfaces, as these may impact the machine's normal operation.
- Prolonged use of this product in areas with strong magnetic fields is not recommended, as it may interfere with device functionality.

## Parts Information

---

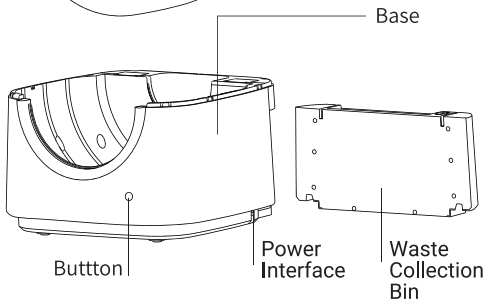
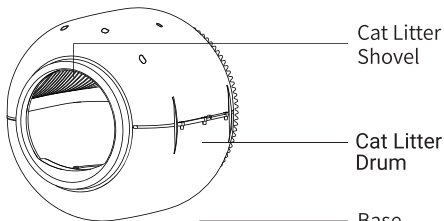
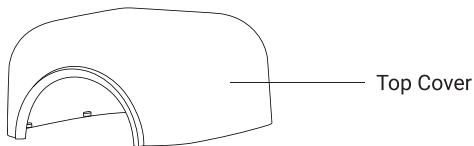

## Instructions For Use

---

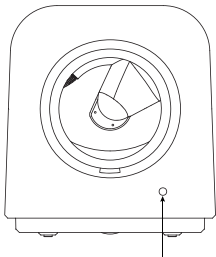

Long Press / Click / Double-click Button  
Perform Operations

### ● ON/Standby Mode

After connecting to the power supply and switching it on, the machine initiates and enters standby mode, indicated by a steady green light. If it's the first time you're using the app, it will prompt for network configuration (the green light will flash rapidly). Once the network setup is complete, press the button, and the green light will remain steadily lit, indicating the machine is in standby mode.

### ● Long Press (APP Version)

Press and hold the button for 10 seconds to reset to factory settings. The device will then enter the network pairing mode and await network configuration.

### ● Single Click

Press the button once to manually initiate the cleaning mode. **Cleaning Mode:** This mode cleans cat's waste and large clumps of cat litter in the drum, moving them to the collection bin.

### ● Double Click

Double-click the button to manually start the cat litter disposal mode. **Cat Litter Disposal Mode:** This mode removes all waste litter from the drum into the waste collection bin.

### ● Button Light Control (APP Version)

To turn off the button light, go to the APP settings and select 'Indicator Light' to disable it.

# Instructions For Use

---

## 1. Removing the Waste Collection Bin:

Depending on your preference, the waste collection bin can be removed from either the left or right side.

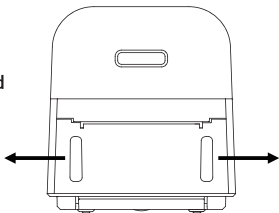

## 2. Installing Trash Bag and Aromatherapy Tablet:

### ● Trash Bag Installation:

As illustrated, first remove the cover of the waste collection bin. Insert the trash bag into the bin's groove, then reattach the cover. Press down on the trash bag firmly to ensure it's securely installed.

### ● Aromatherapy Tablet Installation:

Open the aromatherapy tablet package and insert the tablet into the groove on the toilet cover.

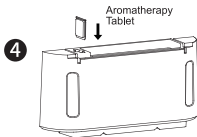
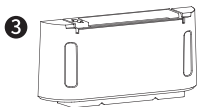
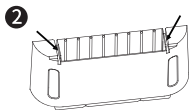
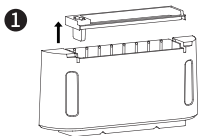

# Instructions For Use

---

## 3. Installing the Waste Collection Bin into the Base:

Place the waste collection bin back into the base and align it centrally.

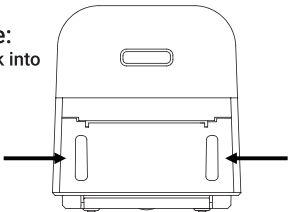

## 4. Inserting the Power Adapter:

Plug the power adapter into the power port on the base. The machine will automatically power on and enter standby mode.

**\*APP Version Note:** When the device is powered on for the first time, it enters the network distribution mode. This is indicated by a rapidly flashing green light, signaling that the device is waiting for network connection setup by the user.

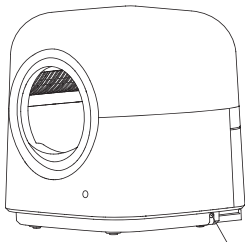

Wall Outlets



AC adaptor  
(included)

# Instructions For Use

## 5. Adding Cat Litter

We recommend filling the cat litter up to the MAX marking line, which is located at the top of the TPR cat litter holder. After adding cat litter, the machine will display a blue light for about 5 minutes. This will be followed by a green light, indicating that the machine is automatically leveling the litter.

(Note: A low level of cat litter increases the likelihood of the drum sticking to the wall. Please replenish the cat litter promptly.)



## 6. Starting the Machine

The machine offers both standalone and networked operation modes.

**1. Standalone Mode:** After powering on and adding cat litter, the machine will automatically enter standalone mode. In this mode, only the cleaning function is available for automatic operation, and the sterilization function is not accessible.

**2. Networked Mode (APP Version):** Follow the provided instructions for network configuration. Once connected, the machine can be fully controlled and operated through the APP.

### APP Control

#### ● Downloading and Installing the APP:

- Search for "TUYA Intelligence" in major mobile application stores to download and install the app.
- After installation, register for an account and log in to the APP.

#### ● Device Setup:

- Open Bluetooth and WiFi on your phone.
- On the homepage, click on "ADD DEVICE".
- Ensure the smart cat litter box is in the network configuration state (indicated by a flashing green light).
- Follow the APP prompts to bind the device.

Note: Due to possible upgrades and updates to the APP, the actual operation may slightly differ from the above description. Please follow the instructions in the current version of the APP for operation.

### Entering Network Pairing Mode

To initiate network pairing, press and hold the button on the device for 10 seconds. The green light will begin to flash quickly, indicating that the machine has entered the network pairing mode and is ready to connect to the network.



# Network Setup Guide for APP-Controlled Version



1. Open the "TUYA Intelligence" APP. Register and log in.

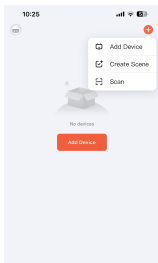

2. Click the "+" icon in the upper right corner, then select "Add Device".

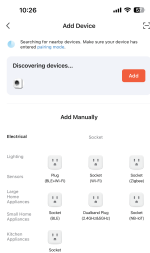

3. Once the APP discovers the device, click "Add" (ensure the machine is in the Pairing Mode with the green light flashing rapidly).

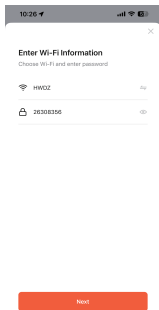

4. Enter your 2.4GHz WiFi network name and password.

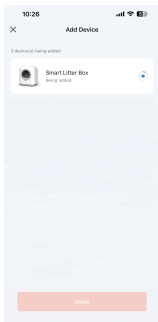

5. Wait for the device to be successfully added to the network.

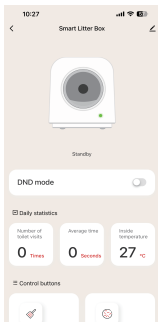

6. Once completed, proceed to the main page.

## Cleaning Instructions

---

### • Cat Litter Drum Cleaning

Before cleaning the drum, use the “remove cat litter” function in APP to remove all cat litter inside. (Or double-click the button to start cat litter disposal mode without APP)

The disassembly instructions for the drum are illustrated in the figure. The drum can be detached after removing the upper cover. Wipe the drum with a damp towel or wash it with water.

After cleaning, ensure the drum is completely dry before placing it back into the base for use.

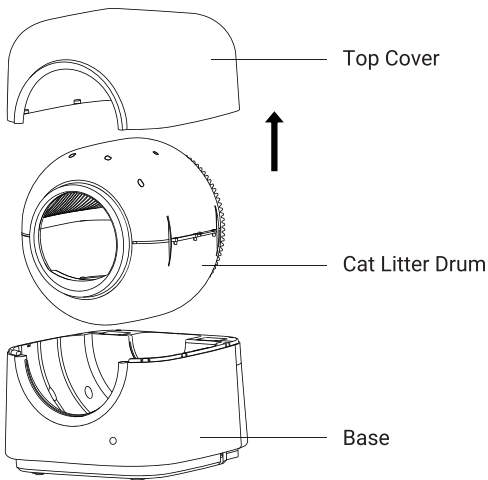

**Note:** When placing the cat litter drum back into the base, precise alignment is not necessary. The machine will automatically rotate and return the drum to its original position after placement.

# Sterilization Instructions (APP-Controlled Version)

## • Sterilization Instructions

The sterilization mode is accessible exclusively through the APP and includes both manual and smart sterilization options.

**1. Manual Sterilization:** Tap the "Sterilization" button in the APP. The UV sterilization module will initiate a 10-minute sterilization cycle for the waste collection bin. The process will automatically conclude upon completion.

**2. Smart Sterilization:** Enable this feature in the APP under 'Smart Sterilization' in the settings. Once activated, the sterilization process will automatically occur for the collection bin every 6 hours, lasting 10 minutes for each cycle. The process will automatically terminate after completion.

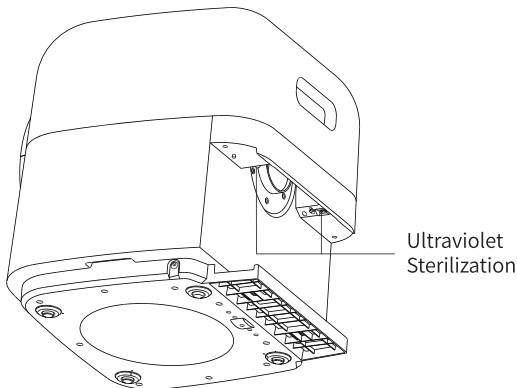

**Note:** The UV sterilization module is situated above the waste collection bin. It is important not to open the upper cover or the waste collection bin during the sterilization process, as doing so will terminate the sterilization cycle.

# Indicator Status and Troubleshooting Guide

## Indicator light Status

## Working Status

Steady green light

Machine standby /cleaning /cat litter removing

Green light flashes rapidly  
(APP version)

Device prompts for network setup

Steady red light

1.The upper cover and waste collection bin are not properly installed, or the cleaning process has been interrupted."  
2.The waste collection bin is full and needs to be emptied.

Red light flashing

The motor stops running due to excessive resistance.

Steady blue light

Machine detects cat entering or cat litter being added.

Steady purple light(APP version)

UV sterilization in process.  
(Each sterilization cycle lasts for 10 minutes)

| Fault Description                                      | Treatment measures   |
|--|--|
| Steady Red light                                       | <ol style="list-style-type: none"><li>1. Check if the top cover or waste collection bin is properly installed."</li><li>2. Verify if the machine is in the process of cleaning or cat litter removing and if a cat has approached or entered the machine. If so, the machine will complete the remaining program and return to a steady green light after the cat leaves."</li><li>3. Check if the waste collection bin is full. If it is, please clean it out."</li></ol> |
| Red light flashing                                     | <ol style="list-style-type: none"><li>1. Disconnect the power, open the top cover, remove the drum, and check for any foreign objects in the gears. After ensuring there are no abnormalities, reinstall the drum, reconnect the power, and run the machine.</li><li>2. Confirm whether the cat litter exceeds the MAX marking line. If it does, remove a portion of the cat litter to reduce it to the appropriate level."</li></ol>                                      |
| Unable to connect to WiFi                              | <ol style="list-style-type: none"><li>1. Check if the WiFi name or password is correct.</li><li>2. Verify if the WiFi frequency is 2.4GHz. If the WiFi frequency is 5GHz, please try with a different router that supports 2.4GHz."</li></ol>  |
| The cat waste easily adheres to the drum's inner wall. | Ensure there is sufficient cat litter and add more up to the MAX line if needed.   |

Tip: If the above measures do not resolve the issue, please contact customer service at: [service@petfamily365.com](mailto:service@petfamily365.com).

## Packing list

---

|                          |                                 |
|--------------------------|---------------------------------|
| Smart Cat Litter Box / 1 | User's Manual / 1               |
| AC adaptor / 1           | Trash Bag / 2 rolls (40 pieces) |
| Aromatherapy Tablets / 4 | Sand leakage pad / 1            |

### Product Spec.

Product Name: Smart Cat Litter Box

Product Size: 545X545X595(H) mm

Rated Capacity: Approximately 60L

Weight: 13.5kg

Input: DC 12V 2A

## YUMENG INFO-TECH (SUZHOU) CO., LTD.

Add: Room 501, 5th Floor, Building E3, Artificial Intelligence Industrial Park, No. 88 JinJiHu Ave., SIP, China (Jiangsu) Pilot Free Trade Zone Suzhou Area

Tel: 0086-512-67999996

Website: [www.petfamily365.com](http://www.petfamily365.com)

Email: [service@petfamily365.com](mailto:service@petfamily365.com)

MADE IN CHINA



# Warranty

The warranty period is one year. During this time, warranty service is only available at designated brand service centers.

1. When seeking warranty service, please present the order receipt and this warranty card.
2. The following warranty terms apply from the date of purchase under normal use conditions:

- a. Complimentary repair within one year for the entire device.
- b. Main components such as the motor, circuit board, and adapter are covered under a one-year complimentary warranty.

This warranty only applies to consumers who purchase the product for personal and household use, not for business or commercial purposes.

Even within the warranty period, the following cases are not eligible for complimentary warranty service, but paid repair services may be available:

- a. Damage due to failure to use, maintain, or store the product as specified in the instruction manual.
- b. Damage due to incorrect operation, improper power supply, or physical damage (e.g., from dropping).
- c. Damage caused by repairs not carried out by authorized service personnel.
- d. Inability to present the order receipt and warranty card.
- e. Information recorded on the warranty certificate does not match the product's physical identification or has been altered.
- f. Damage due to force majeure events (e.g., lightning, earthquakes, fires, floods)."