

INSTALLATION INSTRUCTIONS SPLASHBACK

T: 03330153450
E: HELLO@DISPLAYPRO.CO.UK
WWW.DISPLAYPRO.CO.UK
© Displaypro Ltd 2020



Supplied with protective plastic film. Please remove after installation is complete

Caution may contain sharp edges.

May contain marks from manufacture clean with damp cloth with soapy warm water

CARE INSTRUCTIONS FOR STAINLESS STEEL AND ACRYLIC SPLASHBACK

TO MAINTAIN APPEARANCE AND PERFORMANCE OF YOUR NEW SPLASHBACK THE FOLLOWING INSTRUCTIONS AND ADVICE MUST BE FOLLOWED. RETURNS WILL NOT BE ACCEPTED DUE TO DAMAGES FROM INSUFFICIENT CARE, MAINTENANCE OR POOR FITTING.

Storage

Stainless steel and acrylic splashbacks products must be stored either flat or absolutely vertical. Items must be stored at normal room temperature and humidity. The protective film on the stainless steel or acrylic splashback must be undamaged and left intact until installation is finished.

Fitting

Items should be only fitted in normal household ranges of temperature and humidity. Care should be taken in newly built areas to ensure a stable atmosphere. All doors and windows should be in place including fully dried plasterwork and all major work is completed before installation.

Maintenance

Bleach chlorides or common salt and acids of any kind can damage stainless steel or acrylic splashbacks. If spillages happens rinse immediately and thoroughly with water and dry with a soft cloth. Metal objects that may rust should not be on contact with stainless steel splash back. To maintain use warm water and a mild detergent ensuring that the surface is rinsed thoroughly and then dried with a soft cloth.

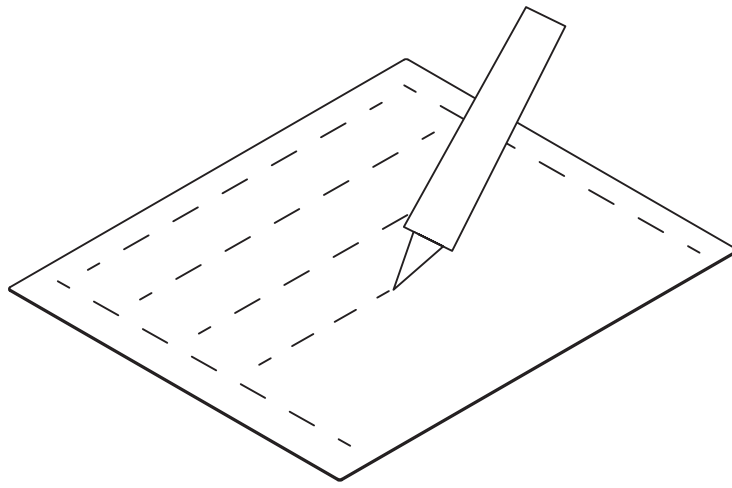

STEP 1:

APPLY SUITABLE GRAB ADHESIVE
TO THE REAR SURFACE OF THE
SPLASH BACK

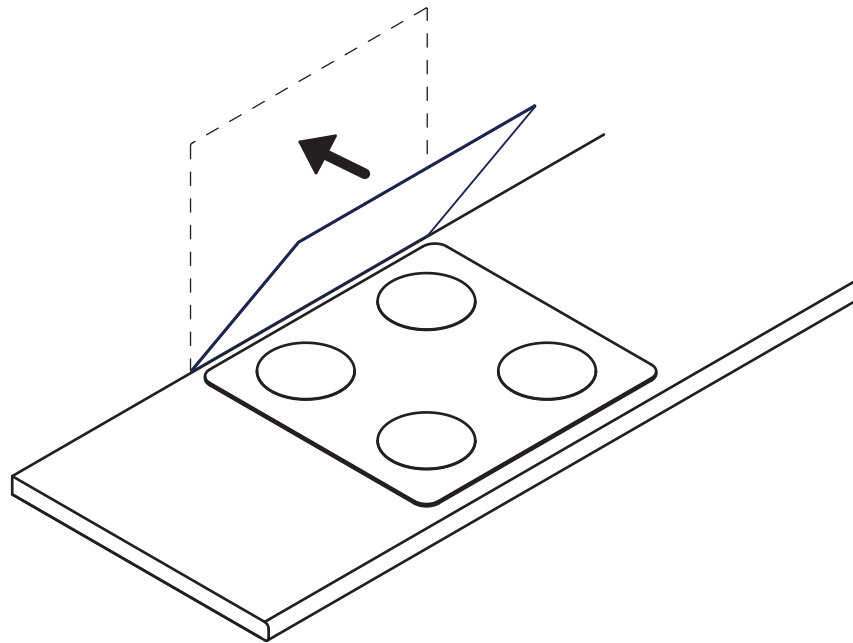

STEP 2:

AFFIX SPLASHBACK TO THE WALL AND PUSH FIRMLY TO ENSURE GOOD
CONTACT BETWEEN THE WALL AND THE ADHESIVE. REFER TO THE ADHESIVE
MANUFACTURE INSTRUCTIONS REGARDING CURING TIME REQUIRED.
SPLASHBACK WILL NEED SUPPORT DURING THIS TIME SO IT DOES NOT SEPARATE
FROM THE WALL.

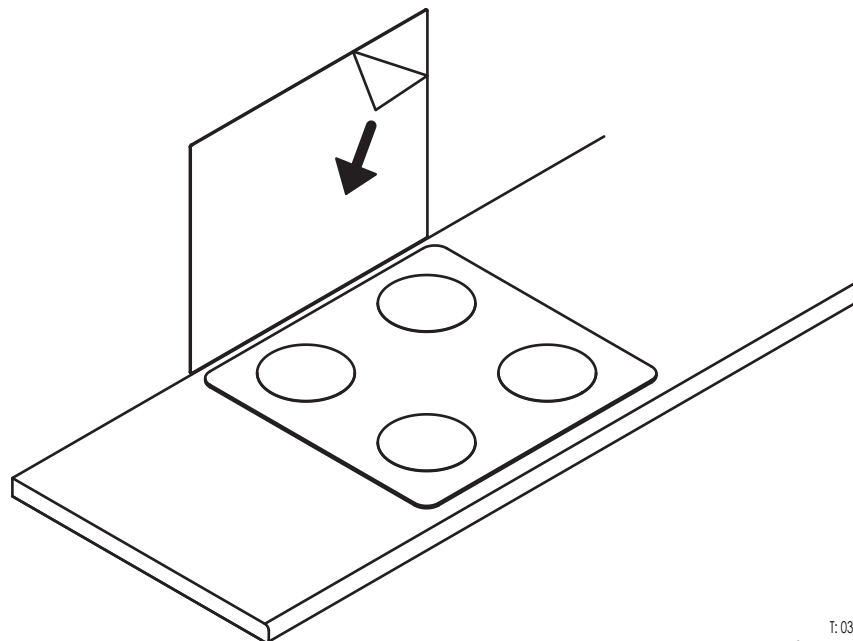

STEP 3:

ONCE ADHESIVE IS CURED AND
DRIED REMOVE THE PROTECTIVE FILM