

IN SITU MODULAR SOFA

— Anderssen & Voll



With the In Situ Modular Sofa, you can choose between 30 predefined configurations or create your own configuration. Scan the QR code to find specific assembly guides for all predefined configurations.

Straight Frame Section Assembly _____ 1
 Straight Frame Section to Module _____ 2
 Straight Frame Section to Multiple Modules _____ 3
 Lower Linking Bracket on Straight Configuration _____ 4
 Upper Linking Bracket on Straight Configuration _____ 5
 Straight Configuration to Straight Configuration _____ 6

Corner Frame Section Assembly _____ 7
 Corner Frame Section to Module _____ 8
 Lower Linking Bracket on Corner Configuration _____ 9
 Upper Linking Bracket on Corner Configuration _____ 10-11
 Corner Configuration to Corner Configuration _____ 12

1 STRAIGHT FRAME SECTION ASSEMBLY

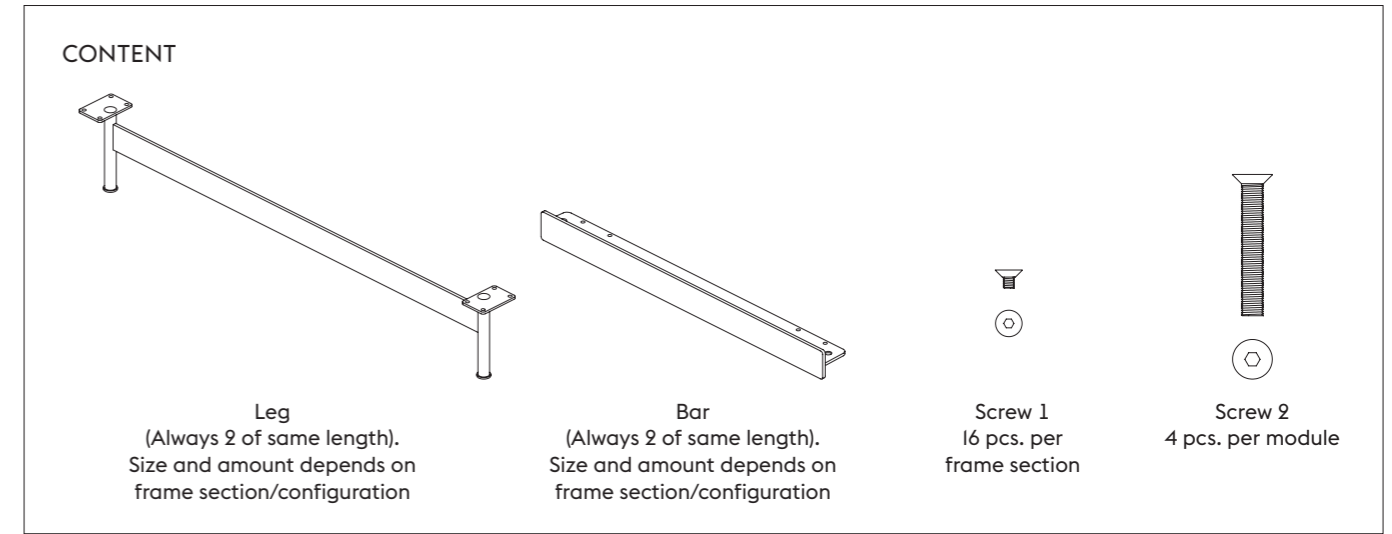

With screw 1, fasten legs to bars
as illustrated.

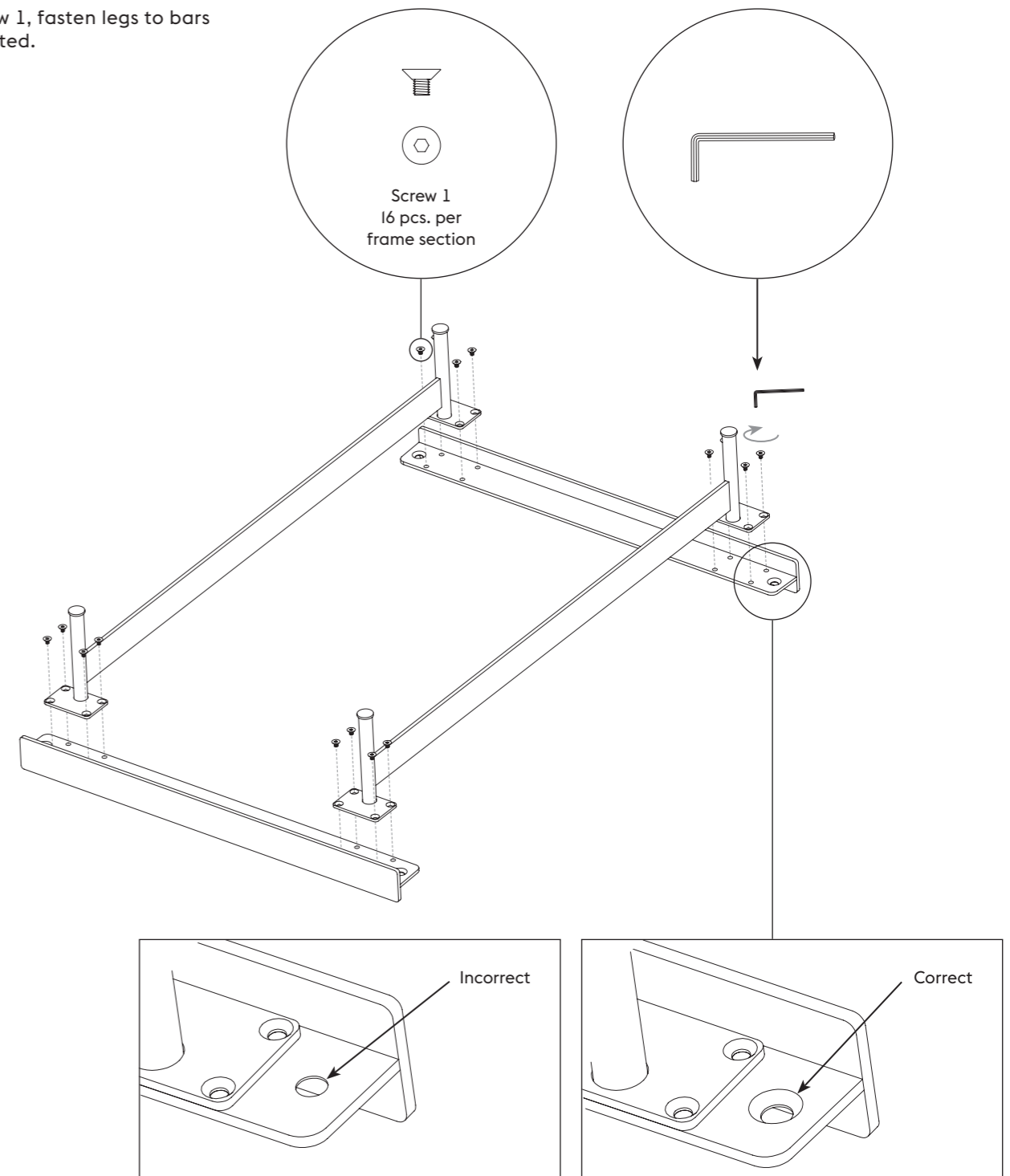

2 STRAIGHT FRAME SECTION TO MODULE

With screw 2, attach the whole frame section to the individual module as illustrated.

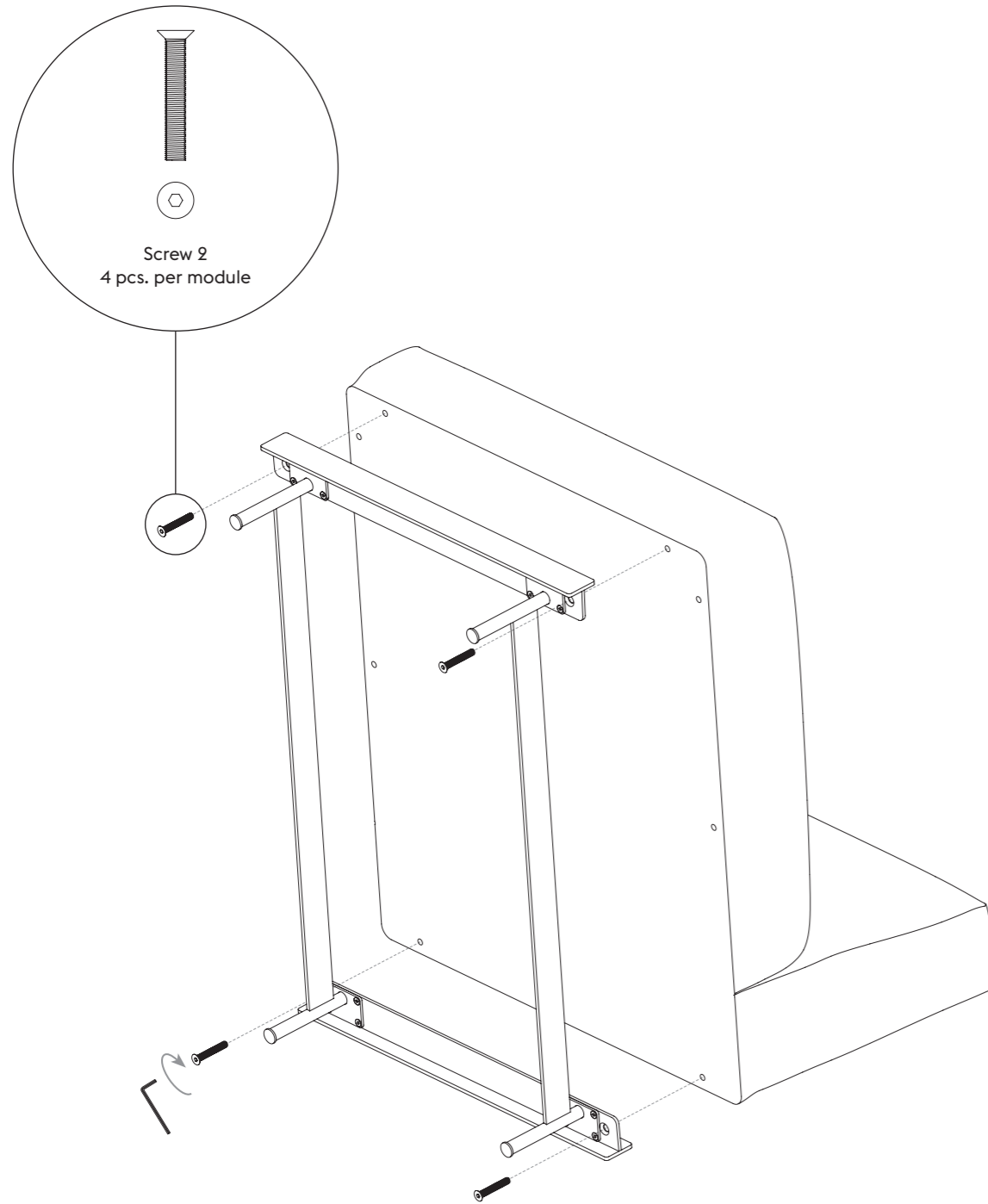

3 STRAIGHT FRAME SECTION TO MULTIPLE MODULES

Starting from one side/end of the frame section attach the individual modules loosely, without leaving any gap in between as illustrated using screw 2.

When all modules are attached, secure the modules by tightening the screws. Each Module is fastened with 4 screws and some holes in bars might not be used.

Number of modules and screws depend on the configuration. Hole pattern in bars depends on the order of chosen modules.

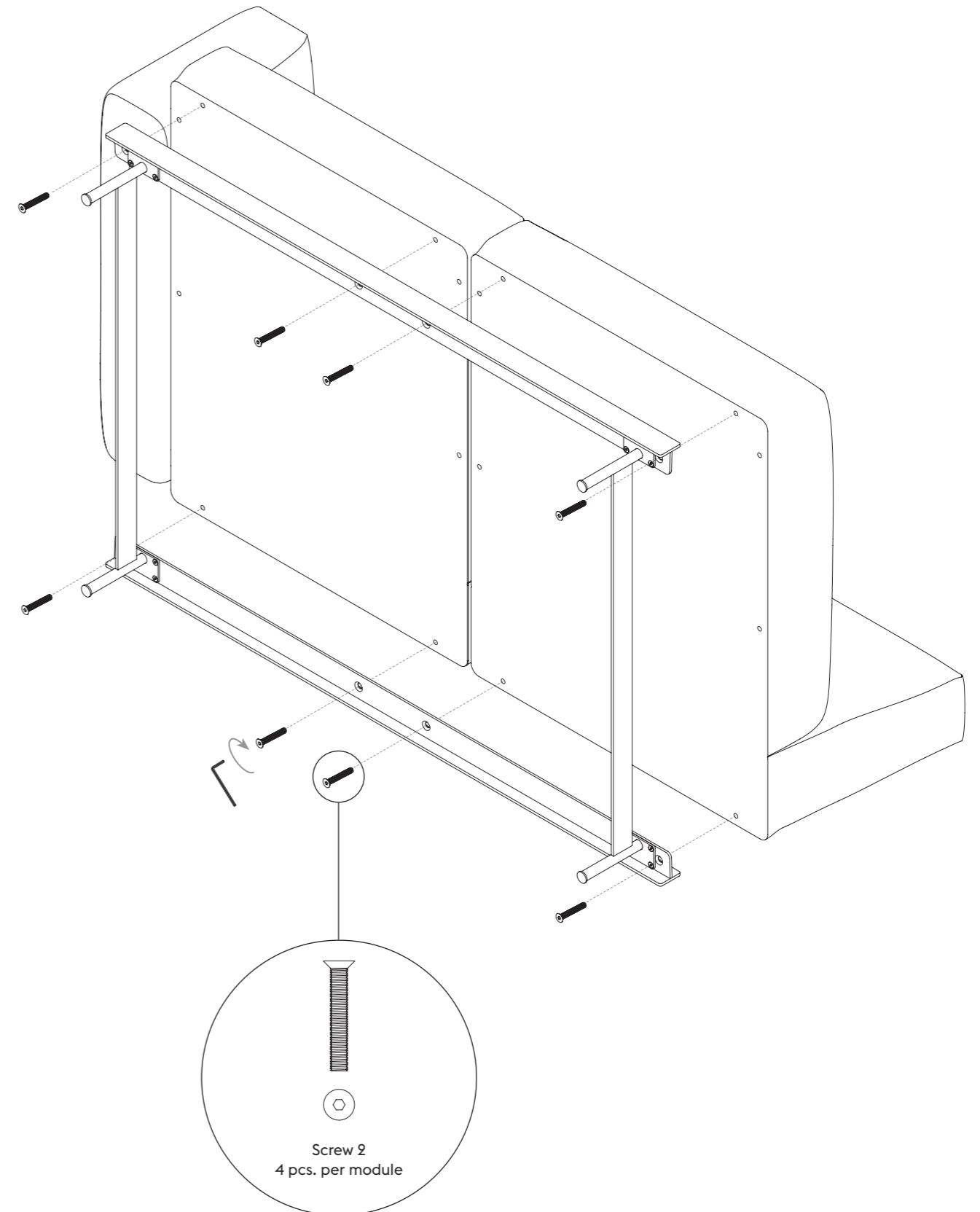

4 LOWER LINKING BRACKET
ON STRAIGHT CONFIGURATION

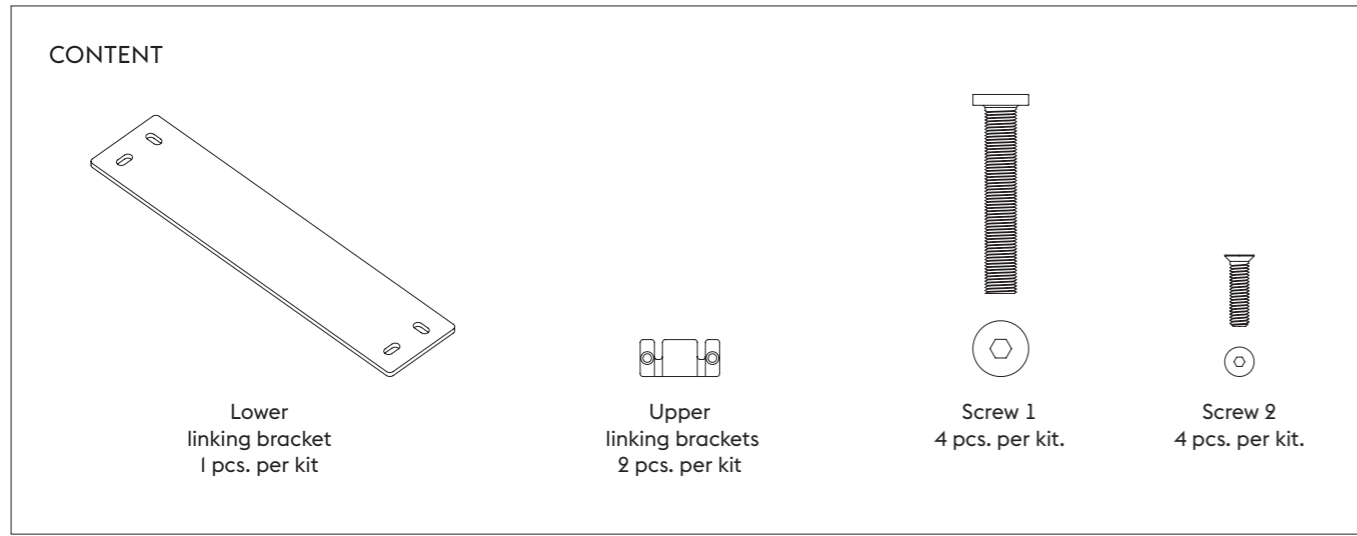

Use screw 1 x 2 to attach the lower linking bracket as illustrated to one fully assembled section.

NOTE — The smallest section, or the section with the fewest modules, should always have the the lower linking brackets attached first.

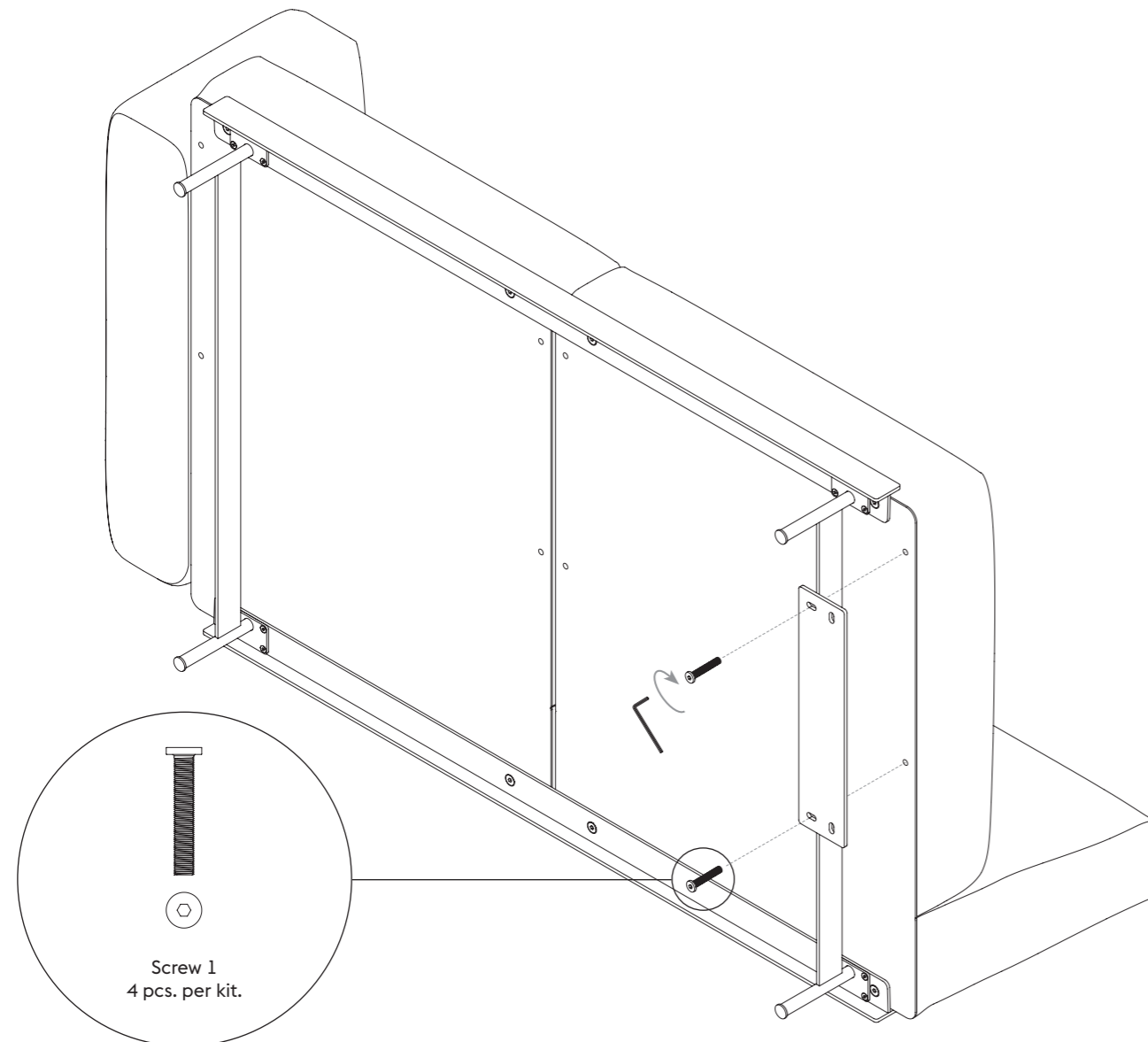

5 UPPER LINKING BRACKET
ON STRAIGHT CONFIGURATION

With screw 2, attach the upper linking brackets as shown. Make sure to always face one up and one down.

NOTE — The smallest section/the section with the fewest modules, should always have the upper linking bracket facing upwards.

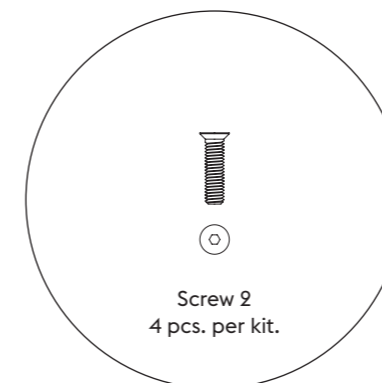
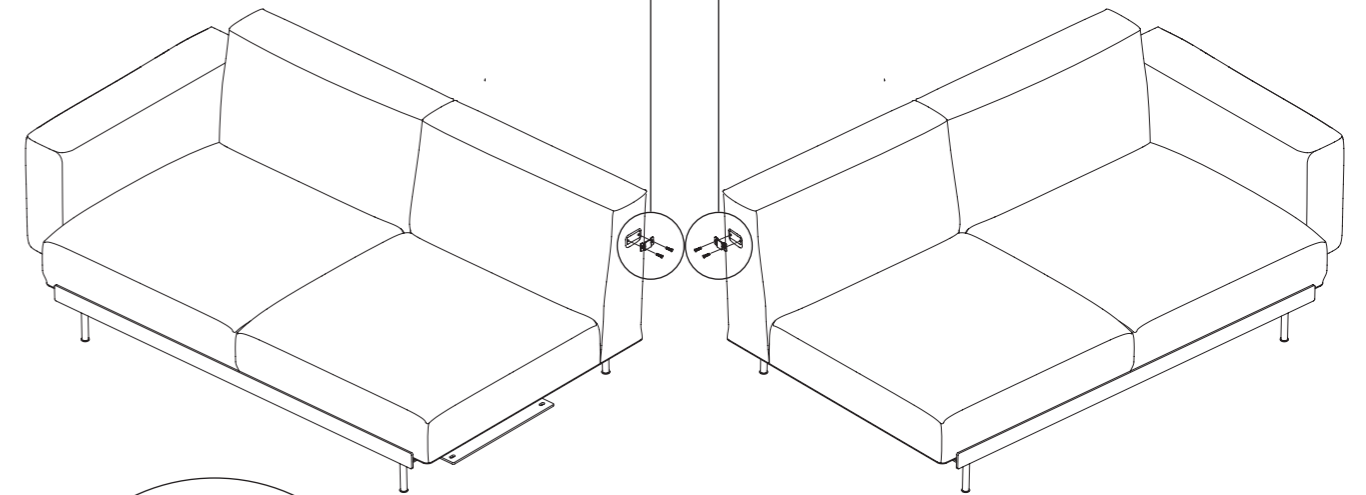
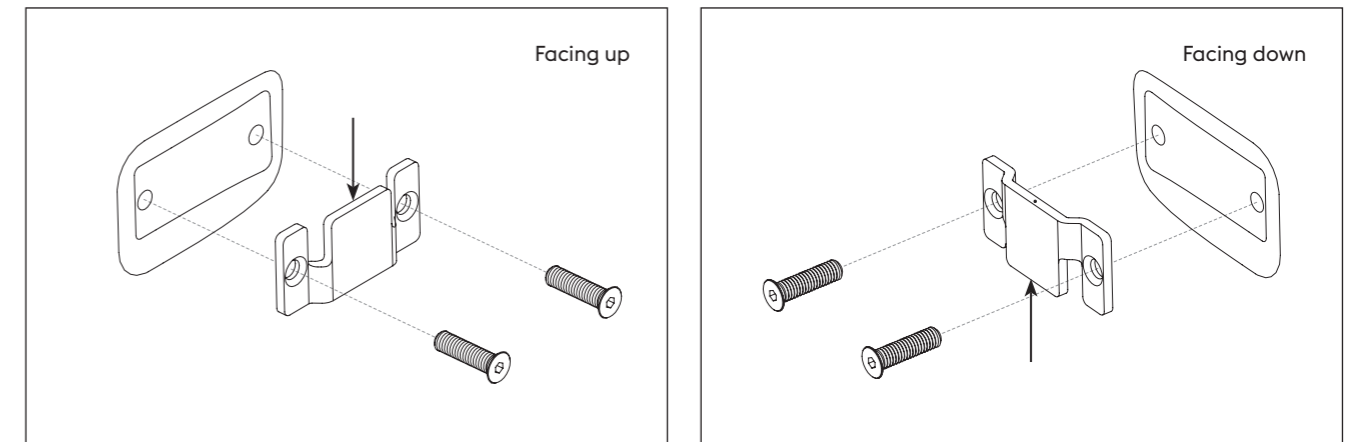

6 STRAIGHT CONFIGURATION
TO STRAIGHT CONFIGURATION

Link the upper brackets as shown, and secure the lower linking brackets with the remaining screws 1 x 2 underneath.

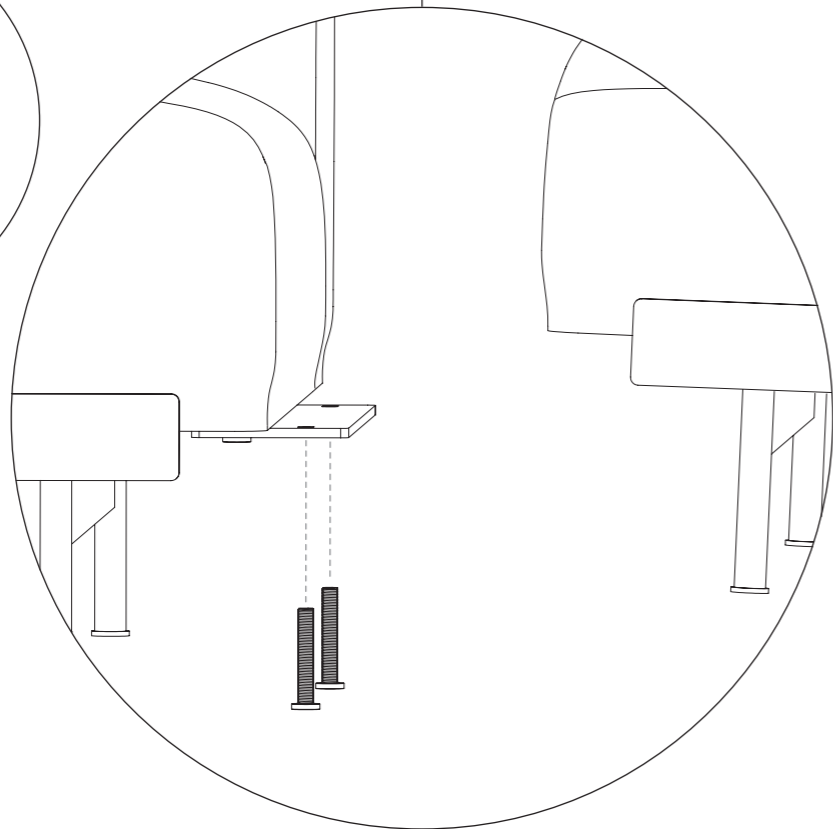
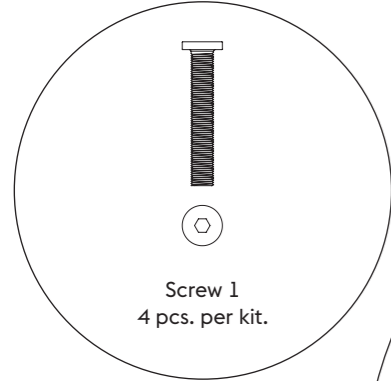
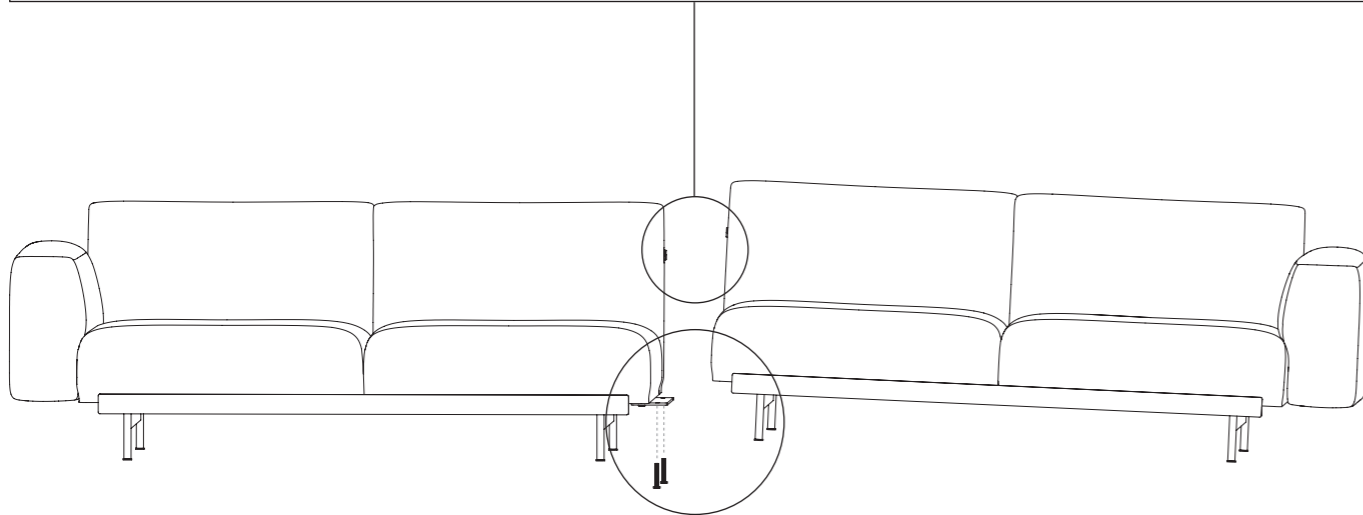
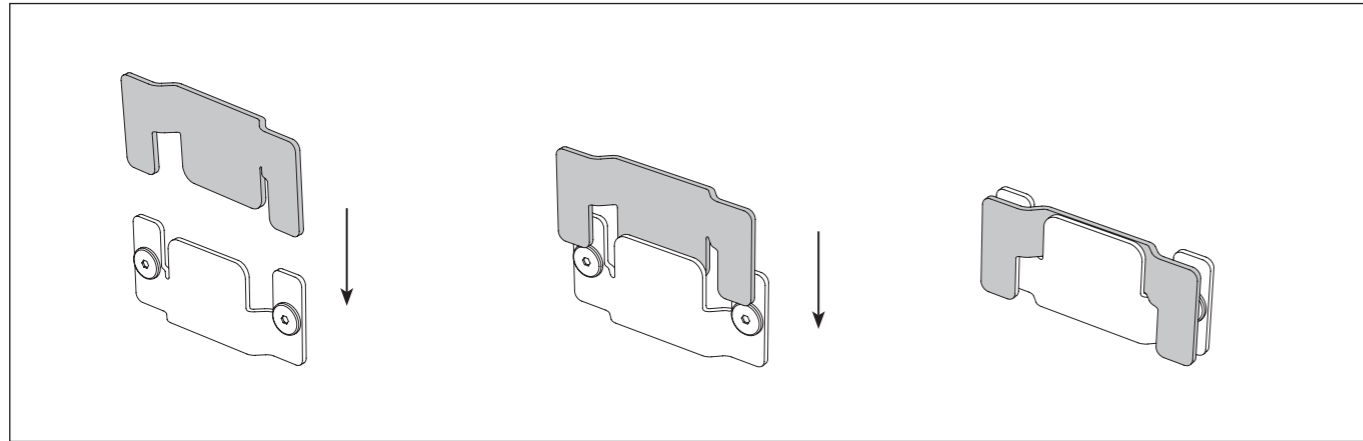

7 CORNER FRAME SECTION ASSEMBLY

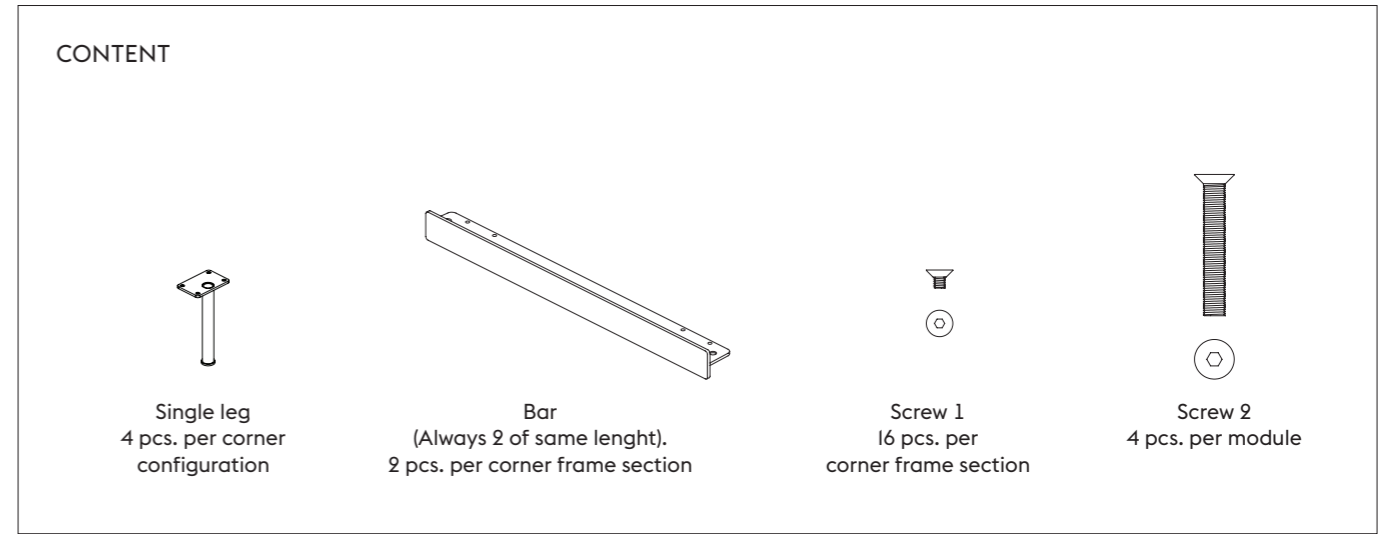

With screw 1, fasten legs to bars as illustrated.

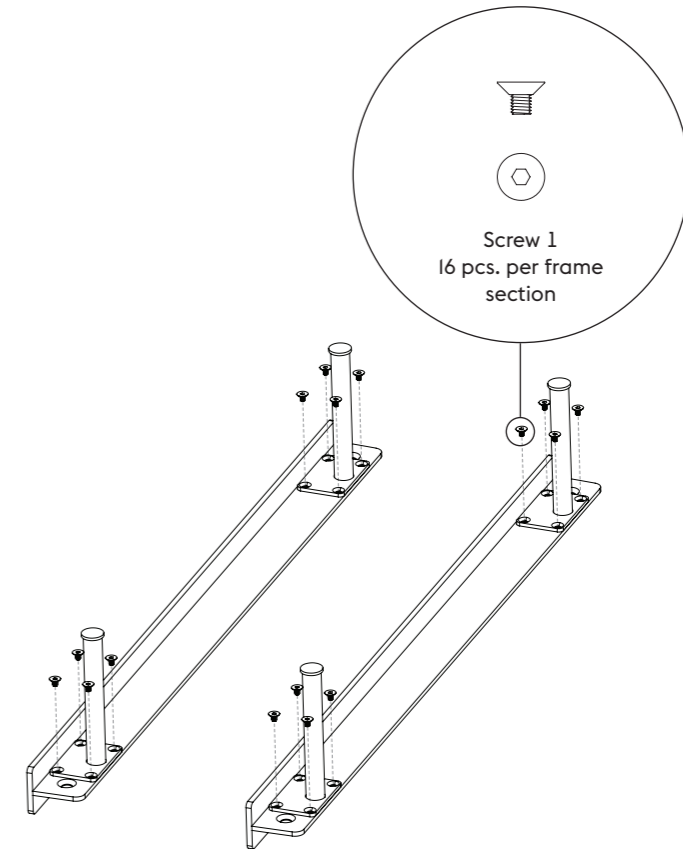

8 CORNER FRAME SECTION TO MODULE

With screw 2, attach the whole frame section to the individual module as illustrated.

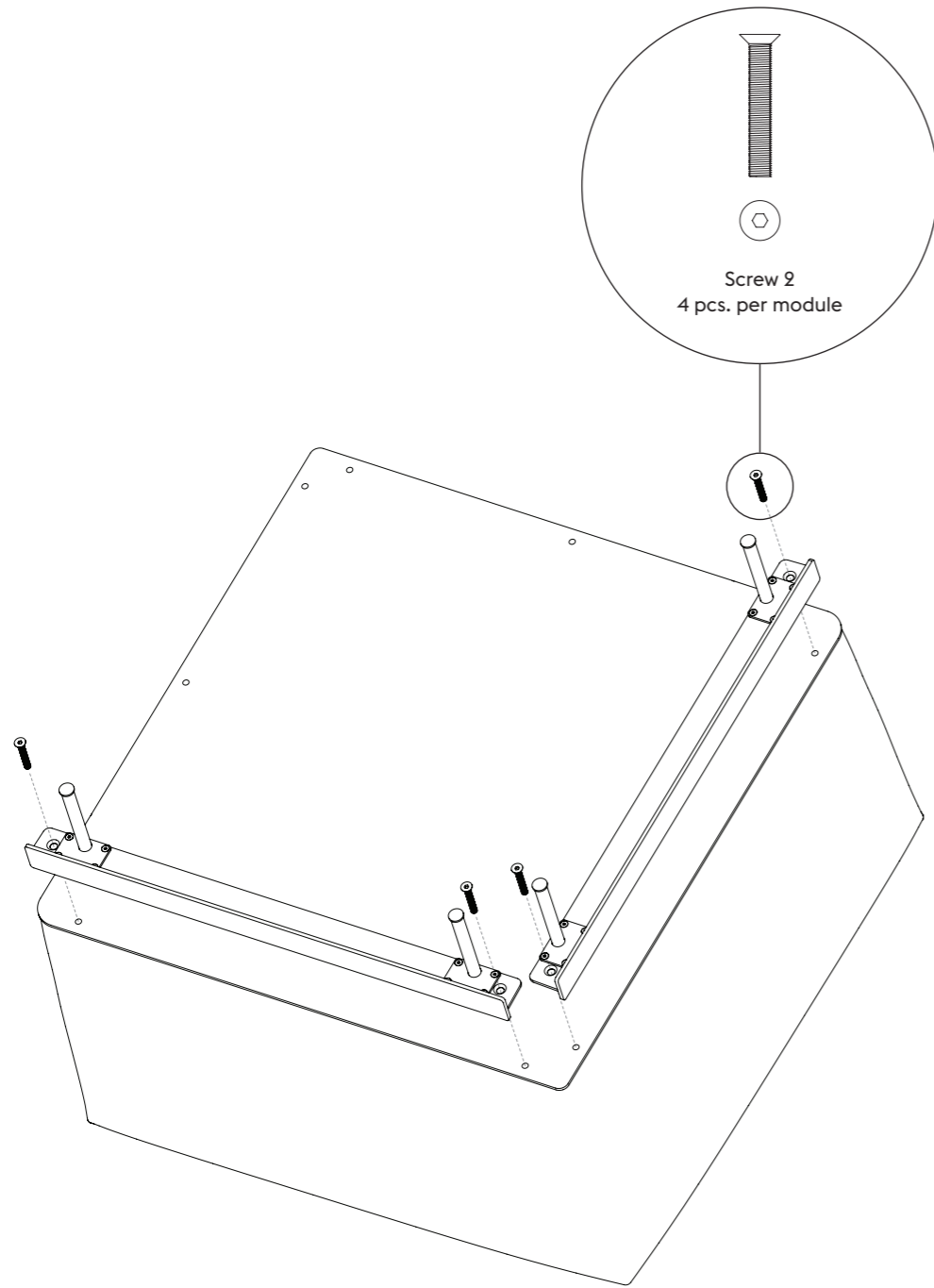

9 LOWER LINKING BRACKET ON CORNER CONFIGURATION

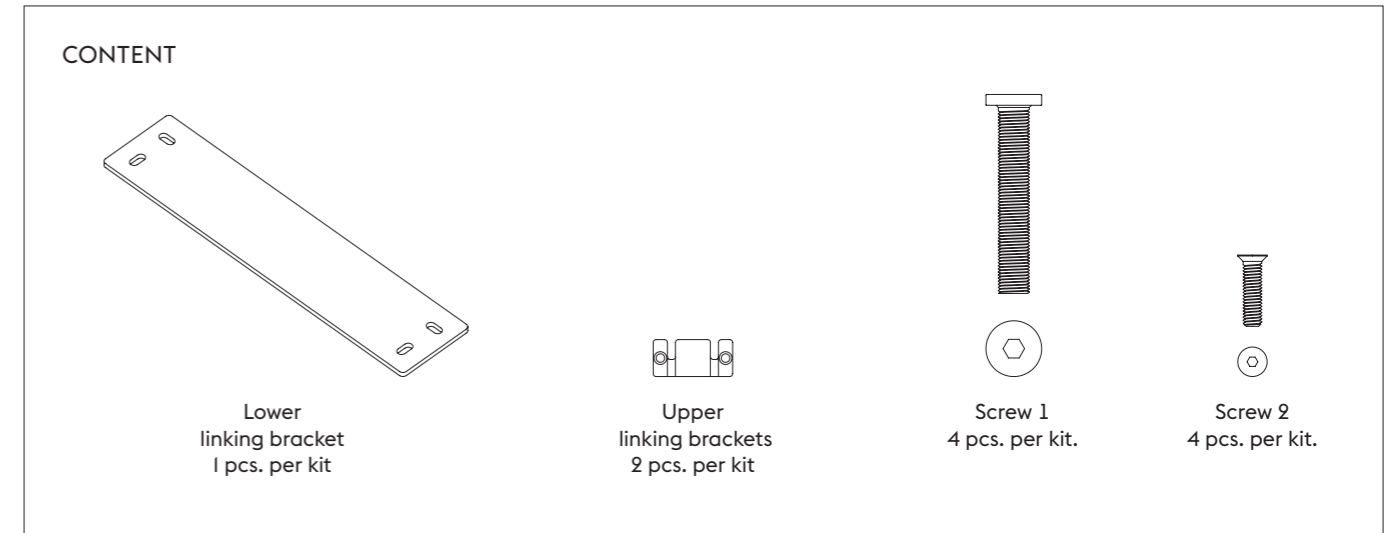

Use screw 1 x 2 to attach the lower linking bracket as illustrated to one fully assembled section.

NOTE — When assembly a corner configuration, the Lower Linking bracket must always be mounted on the adjacent configuration.

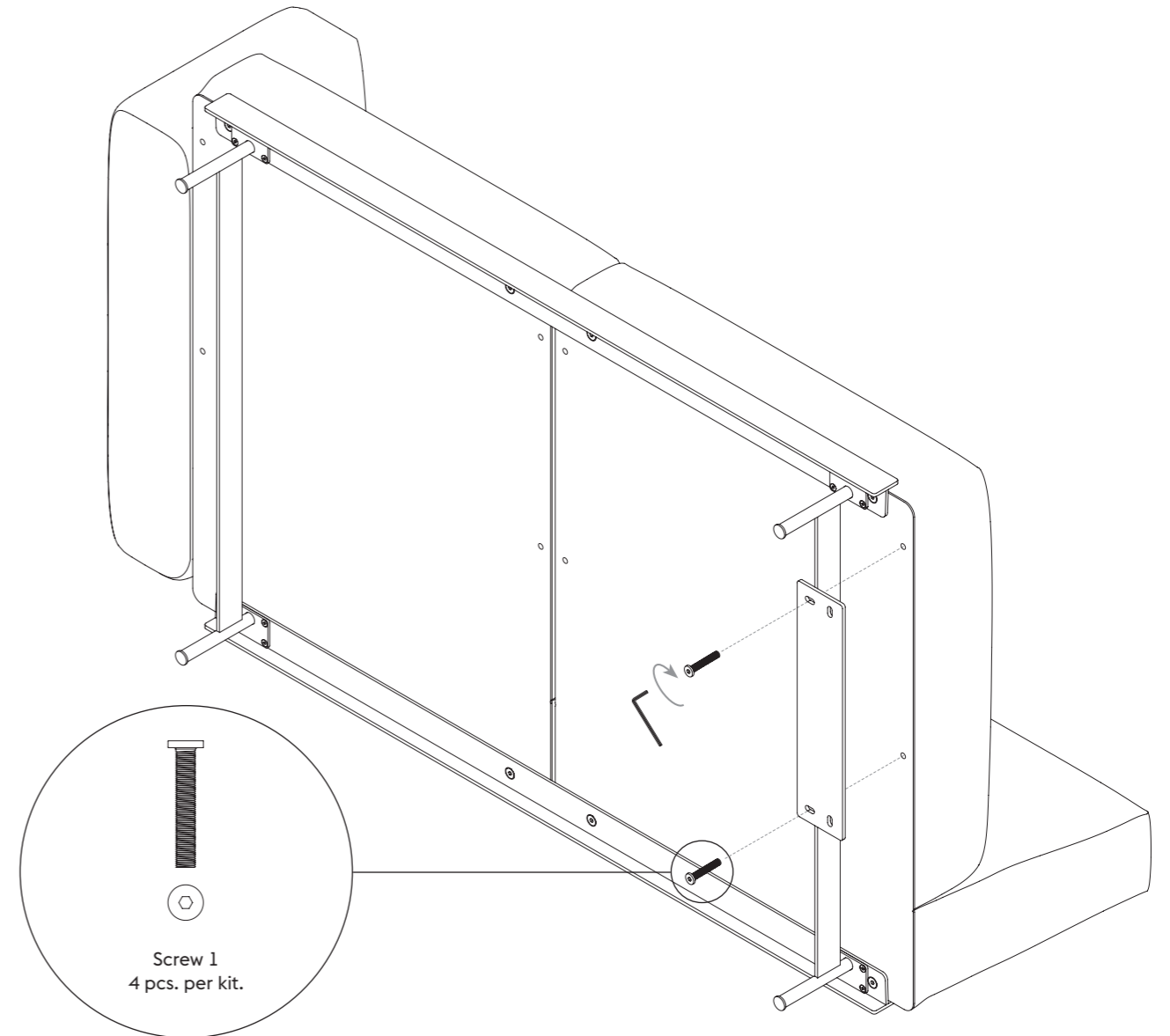

10 UPPER LINKING BRACKETS
ON CORNER CONFIGURATION

With screw 2, attach the upper linking brackets as shown. Make sure to face both brackets upwards.

NOTE — When assembling a corner configuration, the Upper Linking brackets on the adjacent configurations must always be mounted facing upwards.

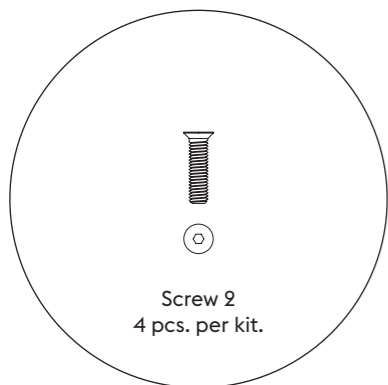
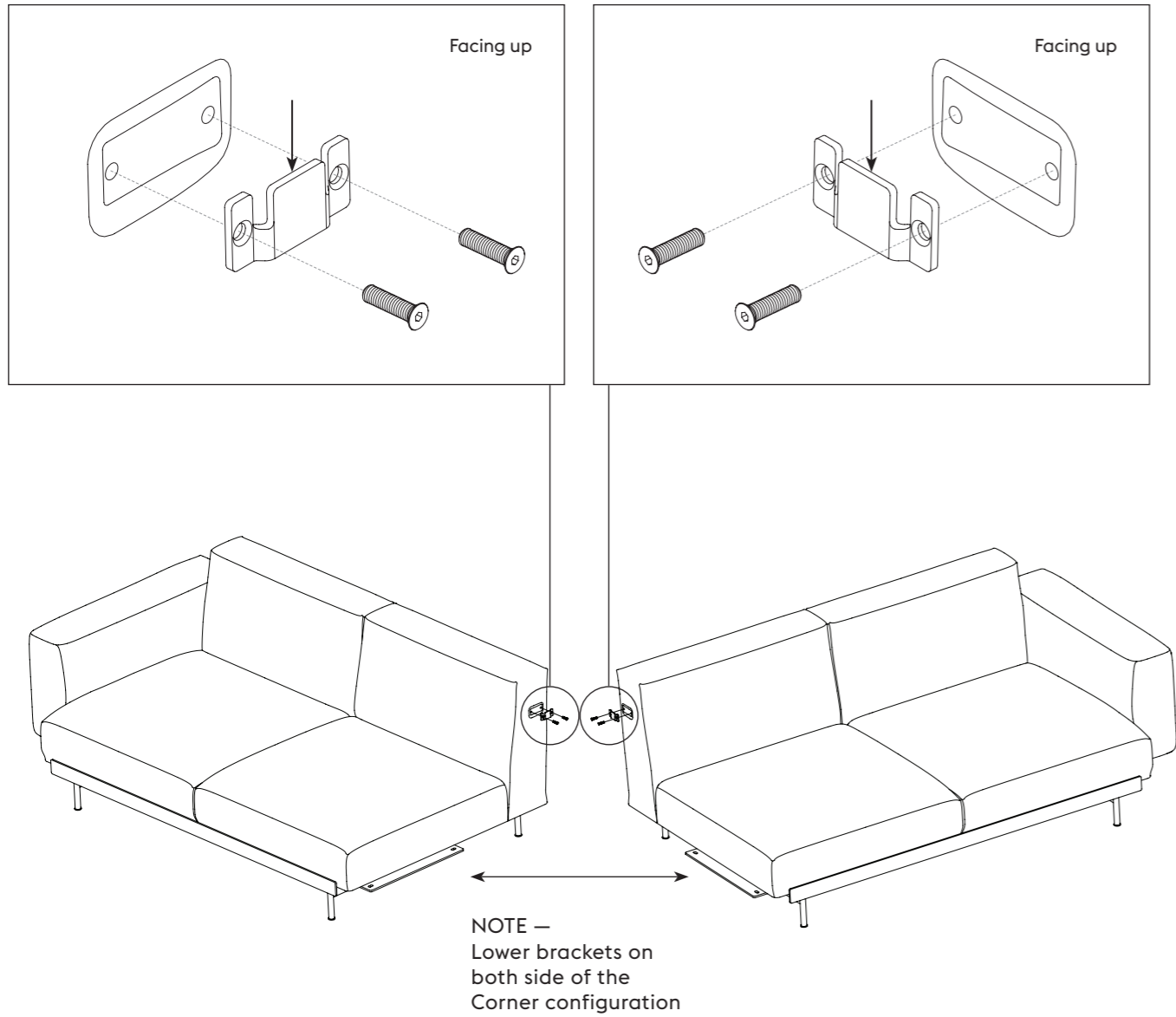

11 With screw 2, attach the upper linking brackets as shown. Make sure to have both sides facing down.

NOTE — When assembling a corner configuration, the Upper Linking brackets on both sides of the Corner configuration must always be mounted facing downwards.

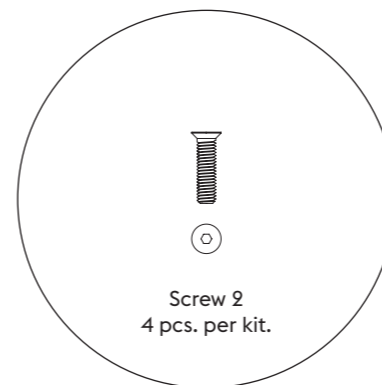
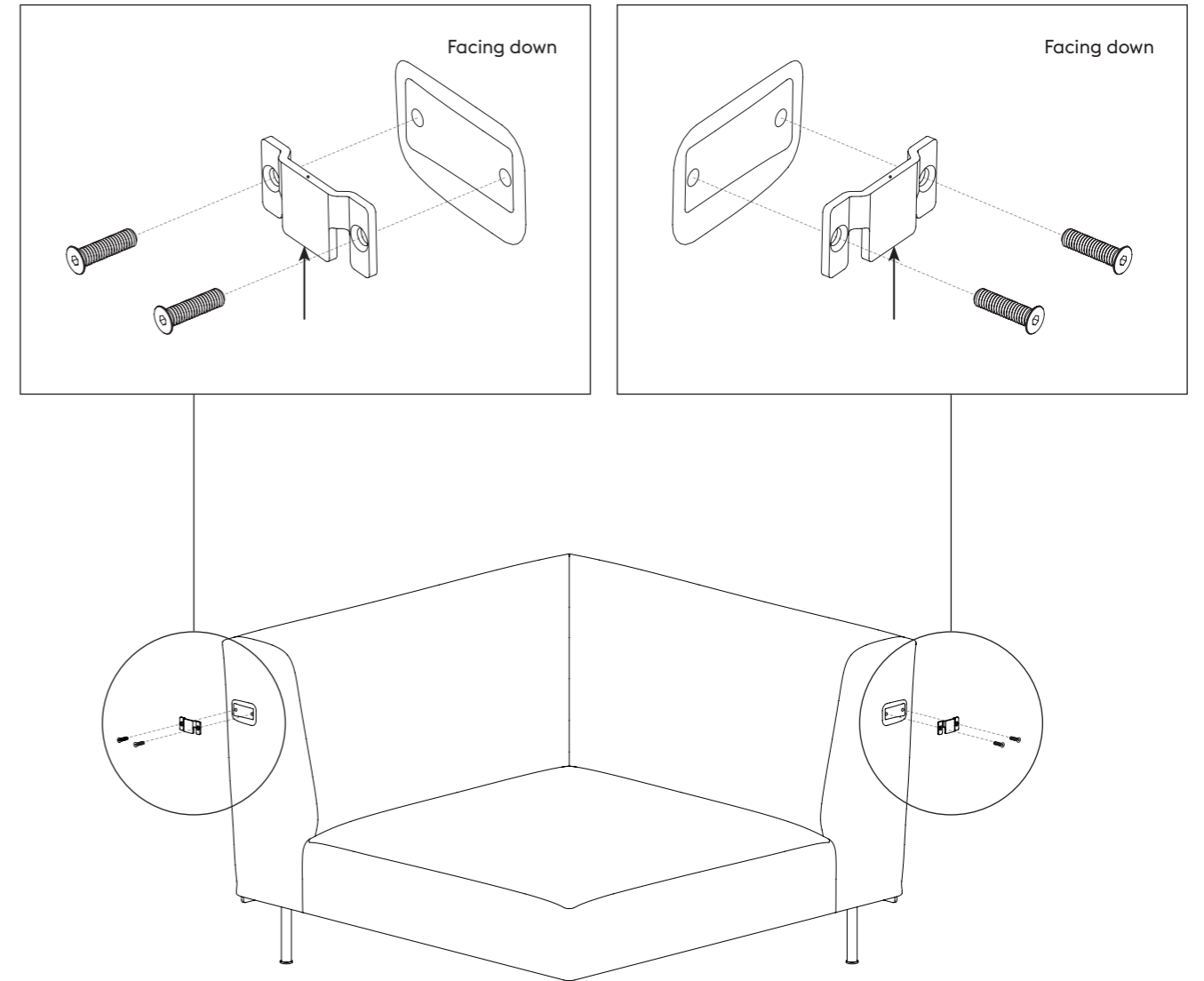

12 CORNER CONFIGURATION
TO CORNER CONFIGURATION

Link the upper brackets as shown, and secure the lower linking brackets with the remaining screws 1 x 4 underneath.

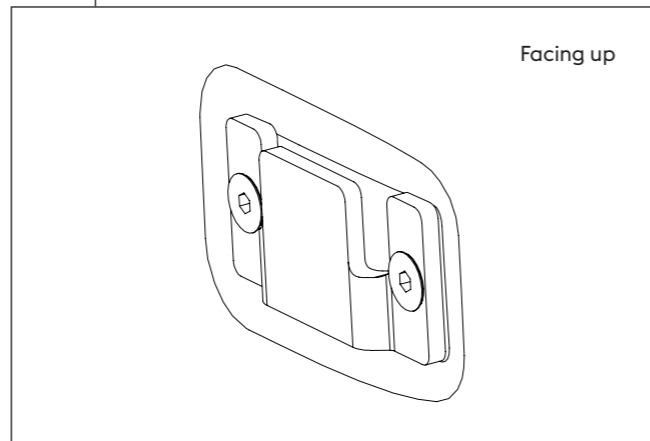
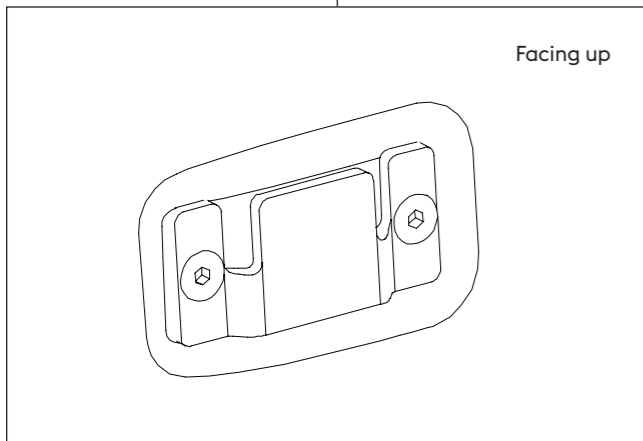
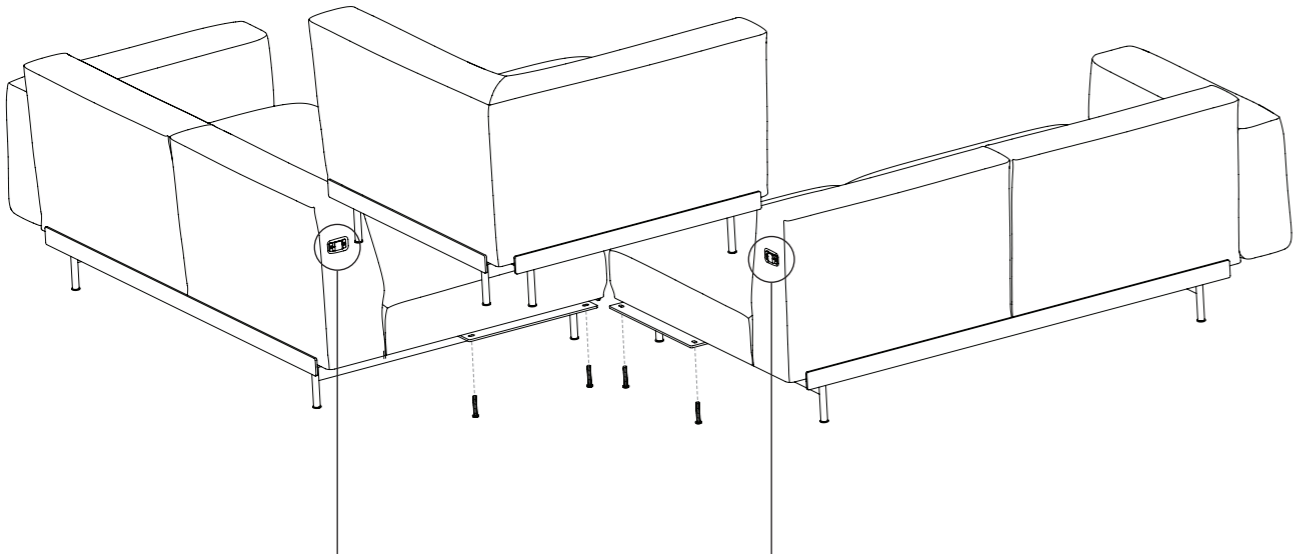
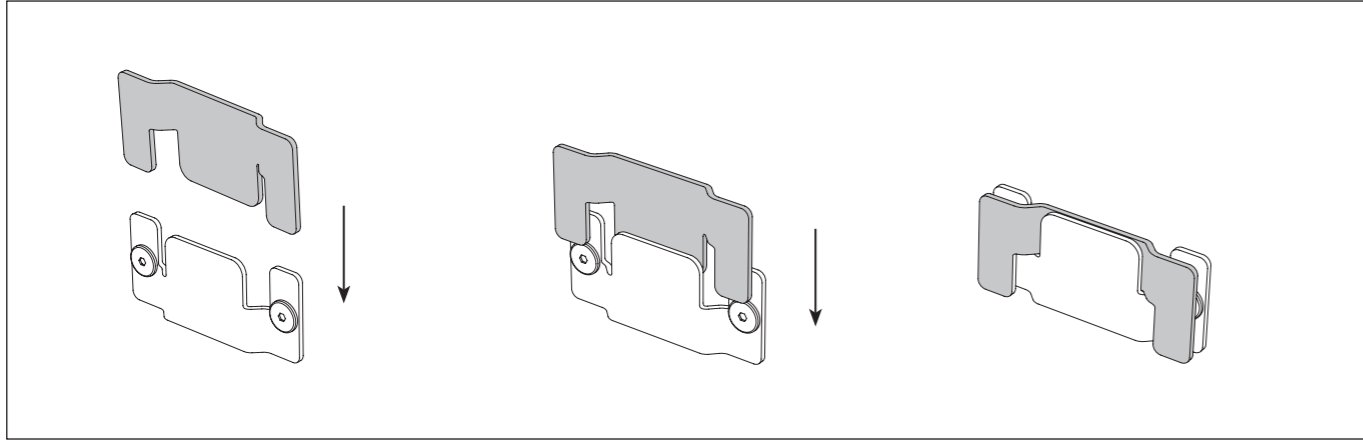

CLEANING — RENGØRING — SÄUBERN — NETTOYAGE — LIMPIEZA

- EN To remove stains from a textile-upholstered sofa, use foam from a mild mixture of water and detergent.
- DK Brug skummet fra en mild blanding af vand og opvaskemiddel til at fjerne pletter på en tekstil polstret sofa.
- DE Zum Entfernen von Flecken auf gepolsterten Sofas verwenden Sie den Schaum aus einer Wasser-Spülmittel-Mischung.
- FR Pour retirer les taches du textile sur les canapés, utilisez de la mousse depuis un mélange d'eau douce et du détergent.
- ES Para eliminar las manchas del tapizado textil de los sofás, utilice una solución de agua jabonosa neutra.